

Oct. 8, 1946.

W. E. WINN ET AL  
METHOD OF LOGGING WELLS

2,408,965

Filed Aug. 22, 1941

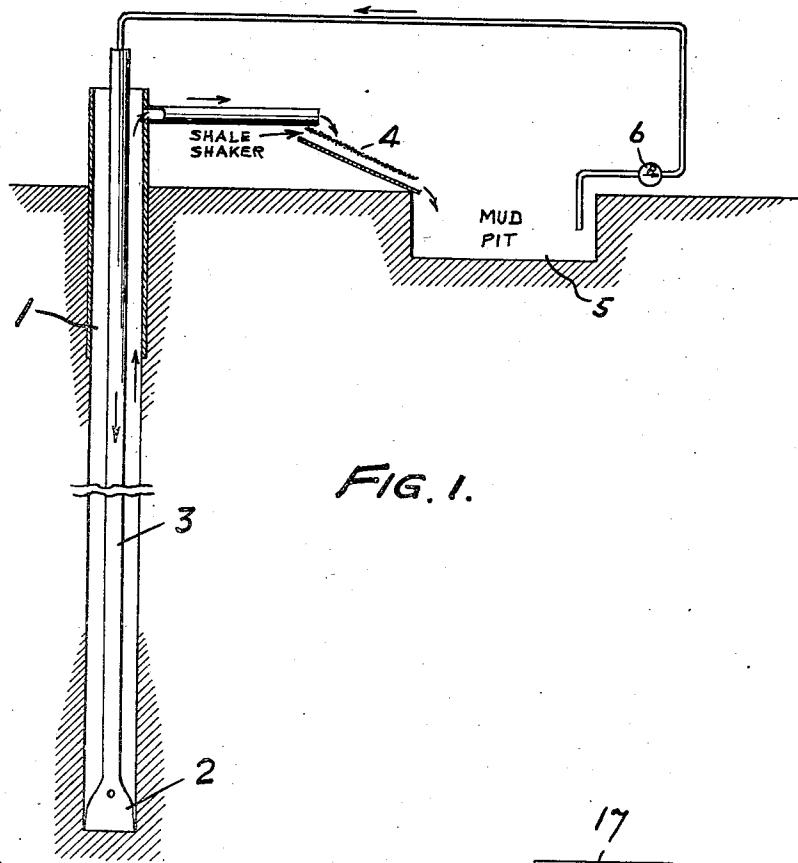

FIG. 1.

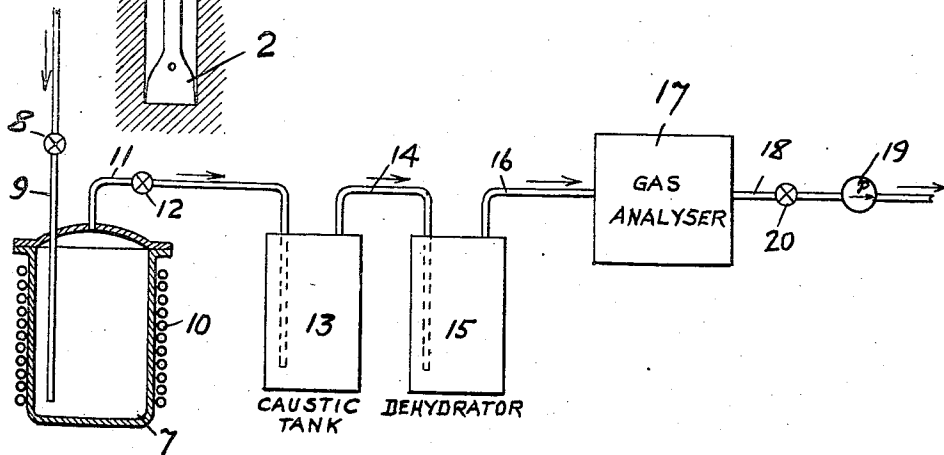

FIG. 2.

WITNESS:

*R. P. Pitschel*

INVENTORS.

*William E. Winn &  
Patrick F. Dougherty*  
Russo and Harding  
ATTORNEYS.

# UNITED STATES PATENT OFFICE

2,408,965

## METHOD OF LOGGING WELLS

William E. Winn, Dallas, Tex., and Patrick F. Dougherty, Chester, Pa., assignors to Sun Oil Company, Philadelphia, Pa., a corporation of New Jersey

Application August 22, 1941, Serial No. 407,956

2 Claims. (Cl. 23-232)

1

2

The present invention relates to a method of logging wells and is particularly directed to a method of detecting the presence of hydrocarbons in the formations traversed by a bore hole.

In drilling oil and gas wells, and other types of bore holes, it has long been recognized that the most reliable information concerning the nature of the formations traversed by the bore hole and the character of their fluid contents can be obtained from cores cut from the formations. However, the cutting of cores, either by full size bit or a wire line core barrel, is such a costly and time consuming process that it is a very rare practice to core a well throughout its entire depth. Instead, it is customarily the practice only to core when, in the opinion of the driller, useful information will be obtained by coring. Since the driller must rely on the action of the bit and other indications to tell him when to core, an error in judgment on his part will result in either the failure to core when he should or in the taking of unnecessary cores, resulting either in failure to obtain information which will be of certain value later on in proper development of the well being drilled, or unnecessary delay and expense.

Since it has proven impractical to core a bore hole throughout its depth, various methods for supplementing the information obtained by such coring as is done have been suggested and used. The most common of these methods are the running of electrical surveys during or after the completion of drilling and the taking of side wall cores based on the results of the electrical survey. These side wall cores are at times used in place of cores taken during the drilling, or they may be taken after drilling is completed when an electrical survey indicates that the driller failed to core when he should have done so. It has also been suggested that the mud, or drilling fluid, be analyzed during drilling in order to give an indication of the nature of the formation being traversed by the drill.

It is an object of the present invention to provide a method of logging wells, during drilling, which will supplement information obtained by coring and which is substantially as reliable as the information obtained by coring. A further object is to provide a method of logging wells which will indicate to the driller when it is desirable to core. Other objects will be apparent as the description progresses.

Briefly stated, our invention is based on the fact that the cuttings produced by the drill bit, and which are carried to the surface by the drilling fluid, are actually minute samples of the for-

mation traversed by the drill and may, therefore, be considered as very minute cores. Specifically, our invention is directed to an improved method of analyzing such cuttings in order that it will be necessary to cut cores only when detailed information is desired.

For a better understanding of the present invention, references should be made to the accompanying drawing, in which Fig. 1 is a diagrammatic representation of a well being drilled and Fig. 2 of which is a diagrammatic representation of apparatus suitable for practicing our invention.

In the drawing, 1 represents a well being drilled by bit 2. Drilling fluid is circulated down the drill pipe 3 and passes out through eyes in the bit 2, picks up cuttings formed by the action of the bit and rises to the surface in the annular space between the walls of the bore hole 1 and the drill pipe 3, carrying the cuttings suspended in it. At the surface the drilling fluid passes over the shale shaker 4, the cuttings being retained on the shaker while the drilling fluid passes therethrough and flows to a mud pit 5 from which it is picked up by mud pump 6 and recirculated through the drill pipe 3.

Samples of cuttings retained on the shale shaker 4 are, at regular intervals, removed therefrom and placed in a container 7. If desired, the cuttings may be washed in order to remove any adhering drilling fluid. The container 7 is then taken to a laboratory and the atmospheric gases therein are removed by flushing the container at atmospheric pressure with an inert gas, such as carbon dioxide. After the atmospheric gases have been removed from container 7, which may either be a bomb or a light weight container adapted to be placed in a bomb, gaseous carbon dioxide is admitted into the container under a superatmospheric pressure by opening valve 8 in line 9. The outlet line 11 from the container is closed by maintaining valve 12 therein, closed. The cuttings in container 7 are maintained under a superatmospheric pressure for a sufficient length of time to permit the carbon dioxide to enter the pores of the cuttings. Heat may also be applied to the cuttings in container 7 by means of heating coil 10. After the carbon dioxide has thoroughly permeated the cuttings, the pressure is released from the bomb 7 by opening valve 12 in line 11 to remove the carbon dioxide together with any gaseous or light liquid hydrocarbons stripped from the cuttings. The carbon dioxide with the hydrocarbons admixed therewith flows through line 11 to a caustic washing tank 13 and is bubbled through a solution of sodium hydroxide or other

3

suitable alkali to remove the carbon dioxide from the mixture. In order to insure complete removal of the carbon dioxide from the cuttings from bomb 7 we prefer to maintain valve 8 partly open while the carbon dioxide is being removed through line 11 in order to admit additional quantities of the carbon dioxide to the bomb 7 and thus fully flush from the bomb the carbon dioxide containing the hydrocarbons stripped from the cuttings. However, it is to be understood that if desired valve 8 may be closed during the removal of carbon dioxide from the bomb 7 and the removal of the carbon dioxide together with the light hydrocarbons may be effected by simple pressure reduction on opening valve 12 or by placing a vacuum on line 11. From the caustic washing tank 13 hydrocarbons which were stripped from the cuttings flow through line 14 to a dehydrator 15 where they pass through a suitable dehydrating agent, for instance, calcium chloride. The dried hydrocarbons then flow through line 16 to suitable analyzing equipment indicated diagrammatically at 17, wherein they are subjected to analysis to determine the quantity and identity of hydrocarbons present. Any gases present after analysis may be removed from the analyzing equipment through line 18 by vacuum pump 19. The valve 20 in line 18 is regulated to maintain desired pressure or vacuum on the equipment.

Carbon dioxide is used as a stripping agent for removing hydrocarbons from the cuttings due to the fact that we have found that it is especially effective when used in the manner described above. Although the reasons for its particular effectiveness as compared to other gases is not certain, it is thought that this may be due to its unusually high solubility in both water and hydrocarbons and to its relatively high adsorbability on clay or sand particles. In addition, carbon dioxide has the advantage of being readily removable from hydrocarbons admixed therewith. Further, if it is desired to analyze the removed hydrocarbons without first separating the stripping agent therefrom as by the well known combustion analysis, carbon dioxide is particularly satisfactory since it will not undergo combustion to liberate heat interfering with the analysis. Again, if it is desired to use known spectral methods of analysis such as by the mass spectrograph or infrared analysis, carbon dioxide is particularly suitable since it will not interfere with such analysis so that it need not be first removed from the hydrocarbons.

It should also be noted that in operating in accordance with the present invention we have discovered that the hydrocarbon content of the cuttings from a particular formation, as determined in the manner heretofore described, is a true representation of the hydrocarbon content of the formation from which the cuttings were obtained, and there is little or no penetration into the cuttings of hydrocarbons which may find their way into the drilling fluid from some source other than the particular formation being drilled at the time the cuttings are formed. Thus, in drilling one well in which both the present method of cuttings analysis and also a conventional method of mud analysis was used, the drilling fluid became contaminated with a large amount of gaseous hydrocarbons from an extraneous source, with the result that the conventional mud analysis showed the presence of large amounts of hydrocarbons throughout the entire course of drilling. However, it was found that analysis of the cuttings, in the manner specified herein, gave

4

a true picture of the amount and character of hydrocarbons present in the formations from which they were produced, there having been no apparent penetration of the hydrocarbons contaminating the drilling fluid into the pores of the cuttings produced by the drill. We believe that penetration of the pores of the cuttings by hydrocarbons present in the drilling fluid is prevented by the fact that each particle of cuttings is immediately coated, as soon as it is formed, with drilling fluid, the colloidal content of which prevents penetration of the cuttings by the fluids (hydrocarbons or others) present in the drilling fluid.

In logging by our method we have found that ordinarily hydrocarbon gases from oil bearing formations will be encountered in formations a substantial distance above the formations from which they were derived, and their detection in the cuttings is therefore an indication that the drill is approaching a gas or oil bearing formation. The character of the gases removed from the cuttings and detected by our method is an indication of the character of the fluid contents of the formations being approached by the drill. Frequently the presence of an oil bearing formation can be detected several hundred feet before the drill reaches it. By careful analysis of the cuttings we are also able to tell whether a non-producing well is merely off structure or in an entirely dry area. We are also able to tell from the type of hydrocarbons detected in the cuttings whether a drilling well is near the edge or near the top of a producing structure. We are also able to obtain valuable information as to the commercial possibilities of the formations drilled through.

It is well known, in the art of drilling wells, that in determining the depth at which any material from the formations traversed by the drill entered the mud stream, allowance must be made for the time necessary for the drilling mud to travel from the drill to the surface, and the distance that the drill has advanced during the interval that a particular portion of the mud fluid was travelling to the surface must be subtracted from the depth at which the drill is operating when this portion of the mud fluid reaches the surface, in order to accurately determine the depth at which the particular portion of the mud fluid under consideration passed the drill. However, various methods of determining and making allowance for this lag in the returns of mud from the drill are well known and, since they form no part of the present invention, they are not herein described.

We claim:

1. The method of logging oil wells which comprises treating the drilling mud delivered from the well to separate therefrom the drilling fluid and the cuttings, intimately mixing said cuttings with gaseous carbon dioxide at a superatmospheric pressure effective to cause the carbon dioxide to permeate said cuttings, lowering the pressure on the cuttings to remove therefrom carbon dioxide and any hydrocarbons admixed therewith and subjecting the mixture to a treatment including an analysis to determine the amount of hydrocarbons, thereby ascertaining the content of such hydrocarbons in the formation from which the cuttings were obtained.
2. The method defined in claim 1 wherein the analysis includes a determination of the identity of the hydrocarbons.

WILLIAM E. WINN.  
PATRICK F. DOUGHERTY.