

(12) INTERNATIONAL APPLICATION PUBLISHED UNDER THE PATENT COOPERATION TREATY (PCT)

(19) World Intellectual Property
Organization

International Bureau

(43) International Publication Date
20 April 2023 (20.04.2023)



(10) International Publication Number
WO 2023/060476 A1

(51) International Patent Classification:

A24F 40/40 (2020.01)

(21) International Application Number:

PCT/CN2021/123535

(22) International Filing Date:

13 October 2021 (13.10.2021)

(25) Filing Language:

English

(26) Publication Language:

English

(71) Applicant: PHILIP MORRIS PRODUCTS S.A.

[CH/CH]; Quai Jeanrenaud 3, 2000 Neuchâtel (CH).

(72) Inventors: LIU, Liu; Section 37, Zhongkai Development

Zone for New and High-Level Tech Industries, Huizhou, Guangdong 516006 (CN). YIM, Jun Wei; Quai Jeanrenaud 3, 2000 Neuchâtel (CH).

(74) Agent: KING & WOOD MALLESONS; 20th Floor,

East Tower, World Financial Centre, No. 1 Dongsanhuan Zhonglu, Chaoyang District, Beijing 100020 (CN).

(81) Designated States (unless otherwise indicated, for every

kind of national protection available): AE, AG, AL, AM, AO, AT, AU, AZ, BA, BB, BG, BH, BN, BR, BW, BY, BZ, CA, CH, CL, CN, CO, CR, CU, CZ, DE, DJ, DK, DM, DO, DZ, EC, EE, EG, ES, FI, GB, GD, GE, GH, GM, GT, HN, HR, HU, ID, IL, IN, IR, IS, IT, JO, JP, KE, KG, KH, KN,

KP, KR, KW, KZ, LA, LC, LK, LR, LS, LU, LY, MA, MD, ME, MG, MK, MN, MW, MX, MY, MZ, NA, NG, NI, NO, NZ, OM, PA, PE, PG, PH, PL, PT, QA, RO, RS, RU, RW, SA, SC, SD, SE, SG, SK, SL, ST, SV, SY, TH, TJ, TM, TN, TR, TT, TZ, UA, UG, US, UZ, VC, VN, WS, ZA, ZM, ZW.

(84) Designated States (unless otherwise indicated, for every kind of regional protection available): ARIPO (BW, GH, GM, KE, LR, LS, MW, MZ, NA, RW, SD, SL, ST, SZ, TZ, UG, ZM, ZW), Eurasian (AM, AZ, BY, KG, KZ, RU, TJ, TM), European (AL, AT, BE, BG, CH, CY, CZ, DE, DK, EE, ES, FI, FR, GB, GR, HR, HU, IE, IS, IT, LT, LU, LV, MC, MK, MT, NL, NO, PL, PT, RO, RS, SE, SI, SK, SM, TR), OAPI (BF, BJ, CF, CG, CI, CM, GA, GN, GQ, GW, KM, ML, MR, NE, SN, TD, TG).

Published:

— with international search report (Art. 21(3))

(54) Title: AEROSOL-GENERATING DEVICE WITH ARTICLE RETENTION

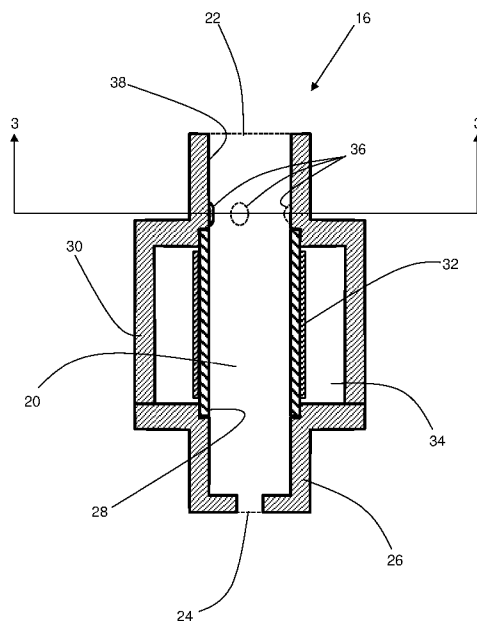

Figure 2

(57) Abstract: There is provided an aerosol-generating device (10) comprising a cavity (20) for receiving an aerosol-generating article (100), the cavity (20) having a first end and a second end opposite the first end. The aerosol-generating device (10) also comprises an opening (22) at a first end of the cavity (20) for inserting an aerosol-generating article into the cavity (20), and at least one heating element (32). The aerosol-generating device (10) also comprises a plurality of projections (36) extending from an internal surface (38) of the cavity (20), wherein every projection (36) is positioned closer to the first end of the cavity (20) than the second end of the cavity (20).



WO 2023/060476 A1

AEROSOL-GENERATING DEVICE WITH ARTICLE RETENTION

The present disclosure relates to an aerosol-generating device comprising a cavity and a plurality of projections extending from an internal surface of the cavity. The present invention also relates to an aerosol-generating system comprising the aerosol-generating device and an aerosol-generating article.

Aerosol generating devices which heat an aerosol-forming substrate to produce an aerosol without burning the aerosol-forming substrate are known in the art. The aerosol-forming substrate is typically provided within an aerosol-generating article, together with other components such as one or more filter segments. The aerosol-generating article may have a rod shape for insertion of the aerosol-generating article into a cavity of the aerosol-generating device. A heating element is typically arranged to heat the aerosol-forming substrate once the aerosol-generating article is inserted into the cavity of the aerosol-generating device. The heating element may comprise an internal heating element that extends into the cavity and is received in the aerosol-generating article. The heating element may comprise an external heating element arranged to extend around the outside of the aerosol-generating.

To optimise the heating of the aerosol-forming substrate it is desirable to reduce or substantially prevent movement of the aerosol-generating article within the cavity during use of the aerosol-generating device. This is typically achieved by an interference fit between the aerosol-generating article and the cavity, and an interference fit between the aerosol-generating article and the heating element in examples comprising an internal heating element. However, it is also desirable to configure the aerosol-generating device to avoid requiring a user to exert a large force to insert the aerosol-generating article into and remove the aerosol-generating article from the cavity. It can be difficult to balance these two opposing requirements since one or more physical properties of the aerosol-generating article may change during use as the aerosol-generating article is heated and moisture is released from the aerosol-forming substrate. It can also be particularly difficult to balance the two opposing requirements in devices comprising only an external heating element, which may not provide a sufficient interference fit compared to devices comprising an internal heating element.

It would be desirable to provide an aerosol-generating device that mitigates or overcomes these issues with known aerosol-generating devices.

According to an example of the present disclosure there is provided an aerosol-generating device comprising a cavity for receiving an aerosol-generating article, at least one heating element, and a plurality of projections extending from an internal surface of the cavity.

Advantageously, the plurality of projections engage an aerosol-generating article when the aerosol-generating article is inserted into the cavity. Advantageously, the engagement between the plurality of projections and the aerosol-generating article facilitates retention of the aerosol-generating article within the cavity during use of the aerosol-generating device.

Advantageously, the plurality of projections may provide more precise control of an interference fit between an aerosol-generating article and the aerosol-generating device. For example, the interference fit may be more precisely controlled by varying at least one of a size, shape, number and position of the projections.

5 As used herein, the term “aerosol-generating article” refers to an article comprising an aerosol-forming substrate that, when heated in the aerosol-generating device, releases volatile compounds that can form an aerosol. An aerosol-generating article is separate from and configured for combination with the aerosol-generating device for heating the aerosol-generating article.

10 According to another example of the present disclosure there is provided an aerosol-generating device comprising a cavity for receiving an aerosol-generating article, the cavity having a first end and a second end opposite the first end. The aerosol-generating device also comprises an opening at a first end of the cavity for inserting an aerosol-generating article into the cavity, and at least one heating element. The aerosol-generating device also comprises a
15 plurality of projections extending from an internal surface of the cavity, wherein every projection is positioned closer to the first end of the cavity than the second end of the cavity.

Advantageously, positioning the projections closer to the first end than the second end provides engagement between the projections and an aerosol-generating article when only a portion of the aerosol-generating article has been inserted into the cavity. Advantageously, this
20 may facilitate insertion of the aerosol-generating article into a correct position within the cavity.

Each projection may have a cross-sectional shape that is elliptical, oval, or circular. Advantageously, each of these cross-sectional shapes may provide each projection with a rounded surface. Advantageously, a rounded surface may facilitate sliding of an aerosol-generating article across the projections when the aerosol-generating article is inserted into and
25 removed from the cavity. Advantageously, this may reduce a force required to insert the aerosol-generating article into and remove the aerosol-generating article from the cavity. This is particularly advantageous in examples in which the aerosol-generating article comprises a paper wrapper, which may be relatively fragile after use due to absorption of moisture by the paper wrapper from an aerosol-forming substrate.

30 Preferably, each projection has a circular cross-sectional shape.

Preferably, each projection has a convex shape. Each projection may have a hemispherical shape. Each projection may have a truncated cone shape.

Preferably, each projection has a truncated hemispherical shape. Advantageously, the hemispherical portion of the shape provides each projection with a rounded portion, which
35 facilitates insertion of an aerosol-generating article into the cavity and removal of the aerosol-generating article from the cavity, as described above. Advantageously, the truncated portion of the shape increases an area of contact between each projection and an aerosol-generating article when the aerosol-generating article is received within the cavity. Advantageously, the

increased area of contact facilitates retention of the aerosol-generating article within the cavity during use of the aerosol-generating device.

According to another example of the present disclosure there is provided an aerosol-generating device comprising a cavity for receiving an aerosol-generating article, at least one heating element, and a plurality of projections extending from an internal surface of the cavity, wherein each projection has a truncated hemispherical shape.

Advantageously, the hemispherical portion of the shape provides each projection with a rounded portion. Advantageously, a rounded portion may facilitate sliding of an aerosol-generating article across the projections when the aerosol-generating article is inserted into and removed from the cavity. Advantageously, this may reduce a force required to insert the aerosol-generating article into and remove the aerosol-generating article from the cavity. This is particularly advantageous in examples in which the aerosol-generating article comprises a paper wrapper, which may be relatively fragile after use due to absorption of moisture by the paper wrapper from an aerosol-forming substrate.

Advantageously, the truncated portion of the shape increases an area of contact between each projection and an aerosol-generating article when the aerosol-generating article is received within the cavity. Advantageously, the increased area of contact facilitates retention of the aerosol-generating article within the cavity during use of the aerosol-generating device.

Preferably, the cavity has a first end and a second end opposite the first end, wherein the aerosol-generating device further comprises an opening at a first end of the cavity for inserting an aerosol-generating article into the cavity. Preferably, every projection is positioned closer to the first end of the cavity than the second end of the cavity.

Advantageously, positioning the projections closer to the first end than the second end provides engagement between the projections and an aerosol-generating article when only a portion of the aerosol-generating article has been inserted into the cavity. Advantageously, this may facilitate insertion of the aerosol-generating article into a correct position within the cavity.

The following optional and preferred features may be combined with any of the examples of the present disclosure.

In examples in which the aerosol-generating device comprises an opening at a first end of the cavity, an aerosol-generating article may be inserted into the cavity through the opening. When an aerosol-generating article has been fully inserted into the cavity, part of the aerosol-generating article may protrude from the cavity via the opening. For example, a mouth end of the aerosol-generating article may protrude through the opening for engagement with a user's mouth during use. The opening may be an aerosol outlet through which aerosol may be drawn out of the cavity during use of the aerosol-generating device. For example, in examples in which a mouth end of an aerosol-generating article protrudes from the cavity via the opening, aerosol may exit the cavity through the mouth end of the aerosol-generating article.

Preferably, all of the projections are equidistantly spaced from the opening. Advantageously, this may facilitate simultaneous engagement of the projections with an aerosol-generating article when the aerosol-generating article is inserted into the cavity. Advantageously, this may help to guide the aerosol-generating article into a correct position within the cavity.

The aerosol-generating device may comprise an end face at a second end of the cavity, wherein the second end is opposite the first end, and wherein the end face is arranged to abut an aerosol-generating article when the aerosol-generating article is fully inserted into the cavity. Advantageously, the end face facilitates insertion of an aerosol-generating article into the correct position within the cavity. In particular, a user may push an aerosol-generating article into the cavity until the aerosol-generating article engages the end face.

The aerosol-generating device may comprise a stopper positioned within the cavity and arranged to abut an aerosol-generating article when the aerosol-generating article is fully inserted into the cavity. Advantageously, the stopper facilitates insertion of an aerosol-generating article into the correct position within the cavity. In particular, a user may push an aerosol-generating article into the cavity until the aerosol-generating article engages the stopper. In examples comprising a stopper, the stopper may define the second end of the cavity. The stopper may comprise a pin, a bar, a rod, a pole, a shaft, a beam, a rail, a strut, a spoke, a stem, or a crossbar.

Preferably, the cavity defines an air inlet at the second end of the cavity, wherein the air inlet is in fluid communication with the opening via the cavity. During use, air may flow through the cavity from the air inlet to the opening. When an aerosol-generating article is inserted into the cavity, air may flow through the aerosol-generating article from the air inlet. In examples in which the aerosol-generating device comprise an end face at the second end of the cavity, the air inlet may extend through the end face. The end face may have an annular shape defining the air inlet at the centre of the end face.

The cavity may comprise a length extending between the first end and the second end. Preferably, a distance between the first end and each projection is less than one third of the length of the cavity. Preferably, the distance is the distance between the first end and an edge of the projection furthest from the first end. In other words, preferably, each projection is contained entirely within the first third of the length of the cavity from the first end.

Advantageously, positioning the protrusions within the first third of the length of the cavity provides engagement between the projections and an aerosol-generating article when only a portion of the aerosol-generating article has been inserted into the cavity. Advantageously, this may facilitate insertion of the aerosol-generating article into a correct position within the cavity.

Preferably, each projection is fixed with respect to the internal surface of the cavity. Advantageously, providing fixed projections may simplify the aerosol-generating device

compared to known devices that may comprise one or more movable or removable parts for selectively engaging an aerosol-generating article received within the device. Advantageously, eliminating such movable or removable parts may eliminate a potential failure point of the aerosol-generating device and may reduce the cost of manufacturing the aerosol-generating device. Advantageously, eliminating such moveable or removable parts may simplify operation of the aerosol-generating device for a user.

Preferably, the projections are equidistantly spaced about a circumference of the internal surface of the cavity. Advantageously, spacing the projections equally around the circumference helps to guide an aerosol-generating article into the correct position within the cavity when the aerosol-generating article is inserted into the cavity.

Preferably, each projection has a maximum cross-sectional diameter of between about 0.8 millimetres and about 2 millimetres, preferably between about 1.0 millimetre and 1.5 millimetres, preferably between about 1.2 millimetres and about 1.3 millimetres. Advantageously, projections having a maximum cross-sectional diameter within these ranges may facilitate sufficient retention of an aerosol-generating article within the cavity without providing an undesirably large resistance to insertion of the aerosol-generating article into the cavity.

Preferably, each projection has a height extending in a direction perpendicular to the internal surface of the cavity, wherein the maximum height of each projection is between about 0.05 millimetres and about 0.5 millimetres, preferably between about 0.07 millimetres and about 0.3 millimetres, preferably between about 0.08 millimetres and about 0.2 millimetres, preferably between about 0.095 millimetres and about 0.1 millimetres. Advantageously, projections having a maximum height within these ranges may facilitate sufficient retention of an aerosol-generating article within the cavity without providing an undesirably large resistance to insertion of the aerosol-generating article into the cavity.

Preferably, the cavity has a circular cross-sectional shape, wherein the internal surface of the cavity is a circumferential internal surface of the cavity.

Each projection may have a first end connected to the internal surface of the cavity and a second end opposite the first end. The circular cross-sectional shape of the cavity may have a minimum diameter defined by the second ends of the projections. Preferably, the minimum diameter is between about 7.0 millimetres and about 7.6 millimetres, more preferably between about 7.1 millimetres and about 7.5 millimetres, more preferably between about 7.2 millimetres and about 7.4 millimetres.

The plurality of projections may comprise any suitable number of projections. Preferably, the plurality of projections comprises a total of at least three projections. The plurality of projections may comprise a total of eight projections or fewer. The plurality of projections may comprise a total of seven projections or fewer. The plurality of projections may comprise a total of six projections or fewer. Preferably, the plurality of projections comprises a total of five

projections. Advantageously, a total of five projections may facilitate sufficient retention of an aerosol-generating article within the cavity without providing an undesirably large resistance to insertion of the aerosol-generating article into the cavity.

5 The at least one heating element may be a single heating element. The at least one heating element may comprise a plurality of heating elements.

10 The at least one heating element may comprise an internal heating element extending into the cavity and arranged to be received within a portion of an aerosol-generating article when the aerosol-generating article is inserted into the cavity. The internal heating element may extend into the cavity from the second end of the cavity. In examples in which the aerosol-generating device comprises an end face at the second end of the cavity, the internal heating element may extend into the cavity from the end face. The internal heating element may be an electrically resistive heating element.

The at least one heating element may comprise an external heating element extending around at least a portion of an external surface of the cavity.

15 The external heating element may comprise at least one inductor coil. The at least one inductor coil may be wound around at least a portion of the external surface of the cavity. The at least one inductor coil may be arranged to inductively heat one or more susceptor elements during use of the aerosol-generating device. The one or more susceptor elements may form part of an aerosol-generating article. The one or more susceptor elements may form part of the aerosol-generating device.

20 The aerosol-generating device may comprise a tubular susceptor element defining at least a portion of the cavity. During use, at least a portion of an aerosol-generating article inserted into the cavity may be received within the tubular susceptor element. Preferably, the at least one inductor coil extend around an external surface of the tubular susceptor element.

25 The aerosol-generating device may comprise one or more susceptor elements extending into the cavity and arranged to be received within a portion of an aerosol-generating article when the aerosol-generating article is inserted into the cavity. The one or more susceptor elements may extend into the cavity from the second end of the cavity. In examples in which the aerosol-generating device comprises an end face at the second end of the cavity, the one or more susceptor elements may extend into the cavity from the end face.

30 The external heating element may be an electrically resistive heating element.

In examples in which the at least one heating element comprises an electrically resistive heating element, the electrically resistive heating element comprises an electrically resistive material. Suitable electrically resistive materials include but are not limited to: semiconductors such as doped ceramics, electrically "conductive" ceramics (such as, for example, molybdenum disilicide), carbon, graphite, metals, metal alloys and composite materials made of a ceramic material and a metallic material. Such composite materials may comprise doped or undoped ceramics. Examples of suitable doped ceramics include doped silicon carbides. Examples of

suitable metals include titanium, zirconium, tantalum and metals from the platinum group. Examples of suitable metal alloys include stainless steel, nickel-, cobalt-, chromium-, aluminium-titanium- zirconium-, hafnium-, niobium-, molybdenum-, tantalum-, tungsten-, tin-, gallium-, manganese-, gold- and iron-containing alloys, and super-alloys based on nickel, iron, cobalt, stainless steel, Timetal™, Kanthal™ and other iron-chromium-aluminium alloys, and iron-manganese-aluminium based alloys. In composite materials, the electrically resistive material may optionally be embedded in, encapsulated or coated with an insulating material or vice-versa, depending on the kinetics of energy transfer and the external physicochemical properties required.

10 The electrically resistive heating element may be formed using a metal or metal alloy having a defined relationship between temperature and resistivity. Heating elements formed in this manner may be used to both heat and monitor the temperature of the heating element during operation.

15 The electrically resistive heating element may be deposited in or on a rigid carrier material or substrate. The electrically resistive heating element may be deposited in or on a flexible carrier material or substrate. The electrically resistive heating element may be formed as a track on a suitable insulating material, such as ceramic or glass or polyimide film. The electrically resistive heating element may be sandwiched between two insulating materials.

20 In examples in which the heating element comprises an external electrically resistive heating element, the heating element may comprise a heat-resistant flexible polyimide film having electrically resistive heating tracks formed on the film. The electrically resistive heating tracks may be formed in a serpentine pattern on the film. The electrically resistive heating tracks may comprise any of the suitable electrically resistive materials described herein.

25 In examples in which the heating element comprise an external heating element, preferably the external heating element extends around only a central portion of the cavity to define a heating zone. The term "central portion" is used to refer to a portion of the cavity in between the first end and the second end. Preferably, the cavity comprises a downstream portion extending between the first end and the central portion, and an upstream portion extending between the central portion and the second end. As used herein, the terms
30 "upstream" and "downstream" refer to the direction of airflow through the cavity during use of the aerosol-generating device. During use, air flows from upstream to downstream. The first end of the cavity may be referred to as the "downstream end" and the second end of the cavity may be referred to as the "upstream end".

35 Preferably, the projections are positioned outside of the heating zone. Advantageously, positioning the projections outside of the heating zone may facilitate engagement of the projections with a portion of an aerosol-forming article that does not overlie an aerosol-forming substrate within the aerosol-forming article. Advantageously, this may facilitate engagement of

the projections with a more rigid portion of an aerosol-generating article, which may provide a more consistent and reliable retention of the aerosol-generating article within the cavity.

Preferably, the projections are positioned between the opening and the heating zone. The projections may be positioned immediately downstream of the heating zone.

5 The aerosol-generating device may comprise at least one housing portion at least partially defining the internal surface of the cavity. Preferably, the projections are integrally formed with the at least one housing portion. Advantageously, the integrally formed projections may simplify the manufacture of the aerosol-generating device.

10 The at least one housing portion may be a single housing portion defining the internal surface of the cavity.

The at least one housing portion may comprise a first heater casing comprising an air inlet and a second heater casing defining the opening, wherein the projections are provided on the second heater casing.

15 Preferably, at least one of the first and second heater casings may comprise a material that can be injection moulded.

At least one of the first and second heater casings may comprise a polymer. Polymers have been found to be particular suitable materials due to their elastic properties.

20 The first and second heater casings may comprise any suitable material or combination of materials. Examples of suitable materials include plastics or composite materials containing one or more materials, or thermoplastics that are suitable for food or pharmaceutical applications, for example polypropylene, polyetheretherketone (PEEK), polyphenylsulfone (PPSU) and polyethylene. Preferably, at least one of the first and second heater casing comprises PEEK or PPSU.

25 The aerosol-generating device may also comprise a heating chamber arranged between the first heater casing and the second heater casing, wherein the heating chamber, the first heater casing and the second heater casing together define the internal surface of the cavity. In examples comprising an external heating element, preferably the external heating element extends around the heating chamber. Preferably, the external heating element extends around the heating chamber only.

30 At least one of the first heater casing and the second heating casing may define a space extending around an external surface of the heating chamber. Advantageously, the space may reduce heat losses from the heating chamber and reduces heat transfer to an exterior of the aerosol-generating device. The spaced may be at least partially filled with an insulating material. The space may be at least partially filled with air. The space may be at least partially filled with
35 a microporous insulating material. The microporous insulating material may be inorganic. The microporous insulating material may be a ceramic. The microporous insulating material may comprise silica (SiO₂). The microporous insulating material may comprise pyrogenic silica. The

microporous insulating material may comprise other components like opacifiers and fibers. The opacifier may scatter infrared radiation and thereby reduce transmission of infrared radiation.

Preferably, the projections are positioned between the heating chamber and the opening. Preferably, the projections are positioned adjacent a downstream end of the heating chamber.

5 In other words, preferably the projections are positioned immediately downstream of the heating chamber.

The heating chamber may be made from any suitable material including, but not limited to, a ceramic or metal or metal alloy. An example of a suitable material is stainless steel.

10 Preferably, the aerosol-generating device comprises a power supply and a controller arranged to control a supply of power from the power supply to the at least one heating element.

The power supply may be any suitable power supply, for example a DC voltage source. In one embodiment, the power supply is a Lithium-ion battery. Alternatively, the power supply may be a Nickel-metal hydride battery, a Nickel cadmium battery, or a Lithium based battery, for example a Lithium-Cobalt, a Lithium-Iron-Phosphate or a Lithium-Polymer battery.

15 The controller may comprise a microprocessor. The microprocessor may be a programmable microprocessor, a microcontroller, or an application specific integrated chip (ASIC) or other electronic circuitry capable of providing control. The controller may comprise further electronic components. For example, in some embodiments, the controller may comprise any of: sensors, switches, display elements. Power may be supplied to the heater assembly
20 continuously following activation of the device or may be supplied intermittently, such as on a puff-by-puff basis. The power may be supplied to the heater assembly in the form of pulses of electrical current, for example, by means of pulse width modulation (PWM).

According to another example of the present disclosure there is provided an aerosol-generating system comprising an aerosol-generating device according to any of the examples
25 described herein, and an aerosol-generating article. The aerosol-generating article comprises a segment of aerosol-forming substrate and at least one further segment positioned downstream of the segment of aerosol-forming substrate. The aerosol-generating article also comprises an outer wrapper extending around the segment of aerosol-forming substrate and the at least one further segment.

30 Preferably, the projections are positioned to engage a portion of the outer wrapper extending around the at least one further segment when the aerosol-generating article is fully inserted into the cavity. Advantageously, the at least one further segment may be more rigid than the segment of aerosol-forming substrate. Advantageously, arranging the projections to engage a portion of the outer wrapper overlying a more rigid further segment may provide a
35 more consistent and reliable retention of the aerosol-generating article within the cavity.

The at least one further segment may comprise at least one hollow tube positioned downstream of the segment of aerosol-forming substrate. The hollow tube may be an acetate tube. The hollow tube may be a cardboard tube. Preferably, the projections are positioned to

engage a portion of the outer wrapper extending around the hollow tube when the aerosol-generating article is fully inserted into the cavity

The at least one further segment may comprise at least one filter segment positioned downstream of the at least one hollow tube. Preferably, the at least one filter segment comprises cellulose acetate fibres. The at least one filter segment may form a mouthpiece. The at least one filter segment may be positioned at a "mouth end" or "downstream end" of the aerosol-generating article.

The segment of aerosol-forming substrate may be positioned at an upstream end of the aerosol-generating article.

The aerosol-generating article may comprise an upstream segment positioned upstream of the segment of aerosol-forming substrate. The upstream segment may be positioned at an upstream end of the aerosol-generating article. The upstream segment may comprise a hollow tube. The hollow tube may be an acetate tube. The hollow tube may be a cardboard tube.

The outer wrapper may be a paper outer wrapper.

Preferably, the aerosol-forming substrate comprises tobacco.

The aerosol-forming substrate may be a solid aerosol-forming substrate. Alternatively, the aerosol-forming substrate may comprise both solid and liquid components. The aerosol-forming substrate may comprise a tobacco-containing material containing volatile tobacco flavour compounds which are released from the substrate upon heating. Alternatively, the aerosol-forming substrate may comprise a non-tobacco material. The aerosol-forming substrate may further comprise an aerosol former. Examples of suitable aerosol formers are glycerine and propylene glycol.

If the aerosol-forming substrate is a solid aerosol-forming substrate, the solid aerosol-forming substrate may comprise, for example, one or more of: powder, granules, pellets, shreds, spaghettis, strips or sheets containing one or more of: herb leaf, tobacco leaf, fragments of tobacco ribs, reconstituted tobacco, homogenised tobacco, extruded tobacco and expanded tobacco. The solid aerosol-forming substrate may be in loose form, or may be provided in a suitable container or cartridge. Optionally, the solid aerosol-forming substrate may contain additional tobacco or non-tobacco volatile flavour compounds, to be released upon heating of the substrate. The solid aerosol-forming substrate may also contain capsules that, for example, include the additional tobacco or non-tobacco volatile flavour compounds and such capsules may melt during heating of the solid aerosol-forming substrate.

As used herein, homogenised tobacco refers to material formed by agglomerating particulate tobacco. Homogenised tobacco may be in the form of a sheet. Homogenised tobacco material may have an aerosol-former content of greater than 5 percent on a dry weight basis. Homogenised tobacco material may alternatively have an aerosol former content of between 5 percent and 30 percent by weight on a dry weight basis. Sheets of homogenised tobacco material may be formed by agglomerating particulate tobacco obtained by grinding or

otherwise comminuting one or both of tobacco leaf lamina and tobacco leaf stems. Alternatively, or in addition, sheets of homogenised tobacco material may comprise one or more of tobacco dust, tobacco fines and other particulate tobacco by-products formed during, for example, the treating, handling and shipping of tobacco. Sheets of homogenised tobacco material may
5 comprise one or more intrinsic binders, that is tobacco endogenous binders, one or more extrinsic binders, that is tobacco exogenous binders, or a combination thereof to help agglomerate the particulate tobacco; alternatively, or in addition, sheets of homogenised tobacco material may comprise other additives including, but not limited to, tobacco and non-tobacco fibres, aerosol-formers, humectants, plasticisers, flavourants, fillers, aqueous and non-
10 aqueous solvents and combinations thereof.

In a particularly preferred embodiment, the aerosol-forming substrate comprises a gathered crimped sheet of homogenised tobacco material. As used herein, the term 'crimped sheet' denotes a sheet having a plurality of substantially parallel ridges or corrugations. Preferably, when the aerosol-generating article has been assembled, the substantially parallel
15 ridges or corrugations extend along or parallel to the longitudinal axis of the aerosol-generating article. This advantageously facilitates gathering of the crimped sheet of homogenised tobacco material to form the aerosol-forming substrate. However, it will be appreciated that crimped sheets of homogenised tobacco material for inclusion in the aerosol-generating article may alternatively or in addition have a plurality of substantially parallel ridges or corrugations that are
20 disposed at an acute or obtuse angle to the longitudinal axis of the aerosol-generating article when the aerosol-generating article has been assembled. In certain embodiments, the aerosol-forming substrate may comprise a gathered sheet of homogenised tobacco material that is substantially evenly textured over substantially its entire surface. For example, the aerosol-forming substrate may comprise a gathered crimped sheet of homogenised tobacco material
25 comprising a plurality of substantially parallel ridges or corrugations that are substantially evenly spaced-apart across the width of the sheet.

Optionally, the solid aerosol-forming substrate may be provided on or embedded in a thermally stable carrier. The carrier may take the form of powder, granules, pellets, shreds, spaghetti, strips or sheets. Alternatively, the carrier may be a tubular carrier having a thin layer
30 of the solid substrate deposited on its inner surface, or on its outer surface, or on both its inner and outer surfaces. Such a tubular carrier may be formed of, for example, a paper, or paper like material, a non-woven carbon fibre mat, a low mass open mesh metallic screen, or a perforated metallic foil or any other thermally stable polymer matrix.

The solid aerosol-forming substrate may be deposited on the surface of the carrier in the
35 form of, for example, a sheet, foam, gel or slurry. The solid aerosol-forming substrate may be deposited on the entire surface of the carrier, or alternatively, may be deposited in a pattern in order to provide a non-uniform flavour delivery during use.

Although reference is made to solid aerosol-forming substrates above, it will be clear to one of ordinary skill in the art that other forms of aerosol-forming substrate may be used with other examples. The liquid aerosol-forming substrate may be absorbed into a porous carrier material. The porous carrier material may be made from any suitable absorbent plug or body, 5 for example, a foamed metal or plastics material, polypropylene, terylene, nylon fibres or ceramic. The liquid aerosol-forming substrate may be retained in the porous carrier material prior to use or, alternatively, the liquid aerosol-forming substrate material may be released into the porous carrier material during, or immediately prior to use. For example, the liquid aerosol-forming substrate may be provided in a capsule. The shell of the capsule preferably melts upon 10 heating and releases the liquid aerosol-forming substrate into the porous carrier material. The capsule may optionally contain a solid in combination with the liquid.

Alternatively, the carrier may be a non-woven fabric or fibre bundle into which tobacco components have been incorporated. The non-woven fabric or fibre bundle may comprise, for example, carbon fibres, natural cellulose fibres, or cellulose derivative fibres.

15 In examples in which the at least one heating element comprises an inductor coil, the aerosol-generating article may comprise at least one susceptor element in thermal contact with the segment of aerosol-forming substrate.

The at least one susceptor element may comprise a plurality of susceptor particles. Preferably, the plurality of susceptor particles are distributed within the aerosol-forming 20 substrate.

The at least one susceptor element may comprise an internal susceptor element positioned within the segment of aerosol-forming substrate. The internal susceptor element may comprise a rod, a pin or a sheet of susceptor material positioned within the aerosol-forming substrate.

25 The at least one susceptor element may comprise an external susceptor element extending around an external surface of the segment of aerosol-forming substrate. The external susceptor element may comprise a sheet of susceptor material wrapped around at least a portion of the segment of aerosol-forming substrate.

30 Preferably, the aerosol-generating article is substantially cylindrical in shape. The aerosol-generating article may be substantially elongate. The segment of aerosol-forming substrate may be substantially cylindrical in shape. The segment of aerosol-forming substrate may be substantially elongate.

The aerosol-generating article may have a total length between approximately 30 millimetres and approximately 100 millimetres. The aerosol-generating article may have a total 35 length of approximately 45 millimetres.

The aerosol-generating article may have an external diameter between approximately 5 millimetres and approximately 12 millimetres, preferably between approximately 6 millimetres and approximately 10 millimetres, preferably between approximately 7 millimetres and

approximately 8 millimetres, preferably between approximately 7.0 millimetres and approximately 7.4 millimetres. The aerosol-generating article may have an external diameter of approximately 7.3 millimetres.

5 The segment of aerosol-forming substrate may have a length of between approximately 10 millimetres and approximately 18 millimetres. Further, the diameter of the segment of aerosol-forming substrate may be between approximately 5 millimetres and approximately 12 millimetres.

The at least one filter segment may have a length of between approximately 5 millimetres to approximately 12 millimetres. The at least one filter segment may have a length of approximately 7 millimetres.

10 Features described in relation to one of the above examples may equally be applied to other examples of the present disclosure.

The invention is defined in the claims. However, below there is provided a non-exhaustive list of non-limiting examples. Any one or more of the features of these examples may be combined with any one or more features of another example, embodiment, or aspect described herein.

Example Ex1: An aerosol-generating device comprising:

a cavity for receiving an aerosol-generating article, the cavity having a first end and a second end opposite the first end;

20 an opening at a first end of the cavity for inserting an aerosol-generating article into the cavity;

at least one heating element; and

a plurality of projections extending from an internal surface of the cavity, wherein every projection is positioned closer to the first end of the cavity than the second end of the cavity.

25 Example Ex2: An aerosol-generating device according to Example Ex1, wherein each projection has a circular cross-sectional shape.

Example Ex3: An aerosol-generating device according to Example Ex1 or Ex2, wherein each projection has a convex shape.

30 Example Ex4: An aerosol-generating device according to Example Ex1, Ex2 or Ex3, wherein each projection has a hemispherical shape.

Example Ex5: An aerosol-generating device according to Example Ex1, Ex2 or Ex3, wherein each projection has a truncated hemispherical shape.

Example Ex6: An aerosol-generating device according to Example Ex1, Ex2 or Ex3, wherein each projection has a truncated cone shape.

35 Example Ex7: An aerosol-generating device comprising:

a cavity for receiving an aerosol-generating article;

at least one heating element; and

a plurality of projections extending from an internal surface of the cavity, wherein each projection has a truncated hemispherical shape.

5 Example Ex8: An aerosol-generating device according to Example Ex7, wherein the cavity has a first end and a second end opposite the first end, wherein the aerosol-generating device further comprises an opening at a first end of the cavity for inserting an aerosol-generating article into the cavity, and wherein every projection is positioned closer to the first end of the cavity than the second end of the cavity.

Example Ex9: An aerosol-generating device according to any of Examples Ex1 to Ex6, or Example Ex8, wherein all of the projections are equidistantly spaced from the opening.

10 Example Ex10: An aerosol-generating device according to any of Examples Ex1 to Ex6, Ex8 or Ex9, further comprising an end face or a stopper defining the second end of the cavity, wherein the end face or the stopper is arranged to abut an aerosol-generating article when the aerosol-generating article is fully inserted into the cavity.

15 Example Ex11: An aerosol-generating device according to any of Examples Ex1 to Ex6, Ex8, Ex9 or Ex10, wherein the cavity comprises a length extending between the first end and the second end, and wherein a distance between the first end and each projection is less than one third of the length of the cavity.

Example Ex12: An aerosol-generating device according to any preceding Example, wherein each projection is fixed with respect to the internal surface of the cavity.

20 Example Ex13: An aerosol-generating device according to any preceding claim, wherein the projections are equidistantly spaced about a circumference of the internal surface of the cavity.

25 Example Ex14: An aerosol-generating device according to any preceding Example, wherein each projection has a maximum cross-sectional diameter of between 0.8 millimetres and 2 millimetres, preferably between 1.0 millimetre and 1.5 millimetres, preferably between 1.2 millimetres and 1.3 millimetres.

30 Example Ex15: An aerosol-generating device according to any preceding Example, wherein each projection has a height extending in a direction perpendicular to the internal surface of the cavity, and wherein the maximum height of each projection is between 0.05 millimetres and 0.5 millimetres, preferably between 0.07 millimetres and 0.3 millimetres, preferably between 0.08 millimetres and 0.2 millimetres, preferably between 0.095 millimetres and 0.1 millimetres.

35 Example Ex16: An aerosol-generating device according to any preceding Example, wherein the cavity has a circular cross-sectional shape, and wherein the internal surface of the cavity is a circumferential internal surface of the cavity.

Example Ex17: An aerosol-generating device according to Example Ex16, wherein each projection has a first end connected to the internal surface of the cavity and a second end opposite the first end, wherein the circular cross-sectional shape of the cavity has a

minimum diameter defined by the second ends of the projections, and wherein the minimum diameter is between 7.2 millimetres and 7.4 millimetres.

Example Ex18: An aerosol-generating device according to any preceding Example, wherein the plurality of projections comprises a total of five projections.

5 Example Ex19: An aerosol-generating device according to any preceding Example, wherein the at least one heating element comprises an external heating element extending around at least a portion of an external surface of the cavity.

10 Example Ex20: An aerosol-generating device according to Example Ex19, wherein the external heating element extends around only a central portion of the cavity to define a heating zone, and wherein the projections are positioned outside of the heating zone.

Example Ex21: An aerosol-generating device according to Example Ex19 in combination with Example Ex1 or Ex8, wherein the projections are positioned between the opening and the heating zone.

15 Example Ex22: An aerosol-generating device according to Example Ex19, Ex20 or Ex21, wherein the external heating element comprises a resistive heating element.

Example Ex23: An aerosol-generating device according to Example Ex19, Ex20 or Ex21, wherein the external heating element comprises an inductor coil.

20 Example Ex24: An aerosol-generating device according to any preceding Example, further comprising at least one housing portion at least partially defining the internal surface of the cavity, wherein the projections are integrally formed with the at least one housing portion.

25 Example Ex25: An aerosol-generating device according to Example Ex24, wherein the at least one housing portion comprises a first heater casing comprising an air inlet and a second heater casing defining the opening, and wherein the projections are provided on the second heater casing.

Example Ex26: An aerosol-generating device according to Example Ex25, further comprising a heating chamber arranged between the first heater casing and the second heater casing, and wherein the heating chamber, the first heater casing and the second heater casing together define the internal surface of the cavity.

30 Example Ex27: An aerosol-generating device according to Example Ex26, wherein the projections are positioned between the heating chamber and the opening.

Example Ex28: An aerosol-generating device according to Example Ex26 or Ex27, wherein the projections are positioned adjacent a downstream end of the heating chamber.

35 Example Ex29: An aerosol-generating device according to any of Examples Ex26 to Ex28 in combination with Example Ex19, wherein the external heating element extends around the heating chamber.

Example Ex30: An aerosol-generating device according to Example Ex29, wherein the external heating element extends around the heating chamber only.

Example Ex31: An aerosol-generating device according to any preceding Example, further comprising:

a power supply; and

5 a controller arranged to control a supply of power from the power supply to the at least one heating element.

Example Ex32: An aerosol-generating system comprising:

an aerosol-generating device according to any preceding Example; and

an aerosol-generating article comprising:

a segment of aerosol-forming substrate;

10 at least one further segment positioned downstream of the segment of aerosol-forming substrate; and

an outer wrapper extending around the segment of aerosol-forming substrate and the at least one further segment;

15 wherein the projections are positioned to engage a portion of the outer wrapper extending around the at least one further segment when the aerosol-generating article is fully inserted into the cavity.

Example Ex33: An aerosol-generating system according to Example Ex33, wherein the at least one further segment comprises:

20 at least one hollow tube positioned downstream of the segment of aerosol-forming substrate; and

at least one filter segment positioned downstream of the at least one hollow tube.

Example Ex34: An aerosol-generating system according to Example Ex33 or Ex34, wherein the outer wrapper is a paper outer wrapper.

25 Example Ex35: An aerosol-generating system according to Example Ex33, Ex34 or Ex35, wherein the aerosol-forming substrate comprises tobacco.

Example Ex36: An aerosol-generating system according to any of Examples Ex33 to Ex36 in combination with Example Ex24, wherein the aerosol-generating article comprises at least one susceptor element in thermal contact with the segment of aerosol-forming substrate.

Example Ex37: An aerosol-generating device comprising:

30 a cavity for receiving an aerosol-generating article;

at least one heating element; and

a plurality of projections extending from an internal surface of the cavity.

Example Ex38: An aerosol-generating device according to Example Ex37 and comprising one or more additional features from any of the preceding Examples.

35 The invention will be further described, by way of example only, with reference to the accompanying drawings in which:

Figure 1 shows a cross-sectional view of an aerosol-generating device according to an embodiment of the present disclosure;

Figure 2 shows an enlarged cross-sectional view of the heater assembly of the aerosol-generating device of Figure 1;

Figure 3 shows a further cross-sectional view of the heater assembly of Figure 2 taken along line 3-3 of Figure 2;

5 Figure 4 shows an enlarged cross-sectional view of one of the projections of the heater assembly of Figure 3;

Figure 5 shows an alternative cross-sectional shape of one of the projections of the heater assembly of Figure 3; and

10 Figure 6 shows a cross-sectional view of the heater assembly of Figure 2 with an aerosol-generating article received within the heater assembly.

Figure 1 shows a cross-sectional view of an aerosol-generating device 10 according to an embodiment of the present disclosure. The aerosol-generating device 10 comprises a housing 12 defining a device air inlet 14 at a first end of the housing 12 and a device opening 15 at a second end of the housing 12. A heater assembly 16 is positioned within the housing 12 and in fluid communication with the device air inlet 14. The aerosol-generating device 10 also comprises a power supply 18 and a controller 20 arranged to control a supply of power from the power supply 18 to the heater assembly 16. The power supply 18 is a battery and, in this example, is a rechargeable lithium ion battery.

20 Figure 2 shows an enlarged cross-section view of the heater assembly 16. The heater assembly 16 comprises a cavity 20 for receiving an aerosol-generating article and defines an opening 22 at a first end of the cavity 20. The opening 22 of the heater assembly 16 is aligned with the device opening 15 defined by the housing 12. During use, an aerosol-generating article may be inserted into the cavity 20 through the opening 22. The opening 22 may form an aerosol outlet so that, during use, aerosol may exit the cavity 20 via the opening 22. In 25 embodiments in which the aerosol-generating article extends outside of the cavity 20 through the opening 22 during use of the aerosol-generating device, the aerosol may exit the cavity 20 via the aerosol-generating article.

The heater assembly 16 also defines an air inlet 24 at a second end of the heater assembly 16, the air inlet 24 is in fluid communication with the device air inlet 14. During use, 30 air may flow through the aerosol-generating device 12 via the device air inlet 14, the heater assembly air inlet 24, the cavity 20, the heater assembly opening 22 and the device opening 15.

35 The heater assembly 16 comprises a first heater casing 26, a tubular heating chamber 28, and a second heater casing 30. The first heater casing 26 is secured to the second heating casing 30 to retain the heating chamber 28 between the first heater casing 26 and the second heater casing 30. The first heater casing 26, the heating chamber 28 and the second heater casing 30 together define the cavity 20. The first heater casing 26 defines the air inlet 24 and the second heater casing 30 defines the opening 22. Each of the first and second heater

casings 26, 30 is formed from polyetheretherketone (PEEK) and the heating chamber 28 is formed from stainless steel.

The heater assembly 16 also comprises a heating element 32 extending around an outer surface of the heating chamber 28. The heating element comprises a heat-resistant flexible polyimide film having electrically resistive heating tracks (not shown) formed in a serpentine pattern on the film. During use, the controller 20 controls a supply of power from the power supply 18 to the electrically resistive heating tracks of the heating element 32 to heat the heating chamber 28, which in turn heats a portion of an aerosol-generating article received within the heating chamber 28. The second heater casing 30 is shaped to define a space 34 around the heating chamber 28 that reduces heat losses from the heating chamber 6 and reduces heat transfer to an exterior of the heater assembly 16 and the aerosol-generating device 10. The space 34 may be an airspace filled with air, or the space 34 may be filled with a microporous insulating material.

The heater assembly 16 also comprise a plurality of projections 36 extending from an internal surface 38 of the cavity 20. Advantageously, the projections 36 provide an interference fit with an aerosol-generating article inserted into the cavity 20, which may reduce or prevent accidental movement of the aerosol-generating article with respect to the cavity 20 during use of the aerosol-generating device 10.

The projections 36 are shown in more detail in Figure 3, which shows a cross-sectional view of the heater assembly 16 along line 3-3 of Figure 2, which extend through the centre of each of the projections 36. Each projection 36 has a truncated hemispherical shape and is formed integrally with the second heater casing 30. For example, the second heating casing 30, including the projections 36, may be formed using an injection moulding process.

Advantageously, the hemispherical portion of each projection 36 facilitates sliding of an aerosol-generating article across the projections 36 when the aerosol-generating article is inserted into and removed from the cavity 20. Advantageously, this may reduce a force required to insert the aerosol-generating article into and remove the aerosol-generating article from the cavity 20. This is particularly advantageous in embodiments in which the aerosol-generating article comprises a paper wrapper, which may be relatively fragile after use due to absorption of moisture by the paper wrapper from an aerosol-forming substrate.

Advantageously, the truncated portion of each projection 36 increases an area of contact between the projections 36 and an aerosol-generating article when the aerosol-generating article is received within the cavity 20.

Figure 4 shows an enlarged cross-sectional view of one of the projections 36 to illustrate the truncated hemispherical shape of the projection 36. Figure 5 shows an alternative truncated hemispherical shape for the projection 36 that may be achieved by selecting a different truncated portion of the hemispherical shape.

The aerosol-generating device 10 comprises a total of five projections 36 spaced equidistantly about a circumference of the internal surface 38 of the cavity 20. Advantageously, spacing the projections 36 equally around the circumference helps to guide an aerosol-generating article into the correct position within the cavity 20 when the aerosol-generating article is inserted into the cavity 20.

All of the projections 36 are equally spaced from the opening 22 of the heater assembly 16 so that the projections 36 lie on a circumferential line extending around the internal surface 38 of the cavity. Each of the projections 36 has the same size and shape.

At the cross-sectional line 3-3, the cavity 20 has a maximum diameter 40 extending between opposite points on the internal surface 38 between the projections 36. The cavity 20 also has a minimum diameter 42 defined by a circle 44 extending tangentially with respect to a surface of each of the projections 36. The difference between the maximum diameter 40 and the minimum diameter 42 is equal to twice a height of each projection 36. In this embodiment, the maximum diameter 40 is 7.27 millimetres and each projection 36 has a height of 0.095 millimetres.

Each projection 36 has a maximum diameter at a base of the projection 36, the base of each projection 36 being the point at which the projection 36 meets the internal surface 38 of the cavity. In this embodiment, each projection 36 has a maximum diameter of approximately 1.3 millimetres.

The present inventors have found that the projections provide a balance between a force required to insert an aerosol-generating article into the cavity 20, a retention force that retains the aerosol-generating article in the cavity 20 during use, and a force required to remove the aerosol-generating article from the cavity 20 after use.

Figure 6 shows a cross-sectional view of the heater assembly 16 with an aerosol-generating article 100 inserted into the cavity 20. The aerosol-generating article 100 comprises an upstream segment 102 at a first end of the aerosol-generating article 100, the upstream segment 102 comprising a hollow acetate tube. When the aerosol-generating article 100 is fully inserted into the cavity 20 the first end of the aerosol-generating article 100 abuts an end of the first heater casing 26.

The aerosol-generating article 100 also comprises a segment of aerosol-forming substrate 104 downstream of the upstream segment 102. The segment of aerosol-forming substrate 104 comprises a plug comprising tobacco cut filler and glycerine. When the aerosol-generating article 100 is fully inserted into the cavity 20, the segment of aerosol-forming substrate 104 is positioned within the heating chamber 28. During use, the heating element 32 heats the heating chamber 28, which in turn heats the segment of aerosol-forming substrate 104 to generate an aerosol.

The aerosol-generating article 100 also comprises an intermediate segment 106 downstream of the segment of aerosol-forming substrate 104, the intermediate segment 106

comprising a cardboard tube. When the aerosol-generating article 100 is fully inserted into the cavity 20, the projections 36 engage the aerosol-generating article 100 about the intermediate segment 106. Advantageously, the cardboard tube forming the intermediate segment 106 is more rigid than the tobacco rod or plug forming the segment of aerosol-forming substrate 104.

5 Advantageously, positioning the projections 36 on the second heater casing 30 to engage the more rigid intermediate segment 106 may provide a more consistent and reliable interference fit between the projections 36 and the aerosol-generating article 100.

The aerosol-generating article 100 also comprises a mouth end segment 108 downstream of the intermediate segment 106 at a second end of the aerosol-generating article
10 100. The mouth end segment 108 comprises cellulose acetate fibres and may also be referred to as a filter segment or a mouthpiece. A paper outer wrapper 110 is wrapped around the segments 102, 104, 106 and 108 to secure the segments together in axial alignment.

Claims

1. An aerosol-generating device comprising:
a cavity for receiving an aerosol-generating article, the cavity having a first end and a
5 second end opposite the first end;
an opening at a first end of the cavity for inserting an aerosol-generating article into the
cavity;
at least one heating element; and
a plurality of projections extending from an internal surface of the cavity, wherein every
10 projection is positioned closer to the first end of the cavity than the second end of the cavity.
2. An aerosol-generating device according to claim 1, wherein each projection has a
circular cross-sectional shape.
- 15 3. An aerosol-generating device according to claim 1 or 2, wherein each projection has a
convex shape.
4. An aerosol-generating device according to claim 1, 2 or 3, wherein each projection has a
hemispherical shape.
20
5. An aerosol-generating device according to claim 1, 2 or 3, wherein each projection has a
truncated hemispherical shape.
6. An aerosol-generating device according to claim 1, 2 or 3, wherein each projection has a
25 truncated cone shape.
7. An aerosol-generating device comprising:
a cavity for receiving an aerosol-generating article;
at least one heating element; and
30 a plurality of projections extending from an internal surface of the cavity, wherein each
projection has a truncated hemispherical shape.
8. An aerosol-generating device according to claim 7, wherein the cavity has a first end and
a second end opposite the first end, wherein the aerosol-generating device further comprises an
35 opening at a first end of the cavity for inserting an aerosol-generating article into the cavity, and
wherein every projection is positioned closer to the first end of the cavity than the second end of
the cavity.

9. An aerosol-generating device according to any of claims 1 to 6, or claim 8, wherein all of the projections are equidistantly spaced from the opening.

10. An aerosol-generating device according to any of claims 1 to 6, 8 or 9, further comprising an end face or a stopper defining the second end of the cavity, wherein the end face or the stopper is arranged to abut an aerosol-generating article when the aerosol-generating article is fully inserted into the cavity.

11. An aerosol-generating device according to any of claims 1 to 6, 8, 9 or 10, wherein the cavity comprises a length extending between the first end and the second end, and wherein a distance between the first end and each projection is less than one third of the length of the cavity.

12. An aerosol-generating device according to any preceding claim, wherein each projection is fixed with respect to the internal surface of the cavity.

13. An aerosol-generating device according to any preceding claim, wherein the projections are equidistantly spaced about a circumference of the internal surface of the cavity.

14. An aerosol-generating device according to any preceding claim, wherein each projection has a maximum cross-sectional diameter of between 0.8 millimetres and 2 millimetres.

15. An aerosol-generating device according to any preceding claim, wherein each projection has a height extending in a direction perpendicular to the internal surface of the cavity, and wherein the maximum height of each projection is between 0.05 millimetres and 0.5 millimetres.

16. An aerosol-generating device according to any preceding claim, wherein the cavity has a circular cross-sectional shape, and wherein the internal surface of the cavity is a circumferential internal surface of the cavity.

17. An aerosol-generating device according to claim 16, wherein each projection has a first end connected to the internal surface of the cavity and a second end opposite the first end, wherein the circular cross-sectional shape of the cavity has a minimum diameter defined by the second ends of the projections, and wherein the minimum diameter is between 7.2 millimetres and 7.4 millimetres.

18. An aerosol-generating device according to any preceding claim, wherein the plurality of projections comprises a total of five projections.

19. An aerosol-generating device according to any preceding claim, wherein the at least one heating element comprises an external heating element extending around at least a portion of an external surface of the cavity.

5

20. An aerosol-generating device according to claim 19, wherein the external heating element extends around only a central portion of the cavity to define a heating zone, and wherein the projections are positioned outside of the heating zone.

10 21. An aerosol-generating device according to claim 19 in combination with claim 1 or 8, wherein the projections are positioned between the opening and the heating zone.

22. An aerosol-generating device according to claim 19, 20 or 21, wherein the external heating element comprises a resistive heating element.

15

23. An aerosol-generating device according to claim 19, 20 or 21, wherein the external heating element comprises an inductor coil.

20 24. An aerosol-generating device according to any preceding claim, further comprising at least one housing portion at least partially defining the internal surface of the cavity, wherein the projections are integrally formed with the at least one housing portion.

25 25. An aerosol-generating device according to claim 24, wherein the at least one housing portion comprises a first heater casing comprising an air inlet and a second heater casing defining the opening, and wherein the projections are provided on the second heater casing.

30 26. An aerosol-generating device according to claim 25, further comprising a heating chamber arranged between the first heater casing and the second heater casing, and wherein the heating chamber, the first heater casing and the second heater casing together define the internal surface of the cavity.

27. An aerosol-generating device according to claim 26, wherein the projections are positioned between the heating chamber and the opening.

35 28. An aerosol-generating device according to claim 26 or 27, wherein the projections are positioned adjacent a downstream end of the heating chamber.

29. An aerosol-generating device according to any of claims 26 to 28 in combination with claim 19, wherein the external heating element extends around the heating chamber.

30. An aerosol-generating device according to claim 29, wherein the external heating element extends around the heating chamber only.

31. An aerosol-generating device according to any preceding claim, further comprising:
a power supply; and
a controller arranged to control a supply of power from the power supply to the at least one heating element.

32. An aerosol-generating system comprising:
an aerosol-generating device according to any preceding claim; and
an aerosol-generating article comprising:
a segment of aerosol-forming substrate;
at least one further segment positioned downstream of the segment of aerosol-forming substrate; and
an outer wrapper extending around the segment of aerosol-forming substrate and the at least one further segment;
wherein the projections are positioned to engage a portion of the outer wrapper extending around the at least one further segment when the aerosol-generating article is fully inserted into the cavity.

33. An aerosol-generating system according to claim 32, wherein the at least one further segment comprises:
at least one hollow tube positioned downstream of the segment of aerosol-forming substrate; and
at least one filter segment positioned downstream of the at least one hollow tube.

34. An aerosol-generating system according to claim 32 or 33, wherein the outer wrapper is a paper outer wrapper.

35. An aerosol-generating system according to claim 32, 33 or 34, wherein the aerosol-forming substrate comprises tobacco.

36. An aerosol-generating system according to any of claims 32 to 35 in combination with claim 24, wherein the aerosol-generating article comprises at least one susceptor element in thermal contact with the segment of aerosol-forming substrate.

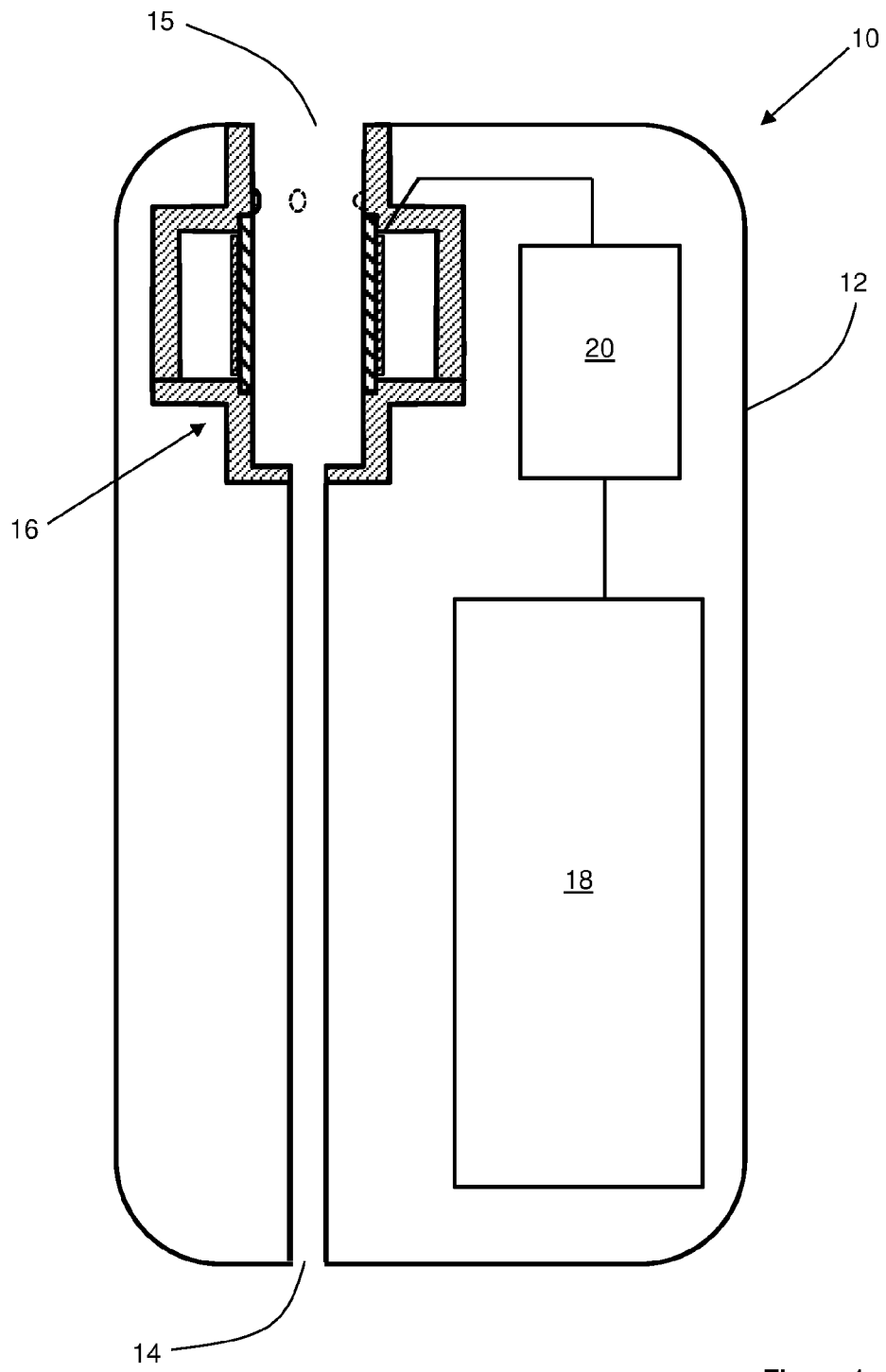

Figure 1

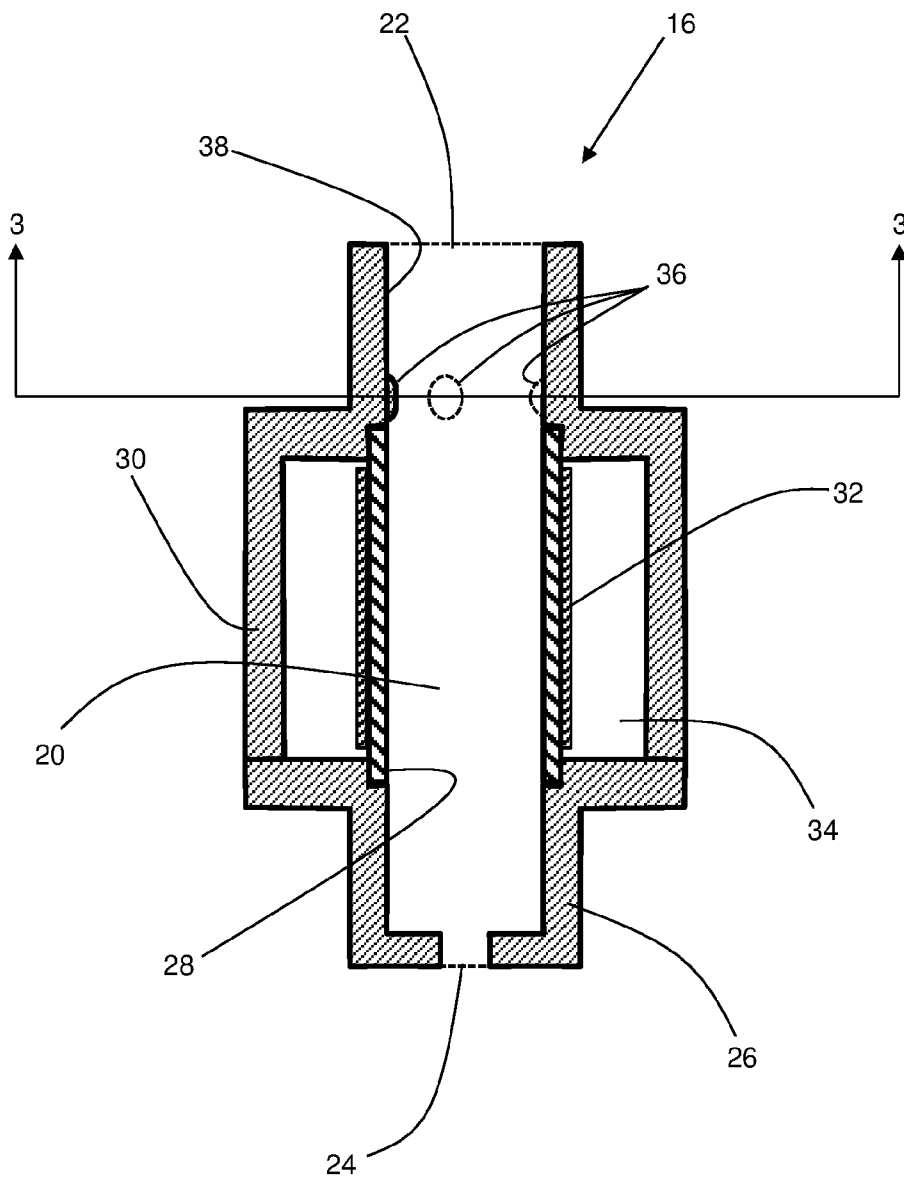

Figure 2

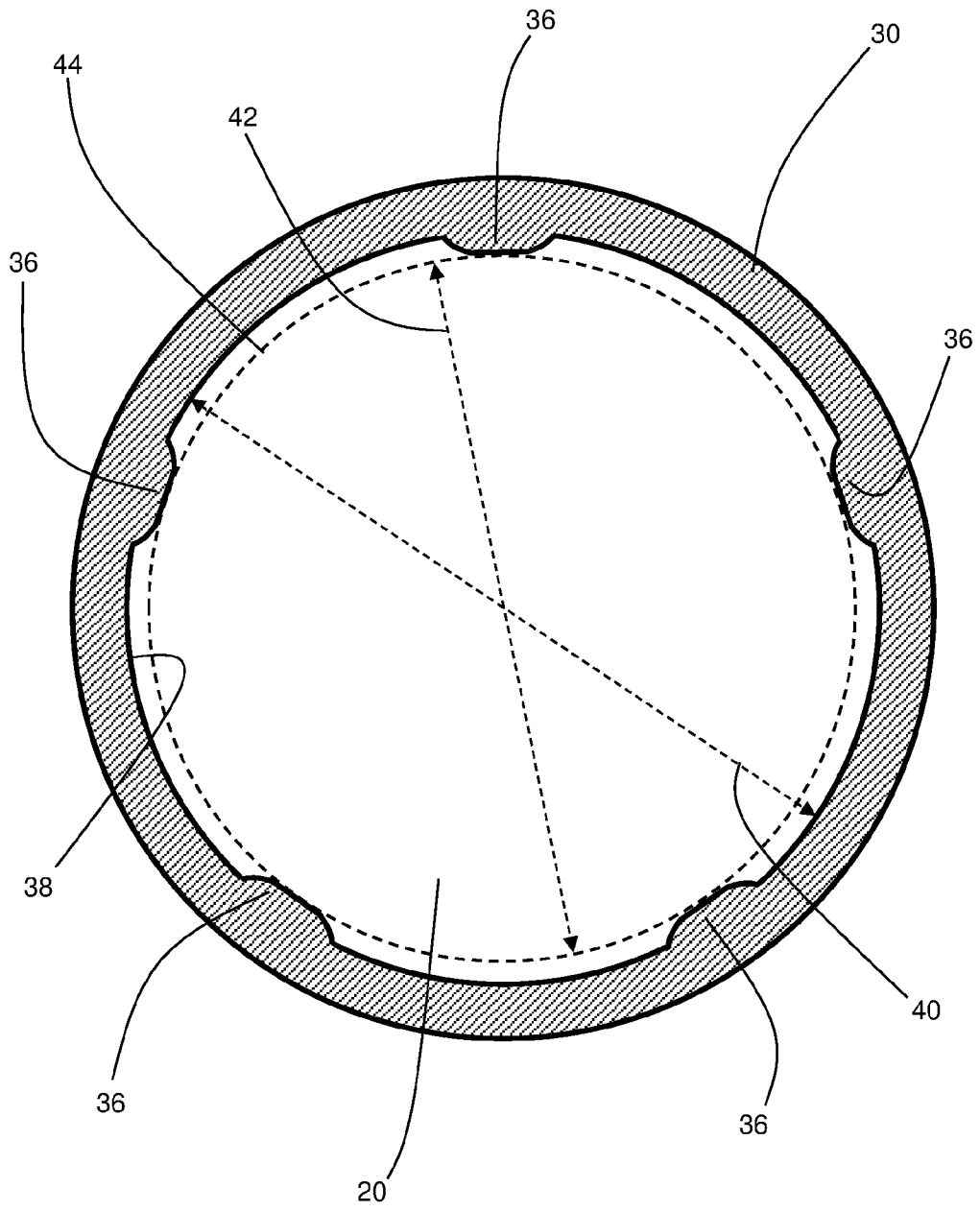

Figure 3

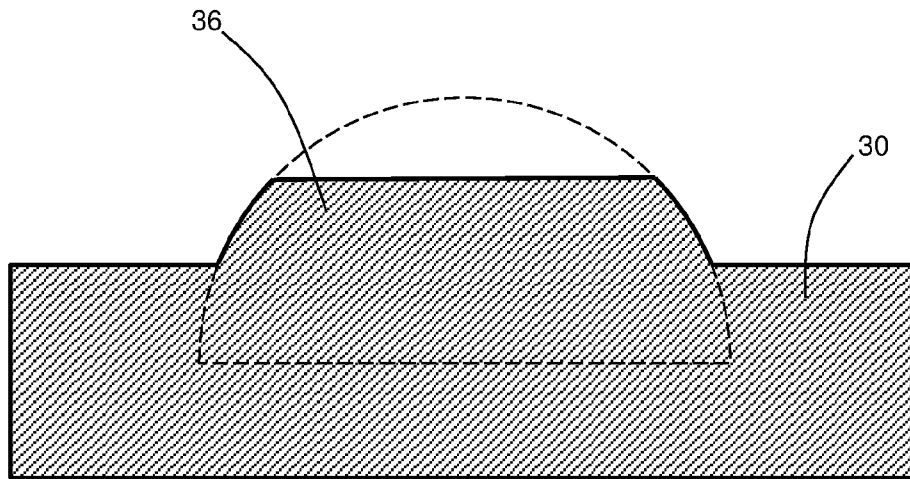

Figure 4

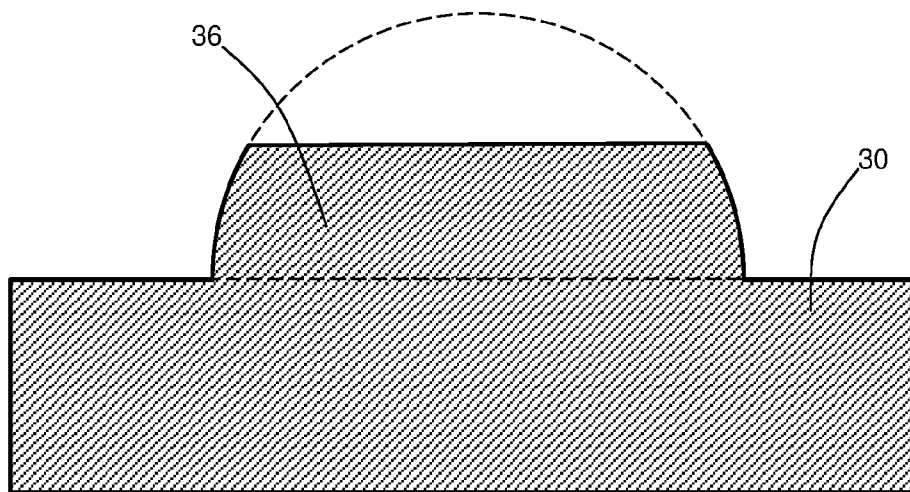

Figure 5

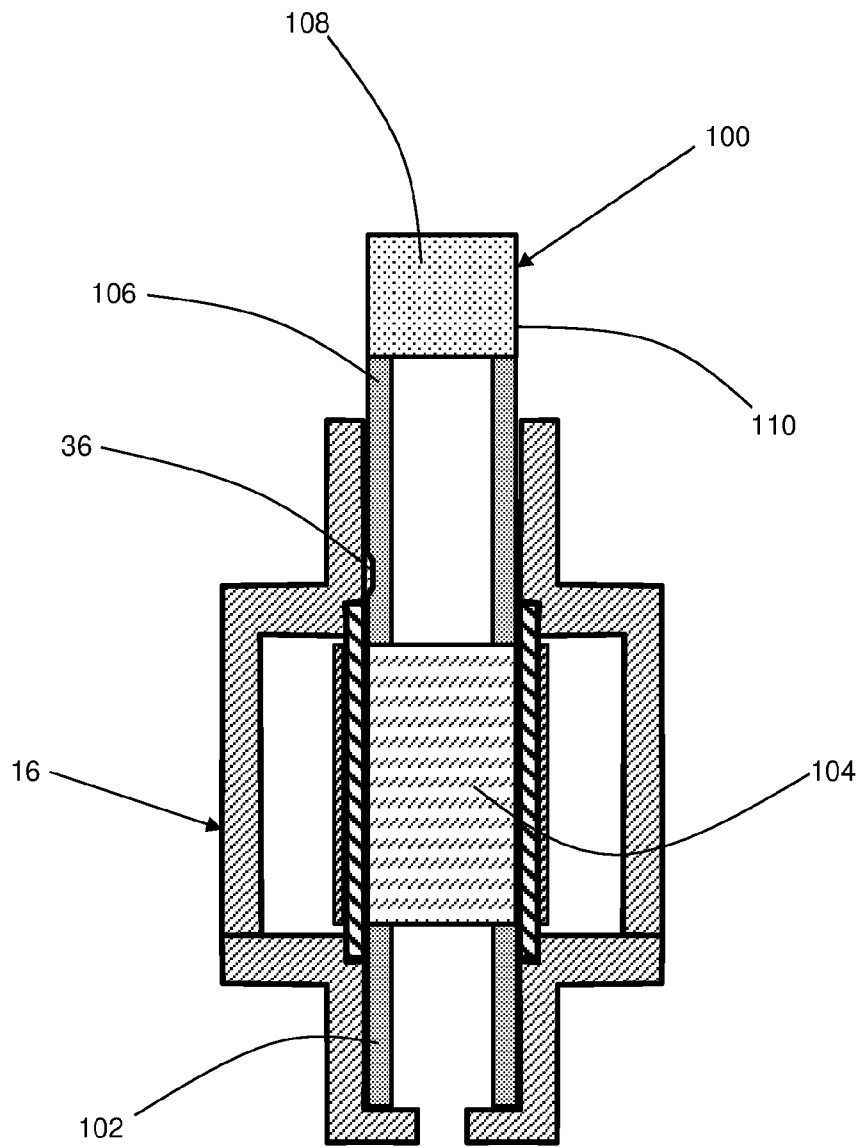

Figure 6

INTERNATIONAL SEARCH REPORT

International application No
PCT/CN2021/123535

A. CLASSIFICATION OF SUBJECT MATTER INV. A24F40/40 ADD.				
According to International Patent Classification (IPC) or to both national classification and IPC				
B. FIELDS SEARCHED				
Minimum documentation searched (classification system followed by classification symbols) A24F				
Documentation searched other than minimum documentation to the extent that such documents are included in the fields searched				
Electronic data base consulted during the international search (name of data base and, where practicable, search terms used) EPO-Internal				
C. DOCUMENTS CONSIDERED TO BE RELEVANT				
Category*	Citation of document, with indication, where appropriate, of the relevant passages	Relevant to claim No.		
X	EP 3 610 741 A1 (KT & G COPORATION [KR])	1-18,		
A	19 February 2020 (2020-02-19)	24-36		
	abstract	19-23		
	paragraphs [0001], [0040] - paragraph [0045]			
	paragraph [0055] - paragraph [0058]			
	paragraph [0072] - paragraph [0081]			
	figures 1, 2, 3, 7, 8, 14, 15, 28-30F			

X	CN 203 563 687 U (HUBEI CHINA TOBACCO IND	1-36		
	CO LTD ET AL.) 30 April 2014 (2014-04-30)			
	the whole document			

	-/--			
<table style="width: 100%; border: none;"> <tr> <td style="width: 50%; border: none;"><input checked="" type="checkbox"/> Further documents are listed in the continuation of Box C.</td> <td style="width: 50%; border: none;"><input checked="" type="checkbox"/> See patent family annex.</td> </tr> </table>			<input checked="" type="checkbox"/> Further documents are listed in the continuation of Box C.	<input checked="" type="checkbox"/> See patent family annex.
<input checked="" type="checkbox"/> Further documents are listed in the continuation of Box C.	<input checked="" type="checkbox"/> See patent family annex.			
* Special categories of cited documents :				
"A" document defining the general state of the art which is not considered to be of particular relevance "E" earlier application or patent but published on or after the international filing date "L" document which may throw doubts on priority claim(s) or which is cited to establish the publication date of another citation or other special reason (as specified) "O" document referring to an oral disclosure, use, exhibition or other means "P" document published prior to the international filing date but later than the priority date claimed	"T" later document published after the international filing date or priority date and not in conflict with the application but cited to understand the principle or theory underlying the invention "X" document of particular relevance; the claimed invention cannot be considered novel or cannot be considered to involve an inventive step when the document is taken alone "Y" document of particular relevance; the claimed invention cannot be considered to involve an inventive step when the document is combined with one or more other such documents, such combination being obvious to a person skilled in the art "&" document member of the same patent family			
Date of the actual completion of the international search	Date of mailing of the international search report			
22 March 2022	07/04/2022			
Name and mailing address of the ISA/ European Patent Office, P.B. 5818 Patentlaan 2 NL - 2280 HV Rijswijk Tel. (+31-70) 340-2040, Fax: (+31-70) 340-3016	Authorized officer Payr, Matthias			

INTERNATIONAL SEARCH REPORT

International application No
PCT/CN2021/123535

C(Continuation). DOCUMENTS CONSIDERED TO BE RELEVANT		
Category*	Citation of document, with indication, where appropriate, of the relevant passages	Relevant to claim No.
X	<p>WO 2021/044023 A1 (JT INT SA [CH]) 11 March 2021 (2021-03-11) abstract page 5, line 32 - page 6, line 18 page 15, line 30 - page 16, line 8 page 24, line 33 - page 25, line 18 figures 1-12</p> <p style="text-align: center;">-----</p>	1-36
X	<p>US 2019/230989 A1 (FURSA OLEG [CH] ET AL) 1 August 2019 (2019-08-01)</p> <p>abstract figures 1-5 paragraphs [0006], [0044] - paragraph [0048] paragraph [0059] - paragraph [0079]</p> <p style="text-align: center;">-----</p>	1, 3, 7-13, 19-21, 23-36
X	<p>WO 2021/122705 A1 (PHILIP MORRIS PRODUCTS SA [CH]) 24 June 2021 (2021-06-24)</p> <p>abstract page 27, line 30 - line 31 page 28, line 25 - page 30, line 24 figures 1-7</p> <p style="text-align: center;">-----</p>	1-8, 10, 12, 13, 19-36

INTERNATIONAL SEARCH REPORT

Information on patent family members

International application No

PCT/CN2021/123535

Patent document cited in search report	Publication date	Patent family member(s)	Publication date
EP 3610741	A1	19-02-2020	CN 110494053 A
			EP 3610741 A1
			WO 2018190606 A1

CN 203563687	U	30-04-2014	NONE

WO 2021044023	A1	11-03-2021	TW 202110347 A
			WO 2021044023 A1

US 2019230989	A1	01-08-2019	AU 2017327660 A1
			BR 112019004839 A2
			CA 3035438 A1
			CN 109640717 A
			EP 3512363 A1
			JP 2019528734 A
			KR 20190046974 A
			PH 12019500515 A1
			RU 2019110970 A
			US 2019230989 A1
			WO 2018050735 A1

WO 2021122705	A1	24-06-2021	NONE
