

(19)



(11)

EP 4 023 990 B1

(12)

EUROPEAN PATENT SPECIFICATION

(45) Date of publication and mention of the grant of the patent:

20.11.2024 Bulletin 2024/47

(21) Application number: **20461613.0**

(22) Date of filing: **30.12.2020**

(51) International Patent Classification (IPC):

F28D 9/00^(2006.01) F28F 9/00^(2006.01)

(52) Cooperative Patent Classification (CPC):

F28F 9/0075; F28D 9/0031; F28F 9/001;
F28D 2021/0082; F28D 2021/0091; F28F 2215/08;
F28F 2265/16; F28F 2265/26

(54) **A TUBE FOR A HEAT EXCHANGER**

RÖHRE FÜR EINEN WÄRMETAUSCHER

TUBE POUR ÉCHANGEUR DE CHALEUR

(84) Designated Contracting States:

**AL AT BE BG CH CY CZ DE DK EE ES FI FR GB
GR HR HU IE IS IT LI LT LU LV MC MK MT NL NO
PL PT RO RS SE SI SK SM TR**

(43) Date of publication of application:

06.07.2022 Bulletin 2022/27

(73) Proprietor: **Valeo Autosystemy SP. Z.O.O.**

32-050 Skawina (PL)

(72) Inventors:

- **BELZOWSKI, Michal**
32 050 SKAWINA (PL)
- **SZOSTEK, Dawid**
32 050 SKAWINA (PL)

• **MATYSZKOWICZ, Wojciech**

32 050 SKAWINA (PL)

• **SUS, Lukasz**

32 050 SKAWINA (PL)

(74) Representative: **Valeo Systèmes Thermiques**

Service Propriété Intellectuelle

ZA l'Agiot, 8 rue Louis Lormand

CS 80517

La Verrière

78322 Le Mesnil-Saint-Denis Cedex (FR)

(56) References cited:

WO-A1-2013/078530

WO-A1-2016/049776

WO-A1-2019/145022

DE-T5- 112014 004 308

US-A1- 2012 255 709

EP 4 023 990 B1

Note: Within nine months of the publication of the mention of the grant of the European patent in the European Patent Bulletin, any person may give notice to the European Patent Office of opposition to that patent, in accordance with the Implementing Regulations. Notice of opposition shall not be deemed to have been filed until the opposition fee has been paid. (Art. 99(1) European Patent Convention).

Description

[0001] The present invention relates to a heat exchanger. In particular, the invention relates to a heat exchanger having tubes brazed to wall of a housing of the heat exchanger. WO 2016/049776 A discloses a tube according to the preamble of claim 1.

[0002] Generally, the heat exchangers are provided in a vehicle for various operations. Particularly, charge air coolers are provided in air inlet circuit of an engine. Generally, the engine may receive air from atmosphere and the atmospheric pressure decreases with the change in elevation of the vehicle, i.e., while the vehicle traveling in elevated area such mountain regions. In such case, the fuel economy and thermal efficiency of the engine may be reduced as the engine may receive inefficient amount/pressure of air. To overcome such problems, air is pressurized (herein referred to as the "charge air") by mechanical or electric compressors, known as superchargers or turbochargers. In the forced induction engines, power output becomes a function of how much air is delivered to the cylinders. Most commonly used methods is to introduce the compressors to recapture energy from gas exhaust manifold through an expansion turbine, which pressurizes air delivered to the engine, or relay part of engine's power to motorize a supercharger, usually by a set of pulleys.

[0003] Further, pressurizing the air leads to substantial increase of its temperature. Consequently, the density of the air decreases with the temperature, because hot air is less dense than cold air. The automotive industry, like many other industrial fields, uses heat exchangers to ensure optimal temperature operating conditions for the engine. Therefore, the charge air cooler is provided in the upstream to the engine and downstream to the turbo/super-charger. The charge air cooler may dissipate heat from the charged air flowing from the turbo-charger. The charge air cooler is equipped with a set of tubes forming a heat exchange bundle between a first fluid and a second heat transfer fluid, and the heat exchange bundle being housed in a casing.

[0004] The tubes in the charge air cooler can be made of aluminum as it offers significant weight savings, and aluminum alloys also have good thermal and corrosion resistance. Due to the complexity of the charge air cooler and the small dimensions allowed, the components of the charge air coolers are assembled by brazing. Further, the tubes are typically brazed to the housing of the charge air cooler, i.e. joined by adding liquid metal to the metal parts to be joined. As these tubes are brazed over their entire surface in contact with the walls of the housing, the metal thus added forms a continuous line, thereby the assembly lacks in flexibility. It is well known that the charge air coolers are subjected to high and varied stresses during operational mode, such as thermomechanical stresses and chemical reactions with more or less aggressive environments.

[0005] In particular, there are thermal shocks caused

by a sudden and significant change in temperature, for example when opening valves equipped with sensors that measure engine temperature and allow cold engine cooling water to pass into the warmer engine air intake system. These thermal shocks lead to expansion/contraction phenomena of the tubes of heat exchanger, called thermal cycles. However, the lack of flexibility of tubes generates significant stresses, which can lead to the appearance of rupture zones in tubes. It can then be observed that these fracture zones can lead to leakage of the heat transfer fluid.

[0006] In some prior arts, the heat exchange tubes may include some breakable tabs between the tube and the housing which are intended to crack during thermal cycle. However, the breakable tabs tend to form unpredictable shapes and structures which in most cases would cause collision between the housing and the tube, especially during expansion of the tubes. Such collision may lead to mechanical stress, and finally, to malfunction of the charge air cooler due to leakage.

[0007] Accordingly, there remains a need for a heat exchanger tube with an original design that ensures greater tube flexibility and which allows to avoid collision between the remaining elements of the breakable fuse element.

[0008] The present invention therefore aims to compensate for the disadvantages of the previous art and to meet the above-mentioned constraints by proposing a tube for heat exchanger, simple in its design and in its operating mode, reliable and economical, which makes it possible to limit, or even avoid, the appearance in the tube of rupture zones linked to thermal shocks, and collision between the remaining elements of the breakable fuse element.

[0009] Another object of the present invention is such a tube for a heat exchanger providing a support on the opposite walls of the casing with a view to its assembly by brazing with a complementary tube to form a conduit for the circulation of a heat transfer fluid.

[0010] The present invention is also intended for a heat exchanger comprising at least one such tube for an exchanger, so as to present enhanced reliability. For this purpose, the invention concerns a tube for a heat exchanger, said tube comprising a coupling edge to another tube.

[0011] According to the invention, said edge comprises at least one fusible part for assembling this coupling edge with at least one housing wall, said at least one fusible part being configured to be separated from the rest of said coupling edge by differential expansion/contraction between said tube and said at least one housing wall on which it is intended to be assembled. The tip portion of the fusible part extends beyond the coupling edge of the tube.

[0012] In the present description, some elements or parameters may be indexed, such as a first element and a second element. In this case, unless stated otherwise, this indexation is only meant to differentiate and name elements which are similar but not identical. No idea of

priority should be inferred from such indexation, as these terms may be switched without betraying the invention. Additionally, this indexation does not imply any order in mounting or use of the elements of the invention.

[0013] In view of forgoing, the present invention relates a tube for a heat exchanger. The tube includes at least one fusible part formed on at least one coupling edge of the tube for assembling with at least one wall of the heat exchanger. Further, the fusible part is parallelly aligned with respect to a general plane (P1) of the tube. The tube is a flat tube assembled of two half-plates so that it comprises two flat walls joined along at least two coupling edges, wherein the two coupling edges define a general plane. The tube further includes a base portion located in the vicinity of the coupling edge and a tip portion located in the vicinity of the wall of the heat exchanger. The tip portion of the fusible part is adapted to be entirely separated from the wall by differential in expansion and contraction between the tube and the wall.

[0014] In one embodiment, the tube further includes at least one notch located on the corner area of the tube, in particular the notch being located between the coupling edge and base portion of the fusible part.

[0015] Further, the fusible part is formed at the corners of the coupling edge of the tube.

[0016] In one embodiment, the tip portion of the fusible part is narrower than the base portion to facilitate separation of the tube from the wall.

[0017] Further, the coupling edge is formed to delimit the tube formed by two plates assembled with each other with their respective opposite faces.

[0018] Further, the coupling edges are intended to delimit a conduit for the circulation of a heat-transfer fluid within the tube.

[0019] In one embodiment, the fusible part is of a trapezoidal shape, wherein the width of the tip portion is smaller than of the width of the base portion.

[0020] Further, the fusible part includes sloping edges connecting the tip portion with the base portion.

[0021] In another embodiment, the fusible part is of a triangular shape.

[0022] Preferably, the fusible part is half the thickness of the tube, wherein the thickness is measured in a direction perpendicular to the general plane (P1) of the tube.

[0023] Alternatively, the fusible part is thicker than half the thickness of the tube, wherein the thickness is measured in a direction perpendicular to the general plane (P1) of the tube.

[0024] Alternatively, the fusible part is thinner than half the thickness of the tube, wherein the thickness is measured in a direction perpendicular to the general plane (P1) of the tube.

[0025] Other characteristics, details and advantages of the invention can be inferred from the description of the invention hereunder. A more complete appreciation of the invention and many of the attendant advantages thereof will be readily obtained as the same becomes

better understood by reference to the following detailed description when considered in connection with the accompanying figures, wherein:

5 Fig. 1 illustrates a perspective view of a heat exchanger, in accordance with an embodiment of the present invention;

10 Fig. 2 illustrates a side view of the heat exchanger with a detailed view of a tube-housing assembly, according to a state of the art;

15 Fig. 3 illustrates a perspective view of a standalone tube for the heat exchanger of Fig 1;

20 Fig. 4 illustrates a perspective view of a corner section of the tube shown in Fig. 3;

25 Fig. 5 illustrates a top view of a fusible part of the Fig. 3, formed on the coupling edge of the tube; and

30 Fig. 6 illustrates a front view of the fusible part of the Fig. 3, formed on the coupling edge of the tube.

35 **[0026]** It must be noted that the figures disclose the invention in a detailed enough way to be implemented, said figures helping to better define the invention if needs be. The invention should however not be limited to the embodiment disclosed in the description.

40 **[0027]** The present invention may disclose a heat exchanger tube having at least one fusible part provided in a heat exchanger. Conventionally, the heat exchanger may include bundle of tubes disposed between two manifolds and forming a fluid channel. The tubes may be brazed to the inner wall of a housing of the heat exchanger. During operation of heat exchanger, the tubes may undergo various thermal cycle. As a result, thermal stress may act on the tubes, which may lead to the appearance of rupture zones in the tubes. Further, such fracture/rupture zones can lead to leakage of the heat transfer fluid. To avoid such problems, tabs are provided at a coupling edge of the tube of the heat exchanger. Such tabs can be fusible part adapted to break when there is a differential expansion and contraction between tubes and corresponding wall of the heat exchanger.

45 **[0028]** Fig. 1 illustrates a perspective view of a heat exchanger 100, in accordance with an embodiment of the present invention. The heat exchanger 100 may include three walls forming a housing 150. The three walls being a first wall 110, a second wall 120 and a third wall 130, wherein the first wall 110 and the second wall 120 are aligned parallelly and spaced from each other, and the third wall 130 may be aligned perpendicularly with respect to the first and the second walls 110, 120, so that the opposite edges of the third wall 130 are in contact with the first wall 110, as well as the second wall 120.

50 **[0029]** The heat exchanger 100 may further comprise a manifold 140. The manifold 140 may be located paral-

lley with respect to the third wall 130 and perpendicularly with respect to the first and the second walls 110, 120, so that, similarly to the third wall 130, the opposite edges of the manifold 140 are in contact with the first wall 110, as well as the second wall 120.

[0030] The walls 110, 120, 130 and the manifold 140 may be joined together, e.g. by brazing, so that the walls 110, 120, 130 and the manifold 140 form an essentially rectangular fluid tight housing 150 which delimits a first fluid circuit for a first fluid, e.g. charge air. The housing 150 may further receive intake and outtake (not shown) for the first fluid on its open ends. The exemplary first fluid flow direction from intake to outtake is depicted in Fig.1 by F_{in} and F_{out} , respectively

[0031] Further, a second fluid circuit for a second fluid may be formed, inter alia, by the manifold 140, which may include an inlet spigot 142 and an outlet spigot 144 for delivering or collecting second fluid, e.g. coolant. The exemplary second fluid flow direction from the inlet to the outlet is depicted in Fig. 1 by W_{in} and W_{out} , respectively. The second fluid circuit further includes at least one tube 102 located within the housing 150. In this example, the term "within" means that the tube 102 does not protrude beyond the space delimited by the housing 150. The tube 102 is aligned substantially in parallel with respect to the first wall 110 and the second wall 120, and in perpendicular to the manifold 150 and the third wall 130.

[0032] Further, the tube 102 extends from the manifold 140 to the third wall 130, whereas it is fluidly connected only with the manifold 140. The tube 102 is formed, so as to enable at least one U-turn at the path of the second fluid flowing there through. Generally, the manifold 140 is configured to deliver and/or collect the second fluid to the tube 102 through two parallel channels formed therein. Preferably, the channels in the manifold 150 are formed as a unitary element with e.g. partition, however other means of providing channels for the second fluid are also envisaged.

[0033] Usually, the heat exchanger 100 may include a plurality of tubes 102 to improve the efficiency thereof. The tubes 102 are stacked one on the other in a parallel manner, perpendicularly to the manifold 140, so that the second fluid is distributed as homogeneously as possible. The second fluid may flow through the inlet W_{in} and it is directed to respective channel of the manifold 140 which feeds the tubes 102. Next, the second fluid flows through the U-shaped tube 102 back to the manifold 150 and then it is collected by the second fluid outlet W_{out} .

[0034] In order to improve the heat exchange efficiency, the stack of tubes 102 may be interlaced with so-called turbulators or fins 160. The number of turbulators or fins 160 interlaced between the tubes 102 corresponds to the free spaces in the vicinity of the tubes 102. In other words, turbulators or fins 160 fill the spaces not occupied by other sub-components within the housing 140 in order to maximize the heat exchange efficiency and to reduce bypassing of the tubes 102 by the first fluid. In this present example, the heat exchanger 100 is a charge air cooler.

In such case, the first fluid being a charged air and the second fluid being a heat transfer fluid, i.e., coolant or water or water-glycol mixture.

[0035] Fig. 2 illustrates the heat exchanger 100 with plurality of tubes 102 in accordance to a prior art. The turbulators or fins 160 are omitted for the sake of clarity. The heat exchanger 100 may be oriented horizontally. Horizontal orientation of the heat exchanger 100 refers to horizontal direction of stacking of its tubes 1. Alternatively, the heat exchanger 100 could be oriented at any angle with respect to horizontal orientation as long as the first and second fluids are efficiently delivered to provide effective heat exchange between them. As shown in Fig. 2, each tube 102 may be formed out of two half-plates produced in the same process, wherein one half-plate is substantially a mirror image of the other to delimit the path for the circulation of a heat transfer fluid between these half-plates. Alternatively, the tube 102 may be a folded tube.

[0036] Fig. 2 further shows detailed section "S1" of an assembly of the tube 102 with the housing 140. According to the prior art, the tubes 102 are stacked and spaced from each other in order to provide good efficiency of the entire heat exchanger 100. During the operational mode the heat exchanger 100, the tubes 102 expands and contracts depending on the temperature of the first and the second fluids, as well as the temperature difference between them in different sections of the heat exchanger 100. Further, the different sub-components of the heat exchanger 100 may expand or contract to different extent, because the heat is not usually distributed evenly across all sub-components.

[0037] Each tube may be formed out of two half-plates produced in the same process, wherein one half-plate is substantially a mirror image of the other to delimit the path for the circulation of a heat transfer fluid between these half-plates. In other words, the tube may be the flat tube assembled of two half-plates so that it comprises two flat walls joined along at least two coupling edges 104.

[0038] The tubes 102 may be initially, i.e. in a pre-operational mode, secured both to the manifold 140 and the third wall 130, yet it may be possible for the tubes 102 to be secured only the manifold 140. As the tubes 102 are directly connected to the housing 102, the tubes 102 may lack flexibility, thereby the tubes may damage and cause leakage of the second fluid. To avoid such problem, a fusible part is introduced in the tubes 102. Schematic and geometry of the fusible part is described in the forthcoming figures.

[0039] Figs. 3 and 4 illustrates isometric views of the standalone tube 102 and one of the corner areas of the tube 102 of Fig. 1. In one embodiment, each tube 102 may have essentially rectangular shape, so that a general plane (P1) may be defined. In this example, the general plane (P1) of the tube 102 is defined along the contact area of two half-plates. In other words, the general plane (P1) of the tube 102 runs parallelly and in-between the

half-plates of particular tube 102. In other words, the general plane (P1) may cross the median section the tube 102, so that the conduit for the first fluid in both sections thereof is split into two even halves.

[0040] As shown in Fig. 3, the tube 102 may further include a coupling edge 104 for coupling two half-plates. As discussed above, the coupling edge 104 may delimit the tube 104 formed by the two plates assembled with each other with their respective opposite faces and may delimit a conduit for the circulation of the second fluid, i.e., heat-transfer fluid within the tube 102. The coupling edge 104 may include at least one fusible part 202 for assembling the coupling edge 104 with at least one wall of the heat exchanger 100, in particular the third wall 130 of the housing 150. Further, the tube 102 may include a fluid inlet 106 and a fluid outlet 108, as shown in Fig. 3. Each of the fluid inlet 106 and fluid outlet 108 may include a collar configured to provide a fluid-tight connection between tube 102 and the manifold 140 of the heat exchanger 100.

[0041] Thus, in preferred embodiment of an invention, the tube 102 is fixed to the housing 150 with one end, and the other ought to be a free end during the operational mode of the heat exchanger 100, in order to allow expansion or contraction of the tube 102 within the housing 150.

[0042] Fig. 4 illustrates in detail a fragment of the same tube 102 as shown in Fig. 3. In particular, Fig. 4 shows one of the corner areas of the tube 102 having the fusible part 202. The fusible part 202 is parallelly aligned with respect to the general plane "P1" of the tube 102. The fusible part 202 includes a base portion 204 located in the vicinity of the coupling edge 104 and a tip portion 206 located/defined in the vicinity of the wall, particularly third wall 130, of the heat exchanger 100. In one embodiment, the tip portion 206 of the fusible part 202 is in-contact with the third wall 130. In another embodiment, the tip portion 206 of the fusible part 202 may be formed in such a way that a gap defined in between the tip portion 206 and the third wall 130. The tip portion 206 is adapted to be entirely separated from the third wall 130 by differential in expansion and contraction between the tube 102 and the third wall 130 of the heat exchanger 100.

[0043] Figs. 5 and 6 illustrate top and front views of the fusible part 202 of the Fig. 3, formed on the coupling edge 104 of the tube 102. As shown in Fig. 5, the tip portion 206 is in-contact with the third wall 130 of the housing 150. When the tube 102 expands or contracts due to thermal cycles, the fusible part 202 may break or entirely separated from the third wall 130, particularly the tip portion 206, which is in contact with the third wall 130, may break, thereby preventing collation of tube 102 with the third wall 120 and damages of the tube 102. The tube 102 further includes at least one notch 208 located on the corner area of the tubes 102, particularly, the notch 208 being located between the coupling edge 104 of the tube 102 and the base portion 204 of the fusible part 202. In this present embodiment, the tip portion 206 of the

fusible part 202 is narrower than the base portion 204 of the fusible part 202 to facilitate separation of the tube 102 from the third wall 130. The fusible part 202 is formed at the corners of the coupling 104 of the tube 102. Further, the tip portion 206 of the fusible part 202 extends beyond the coupling edge 104 of the tube 104, so the tube 102 can be separated from the walls of the housing 150. As the tip portion 206 of the fusible part 202 is extended beyond the coupling edge 104 of the tube 102, the fusible part 202, particularly the tip portion 206, can break when the tube 102 is subjected to differential expansion or contractions due to various thermal cycles.

[0044] As shown in Fig. 5, the fusible part 202 is of a trapezoidal shape, in which the tip portion 206 is narrower than the base portion 204 of the fusible part 202. Further, the width of the tip portion 206 is smaller than of the width of the base portion 204, so that the tip portion 206 can be easily separated from the third wall 130 by differential in expansion or contraction between the tube 102 and the housing 150. Further, the fusible part 202 includes sloping edges 210 connecting the tip portion 206 with the base portion 204 of the fusible part 202. In one example, the tip portion 206 of the fusible part 202 is brazed to the housing 150, particularly to the third wall 130. In another example, the tip portion 206 is just in-contact with the housing 150, particularly with the third wall 130. In another embodiment, the fusible part 202 is of a triangular shape.

[0045] As discussed above, the tip portion 206 may be configured to be separated from the fusible part 202 by differential in expansion or contraction between the tube 102 and at least one wall on which it is intended to be assembled, such as the third wall 130. During the first thermal cycles, the stress put between the tubes 102 and the housing 150 allows the notch 208 to separate the tip portion 206 from the fusible part 202, thereby the tip portion 206 may break. Consequently, the base portion 204 of the fusible part 292 is integral with the tube 102 and the tip portion 206 is integral with the housing 150, in particular the third wall 130, in case the tip portion 206 is brazed with the housing 150.

[0046] Preferably, the fusible part 202 may be half the thickness of the tube 102, in which the thickness is measured in a direction perpendicular to the general plane (P1) of the tube 102. In other words, each fusible part 202 protruding from one corner area of the tube 102 is of the same thickness as the half-plate of the tube 102 from which the fusible part 202 protrudes there-from. Alternatively, the fusible part 202 protruding from one corner area of the tube 102 is thicker than the half-plate of the tube 102 from which the fusible part 202 protrudes there-from. Alternatively, the fusible part 202 protruding from one corner area of the tube 102 is thinner than the half-plate of the tube 102 from which the fusible part 202 protrudes there-from.

[0047] As the notch 208 is provided between the coupling edge 104 of the tube 102 and the base portion 204 of the fusible part 202, the tip portion 206 can be easily

separated from the fusible part 202 when there is a differential expansion and contraction between the tube 102 and the housing 150. In other words, the notch 208 allows the tip portion 206 be separated from the base portion 204 in such a way, that during the operational mode of the heat exchanger 100, the tube 102 does not collide with the housing 150 or the contact between these elements is very gentle. This allows to significantly improve the thermal resistance of the whole heat exchanger 100. To achieve similar effect, those skilled in the art could, for example, increase the size of the housing 150 in the direction parallel to the general plane (P1) of the tube 102, so that the tubes can expand and contract freely, yet it would create several problems, such as increased packaging, reduced thermal efficiency of the heat exchanger, and other

[0048] In any case, the invention cannot and should not be limited to the embodiments specifically described in this document, as other embodiments might exist. The invention is defined by the claims.

Claims

1. A tube (102) for a heat exchanger (100) comprising at least one fusible part (202) formed on at least one coupling edge (104) of the tube (102) for assembling with at least one wall (130) of the heat exchanger (100) **characterised in that** the fusible part (202) is parallelly aligned with respect to a general plane (P1) of the tube (102), wherein the fusible part (202) comprises a base portion (204) located in the vicinity of the coupling edge (104) and a tip portion (206) located in the vicinity of the wall (130) of the heat exchanger (100), wherein the tip portion (206) of the fusible part (202) is adapted to be entirely separated from the wall (130) by differential in expansion and contraction between the tube (102) and the wall (130), wherein the tip portion (206) of the fusible part (202) extends beyond the coupling edge (104) of the tube (102).
2. The tube (102) according to claim 1, the tube (102) further comprises at least one notch (208) located on the corner area of the tube (102), in particular the notch (208) being located between the coupling edge (104) and base portion (204) of the fusible part (202).
3. The tube (102) according to any of the preceding claims, wherein the fusible part (202) is formed at the corners of the coupling edge (104) of the tube (102).
4. The tube (102) according to any of the preceding claims, wherein the tip portion (206) of the fusible part (202) is narrower than the base portion (204) to facilitate separation of the tube (102) from the wall (130)

5. The tube (102) according to any of the preceding claims, wherein the coupling edge (104) is formed to delimit the tube (102) formed by two plates assembled with each other with their respective opposite faces.
6. The tube (102) according to any of the preceding claims, wherein the coupling edges (104) are intended to delimit a conduit for the circulation of a heat-transfer fluid within the tube (102).
7. The tube (102) according to any of the preceding claims, wherein the fusible part (202) is of a trapezoidal shape, wherein the width of the tip portion (206) is smaller than of the width of the base portion (204).
8. The tube (102) according to claim 7, the fusible part (202) further comprises sloping edges (210) connecting the tip portion (206) with the base portion (204).
9. The tube (102) according to any of the claims 1 to 6, wherein the fusible part (202) is of a triangular shape.
10. The tube (102) according to any of the preceding claims, wherein the fusible part (202) is half the thickness of the tube (102), wherein the thickness is measured in a direction perpendicular to the general plane (P1) of the tube (102).
11. The tube (102) according to any of the preceding claims, wherein the fusible part (202) is thicker than half the thickness of the tube (102), wherein the thickness is measured in a direction perpendicular to the general plane (P1) of the tube (102).
12. The tube (102) according to any of the preceding claims, wherein the fusible part (202) is thinner than half the thickness of the tube (102), wherein the thickness is measured in a direction perpendicular to the general plane (P1) of the tube (102).

Patentansprüche

1. Röhre (102) für einen Wärmetauscher (100), umfassend mindestens einen schmelzbaren Teil (202), der an mindestens einer Verbindungskante (104) der Röhre (102) zur Montage mit mindestens einer Wand (130) des Wärmetauschers (100) ausgebildet ist, **dadurch gekennzeichnet, dass** der schmelzbare Teil (202) parallel zu einer allgemeinen Ebene (P1) der Röhre (102) ausgerichtet ist, wobei der schmelzbare Teil (202) einen Basisabschnitt (204), der sich in der Nähe der Verbindungskante (104) befindet, und einen Spitzenabschnitt

- (206), der sich in der Nähe der Wand (130) des Wärmetauschers (100) befindet, umfasst, wobei der Spitzenabschnitt (206) des schmelzbaren Teils (202) so ausgelegt ist, dass er durch unterschiedliche Ausdehnung und Kontraktion zwischen der Röhre (102) und der Wand (130) vollständig von der Wand (130) getrennt wird, wobei sich der Spitzenabschnitt (206) des schmelzbaren Teils (202) über die Verbindungskante (104) der Röhre (102) hinaus erstreckt.
2. Röhre (102) nach Anspruch 1, wobei die Röhre (102) ferner mindestens eine Kerbe (208) aufweist, die sich im Eckbereich der Röhre (102) befindet, insbesondere wobei sich die Kerbe (208) zwischen der Verbindungskante (104) und dem Basisabschnitt (204) des schmelzbaren Teils (202) befindet.
 3. Röhre (102) nach einem der vorhergehenden Ansprüche, wobei der schmelzbare Teil (202) an den Ecken der Verbindungskante (104) der Röhre (102) ausgebildet ist.
 4. Röhre (102) nach einem der vorhergehenden Ansprüche, wobei der Spitzenabschnitt (206) des schmelzbaren Teils (202) schmaler als der Basisabschnitt (204) ist, um die Trennung der Röhre (102) von der Wand (130) zu erleichtern.
 5. Röhre (102) nach einem der vorhergehenden Ansprüche, wobei die Verbindungskante (104) so ausgebildet ist, dass sie die Röhre (102) begrenzt, die durch zwei Platten gebildet wird, die mit ihren jeweiligen gegenüberliegenden Flächen miteinander montiert sind.
 6. Röhre (102) nach einem der vorhergehenden Ansprüche, wobei die Verbindungskanten (104) dazu bestimmt sind, einen Kanal zur Zirkulation eines Wärmeübertragungsfluids innerhalb der Röhre (102) zu begrenzen.
 7. Röhre (102) nach einem der vorhergehenden Ansprüche, wobei der schmelzbare Teil (202) eine Trapezform aufweist, wobei die Breite des Spitzenabschnitts (206) kleiner als die Breite des Basisabschnitts (204) ist.
 8. Röhre (102) nach Anspruch 7, wobei der schmelzbare Teil (202) ferner abgeschrägte Kanten (210) umfasst, die den Spitzenabschnitt (206) mit dem Basisabschnitt (204) verbinden.
 9. Röhre (102) nach einem der Ansprüche 1 bis 6, wobei der schmelzbare Teil (202) eine dreieckige Form aufweist.
 10. Röhre (102) nach einem der vorhergehenden Ansprüche, wobei der schmelzbare Teil (202) halb so dick wie die Röhre (102) ist, wobei die Dicke in einer Richtung rechtwinklig zur allgemeinen Ebene (P1) der Röhre (102) gemessen wird.
 11. Röhre (102) nach einem der vorhergehenden Ansprüche, wobei der schmelzbare Teil (202) dicker als die Röhre (102) ist, wobei die Dicke in einer Richtung rechtwinklig zur allgemeinen Ebene (P1) der Röhre (102) gemessen wird.
 12. Röhre (102) nach einem der vorhergehenden Ansprüche, wobei der schmelzbare Teil (202) dünner als die Hälfte der Dicke der Röhre (102) ist, wobei die Dicke in einer Richtung rechtwinklig zur allgemeinen Ebene (P1) der Röhre (102) gemessen wird.

Revendications

1. Tube (102) pour échangeur de chaleur (100) comprenant au moins une partie fusible (202) formée sur au moins un bord de couplage (104) du tube (102) pour assemblage avec au moins une paroi (130) de l'échangeur de chaleur (100) **caractérisé en ce que** la partie fusible (202) est alignée parallèlement par rapport à un plan général (P1) du tube (102), la partie fusible (202) comprenant une portion base (204) située à proximité du bord de couplage (104) et une portion pointe (206) située à proximité de la paroi (130) de l'échangeur de chaleur (100), la portion pointe (206) de la partie fusible (202) étant conçue pour être entièrement séparée de la paroi (130) par différentiel de dilatation et de contraction entre le tube (102) et la paroi (130), la portion pointe (206) de la partie fusible (202) s'étendant au-delà du bord de couplage (104) du tube (102) .
2. Tube (102) selon la revendication 1, le tube (102) comprend en outre au moins une encoche (208) située sur la zone de coin du tube (102), en particulier l'encoche (208) étant située entre le bord de couplage (104) et la portion base (204) de la partie fusible (202).
3. Tube (102) selon l'une quelconque des revendications précédentes, dans lequel la partie fusible (202) est formée au niveau des coins du bord de couplage (104) du tube (102).
4. Tube (102) selon l'une quelconque des revendications précédentes, dans lequel la portion pointe (206) de la partie fusible (202) est plus étroite que la portion base (204) pour faciliter la séparation du tube (102) de la paroi (130).
5. Tube (102) selon l'une quelconque des revendications précédentes, dans lequel le bord de couplage

(104) est formé pour délimiter le tube (102) formé par deux plaques assemblées l'une à l'autre avec leurs faces opposées respectives.

6. Tube (102) selon l'une quelconque des revendications précédentes, dans lequel les bords de couplage (104) sont censés délimiter un conduit de circulation d'un fluide caloporteur au sein du tube (102). 5
7. Tube (102) selon l'une quelconque des revendications précédentes, dans lequel la partie fusible (202) est de forme trapézoïdale, dans lequel la largeur de la portion pointe (206) est inférieure à la largeur de la portion base (204). 10
8. Tube (102) selon la revendication 7, la partie fusible (202) comprend en outre des bords inclinés (210) raccordant la portion pointe (206) à la portion base (204). 15
9. Tube (102) selon l'une quelconque des revendications 1 à 6, dans lequel la partie fusible (202) est de forme triangulaire. 20
10. Tube (102) selon l'une quelconque des revendications précédentes, dans lequel la partie fusible (202) fait la moitié de l'épaisseur du tube (102), l'épaisseur étant mesurée dans une direction perpendiculaire au plan général (P1) du tube (102). 25
11. Tube (102) selon l'une quelconque des revendications précédentes, dans lequel la partie fusible (202) fait plus de la moitié de l'épaisseur du tube (102), l'épaisseur étant mesurée dans une direction perpendiculaire au plan général (P1) du tube (102). 30
12. Tube (102) selon l'une quelconque des revendications précédentes, dans lequel la partie fusible (202) fait moins de la moitié de l'épaisseur du tube (102), l'épaisseur étant mesurée dans une direction perpendiculaire au plan général (P1) du tube (102). 35

45

50

55

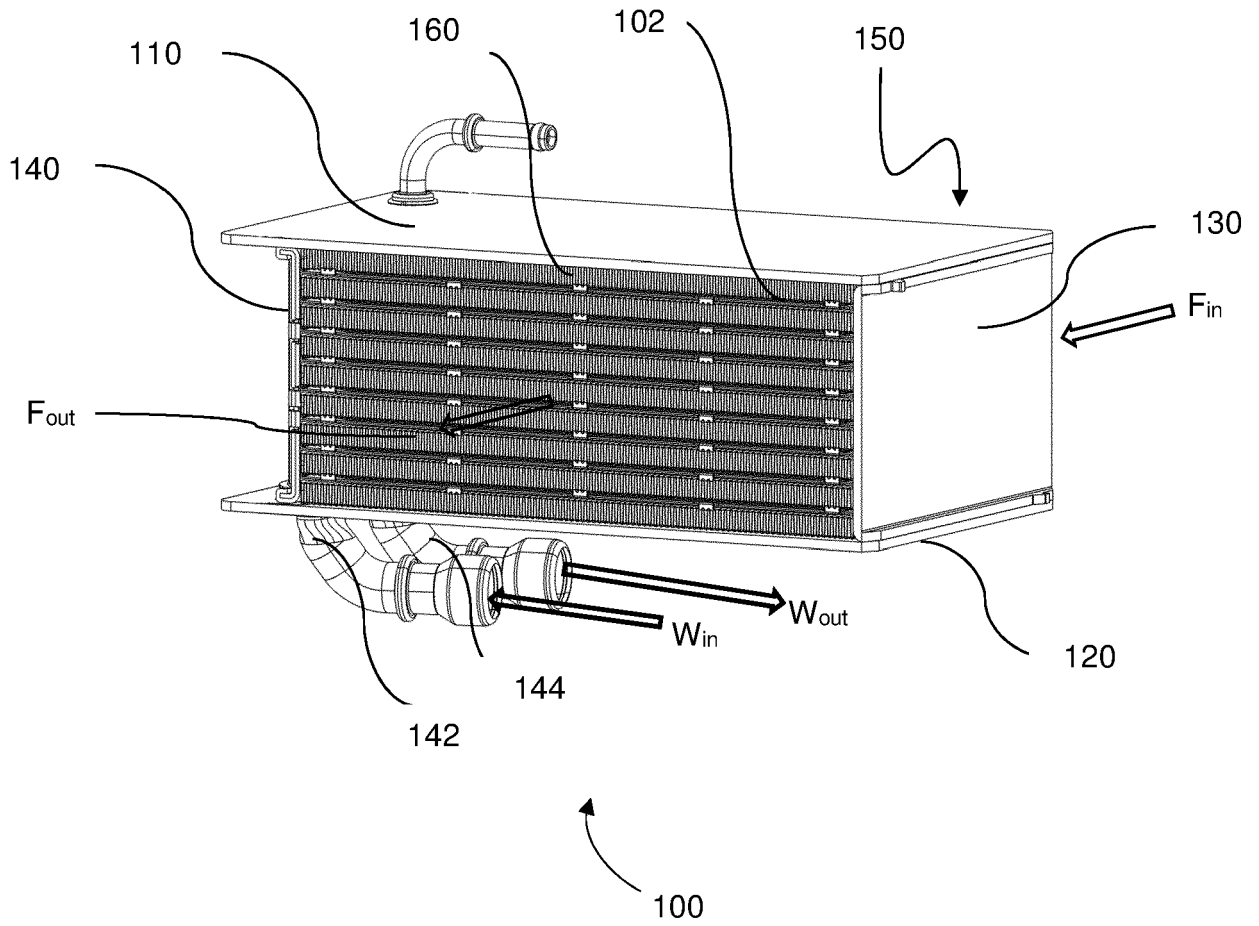

Fig. 1

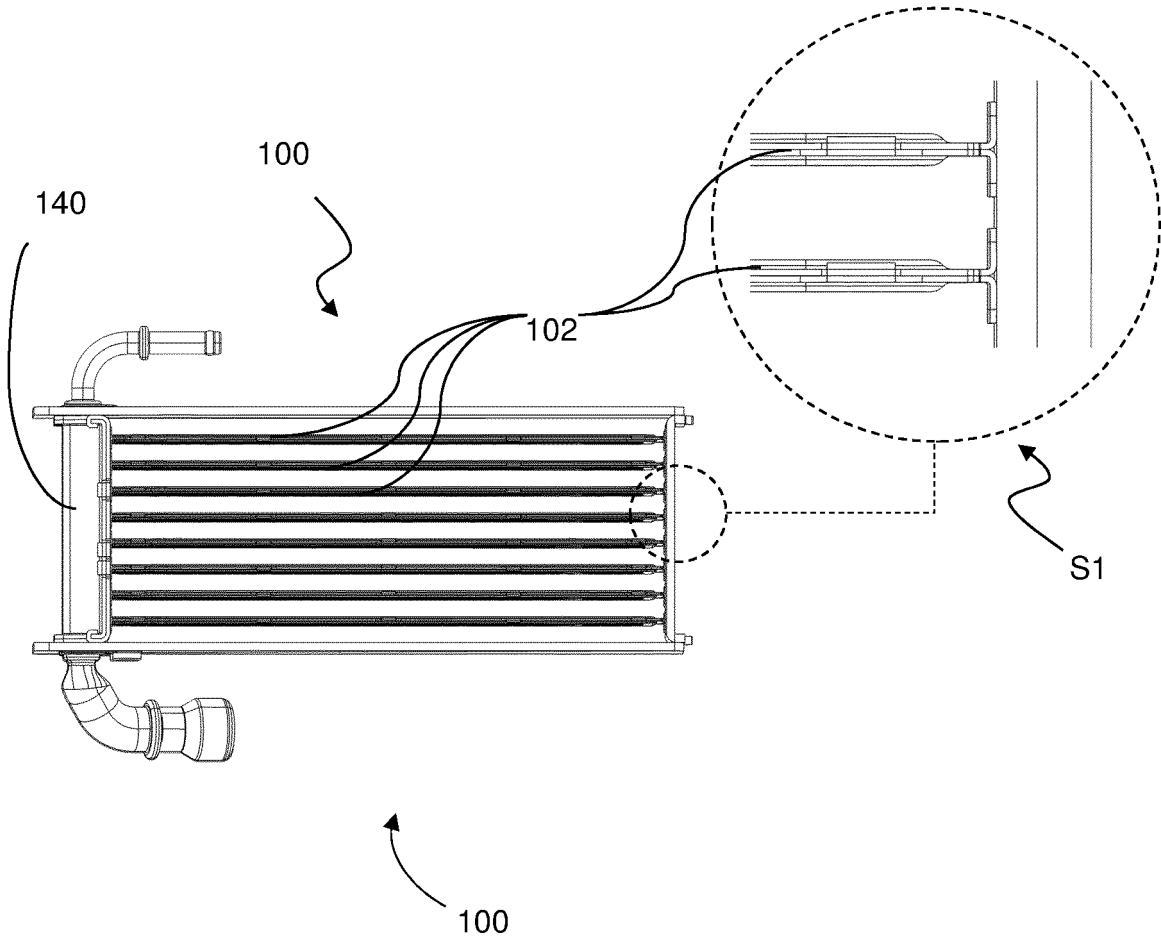

Fig. 2 (Prior art.)

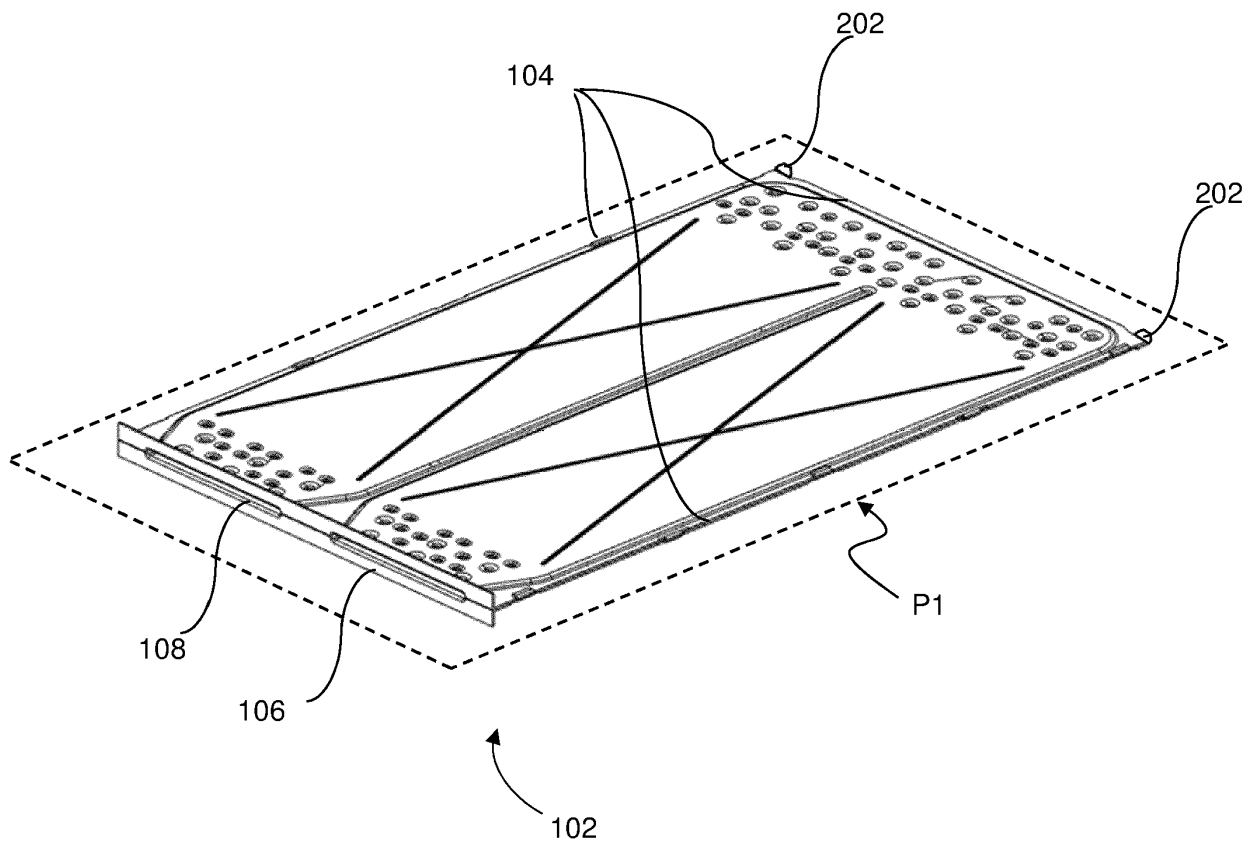
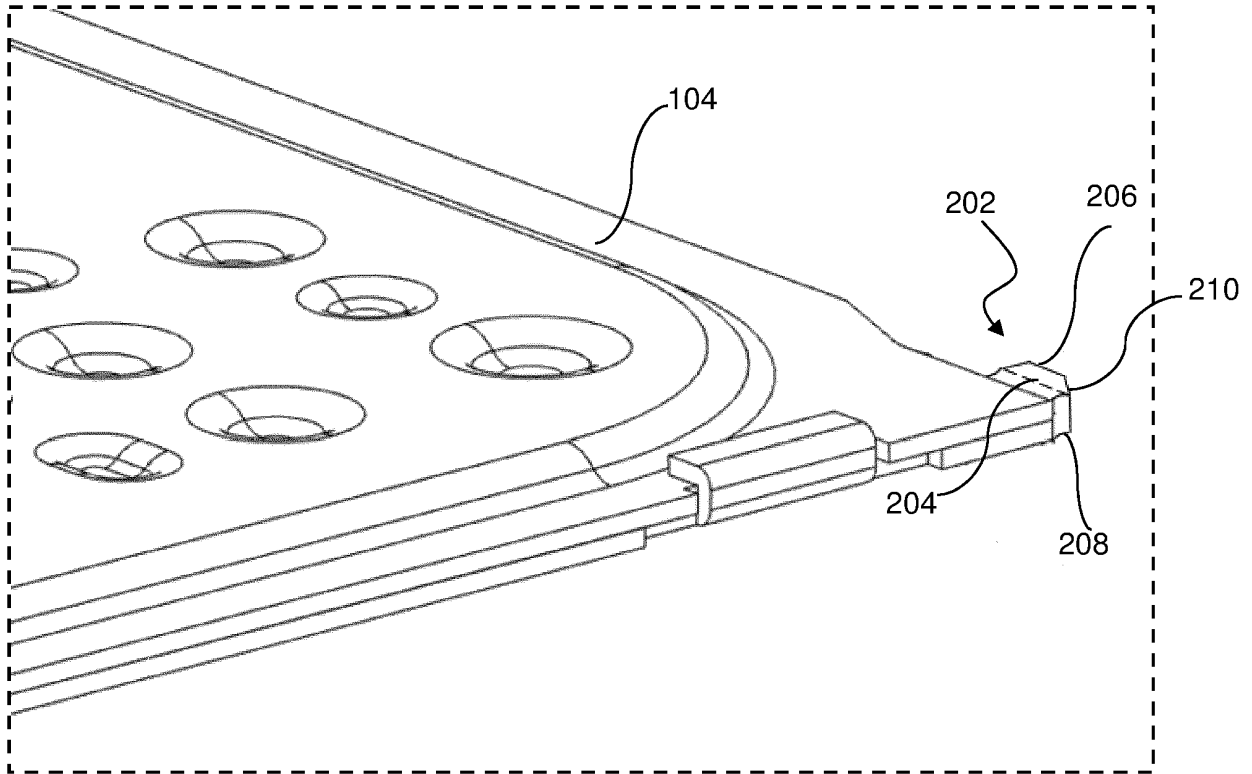

Fig. 3



102

Fig. 4

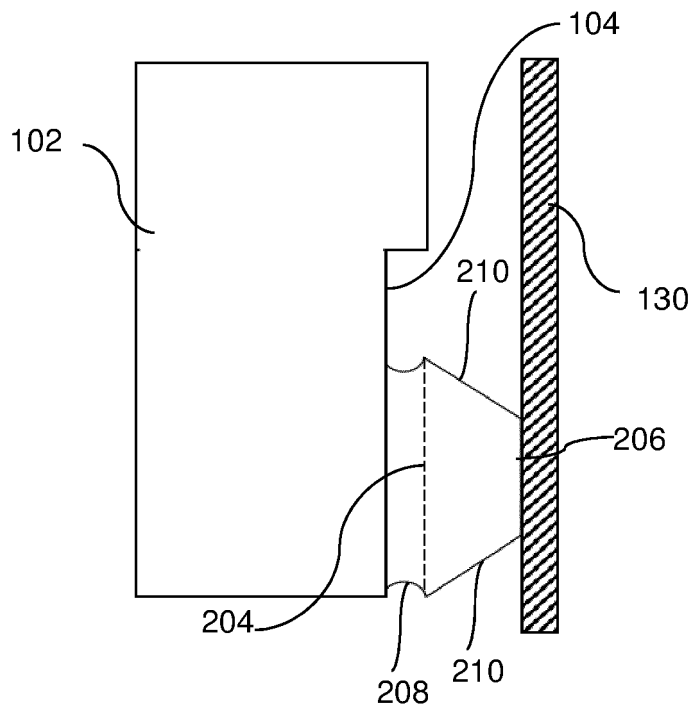

Fig. 5

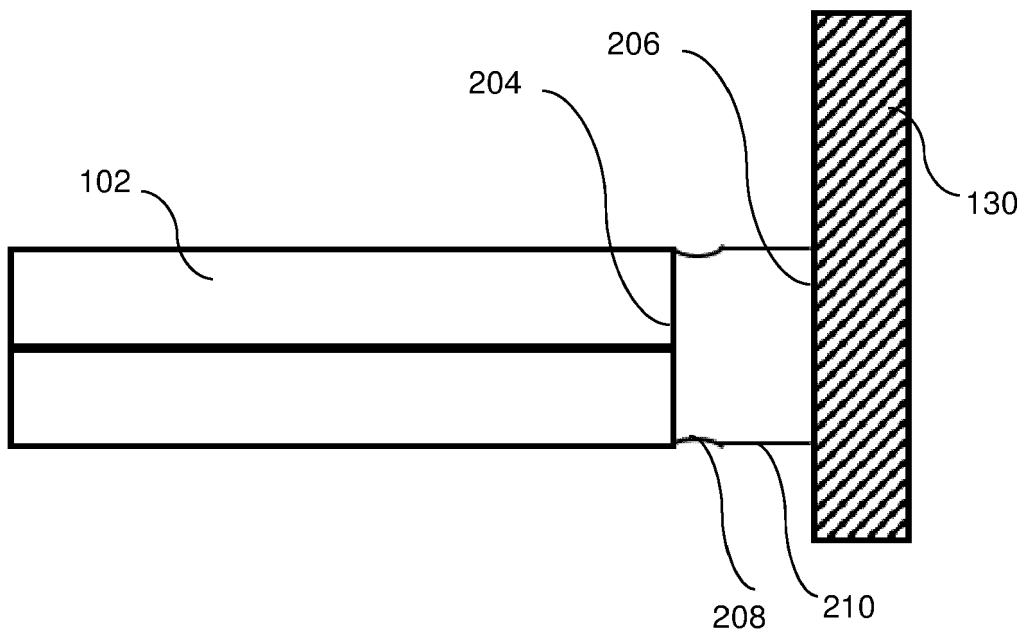

Fig. 6

REFERENCES CITED IN THE DESCRIPTION

This list of references cited by the applicant is for the reader's convenience only. It does not form part of the European patent document. Even though great care has been taken in compiling the references, errors or omissions cannot be excluded and the EPO disclaims all liability in this regard.

Patent documents cited in the description

- WO 2016049776 A [0001]