

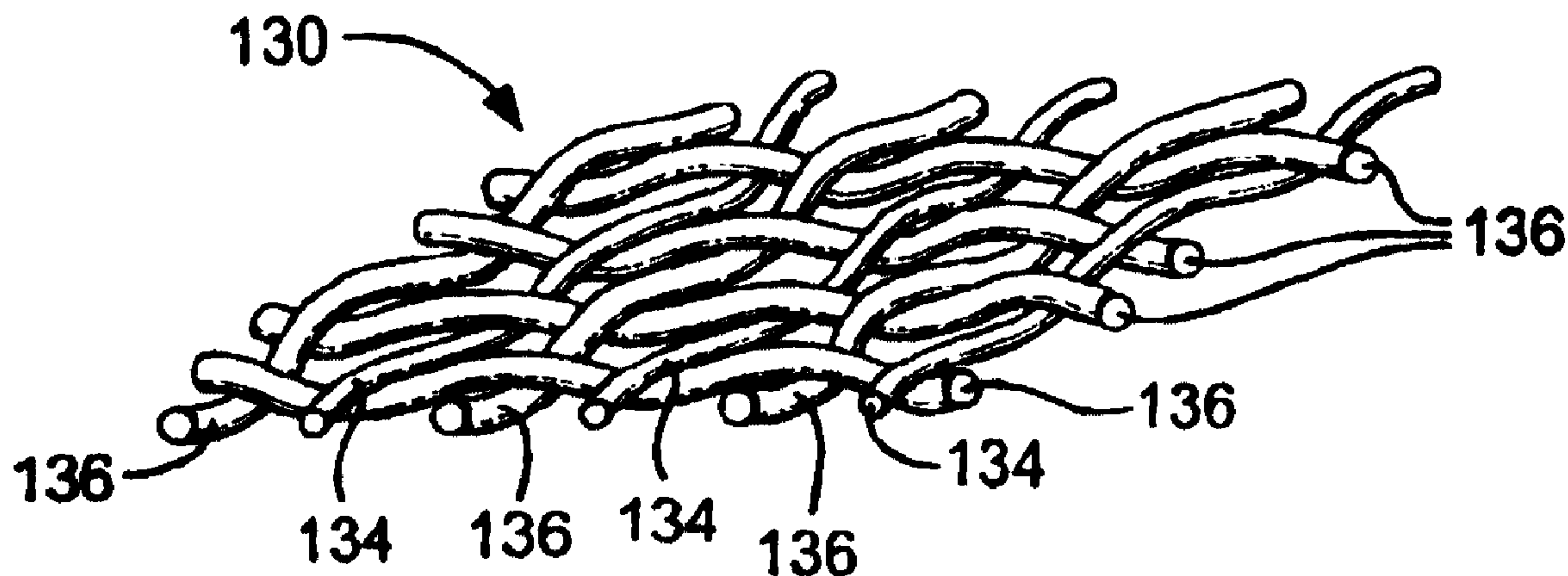

(22) Date de dépôt/Filing Date: 2000/11/03
 (41) Mise à la disp. pub./Open to Public Insp.: 2001/05/10
 (45) Date de délivrance/Issue Date: 2006/07/04
 (62) Demande originale/Original Application: 2 382 677
 (30) Priorité/Priority: 1999/11/03 (US09/432,959)

(51) Cl.Int./Int.Cl. *B07B 1/46* (2006.01),
B07B 1/40 (2006.01), *B01D 39/10* (2006.01)
 (72) Inventeur/Inventor:
 SCHULTE, DAVID LEE, US
 (73) Propriétaire/Owner:
 VARCO I/P, INC., US
 (74) Agent: MCFADDEN, FINCHAM

(54) Titre : CRIBLE, DISPOSITIF DE CRIBLE ET SYSTEME DE CRIBLE VIBRANT
 (54) Title: A SCREEN, A SCREEN ARRANGEMENT AND A SCREEN VIBRATORY SYSTEM



(57) **Abrégé/Abstract:**

A screen for a vibratory separator for screening fluid with material entrained therein introduced on the screen, the screen having, in certain aspects, a plurality of warp wires and a plurality of shute wires, the warp wires interwoven with the shute wires, the plurality of warp wires including a plurality of first warp wires and a plurality of spaced-apart support wires, the support wires having a diameter greater than a diameter of the warp wires. In another aspect, a screen for a vibratory separator for screening fluid with material entrained therein introduced on the screen, the screen having a plurality of warp wires and a plurality of shute wires, the warp wires interwoven with the shute wires, the plurality of shute wires including a plurality of first shute wires and a plurality of spaced-apart support wires, the support wires having a diameter greater than a diameter of the first shute wires. The invention is also directed to a screen arrangement comprising at least two of said screens on top of each other, and to a screen vibratory system comprising screen vibrating apparatus and a screen of the invention.

ABSTRACT**A SCREEN, A SCREEN ARRANGEMENT AND A SCREEN VIBRATORY
SYSTEM**

5 A screen for a vibratory separator for screening fluid
with material entrained therein introduced on the screen,
the screen having, in certain aspects, a plurality of warp
wires and a plurality of shute wires, the warp wires
interwoven with the shute wires, the plurality of warp
10 wires including a plurality of first warp wires and a
plurality of spaced-apart support wires, the support wires
having a diameter greater than a diameter of the warp
wires. In another aspect, a screen for a vibratory
separator for screening fluid with material entrained
15 therein introduced on the screen, the screen having a
plurality of warp wires and a plurality of shute wires, the
warp wires interwoven with the shute wires, the plurality
of shute wires including a plurality of first shute wires
and a plurality of spaced-apart support wires, the support
20 wires having a diameter greater than a diameter of the
first shute wires.

The invention is also directed to a screen arrangement
comprising at least two of said screens on top of each
other, and to a screen vibratory system comprising screen
25 vibrating apparatus and a screen of the invention.

- 1 -

**A SCREEN, A SCREEN ARRANGEMENT AND A SCREEN VIBRATORY
SYSTEM**

This application is a divisional of Canadian Patent
5 Application No. 2,382,677, filed November 3, 2000.

This invention relates to a screen, a screen
arrangement and a screen vibratory system.

Various woven cloth screens for vibratory separators
are used in removing particles from a liquid and are
10 designed to provide a tortuous path for the liquid. Many
prior art woven cloths, including the typical weave, twill,
dutch weave or twill dutch weave cloths have low fluid
conductance characteristics due to the formation of the
tortuous flow path. A minimal rate of flow results in a
15 correspondingly slow filtering process. Often the screens
need frequent cleaning to maintain a desired flow rate.

Certain prior art screens provide an open surface area
and permit direct or nontortuous flow through the screen.
Such screens may provide better conductance
20 characteristics, but the fluid conductance may be limited
by the permissible ratio of length to width in the
interstices between the screen filaments and the fineness
of the filaments. With increasing spacing between
filaments, deformation of the filaments from the parallel
25 may increase and larger than desired particles can then
pass through the screen. To maintain an efficient
relationship, the size of the rectangular interstices in
these screens is generally minimal and the length to width
ratio is generally less than three unless coarse, stiff
30 filaments are used. Higher ratios can be achieved by
bonding together the crossing filaments of the screen; but
bonding can be a complex and costly process with negative
side effects. By coating the filaments with a bonding
material, the diameter of the filaments is increased,

- 2 -

further reducing fluid conductance of the screen.

Particle separation, fluid throughput or conductance and screen life are important characteristics of screens for vibratory separators. Finer particle separation
5 results in a higher percentage of impurities being removed from the screened fluid. Higher conductances are desirable because more fluid can be processed per square foot of screen area, thereby reducing costs. Doubling conductance doubles the liquid throughput. Longer screen life saves
10 time and money. Since the mid-seventies one vibrating screen industry trend has been to decrease wire diameter in order to achieve higher conductance. For certain prior art screens this means finer separation and higher conductance but shorter screen life. To increase screen life, the
15 industry has tried various types of bonded screens such as plastic-backed, metal-backed or bonded-backup. These bonded screens are relatively expensive. U.S. Patents 5,370,797; 5,256,291; and 5,256,292 disclose double shute or warp screens with a double warp plain weave screen
20 having warp and shute wires of the same material and properties, the shute diameter at least 1.4 times the warp diameter to prevent sleaziness. If the shute diameter controls the conductance and if the shute diameter is fine enough to give very high conductance, the warp diameter is
25 so fine that the screen has a low tensile strength and therefore shorter life; and screens for removing undesirable particles from a liquid in which a substantially flat parallel array of shute filaments are spaced at less than a preselected minimal linear dimension
30 of undesirable particles and a parallel array of groups of warp filaments runs transverse to the shute filaments. The warp filaments of each group are oppositely woven about and between the shute filaments taken individually or in pairs to secure the shute filaments and maintain the spaces

- 3 -

therebetween. The groups of shute filaments have spaces therebetween smaller than the preselected minimal linear dimension of the undesirable particles so that the screen is characterized by elongated rectangular flow apertures therethrough. Each group includes from 3 to 10 or more warp filaments and the shute filament diameters are as small as in the order of 1.1 times the warp filament diameter. Conductance is increased by making the rectangular apertures longer. The life of the screen is increased by increasing the number of warp wires to achieve the required tensile strength. Finer particle separation is achieved by making the short dimension of the rectangle smaller. Screens formed by this weaving of groups of three or more warp filaments transverse to shute filaments which are as small as in the order of 1.1 times the diameter of the warp filaments provide meshes having relatively higher aspect ratios with smaller filament diameters than with certain known weaves of filaments of this range of diameter.

It has been found that it is advantageous to have a screen with relatively fine diameter wires, but with desirable throughput, conductance, and non-clogging, non-blinding characteristics. It has been found that sufficient support is required for relatively finer mesh screens and that the screens are durable in their intended uses.

According to the present invention, there is provided a screen for a vibratory separator, the screen comprising a plurality of warp wires, a plurality of shute wires, the warp wires interwoven with the shute wires, characterised in that, said warp wires comprises a plurality of first warp wires and a plurality of spaced-apart undulating support wires, the undulating support wires having a diameter greater than a diameter of the first warp wires.

35

According to the present invention, there is provided a screen arrangement comprising at least two screens as above, one on top of the other. Preferably, the at least two screens are bonded together.

According to the invention, there is also provided a screen arrangement comprising a plurality of at least two screens, one on top of the other said plurality comprising at least a first screen and a second screen; the first screen comprising a plurality of first warp wires and a plurality of first shute wires, the first warp wires interwoven with the first shute wires, and a plurality of spaced-apart first support wires having a diameter greater than a diameter of the first warp wires.

The second screen comprises a plurality of second warp wires and a plurality of second shute wires, the second warp wires interwoven with the second shute wires, and a plurality of second spaced-apart support wires interwoven with the second shute wires, the second support wires having a diameter greater than a diameter of the second warp wires; and the first support wires having a diameter less than the diameter of the second support wires.

Preferably, the at least two screens are bonded together, and the diameter of the first support wires is at least 1.15 times greater than the diameter of the first warp wires.

It is also desirable in the first screen every other wire in the warp direction is a first support wire, in the first screen every third wire in the warp direction is a first support wire, and there is further comprising a lower support below the plurality of at least two screens.

The present invention preferably is provided with a frame to which is connected the plurality of at least two screens, the diameter of the second support wires is at least 1.15 times greater than the diameter of the second

warp wires, in the second screen every other wire in the shute direction is a second support wire, and in the second screen every third wire in the shute direction is a second support wire. Furthermore, it is desirable the wires are made from material from the group consisting of metal, steel, stainless steel, copper, bronze, brass, aluminum, aluminum alloy, zinc, zinc alloy, platinum, titanium, plastic, fibreglass, and polytetrafluoroethylene.

According to the present invention there is provided a vibratory separator system for treating fluid introduced thereto, the fluid having material entrained therein, the system comprising:

- a vibratory separator;

- a plurality of at least two screens on the vibratory separator for screening material from the fluid, the plurality of at least two screens comprising at least a first screen and a second screen;

- the first screen comprising a plurality of first warp wires and a plurality of first shute wires, the first warp wires interwoven with the first shute wires and a plurality of spaced-apart first support wires interwoven with the first shute wires, the first support wires having a diameter greater than a diameter of the first warp wires;

- the second screen comprising a plurality of second warp wires and a plurality of second shute wires, the second warp wires interwoven with the second shute wires, and a plurality of second spaced-apart support wires interwoven with the second shute wires, the second support wires having a diameter greater than a diameter of the second warp wires; and

- the first support wires having a diameter less than the diameter of the second support wires.

BRIEF DESCRIPTION OF THE DRAWINGS

Fig. 1A is a perspective view of a prior art screen;

Fig. 1B is a cross-section view of the screen of Fig. 1A;

5 Fig. 2A is a top view, partially cut away of a prior art screen;

Fig. 2B is a cross-section view of the screen of Fig. 2A;

Fig. 3A is a cross-section view of a prior art screen;

10 Fig. 3B is a cross-section view of a prior art screen;

Fig. 4A is a top view of a screen according to the present invention;

Fig. 4B is a cross-section view of the screen of Fig. 4A;

15 Fig. 5A is a top view of a screen according to the present invention;

Fig. 5B is a cross-section view of the screen of Fig. 5A.

20 Fig. 6A is a top view of a screen according to the present invention;

Fig. 6B is a cross-section view of the screen of Fig. 6A;

Fig. 7 is a perspective view of a screen according to the present invention;

25 Fig. 8 is a top view of a screen according to the present invention;

Fig. 9 - 13 are top views of screens according to the present invention;

30 Fig. 14 is a cross-section view of a screen according to the present invention;

- 7 -

Fig. 15 is a cross-section view of a screen according to the present invention;

Fig. 16 is a cross-section view of a screen according to the present invention;

5 Fig. 17A is a top plan view of a screen according to the present invention;

Fig. 17B is a side view of the screen of Fig. 17A; and

Fig. 18 is a perspective view of a shale shaker with a screen according to the present invention.

10

DETAILED DESCRIPTION OF THE INVENTION

Having thus generally described the present invention reference will now be made to the accompanying drawings illustrating preferred embodiments of the invention.

15 Figs. 1A and 1B show a prior art screen 22 as disclosed in U.S. Patent 2,723,032 with a coarse mesh wire screen, or cloth 23 that provides a backing screen or cloth of the unit. A fine mesh wire screen 24 is superimposed or mounted upon the backing screen 23. The screen unit 22 has
20 its coarse backing wire mesh or cloth coated or covered preferably with rubber or some suitable rubber or synthetic rubber composition. The strands are indicated at 25 and the covering or coating at 26. Since all of the strands 23 are coated or covered, there is, of course, rubber-to-
25 rubber contact between these strands of the coarser mesh screen 23. The backing screen of cloth 23 is of the roller flat-top type and of any coarse size such, for example, as three or four mesh. The mesh of the finer mesh wire screen 24 varies, in accordance with the separating job to be
30 done. For example, the mesh of the fine wire screen or cloth 24 may vary from the order of minus 20 (-20) to the order of minus 325 (-325).

Figs. 2A and 2B disclose a screen 30 as disclosed in U.S. Patent 4,696,751 with a first mesh screen with

- 8 -

rectangular dimensions of width and length. A second screen 38 is held in superimposed abutting relationship to the first screen 32. The second 38 has width and length dimensions. The length dimensions of the first screen is
5 larger than length dimension of the second screen, and the width dimension of the first screen is smaller than the width dimension of the second screen.

Figs. 3A and 3B disclose screens 50 and 53 shown in U.S. Patent 5,626,234 which has an upper cloth 51 and lower
10 cloth 52. The upper cloth 51 is formed from woven stainless steel wire in the range 0.19 mm to 0.036 mm diameter and 60 - 325 mesh, (i.e. number of strands per inch) while the lower cloth 52 is formed from woven phosphor bronze wire in the range 0.45 mm to 0.19 mm
15 diameter and 20 - 40 mesh. A screen 53 in Fig. 3B has an upper cloth 54 like the upper cloth 51 (Fig. 3A) and a lower cloth 55 woven from stainless steel wire having a nominal diameter in the range 0.20 to 0.45 mm diameter and typical 30 mesh, and is coated with an epoxy based
20 material, or Molybdenum Disulphide, or Teflon (Registered Trade Mark), to a thickness in the range 5 to 50 microns typically 20 to 40 microns. Multiple passes of the wire through a coating process or through a succession of such processes may be necessary to achieve the desired coating
25 thickness. The wires 57, 58, 59 are shown in cross section to show the outer material coatings 67, 68, 69 (not to scale). The wire 64 is shown with the coating scraped from one end.

Fig. 4A shows a screen 100 according to the present
30 invention for use in a vibratory separator, e.g., but not limited to, a shale shaker. The screen has a square mesh pattern with a plurality of wires 102 in one direction (shute direction) each of substantially the same cross-sectional diameter, e.g. ranging between about 0.032cm

- 9 -

(0.0126 inches) and about 0.00254cm (0.0010 inches). The screen has a plurality of wires 104 in a direction orthogonal to that of the wires 102. The wires 104 have a cross-sectional diameter similar to that of the wires 102. Spaced-apart by the wires 104 and by space therebetween is a plurality of support wires 106 with a cross-sectional diameter larger than that of the wires 104. In certain embodiments the diameter of the wires 106 ranges between about 0.032cm (0.0126 inches) and about 0.00254cm (0.0010 inches). In certain aspects the diameter of the wires 106 is at least 1.15 times larger than the diameter of the wires 104.

A screen 110 shown in Figs. 5A and 5B is like the screen 100, but the larger diameter wires 106 are every third wire in the warp direction, rather than every other wire as in the screen 100. Also every third wire 108 in the shute direction is a larger diameter wire like the wires 106. The same numerals in Figs. 4A and 5A indicate the same parts.

Fig. 6A shows a screen 120 according to the present invention with a twill mesh pattern with every third wire 126 (like the wires 106, Fig. 4A) in both directions of a larger diameter than the remaining wires 122 and 124 (like the wires 102, 104 respectively, Fig. 4A).

Fig. 7 shows a screen 130 with all larger diameter wires 136 (like the wires 106, Fig. 4A) in the shute direction and every other wire in the warp direction of larger diameter. Every other wire 134 in the warp direction is a smaller diameter wire (like the wires 102, 104, Fig. 4A).

Fig. 8 shows a screen 140 according to the present invention with a rectangular mesh pattern with every other wire in the warp direction a larger diameter wire 146 (like the wires 106, Fig. 4A) and smaller diameter wires 142 and

- 10 -

144 (like the wires 102, 104 respectively, Fig. 4A).

Fig. 9 - 13 show screens 150, 151, 153, 155, and 157 respectively, each with a rectangular mesh pattern, with larger diameter wires 156 (like the wires 106, Fig. 4A) and smaller diameter wires 152, 154 (like the wires 102, 104 respectively, Fig. 4A).

Fig. 14 shows a screen 160 according to the present invention like the screen of U.S. Patent 2,723,032, but with alternating larger diameter wires 25a instead of the wires 25 as shown in Figs. 1A - 1B. The coating 26a is larger than the coating 26 shown in Fig. 1B. It is also within the scope of this invention for the upper screen layer of the screen 22 to be of any screen material according to the present invention.

Fig. 15 shows a screen 170 according to the present invention like the screen of U.S. Patent 4,696,751 (Figs. 2A and 2B), but with larger diameter wires 176 (every other wire) between the wires 179 [in the layer 44 (Figs. 2A, 2B)] and with every fourth wires 178 in the top layer of screen material larger in cross-sectional diameter than the remaining wires 177 in that layer. The wires 176 may be eliminated; the layer 44 may be eliminated; and/or the wires 178 may be eliminated - all according to the present invention. It is also within the scope of the present invention to use any screening material disclosed herein for any of the fine screening layers of the screen 170.

Fig. 16 shows a screen 180, like the screen of U.S. Patent 5,626,234 shown in Fig. 3A, but with larger diameter wires 186 in the lower screening layer between smaller diameter wires 187 and larger diameter wires 188 in the upper screening layer between smaller diameter wires 189. Either plurality of larger diameter wires may be eliminated and the lower layer of screening material may be eliminated.

35

- 11 -

Figs. 17A and 17B show a screen 190 according to the present invention with an optional outer frame 191 (like any frame disclosed in the prior art) with screening material 192 mounted thereto (like any screening material according to the present invention disclosed herein). Item 5 193 shown schematically in Fig. 17B indicates any known lower supporting apertured plate, perforated plate, series of straps or strips, strip member or coarse supporting mesh, which is optional for the screen 190. It is within 10 the scope of this invention to have additional layers of screening material (one, two or more) according to the present invention above or below the layer of screening material 192. Any screen 190 with two or more layers of screening material may have the layers interconnected, 15 bonded to each other, and/or sintered together in any known manner. Any known hookstrip (e.g. angled, L-shaped, C-shaped, etc.) may be used with the screen 190 and with any screen according to the present invention.

Fig. 18 shows a vibratory separator system 200 20 according to the present invention that has a screen 202 (like any screen disclosed herein) according to the present invention mounted on vibratable screen mounting apparatus or "basket" 204. The screen 202 may be any screen disclosed herein or have any combination of any feature or 25 features of any screen or screen part disclosed herein; and any such screen may be used with any appropriate shaker or screening apparatus. The basket 204 is mounted on springs 206 (only two shown; two as shown are on the opposite side) which are supported from a frame 208. The basket 204 is 30 vibrated by a motor 203 and interconnected vibrating apparatus 209 which is mounted on the basket 204 for vibrating the basket and the screens. Elevator apparatus 205 provides for raising and lowering of the basket end.

- 12 -

The present invention, therefore, in certain (and not necessarily all) embodiments, provides a screen for a vibratory separator (e.g. but not limited to a shale shaker) for screening fluid with material entrained therein introduced on the screen, the screen having a plurality of warp wires, a plurality of shute wires, the warp wires interwoven with the shute wires, the plurality of warp wires including a plurality of first warp wires and a plurality of spaced-apart support wires, the support wires having a diameter greater than a diameter of the warp wires. Such a screen may have one, or some (in any possible combination) of the following: wherein the diameter of the support wires is at least 1.15 times greater than the diameter of the first warp wires; wherein the diameter of the support wires ranges between 0.032cm (0.0126 inches) and 0.00254cm (0.0010 inches); wherein every other wire in the warp direction is a support wire; wherein every third wire in the warp direction is a support wire; wherein the wires are woven together in a square mesh pattern; wherein the wires are woven together in a twill mesh pattern; a lower support below the screen; and/or an outer frame around and to which is connected the screen.

The present invention, therefore, in certain (and not necessarily all) embodiments, provides a screen for a vibratory separator for screening fluid with material entrained therein introduced on the screen, the screen having a plurality of warp wires, a plurality of shute wires, the warp wires interwoven with the shute wires, the plurality of shute wires including a plurality of first shute wires and a plurality of spaced-apart support wires, the support wires having a diameter greater than a diameter of the first shute wires. Such a screen may have one, or some (in any possible combination) of the following: wherein the diameter of the support wires is at least 1.15

- 13 -

times greater than the diameter of the first shute wires;
wherein the diameter of the support wires ranges between
0.032 (0.0126 inches) and 0.00254cm (0.0010 inches);
wherein every other wire in the shute direction is a
5 support wire; wherein every third wire in the shute
direction is a support wire; wherein the wires are woven
together in a square mesh pattern; wherein the wires are
woven together in a twill mesh pattern; a lower support
below the screen; an outer frame around and to which is
10 connected the screen; and/or wherein the warp wires and
shute wires are made from material from the group
consisting of metal, steel, stainless steel, copper,
bronze, brass, aluminum, aluminum alloy, zinc, zinc alloy,
platinum, titanium, plastic, fiberglass, and
15 polytetrafluoroethylene.

The present invention, in certain aspects, discloses a
screen with wires of varying diameter in a single screen
cloth layer. In one aspect, alternate wires (e.g. but not
limited to, every other wire, every third wire, every
20 fourth wire, or every fifth wire) in a screen warp
direction are of a larger diameter than the other wires of
the screen. In other aspects, alternate wires (e.g. but
not limited to, every other wire, every third wire, every
fourth wire, or every fifth wire) in a screen shute
25 direction are of a larger diameter than the other wires of
the screen. Alternatively, all wires in a warp direction
or in a shute direction may be of the larger diameter.

- 14 -

CLAIMS:

1. A plurality of at least two screens, one on top of the other, said plurality comprising at least a first screen and a second screen;

the first screen comprising a plurality of first warp wires and a plurality of first shute wires, the first warp wires interwoven with the first shute wires, and a plurality of spaced-apart first support wires interwoven with the first shute wires, the first support wires having a diameter greater than a diameter of the first warp wires;

the second screen comprising a plurality of second warp wires and a plurality of second shute wires, the second warp wires interwoven with the second shute wires, and a plurality of second spaced-apart support wires interwoven with the second shute wires, the second support wires having a diameter greater than a diameter of the second warp wires; and

the first support wires having a diameter less than the diameter of the second support wires.

2. The plurality of at least two screens of claim 1, wherein the at least two screens are bonded together.

3. The plurality of at least two screens of claim 1 or 2, wherein the diameter of the first support wires is at least 1.15 times greater than the diameter of the first warp wires.

4. The plurality of at least two screens of any one of claims 1, 2 or 3, wherein in the first screen every other wire in the warp direction is a first support wire.

5. The plurality of at least two screens of any one of

- 15 -

claims 1, 2 or 3, wherein in the first screen every third wire in the warp direction is a first support wire.

6. The plurality of at least two screens of any one of claims 1 to 5, further comprising a lower support below the plurality of at least two screens.

7. The plurality of at least two screens of any one of claims 1 to 6, with frame to which is connected the plurality of at least two screens.

8. The plurality of at least two screens of any one of claims 1 to 7, wherein the diameter of the second support wires is at least 1.15 times greater than the diameter of the second warp wires.

9. The plurality of at least two screens of any one of claims 1 to 8, wherein in the second screen every other wire in the shute direction is a second support wire.

10. The plurality of at least two screens of any one of claims 1 to 8, wherein in the second screen every third wire in the shute direction is a second support wire.

11. The plurality of at least two screens of any one of claims 1 to 10, wherein the wires are made from material from the group consisting of metal, steel, stainless steel, copper, bronze, brass, aluminum, aluminum alloy, zinc, zinc alloy, platinum, titanium, plastic, fibreglass, and polytetrafluoroethylene.

12. A vibratory separator system for treating fluid introduced thereto, the fluid having material entrained therein, the system comprising:

- 16 -

a vibratory separator;

a plurality of at least two screens on the vibratory separator for screening material from the fluid, the plurality of at least two screens comprising at least a first screen and a second screen;

the first screen comprising a plurality of first warp wires and a plurality of first shute wires, the first warp wires interwoven with the first shute wires and a plurality of spaced-apart first support wires interwoven with the first shute wires, the first support wires having a diameter greater than a diameter of the first warp wires;

the second screen comprising a plurality of second warp wires and a plurality of second shute wires, the second warp wires interwoven with the second shute wires, and a plurality of second spaced-apart support wires interwoven with the second shute wires, the second support wires having a diameter greater than a diameter of the second warp wires; and

the first support wires having a diameter less than the diameter of the second support wires.

1/7

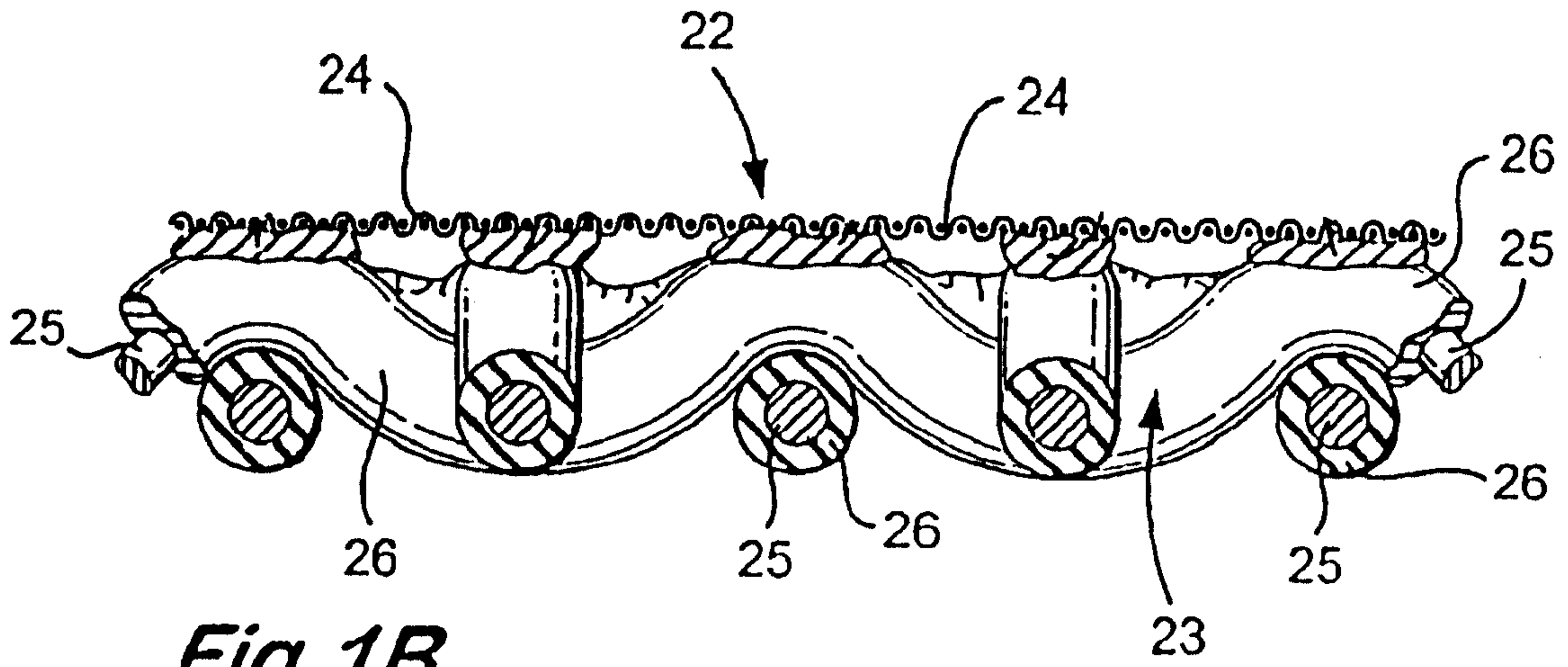
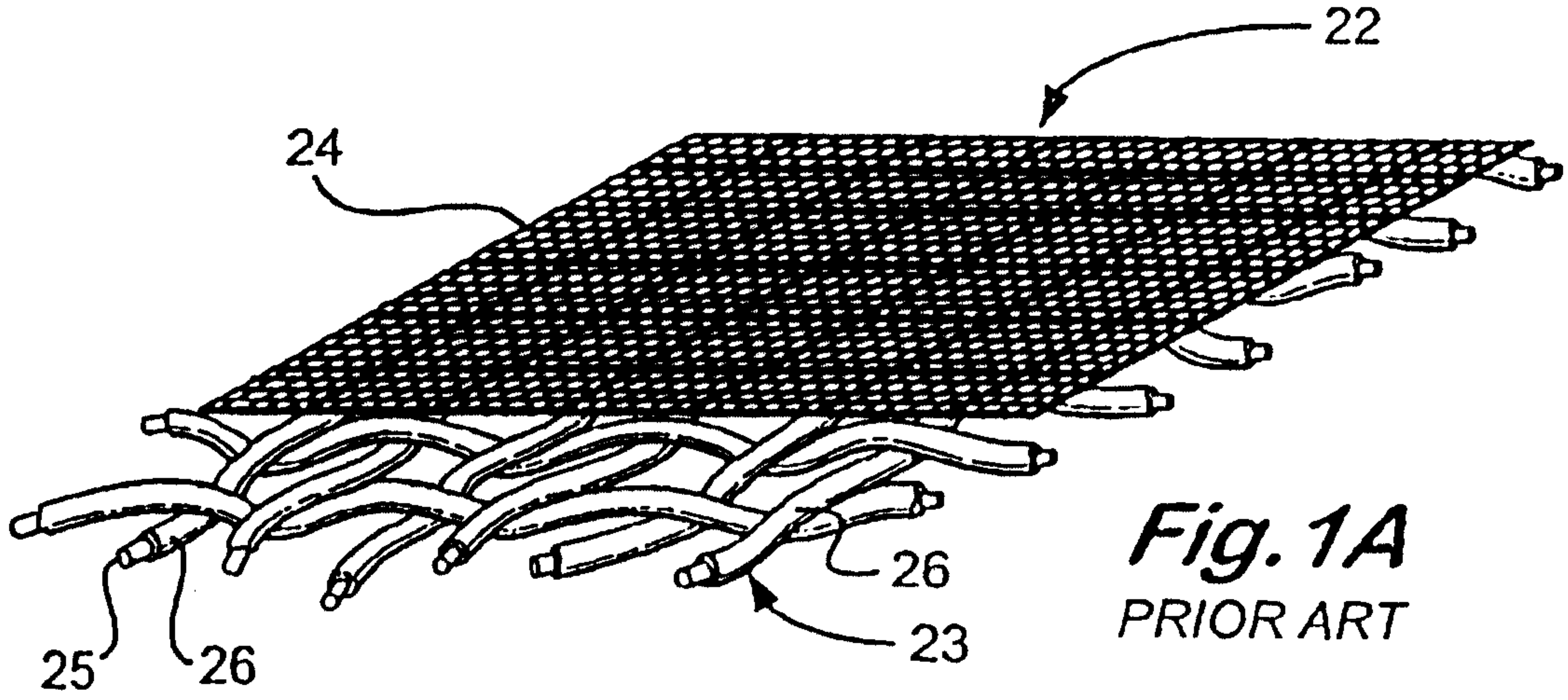

Fig. 1B
PRIOR ART

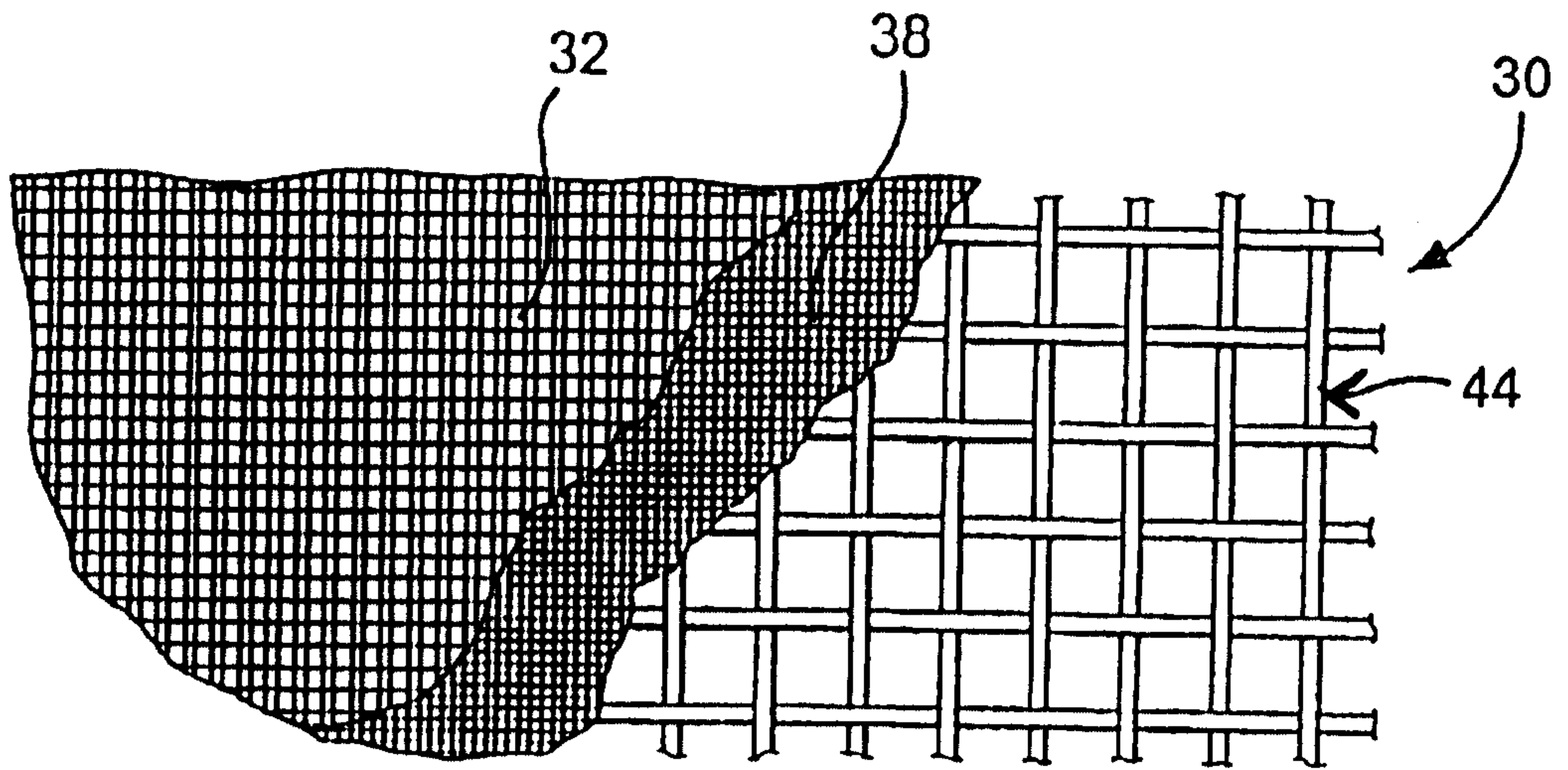
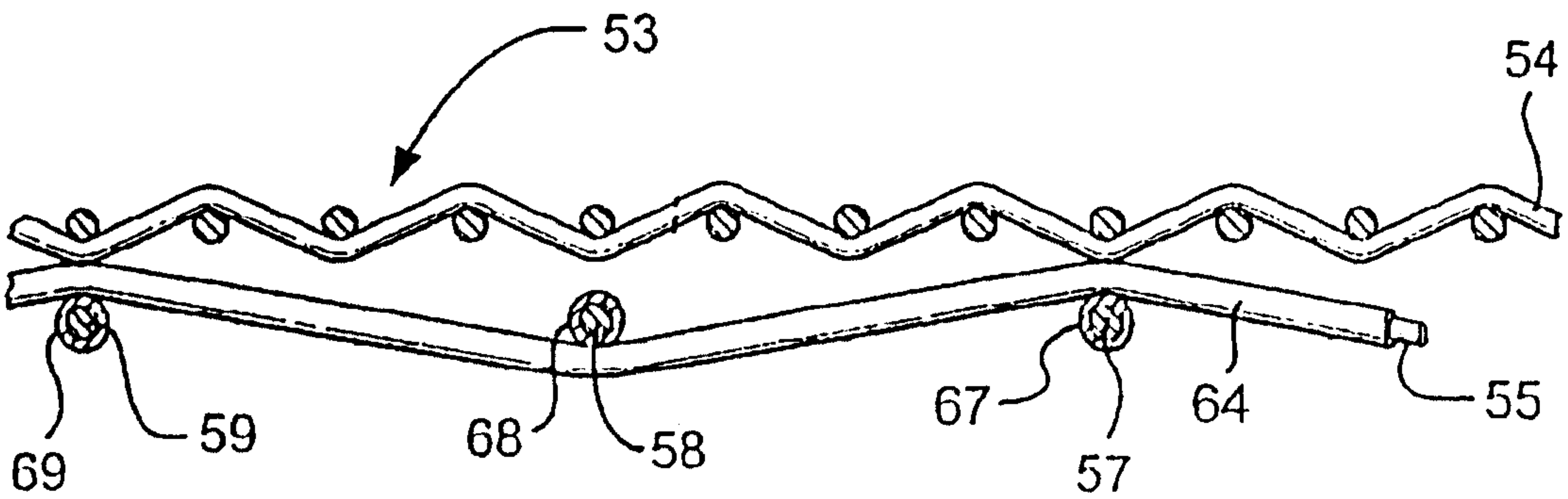
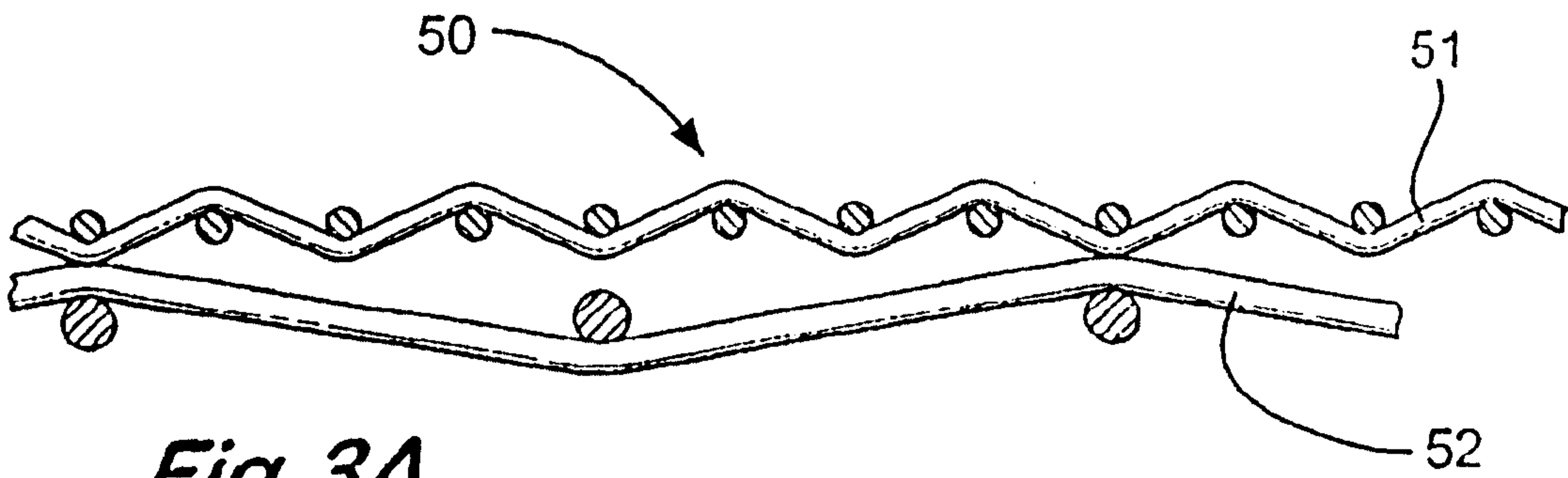
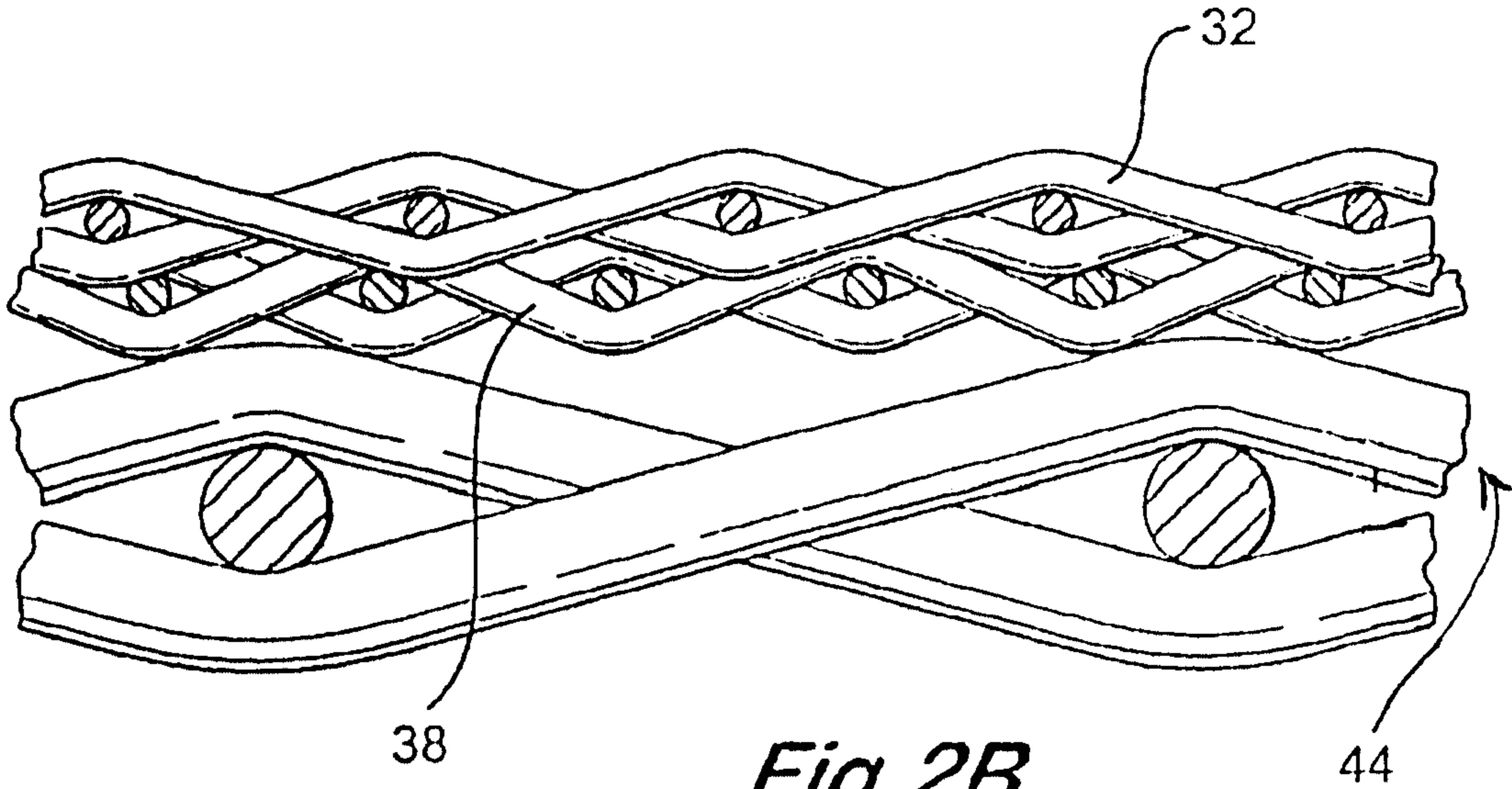
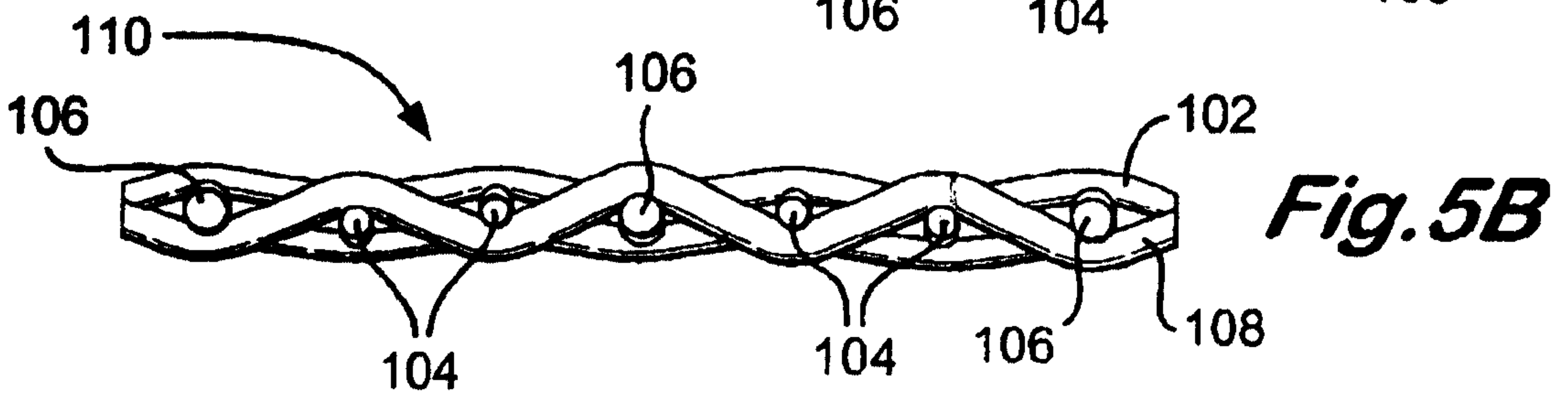
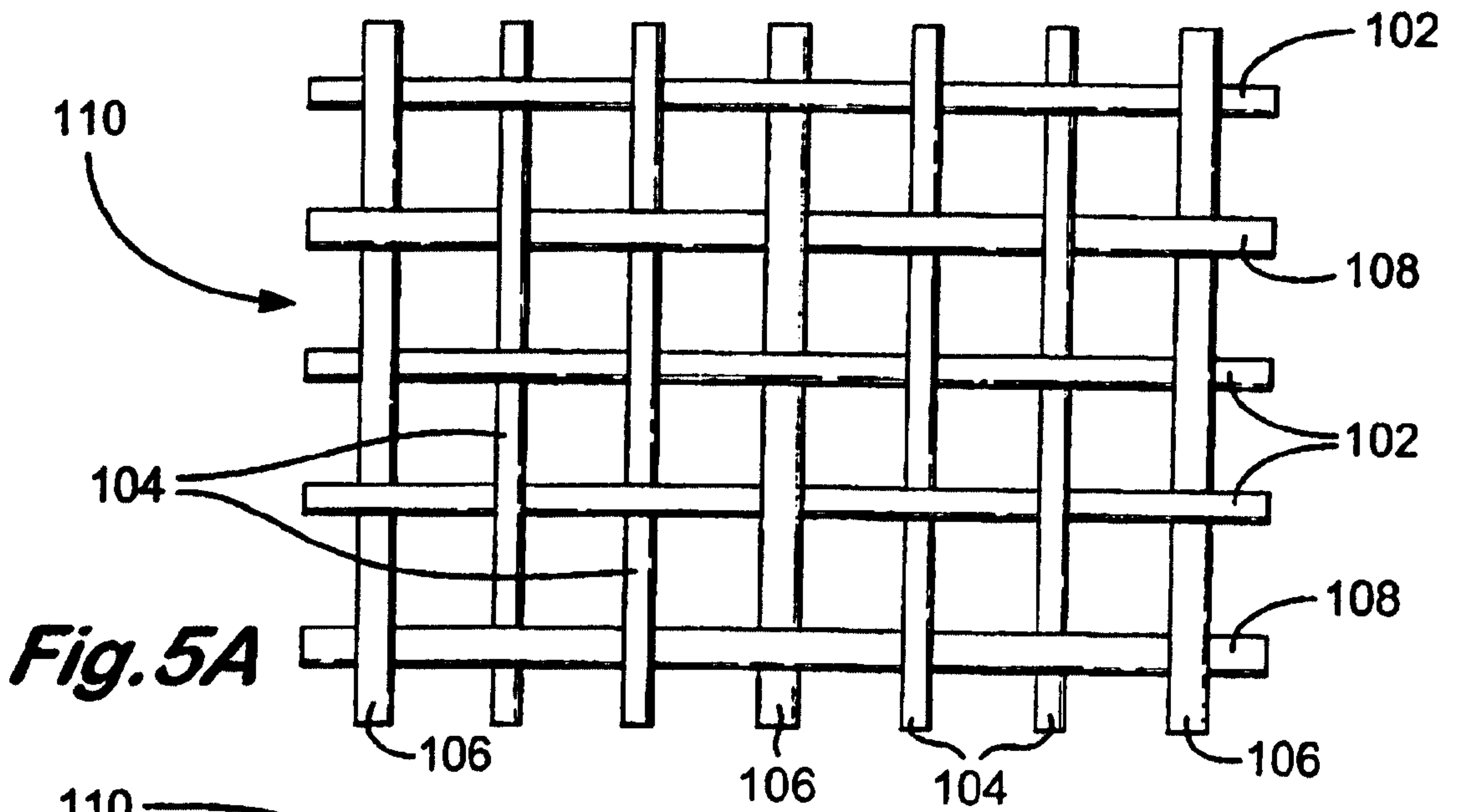
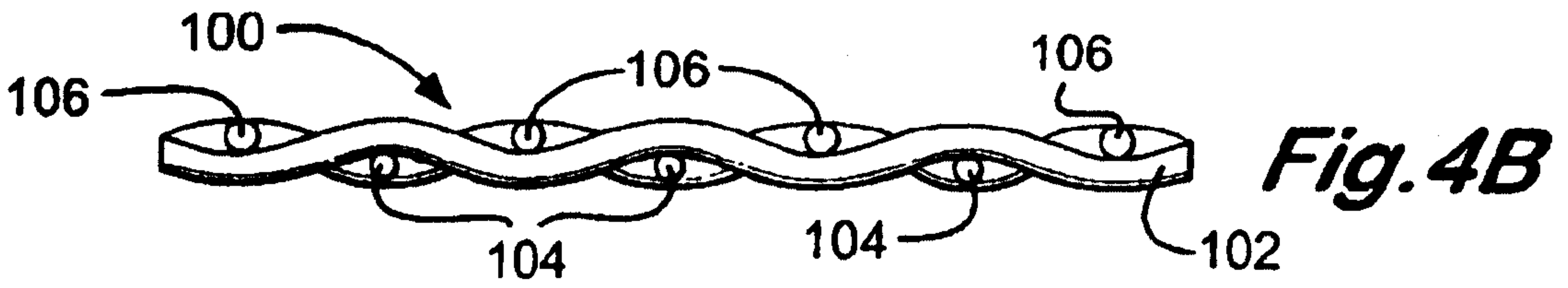
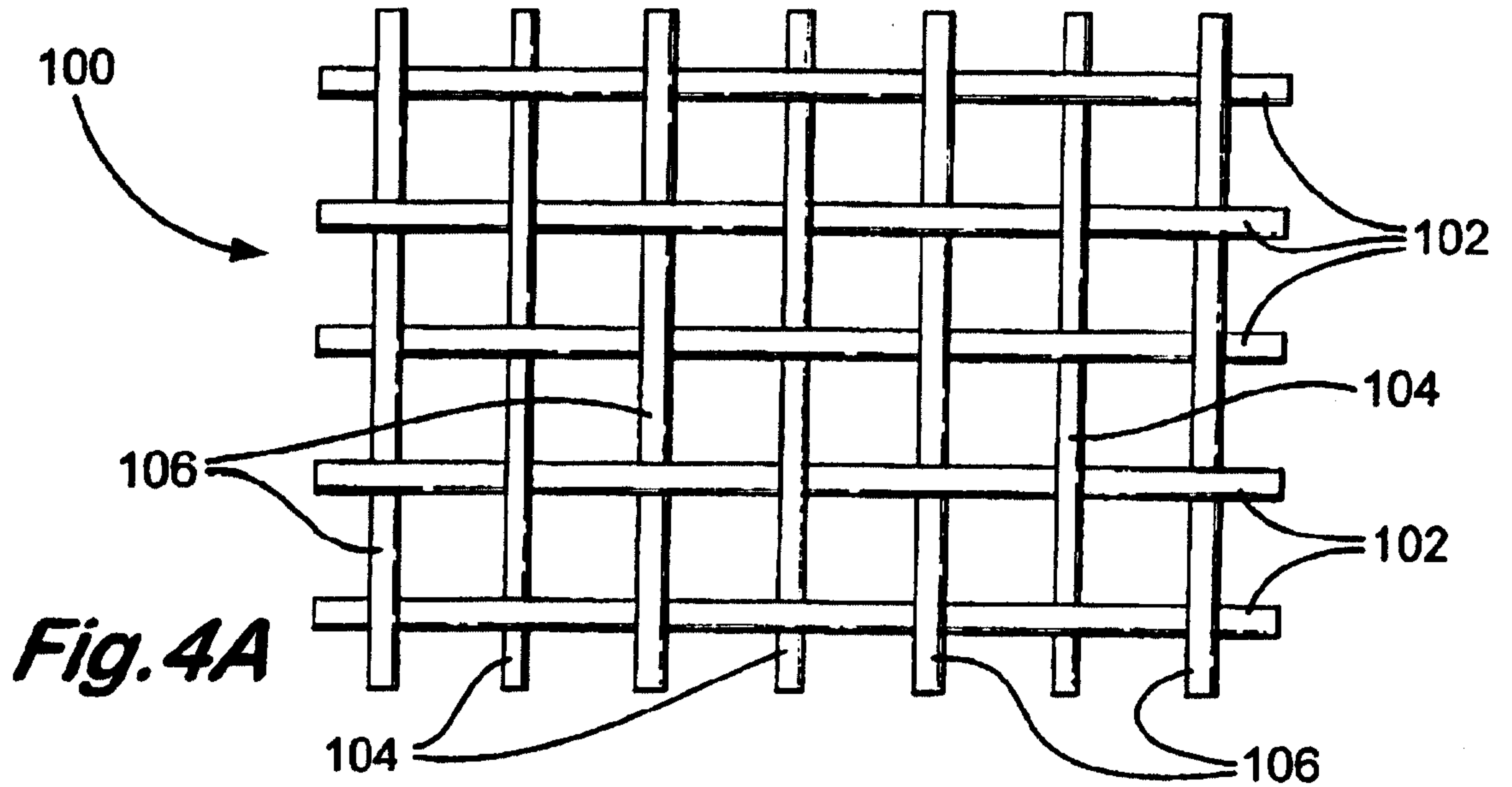
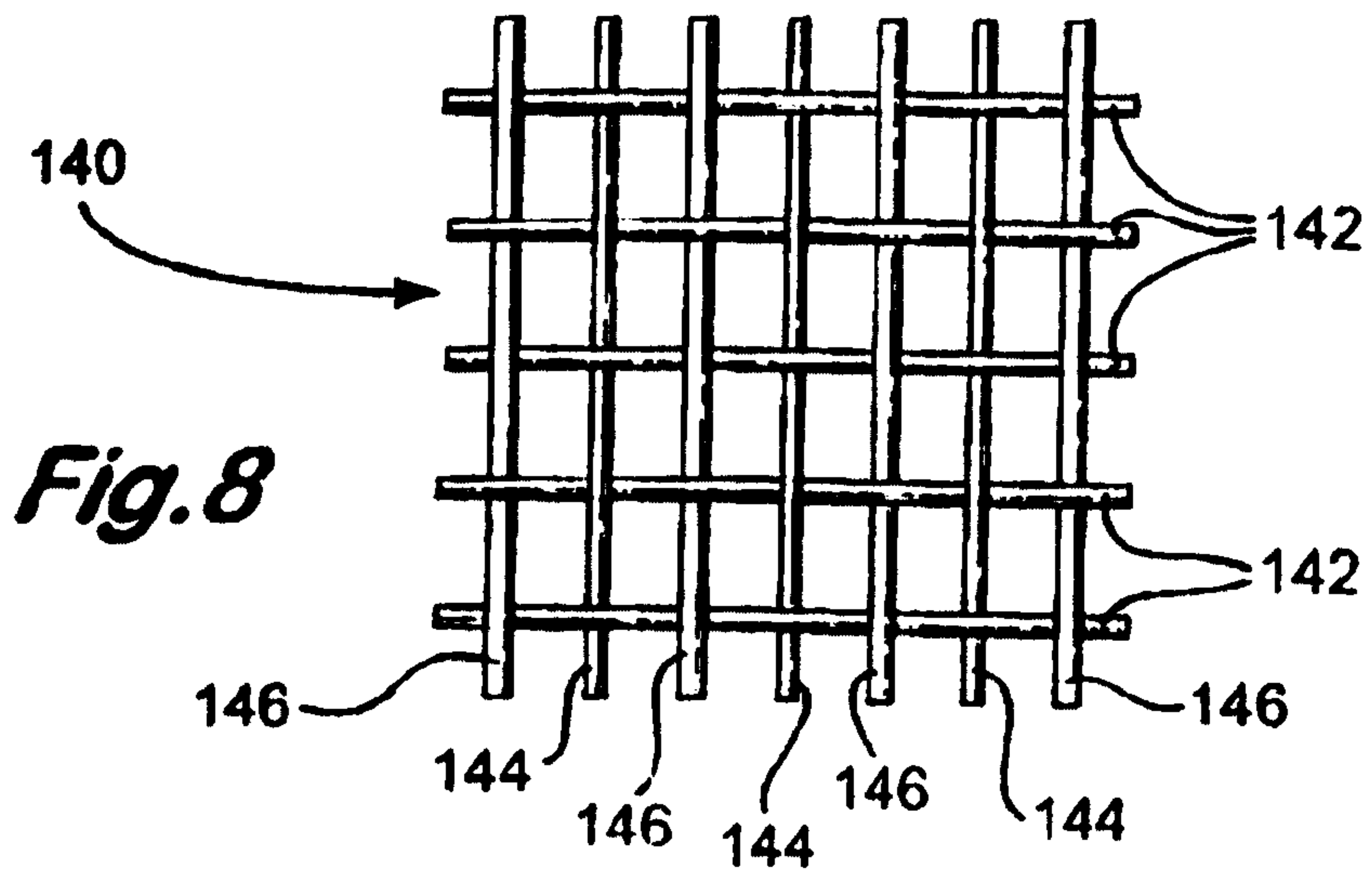
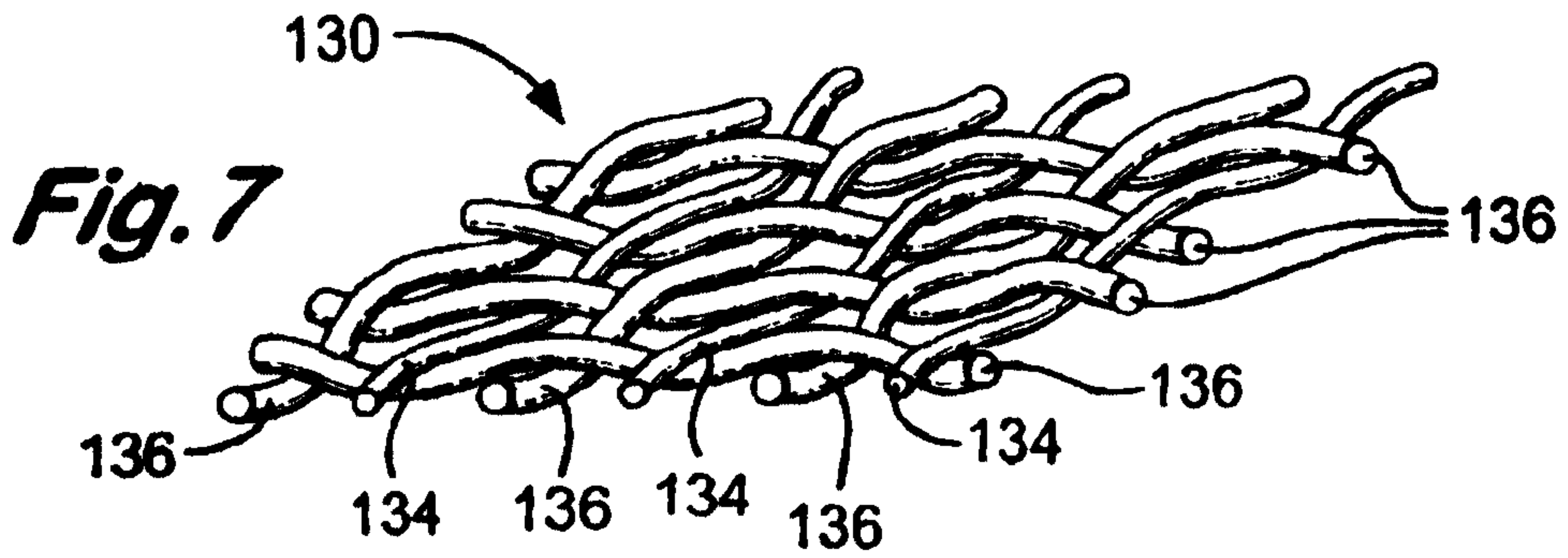
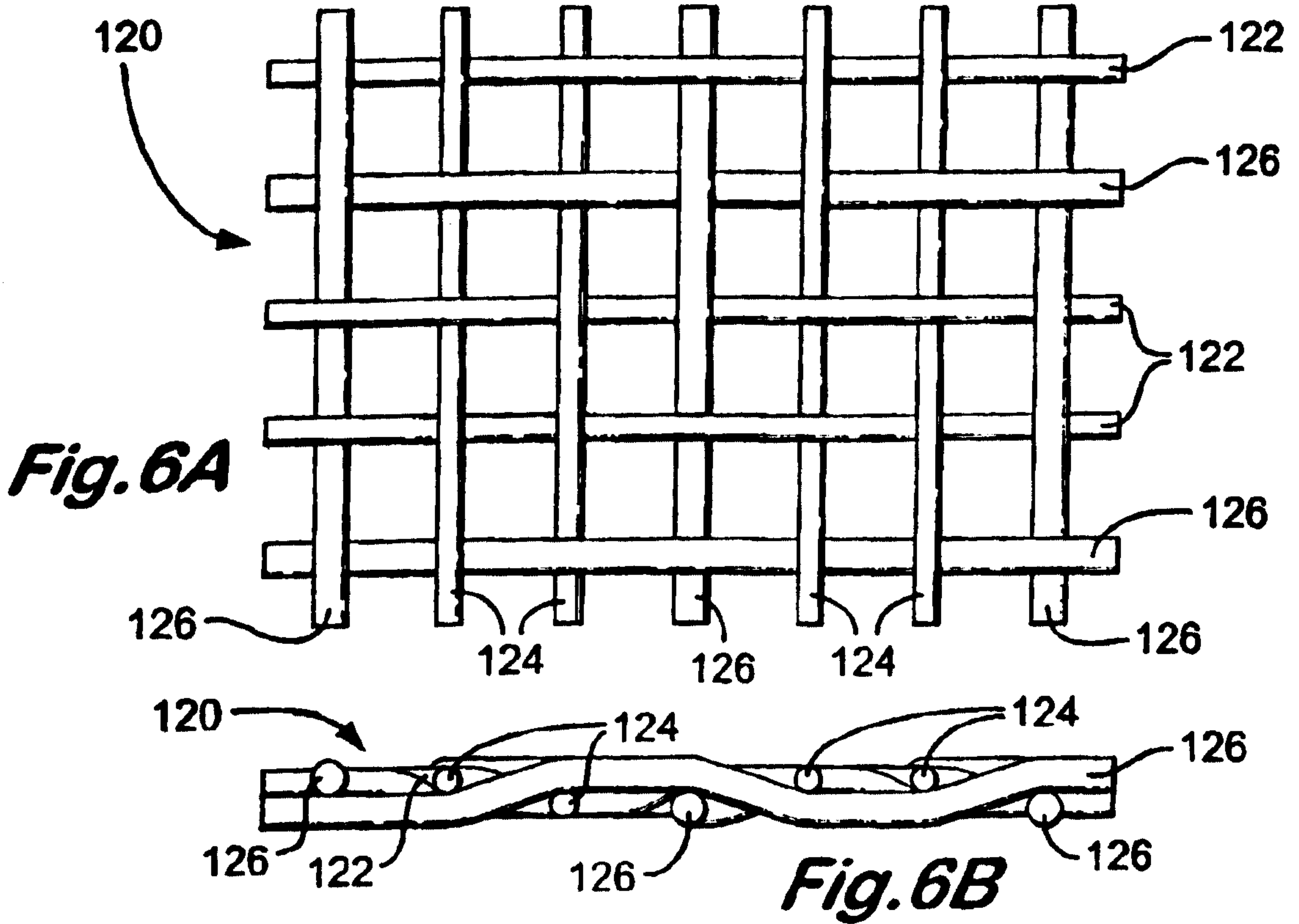

Fig. 2A
PRIOR ART





4/7



5/7

Fig. 9

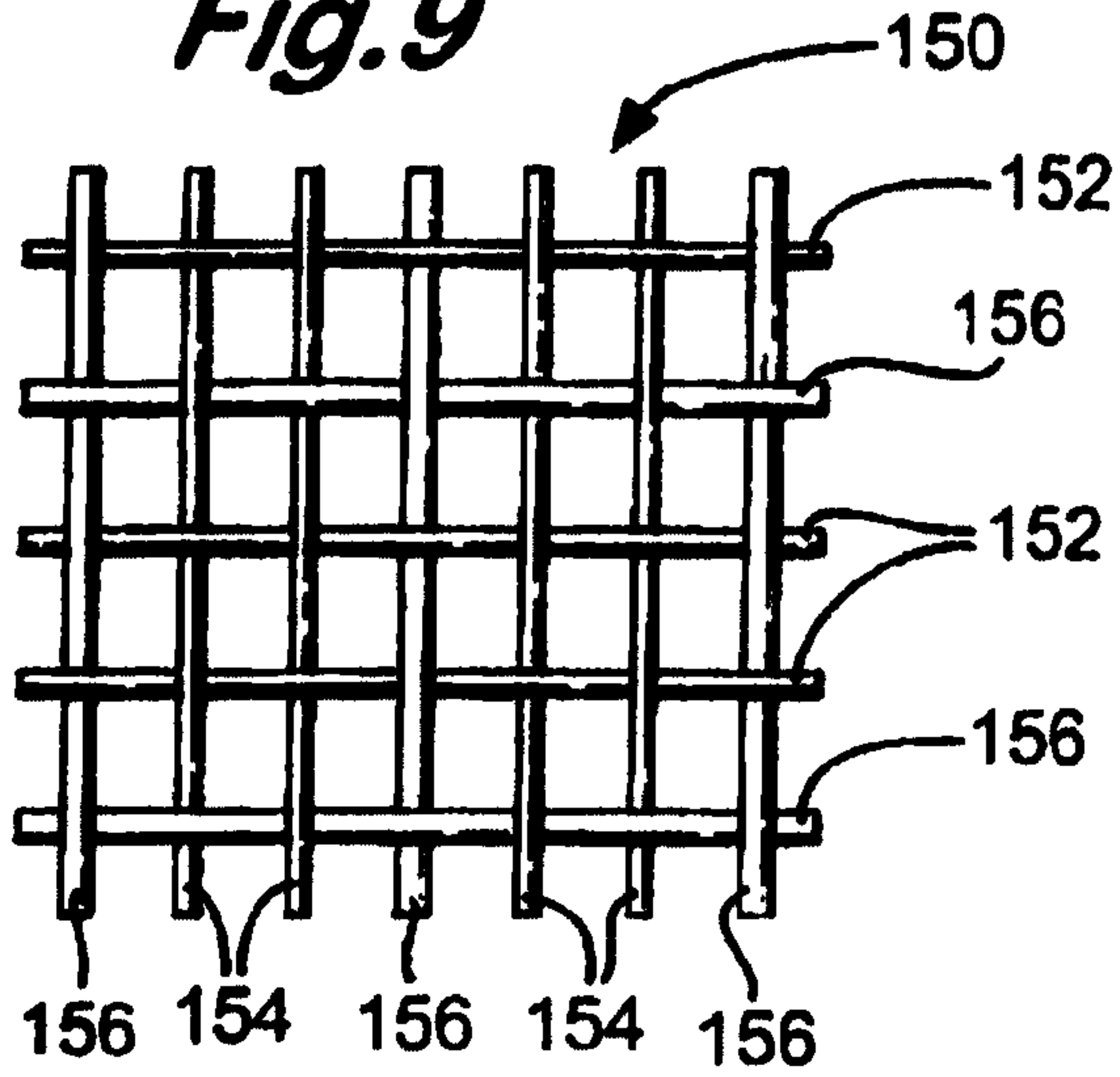

Fig. 10

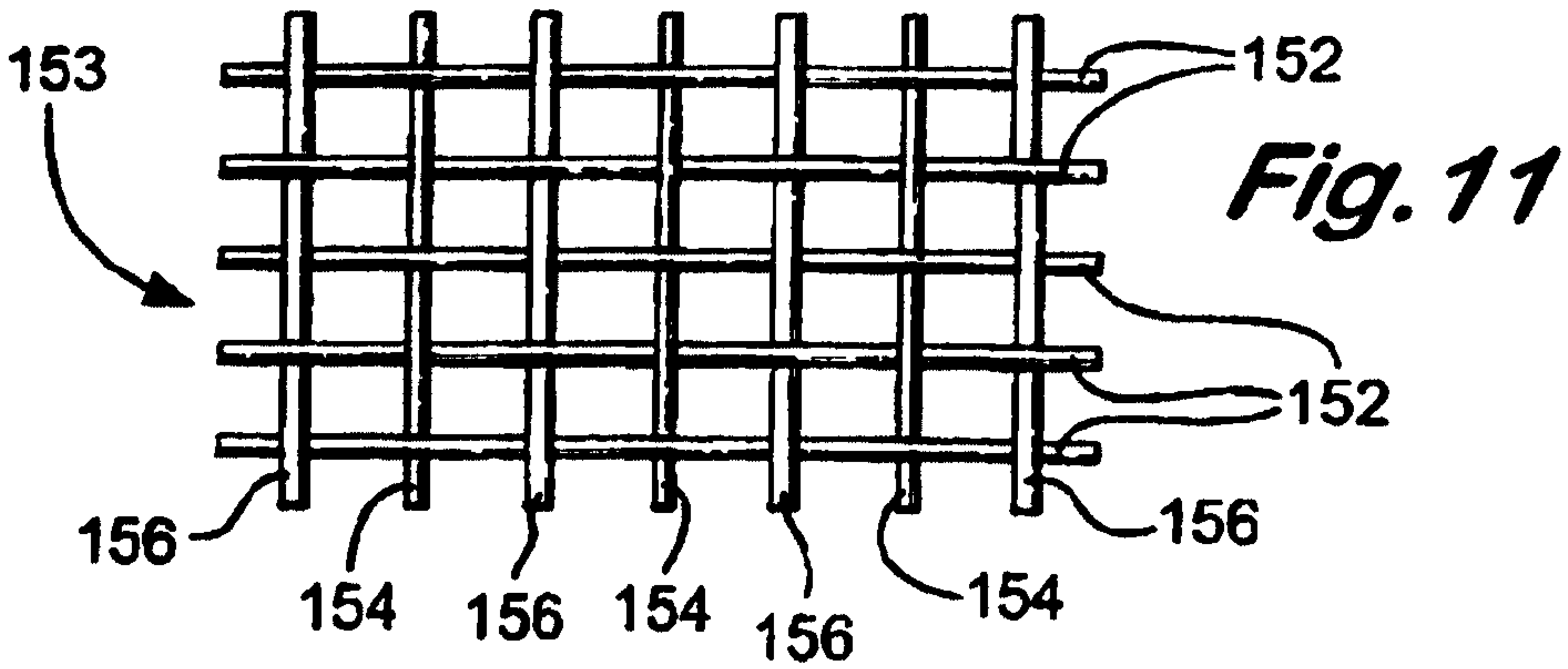
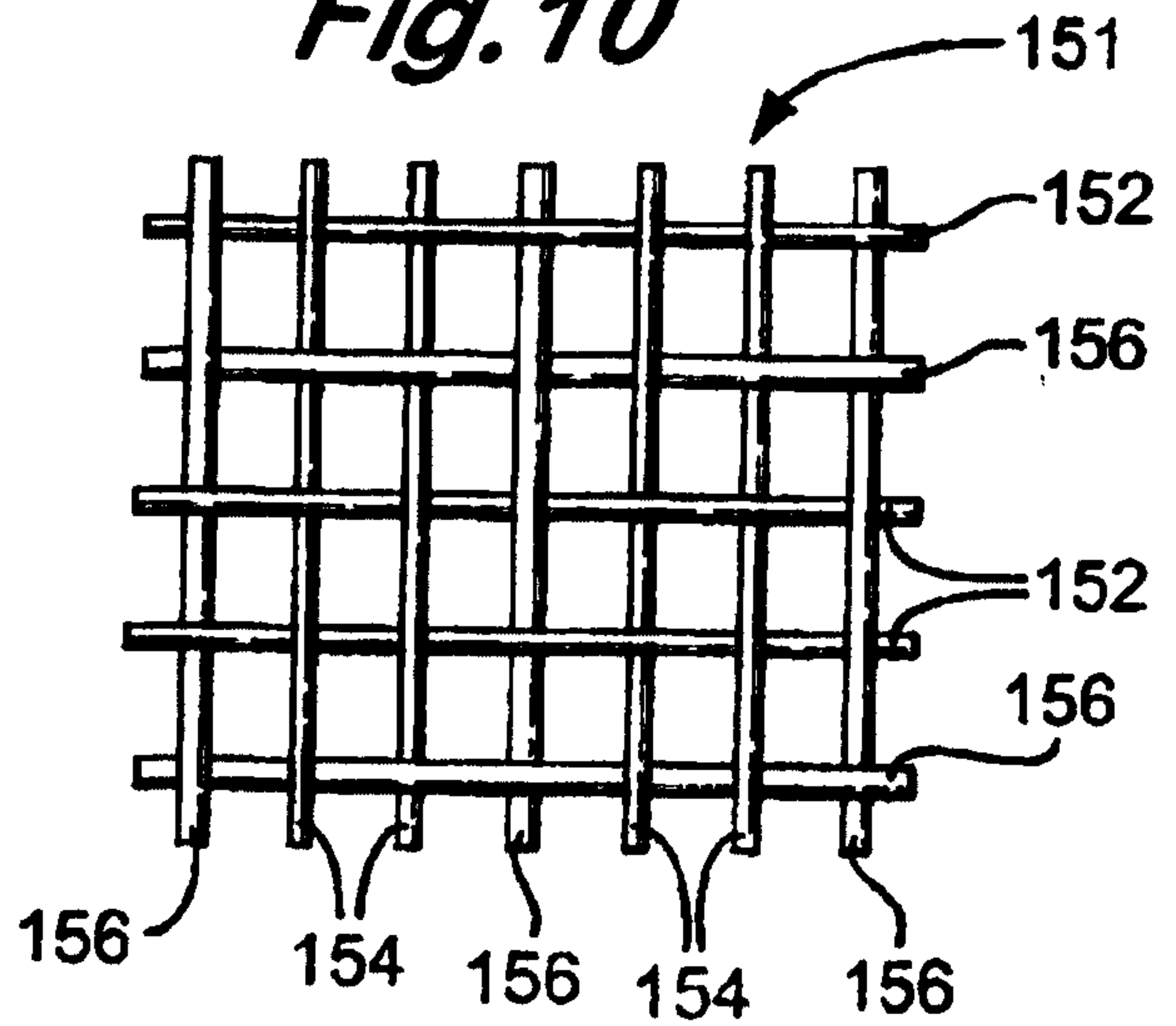
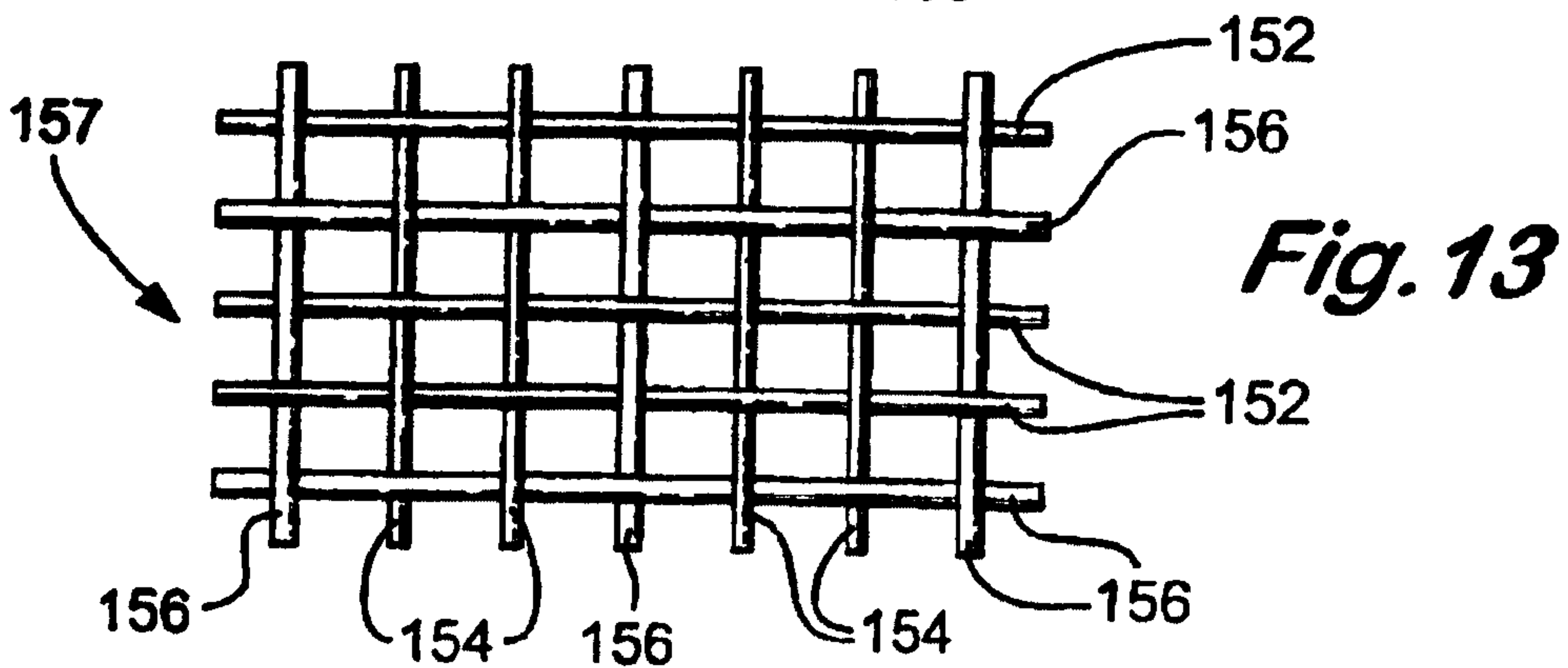
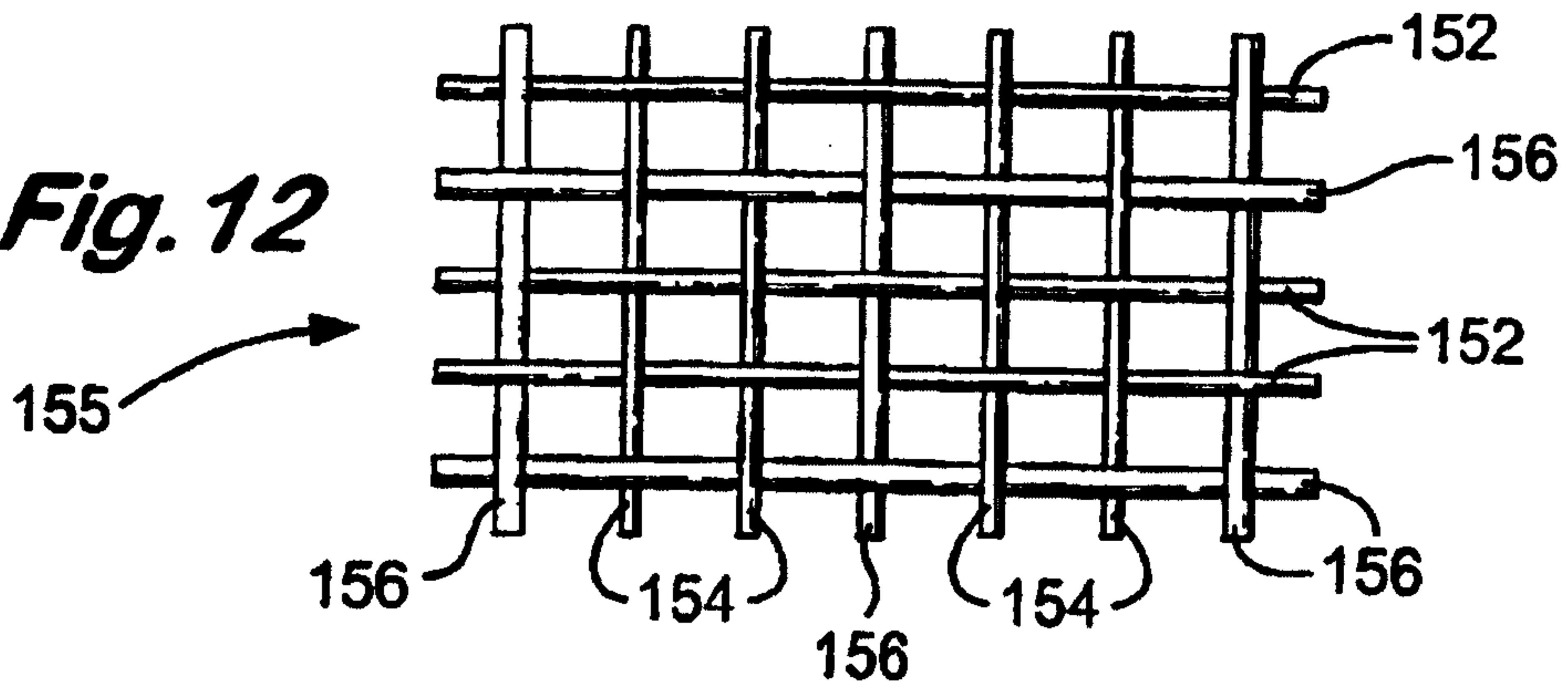

Fig. 12



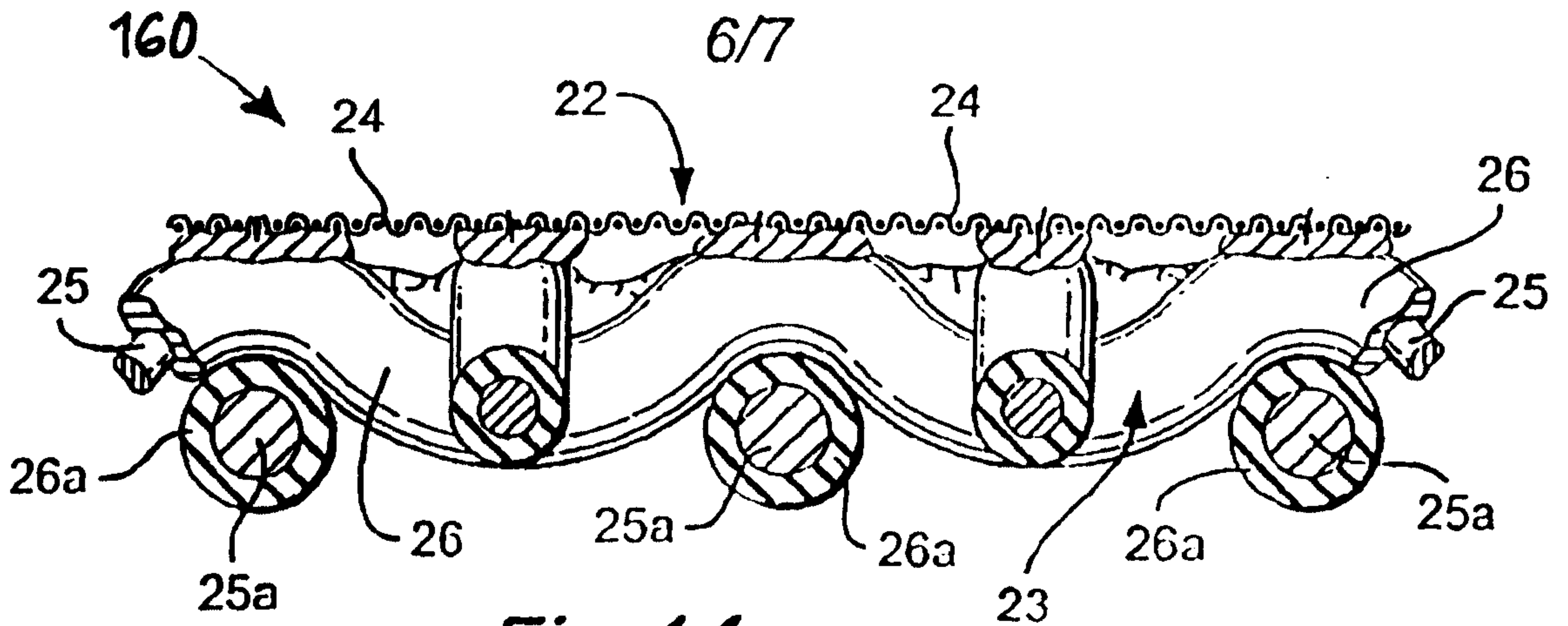

Fig. 14

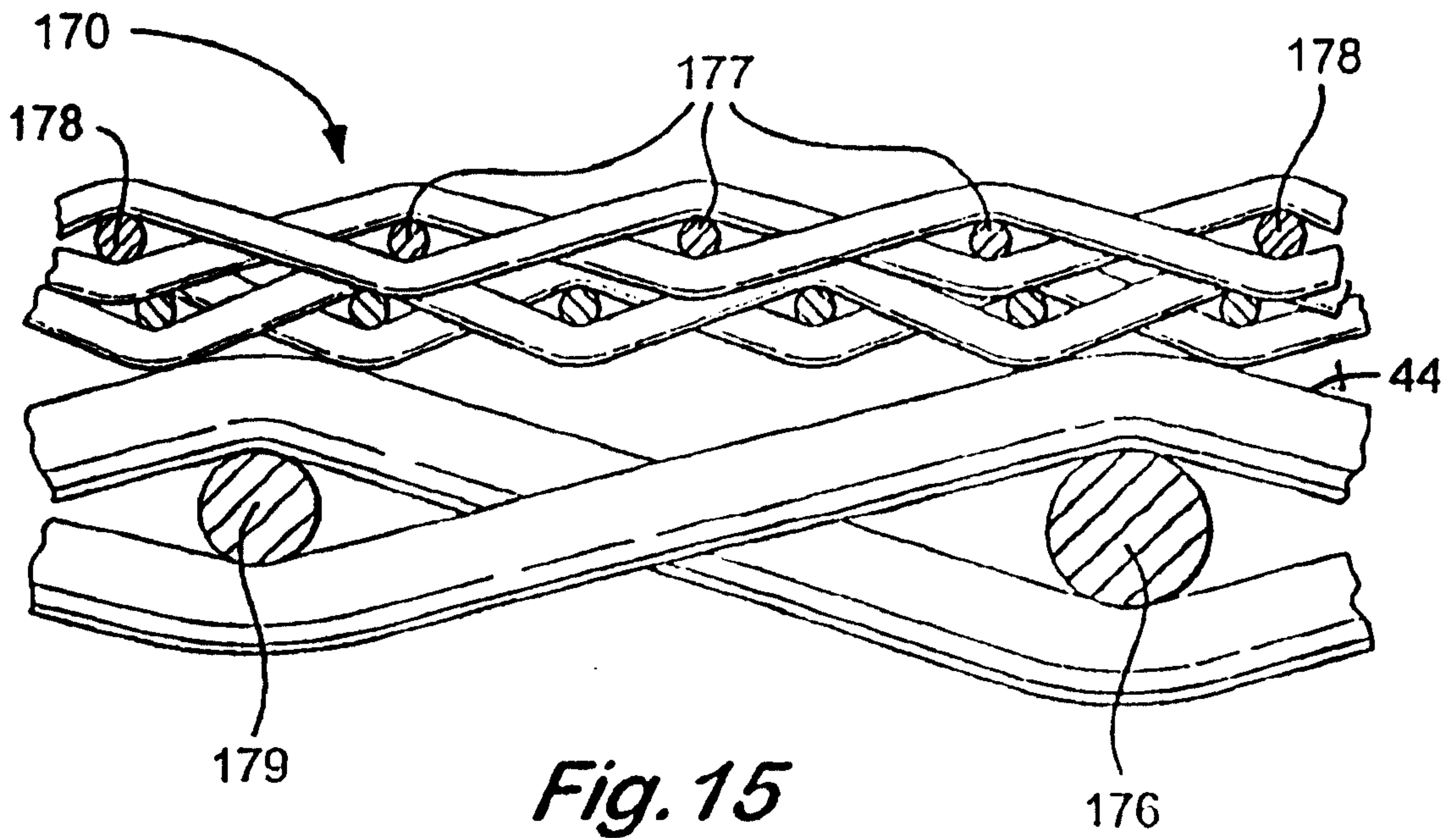

Fig. 15

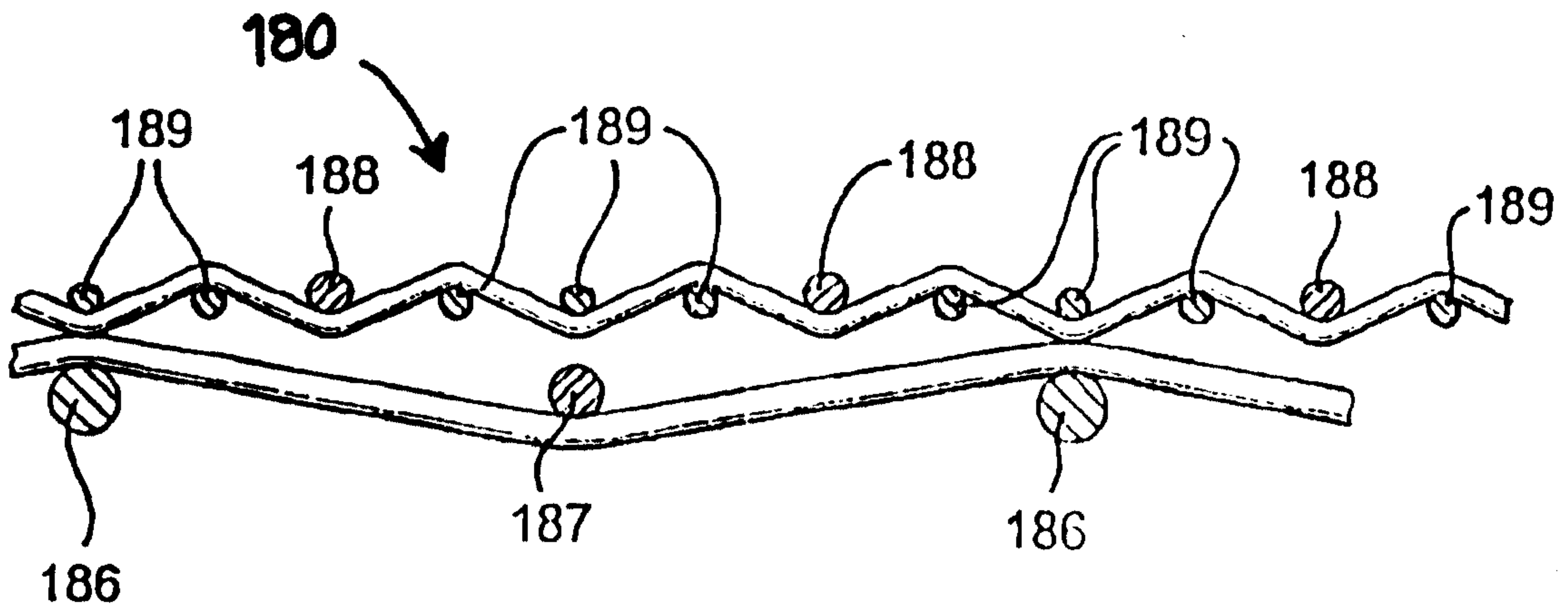

Fig. 16

7/7

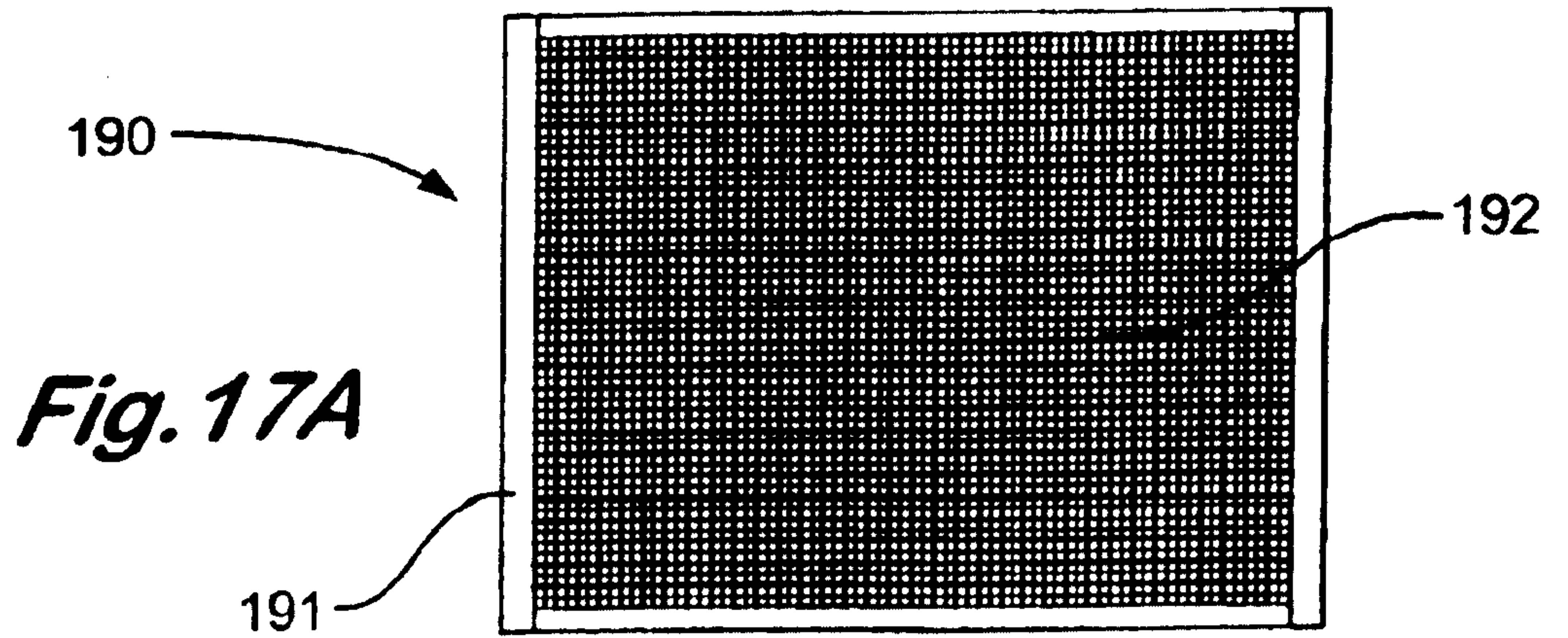

Fig. 17A



Fig. 17B

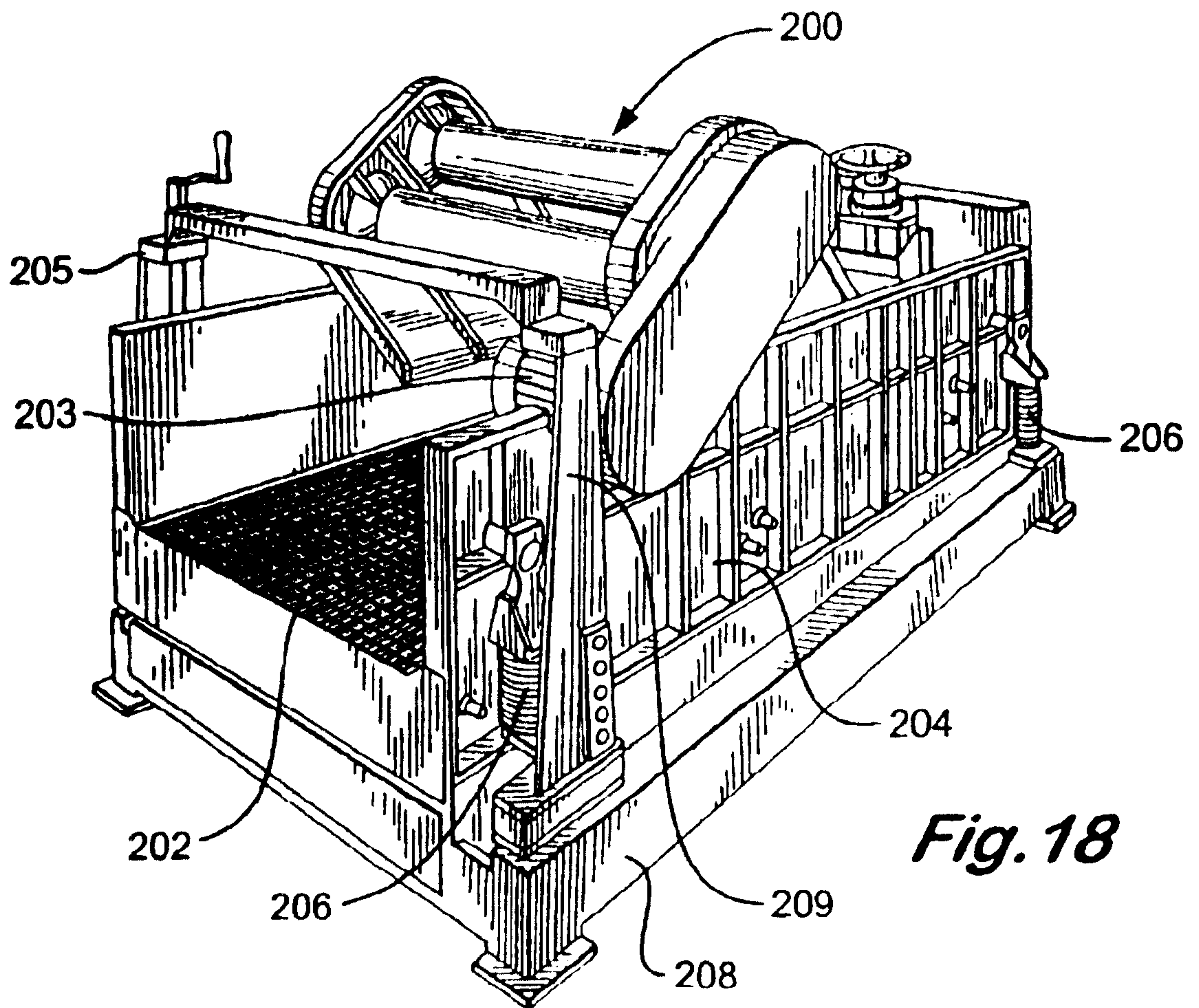

Fig. 18

