



- (51) **International Patent Classification:**
H01L 33/48 (2010.01) H01L 21/60 (2006.01)
H01L 21/677 (2006.01)
- (21) **International Application Number:**
PCT/CN2015/098429
- (22) **International Filing Date:**
23 December 2015 (23.12.2015)
- (25) **Filing Language:** English
- (26) **Publication Language:** English
- (71) **Applicant:** GOERTEK.INC [CN/CN]; 268 Dongfang Road, Hi-Tech Industry District, Weifang, Shandong 261031 (CN).
- (72) **Inventor:** ZOU, Quanbo; 268 Dongfang Road, Hi-Tech Industry District, Weifang, Shandong 261031 (CN).
- (74) **Agent:** BEYOND TALENT PATENT AGENT FIRM; Room 1202, Kuntai Building, #10 Chaoyangmenwai Str., Chaoyang District, Beijing 100020 (CN).
- (81) **Designated States** (unless otherwise indicated, for every kind of national protection available): AE, AG, AL, AM,

AO, AT, AU, AZ, BA, BB, BG, BH, BN, BR, BW, BY, BZ, CA, CH, CL, CN, CO, CR, CU, CZ, DE, DK, DM, DO, DZ, EC, EE, EG, ES, FI, GB, GD, GE, GH, GM, GT, HN, HR, HU, ID, IL, IN, IR, IS, JP, KE, KG, KN, KP, KR, KZ, LA, LC, LK, LR, LS, LU, LY, MA, MD, ME, MG, MK, MN, MW, MX, MY, MZ, NA, NG, NI, NO, NZ, OM, PA, PE, PG, PH, PL, PT, QA, RO, RS, RU, RW, SA, SC, SD, SE, SG, SK, SL, SM, ST, SV, SY, TH, TJ, TM, TN, TR, TT, TZ, UA, UG, US, UZ, VC, VN, ZA, ZM, ZW.

(84) **Designated States** (unless otherwise indicated, for every kind of regional protection available): ARIPO (BW, GH, GM, KE, LR, LS, MW, MZ, NA, RW, SD, SL, ST, SZ, TZ, UG, ZM, ZW), Eurasian (AM, AZ, BY, KG, KZ, RU, TJ, TM), European (AL, AT, BE, BG, CH, CY, CZ, DE, DK, EE, ES, FI, FR, GB, GR, HR, HU, IE, IS, IT, LT, LU, LV, MC, MK, MT, NL, NO, PL, PT, RO, RS, SE, SI, SK, SM, TR), OAPI (BF, BJ, CF, CG, CI, CM, GA, GN, GQ, GW, KM, ML, MR, NE, SN, TD, TG).

Published:
— with international search report (Art. 21(3))

(54) **Title:** MICRO-LED TRANSFER METHOD AND MANUFACTURING METHOD

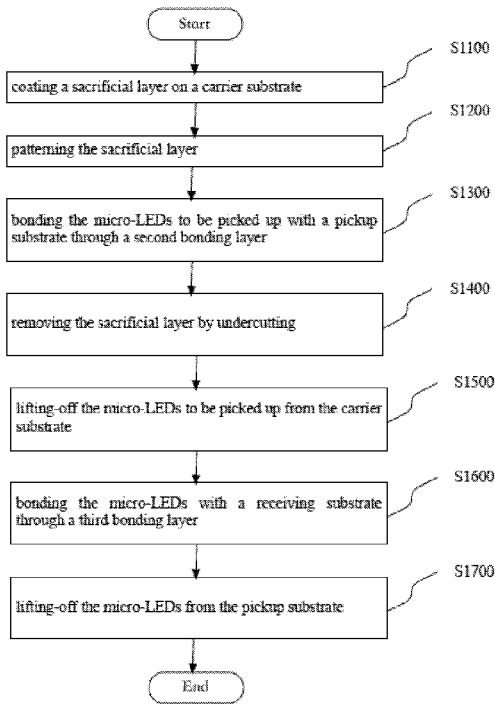

(57) **Abstract:** A micro-LED transfer method and a manufacturing method are disclosed. The micro-LED transfer method comprises: coating a sacrificial layer on a carrier substrate, wherein micro-LEDs are bonded on the carrier substrate through a first bonding layer (S1100); patterning the sacrificial layer to expose micro-LEDs to be picked up (S1200); bonding the micro-LEDs to be picked up with a pickup substrate through a second bonding layer (S1300); removing the sacrificial layer by undercutting (S1400); lifting-off the micro-LEDs to be picked up from the carrier substrate (S1500); bonding the micro-LEDs on the pickup substrate with a receiving substrate through a third bonding layer (S1600); and lifting-off the micro-LEDs from the pickup substrate (S1700).

FIG. 1

WO 2017/107097 A1

MICRO-LED TRANSFER METHOD AND MANUFACTURING METHOD

FIELD OF THE INVENTION

The present invention relates to the technical field of micro-LED, and in particular,
5 relates to a micro-LED transfer method and a method for manufacturing a micro-LED device

BACKGROUND OF THE INVENTION

The micro-LED technology refers to the LED array of small size integrated on a substrate with high density. Currently, the micro-LED technology is under development, and it is expected in the industry that a high-quality micro-LED product comes into the market.
10 High-quality micro-LED will have a deep affection on the conventional display products such as LCD/OLED that have already been put into the market.

Until now, how to transfer micro-LEDs to a receiving substrate of a micro-LED device has always been a technical task to be improved by a technician.

In the prior art, a pickup head is used to transfer micro-LEDs. The approaches using
15 pickup heads are relatively complicated and have problems in the aspects of yield and stability.

For example, the US Patent No. US 8,333,860B1 discloses a micro device transfer head and a method of transferring one or more micro devices to a receiving substrate. This patent is hereby incorporated herein as a whole as a reference.

20 The US Patent No. US 8,426,227B1 discloses a micro light emitting diode LED and a method of forming an array of micro LEDs for transfer to a receiving substrate. This patent is hereby incorporated herein as a whole as a reference.

SUMMARY OF THE INVENTION

One object of this invention is to provide a new technical solution for micro-LED
25 transfer.

According to a first aspect of the present invention, there is provided a micro-LED transfer method, comprising: coating a sacrificial layer on a carrier substrate, wherein micro-LEDs are bonded on the carrier substrate through a first bonding layer; patterning the sacrificial layer to expose micro-LEDs to be picked up; bonding the micro-LEDs to be picked up
5 with a pickup substrate through a second bonding layer; removing the sacrificial layer by undercutting; lifting-off the micro-LEDs to be picked up from the carrier substrate; bonding the micro-LEDs on the pickup substrate with a receiving substrate through a third bonding layer; and lifting-off the micro-LEDs from the pickup substrate.

Preferably, the first bonding layer and the second bonding layer are of solder layers and
10 the second bonding layer is of polymer.

Preferably, the lifting-off characteristics of the first bonding layer and the second bonding layer are different from that of the second bonding layer.

Preferably, the melting point of the first bonding layer is lower than 280°C, and the micro-LEDs to be picked up are lifted-off from the carrier substrate through heating.

15 Preferably, the second bonding layer is a thermal release tape, or an UV curable and laser de-bondable film.

Preferably, the sacrificial layer is a photo resist and the sacrificial layer is patterned through photo lithography.

Preferably, the sacrificial layer is removed through etchant.

20 Preferably, the side-length of the micro-LEDs is 1-100μm.

Preferably, the material of the pickup substrate includes one of glass, sapphire, quartz and silicon.

According to a second aspect of the present invention, there is provided method for manufacturing a micro-LED device, comprising transferring micro-LEDs to a receiving substrate
25 of the micro-LED device by using the micro-LED transfer method of the present invention.

Compared with the prior art, the complicated pickup head is not necessary in this invention, and the technical solution of this invention is relatively simple. So, the task to be implemented by or the technical problem to be solved by the present invention has not been conceived or anticipated by a person skilled in the art and thus the present invention is a

new solution.

Further features of the present invention and advantages thereof will become apparent from the following detailed description of exemplary embodiments according to the present invention with reference to the attached drawings.

5

BRIEF DISCRIPTION OF THE DRAWINGS

The accompanying drawings, which are incorporated in and constitute a part of the specification, illustrate embodiments of the invention and, together with the description thereof, serve to explain the principles of the invention.

Figure 1 is a flow chart of the method according to an embodiment of the present invention.

Figures 2-15 is a schematic diagram of an example for micro-LED transfer according to the present invention.

DETAILED DESCRIPTION OF THE EMBODIMENTS

Various exemplary embodiments of the present invention will now be described in detail with reference to the drawings. It should be noted that the relative arrangement of the components and steps, the numerical expressions, and numerical values set forth in these embodiments do not limit the scope of the present invention unless it is specifically stated otherwise.

The following description of at least one exemplary embodiment is merely illustrative in nature and is in no way intended to limit the invention, its application, or uses.

Techniques, methods and apparatus as known by one of ordinary skill in the relevant art may not be discussed in detail but are intended to be part of the specification where appropriate.

In all of the examples illustrated and discussed herein, any specific values should be interpreted to be illustrative only and non-limiting. Thus, other examples of the exemplary embodiments could have different values.

Notice that similar reference numerals and letters refer to similar items in the

following figures, and thus once an item is defined in one figure, it is possible that it need not be further discussed for following figures.

Below, the embodiments and examples will be described with reference to the accompany figures.

5 Figure 1 shows the flow chart of a micro-LED transfer method according to an embodiment of the present invention.

As show in Figure 1, at step S1100, a sacrificial layer is coated on a carrier substrate, wherein micro-LEDs are bonded on the carrier substrate through a first bonding layer.

10 For example, the micro-LEDs can be lateral micro-LEDs or vertical micro-LEDs. The side-length of the micro-LEDs can be 1-100 μ m.

The first bonding layer can be a solder layer. The solder can be a metal or alloy with a relatively low melting point, or the combination thereof. Preferably, the melting point of the solder is lower than 280 $^{\circ}$ C; more preferably, lower than 200 $^{\circ}$ C; and even more preferably, lower than 160 $^{\circ}$ C.

15 At step S1200, the sacrificial layer is patterned to expose micro-LEDs to be picked up.

The sacrificial layer can be a photo resist. The sacrificial layer can be patterned through photo lithography. Of course, a person skilled in the art can pattern the sacrificial layer through other approaches.

20 At step S1300, the micro-LEDs to be picked up are boned with a pickup substrate through a second bonding layer.

The material of the pickup substrate can include one of glass, sapphire, quartz and silicon. The second bonding layer can be a thermal release tape, or an UV curable and laser de-bondable film.

At step S1400, the sacrificial layer is removed by undercutting.

25 For example, the sacrificial layer can be removed by chemical undercutting. For example, an etchant can be used. The etchant is a solvent such as acetone.

At step S1500, the micro-LEDs to be picked up are lifted-off from the carrier substrate.

For example, in the situation where the first bonding layer has a relatively low melting point, the micro-LEDs to be picked up can be lifted-off from the carrier substrate through heating.

At step S1600, the micro-LEDs on the pickup substrate are bonded with a receiving
5 substrate through a third bonding layer.

At step S1700, the micro-LEDs are lifted-off from the pickup substrate.

Based on the teaching of the present invention, a person skilled in the art would easily understand that the technical solution of the present invention per se has already indicated that the micro-LEDs can remain on the second bonding layer (the pickup substrate)
10 when being lifted-off from the first bonding layer (the carrier substrate), and the micro-LEDs can remain on the third bonding layer (the receiving substrate) when being lifted-off from the second bonding layer (the pickup substrate). For example, the lifting-off characteristic of the first bonding layer is different from that of the second bonding layer, so that the micro-LEDs can be transferred from the carrier substrate to the pickup substrate.
15 Furthermore, the lifting-off characteristic of the second bonding layer is different from that of the third bonding layer, so that the micro-LEDs can be transferred from the pickup substrate to the receiving substrate. The lifting-off characteristic can include lifting-off temperature, lifting-off approach and so on.

For example, the micro-LEDs can be lifted-off from the carrier substrate through
20 heating, and can be lifted-off from the pickup substrate through a laser lifting-off.

In an example, the first bonding layer is a solder layer with low melting point, the second bonding layer is a polymer layer, and the third bonding layer is a solder layer having a relatively high melting point after bonding. In this situation, the first bonding layer can be lifted-off through heating at a first temperature, and the second bonding layer can be
25 lifted-off through heating at a second temperature, wherein the first temperature is lower than the second temperature.

In a preferable embodiment, alternatively, the lifting-off can be performed through a contactless manner. For example, when lifting-off, the micro-LEDs are kept on the pickup substrate or the receiving substrate through at least one of gravity, electrostatic force or

magnetic force. The electrostatic force can be applied via the pads or bonding layers on the pickup substrate or the receiving substrate, for example. The magnetic force can be applied from the side of the pickup substrate or the receiving substrate, for example.

In the case where the present invention has already taught that the first bonding
5 layer and the second bonding layer are to be lifted-off individually, this teaching is sufficient for a person skilled in the art to readily conceive a lot of manners to individually lift-off the bonding layers, even if some of the manners are inventive. Thus, the detailed descriptions for various specific lifting-off approaches are omitted in this specification.

Compared with the technique of pickup head in the prior art, the present invention
10 does not need the manufacturing of a complicated pickup head, and thus the technical solution of the present invention is relatively simple. This can further reduce the cost to a certain degree.

Furthermore, the pickup substrates rather than pickup head arrays can easily be used for a large scale processing. So, the yield can be improved by the present invention.

15 Furthermore, compared with the electrostatic pickup of a pickup head, the present invention can improve the stability of pickup to a certain degree.

In another embodiment, the present invention can further include a method for manufacturing a micro-LED device. The manufacturing method comprises transfer
20 micro-LEDs to a receiving substrate of the micro-LED device by using the above micro-LED transfer method. The micro-LED device is a display screen device, for example, and the receiving substrate is a display panel or a display substrate, for example.

Furthermore, the present invention can further include the micro-LED device manufactured by the above manufacturing method and/or an electronics apparatus comprising said micro-LED device, such as a mobile phone, pad and so on.

25 Figures 2-15 show an example for micro-LED transfer according to the present invention.

As shown in Figure 2, red micro-LEDs 3r are bonded on the carrier substrate 1 through a first bonding layer 2. The first bonding layer 2 is, for example, a solder layer or an adhesive tape layer. The micro-LEDs can include p-metal, trench, dielectric and so on.

As shown in Figure 3, a sacrificial layer 4 is coated on the carrier substrate 1. The sacrificial layer 4 covers the micro-LEDs 3r. The sacrificial layer 4 is patterned to expose micro-LEDs 3r to be picked up, as indicated by the reference sign 5 in Figure 3. The sacrificial layer 4 can photo resist, and the sacrificial layer 4 can be patterned through photo lithography.

As shown in Figure 4, the micro-LEDs 3r to be picked up are bonded onto a pickup substrate 7 through a second bonding layer 6.

The material of the second bonding layer 6 can be bonding polymer. The bonding polymer can, for example, be an UV curable and laser de-bondable film (such as 3M LC5320 available in the market), a thermal release tape, a high temperature UV tape (such as the UV releasable two-sides tape of Nitto Denko), or a photo resist different for the sacrificial layer (which can be removed by using different solvent).

As shown in Figure 5, the sacrificial layer 4 is removed by undercutting. For example, the sacrificial layer is removed by using solvent (etchant) such as acetone.

As shown in Figure 6, the micro-LEDs to be picked up are lifted-off from the carrier substrate. For example, the first bonding layer 2 is a solder layer with relatively low melting point. The solder of the first bonding layer 2 is melted through heating, and then the pickup substrate 7 is lifted up to lift-off the micro-LEDs to be picked up.

As shown in Figure 7, the red micro-LEDs 3r are picked up by the pickup substrate.

As shown in Figures 8 and 9, the above steps can be repeated to pick up green micro-LEDs 3g and blue micro-LEDs 3b.

As shown in Figure 10, the micro-LEDs 3r on the pickup substrate are bonded with a receiving substrate 8 through the third bonding layer 9. As shown in Figure 11, the micro-LEDs 3r are lifted-off from the pickup substrate 7. For example, the micro-LED 3r can be lifted-off by laser lifting-off or thermal release and so on. As such, the red micro-LED 3r are transferred to the receiving substrate 8.

As shown in Figures 12 and 13, the green micro-LEDs 3g can be transferred to the receiving substrate 8 by using the same approach.

As shown in Figures 14 and 15, the blue micro-LEDs 3b can be transferred to the

receiving substrate 8 by using the same approach.

In an example, in order to remedy the faults of certain micro-LEDs, redundant micro-LEDs can be provided by using redundant technique. As such, when a certain micro-LED does not work, a redundant micro-LED corresponding to it can be used, thereby
5 improving the quality of a display device.

Although some specific embodiments of the present invention have been demonstrated in detail with examples, it should be understood by a person skilled in the art that the above examples are only intended to be illustrative but not to limit the scope of the present invention. It should be understood by a person skilled in the art that the above
10 embodiments can be modified without departing from the scope and spirit of the present invention. The scope of the present invention is defined by the attached claims.

CLAIMS

What is claimed is:

1. A micro-LED transfer method, comprising:
 - coating a sacrificial layer on a carrier substrate, wherein micro-LEDs are bonded on the
 - 5 carrier substrate through a first bonding layer;
 - patterning the sacrificial layer to expose micro-LEDs to be picked up;
 - bonding the micro-LEDs to be picked up with a pickup substrate through a second
 - bonding layer;
 - removing the sacrificial layer by undercutting;
 - 10 lifting-off the micro-LEDs to be picked up from the carrier substrate;
 - bonding the micro-LEDs on the pickup substrate with a receiving substrate through a
 - third bonding layer; and
 - lifting-off the micro-LEDs from the pickup substrate.
- 15 2. The method according to claim 1, wherein the first bonding layer and the second bonding layer are of solder layers and the second bonding layer is of polymer.
3. The method according to claim 1 or 2, wherein the lifting-off characteristics of the first bonding layer and the second bonding layer are different from that of the second bonding layer.
- 20 4. The method according to anyone of claims 1-3, wherein the melting point of the first bonding layer is lower than 280°C, and the micro-LEDs to be picked up are lifted-off from the carrier substrate through heating.
- 25 5. The method according to anyone of claims 1-4, wherein the second bonding layer is a thermal release tape, or an UV curable and laser de-bondable film.

6. The method according to anyone of claims 1-5, wherein the sacrificial layer is a photo resist and the sacrificial layer is patterned through photo lithography.

7. The method according to anyone of claims 1-6, wherein the sacrificial layer is
5 removed through etchant.

8. The method according to anyone of claims 1-7, wherein the side-length of the micro-LEDs is 1-100 μ m.

10 9. The method according to anyone of claims 1-8, wherein the material of the pickup substrate includes one of glass, sapphire, quartz and silicon.

15 10. A method for manufacturing a micro-LED device, comprising transferring micro-LEDs to a receiving substrate of the micro-LED device by using the method according to anyone of claims 1-9.

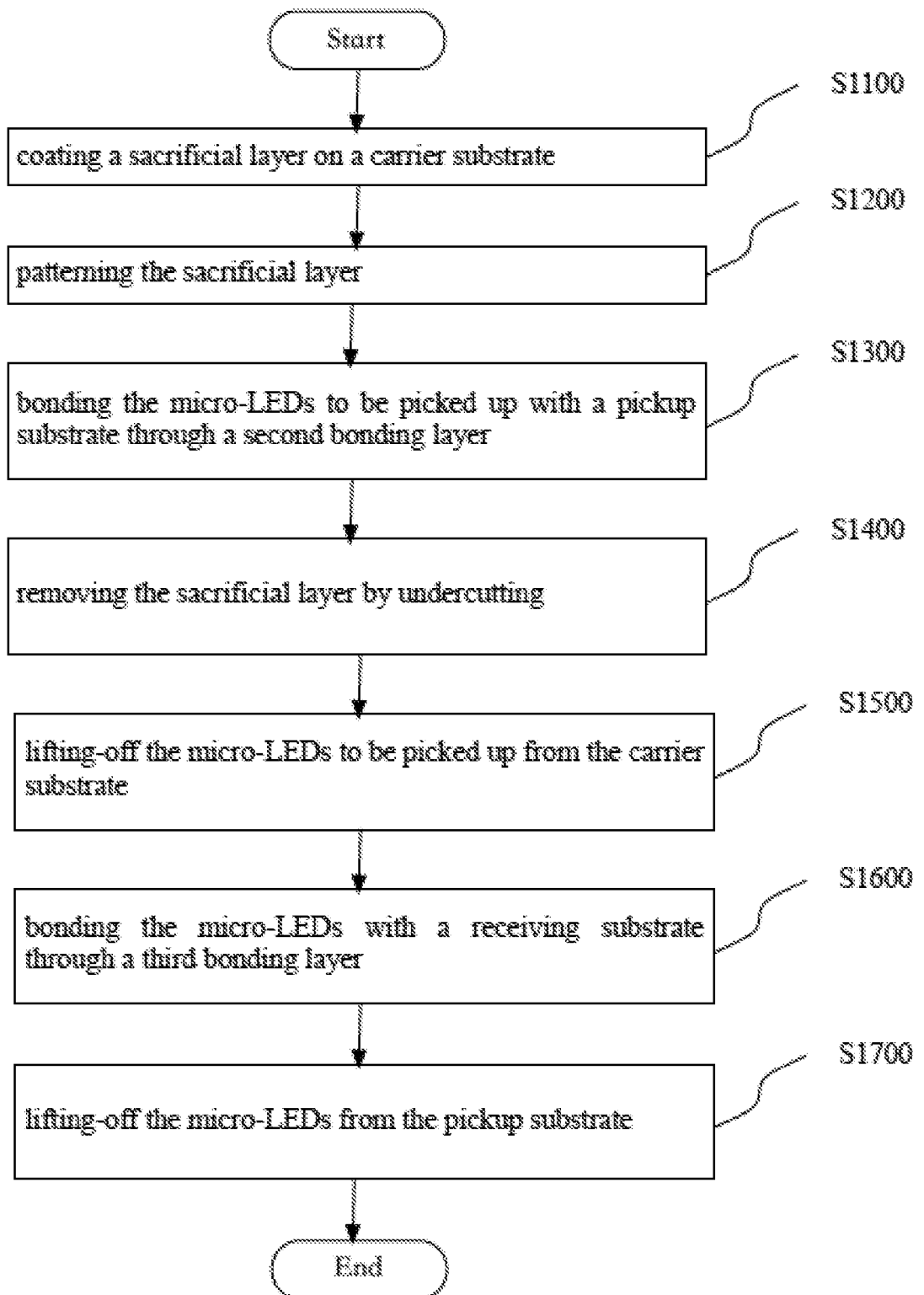

FIG. 1

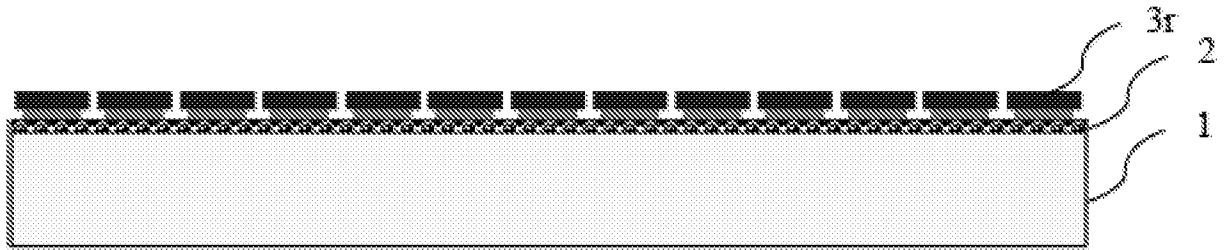

FIG. 2

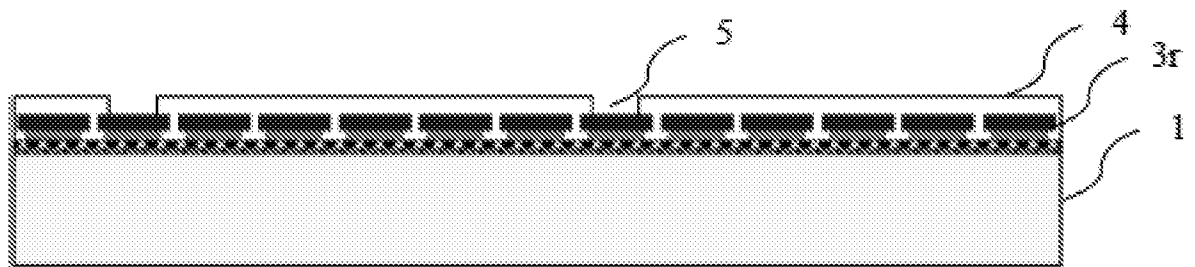

FIG. 3

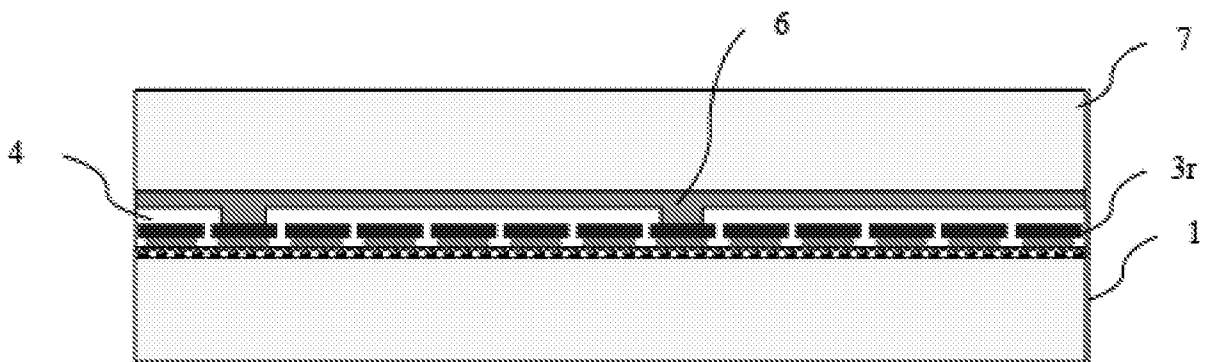

FIG. 4

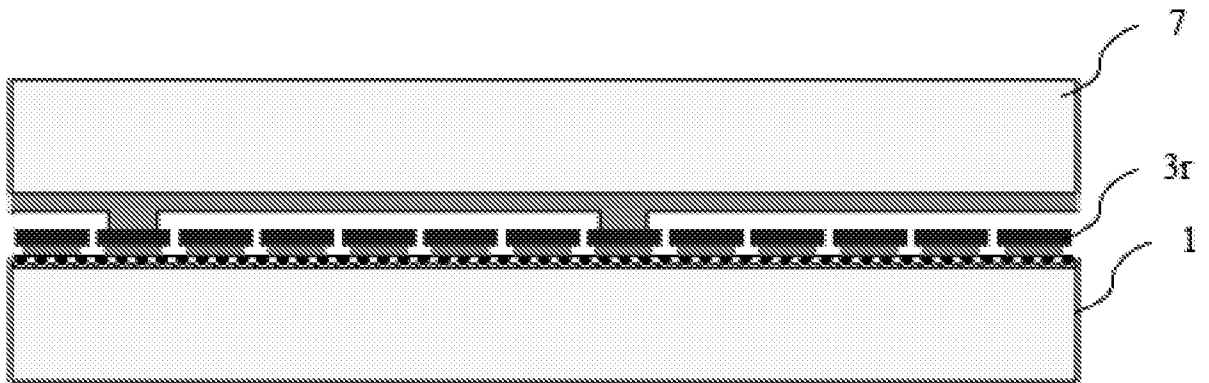

FIG. 5

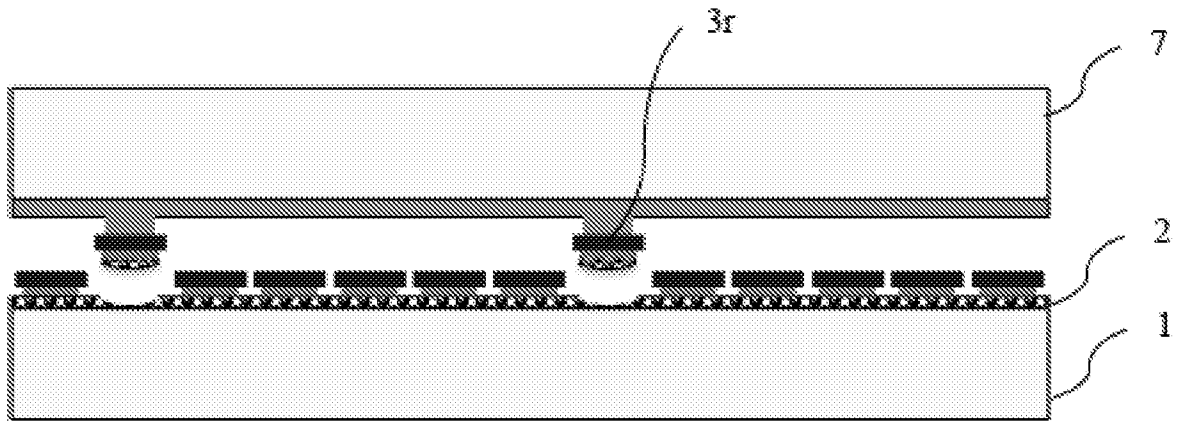

FIG. 6

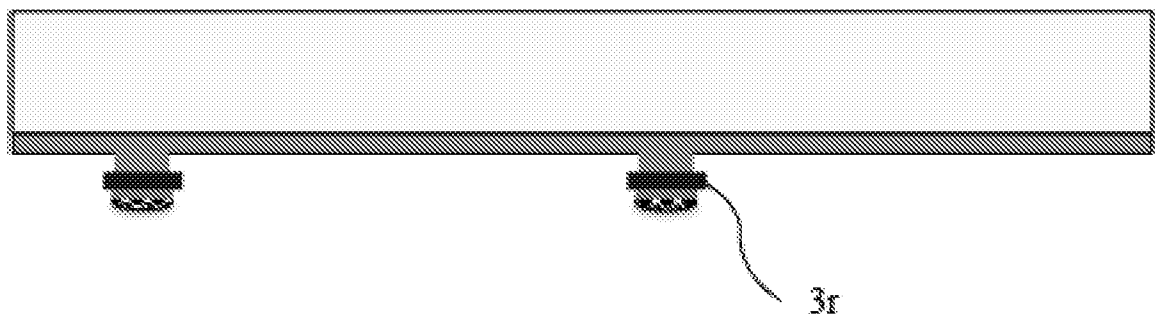

FIG. 7

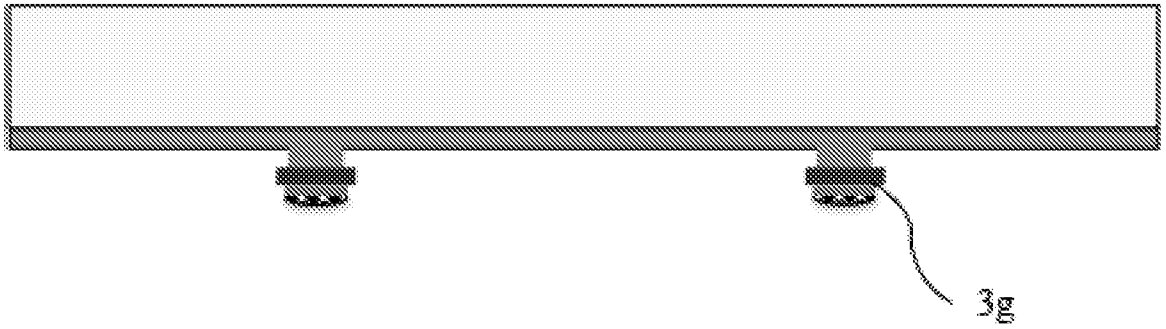

FIG. 8

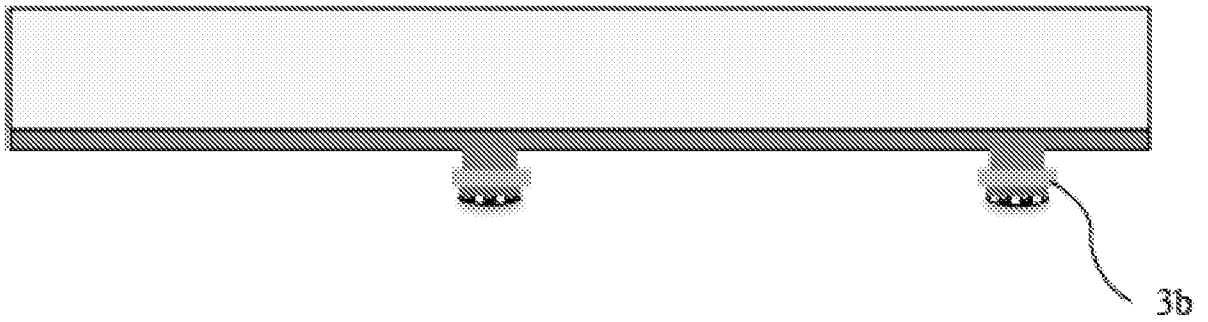

FIG. 9

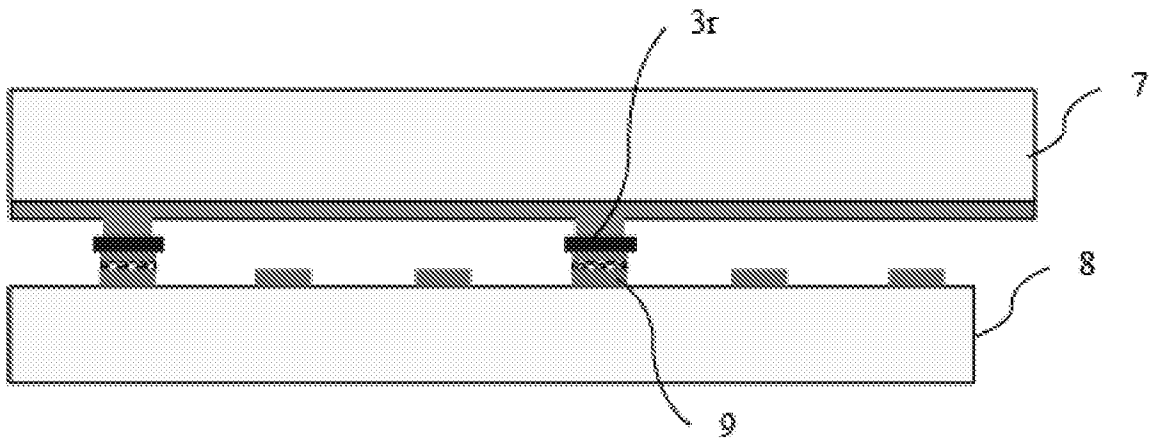

FIG. 10

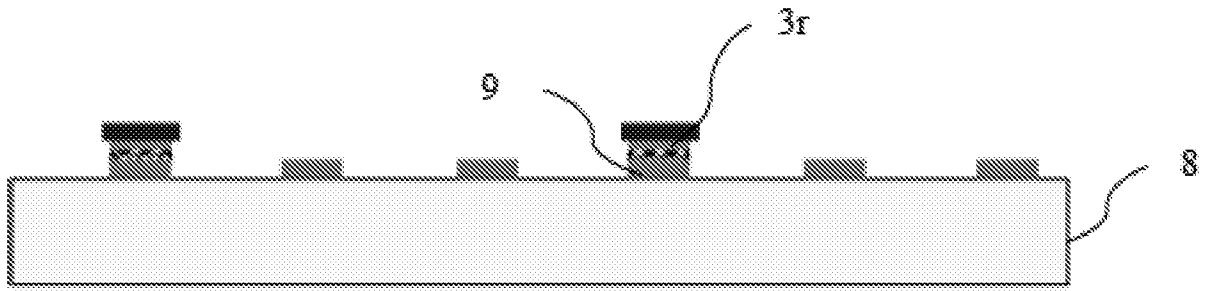

FIG. 11

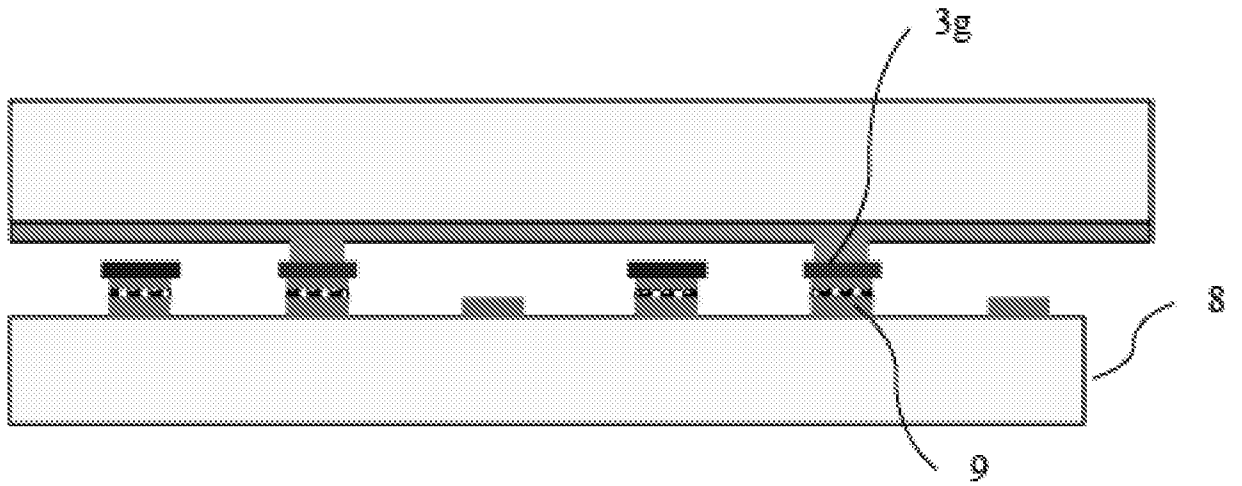

FIG. 12

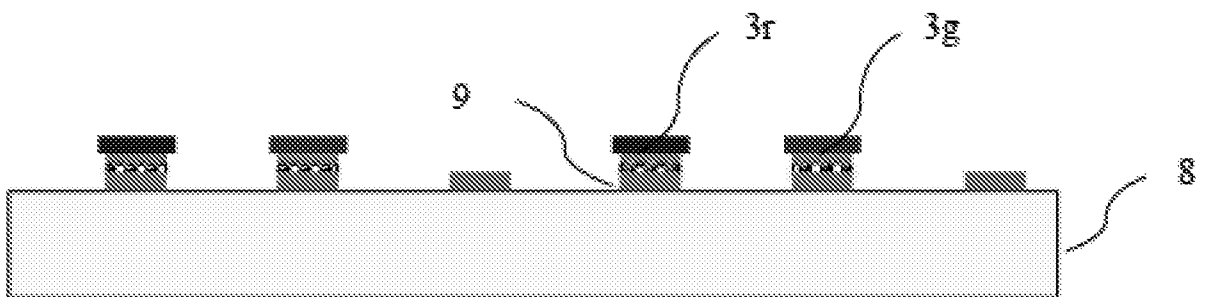

FIG. 13

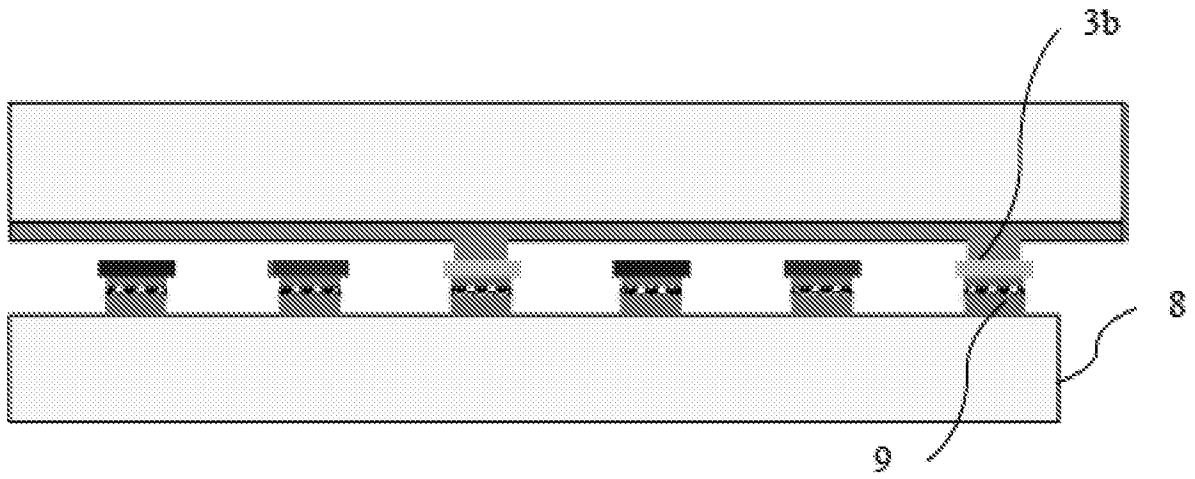

FIG. 14

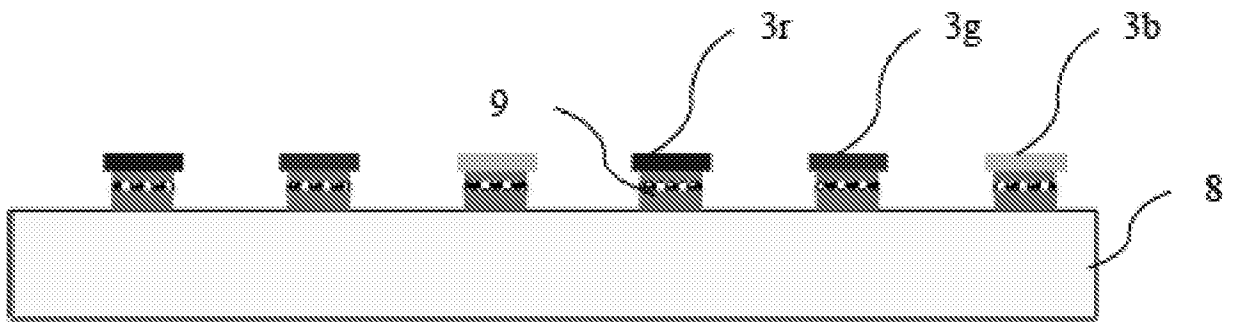

FIG. 15

INTERNATIONAL SEARCH REPORT

International application No.

PCT/CN2015/098429**A. CLASSIFICATION OF SUBJECT MATTER**

H01L 33/48(2010.01)i; H01L 21/677(2006.01)i; H01L 21/60(2006.01)i

According to International Patent Classification (IPC) or to both national classification and IPC

B. FIELDS SEARCHED

Minimum documentation searched (classification system followed by classification symbols)

H01L, H05K

Documentation searched other than minimum documentation to the extent that such documents are included in the fields searched

Electronic data base consulted during the international search (name of data base and, where practicable, search terms used)

EPODOC, WPI, CNKI, CNPAT: transfer+, pick+, lift+, strip+, peel+

C. DOCUMENTS CONSIDERED TO BE RELEVANT

Category*	Citation of document, with indication, where appropriate, of the relevant passages	Relevant to claim No.
X	US 2014340900 A1 (LUXVUE TECHNOLOGY CORPORATION) 20 November 2014 (2014-11-20) description paragraphs [0051]- [0074] and [0089]- [0099], figures 1A-1L and 6A-6G	1-10
A	CN 101211809 A (SAMSUNG ELECTRONICS CO., LTD.) 02 July 2008 (2008-07-02) the whole document	1-10
A	CN 1513204 A (COMMISSARIAT ENERGIE ATOMIQUE) 14 July 2004 (2004-07-14) the whole document	1-10
A	JP 2008060608 A (SONY CORP.) 13 March 2008 (2008-03-13) the whole document	1-10

 Further documents are listed in the continuation of Box C. See patent family annex.

* Special categories of cited documents:

"A" document defining the general state of the art which is not considered to be of particular relevance

"E" earlier application or patent but published on or after the international filing date

"L" document which may throw doubts on priority claim(s) or which is cited to establish the publication date of another citation or other special reason (as specified)

"O" document referring to an oral disclosure, use, exhibition or other means

"P" document published prior to the international filing date but later than the priority date claimed

"T" later document published after the international filing date or priority date and not in conflict with the application but cited to understand the principle or theory underlying the invention

"X" document of particular relevance; the claimed invention cannot be considered novel or cannot be considered to involve an inventive step when the document is taken alone

"Y" document of particular relevance; the claimed invention cannot be considered to involve an inventive step when the document is combined with one or more other such documents, such combination being obvious to a person skilled in the art

"&" document member of the same patent family

Date of the actual completion of the international search

09 March 2016

Date of mailing of the international search report

25 March 2016

Name and mailing address of the ISA/CN

**STATE INTELLECTUAL PROPERTY OFFICE OF THE
P.R.CHINA
6, Xitucheng Rd., Jimen Bridge, Haidian District, Beijing
100088, China**

Facsimile No. (86-10)62019451

Authorized officer

ZHAO,Zhimin

Telephone No. (86-10)62413274

INTERNATIONAL SEARCH REPORT
Information on patent family members

International application No.

PCT/CN2015/098429

Patent document cited in search report			Publication date (day/month/year)	Patent family member(s)			Publication date (day/month/year)
US	2014340900	A1	20 November 2014	US	9217541	B2	22 December 2015
CN	101211809	A	02 July 2008	KR	100834837	B1	03 June 2008
				TW	200834794	A	16 August 2008
				JP	2008166774	A	17 July 2008
				US	2008160725	A1	03 July 2008
CN	1513204	A	14 July 2004	KR	100878059	B1	14 January 2009
				WO	02082502	A2	17 October 2002
				JP	4249490	B2	02 April 2009
				DE	60205358	D1	08 September 2005
				EP	1386346	A2	04 February 2004
				FR	2823012	B1	21 May 2004
				CN	1322575	C	20 June 2007
				US	2004104272	A1	03 June 2004
				DE	60205358	T2	06 July 2006
				TW	I255486	B	21 May 2006
				US	6959863	B2	01 November 2005
				EP	1386346	B1	03 August 2005
				AT	301332	T	15 August 2005
				FR	2823012	A1	04 October 2002
				JP	2004526323	A	26 August 2004
				WO	02082502	A3	06 November 2003
				KR	20030090706	A	28 November 2003
				MY	124843	A	31 July 2006
				SG	100243	B	31 March 2006
JP	2008060608	A	13 March 2008	JP	4605207	B2	05 January 2011