

(19) World Intellectual Property Organization  
International Bureau



(43) International Publication Date  
8 May 2003 (08.05.2003)

PCT

(10) International Publication Number  
**WO 03/037638 A1**

- (51) International Patent Classification<sup>7</sup>: **B41J 19/20**
  - (21) International Application Number: PCT/US02/27927
  - (22) International Filing Date: 28 August 2002 (28.08.2002)
  - (25) Filing Language: English
  - (26) Publication Language: English
  - (30) Priority Data:
    - 10/004,434 31 October 2001 (31.10.2001) US
    - 10/000,829 31 October 2001 (31.10.2001) US
  - (71) Applicant (for all designated States except US): **HEWLETT-PACKARD COMPANY** [US/US]; M/S 1068, 3000 Hanover Street, Palo Alto, CA 94304-1112 (US).
  - (72) Inventors; and
  - (75) Inventors/Applicants (for US only): **ALLEN, William, J.** [US/US]; 3415 SW Cascade Avenue, Corvallis, OR 97333 (US). **ROSS, George, C.** [US/US]; 22150 Harris Road, Philomath, OR 97370 (US).
  - (74) Agents: **AUCIELLO, Lucinda, G.**; Hewlett-Packard Company, P.O. Box 272400, Fort Collins, CO 80527-2400 et al. (US).
  - (81) Designated States (national): AE, AG, AL, AM, AT, AU, AZ, BA, BB, BG, BR, BY, BZ, CA, CH, CN, CO, CR, CU, CZ, DE, DK, DM, DZ, EC, EE, ES, FI, GB, GD, GE, GH, GM, HR, HU, ID, IL, IN, IS, JP, KE, KG, KP, KR, KZ, LC, LK, LR, LS, LT, LU, LV, MA, MD, MG, MK, MN, MW, MX, MZ, NO, NZ, OM, PH, PL, PT, RO, RU, SD, SE, SG, SI, SK, SL, TJ, TM, TN, TR, TT, TZ, UA, UG, US, UZ, VC, VN, YU, ZA, ZM, ZW.
  - (84) Designated States (regional): ARIPO patent (GH, GM, KE, LS, MW, MZ, SD, SL, SZ, TZ, UG, ZM, ZW), Eurasian patent (AM, AZ, BY, KG, KZ, MD, RU, TJ, TM), European patent (AT, BE, BG, CH, CY, CZ, DE, DK, EE, ES, FI, FR, GB, GR, IE, IT, LU, MC, NL, PT, SE, SK, TR), OAPI patent (BF, BJ, CF, CG, CI, CM, GA, GN, GQ, GW, ML, MR, NE, SN, TD, TG).
- Published:**
- with international search report
  - with amended claims

[Continued on next page]

(54) Title: IMAGE FORMING APPARATUS HAVING POSITION SENSING DEVICE

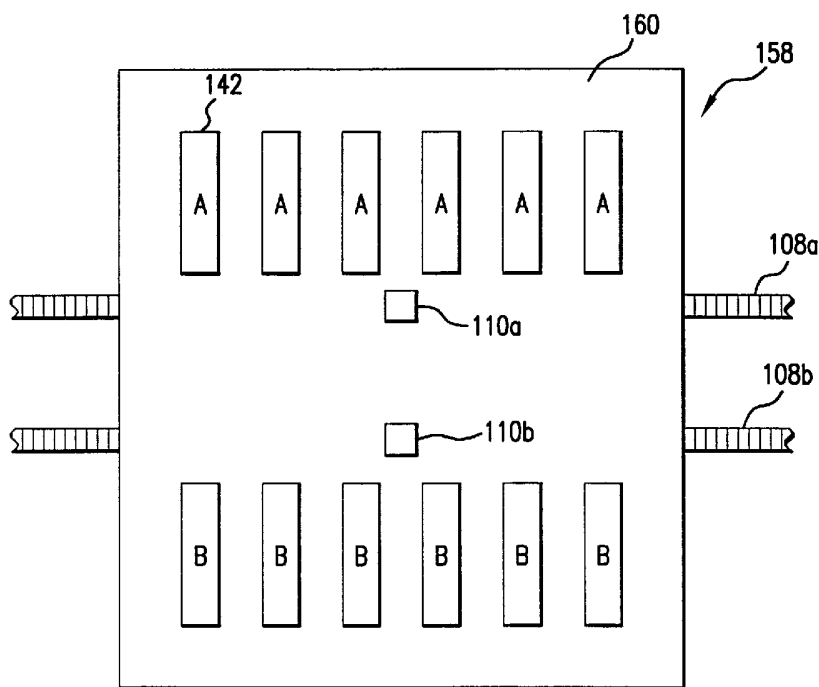

(57) Abstract: An image forming apparatus (100) having a position sensing device (108, 108a, 108b, 110a, 110b, 180a, 180b, 182a, 182b) independently sensing the position of at least two locations on a movable print device (104, 158, 158', 170, 176, 184).



WO 03/037638 A1



---

*For two-letter codes and other abbreviations, refer to the "Guidance Notes on Codes and Abbreviations" appearing at the beginning of each regular issue of the PCT Gazette.*

## IMAGE FORMING APPARATUS HAVING POSITION SENSING DEVICE

### FIELD

The present disclosure relates to an image forming apparatus and, more specifically, to an image forming apparatus having a position sensing device.

### BACKGROUND

Image forming apparatus are used to form text and graphic images on a variety of print media including, but not limited to, paper, card stock, mylar and transparency stock. Certain image forming apparatus include a print device that consists of a scanning carriage and one or more printing elements. During an image forming operation, the scanning carriage will traverse back and forth over the surface of the print media along the scan axis. As the scanning carriage traverses back and forth, a controller causes the printing element(s) to print at positions intended to result in portions of the desired image. The print media is periodically advanced along the media axis, which is transverse to that of the movement scanning carriage, so that the image may be completed.

One example of an image forming apparatus with this type of print device is an ink jet printer. Here, one or more ink jet pens are carried by the scanning carriage. The pens often include a printhead with a plurality of ink ejecting nozzles arranged in a two-dimensional array of rows and columns that print individual ink spots (or "drops") as the carriage scans across the media. A 600 dpi (dots-per-inch) printhead with a ½ inch swath will, for example, typically have two columns with 150 nozzles in each column. Ink drops are fired through the nozzles by an ink

ejection mechanism, such as a piezo-electric or thermal ejection mechanism, to create the desired dot pattern (or "image").

The ability to accurately track the position of the printing elements as the scanning carriage moves along the scan axis is typically important, regardless of the type of printing element that is carried by the carriage, because position data is used to more accurately control the printing process and reduce dot placement and other printing errors. A linear encoder strip and sensor arrangement are frequently used for this purpose. The encoder strip, which includes a series of graduations, is mounted in parallel with the scan axis and the sensor, such as a light source and detector, is carried by the carriage in close proximity to the encoder strip. Position information from the encoder strip and sensor arrangement is used to control actuation of the printing element and, in the case of an ink jet printer pen, the firing of individual nozzles on the pens. Position information may also be used to control carriage movement.

The accuracy of a conventional encoder strip and sensor arrangement decreases as the distance between the sensor and the printing element increases because the relative positions of the printing elements and sensor do not remain constant during a printing operation. This is due to the fact that there is typically some "slop" in the bearings that support the scanning carriage and some flexure of the carriage as it moves along the scan axis. In a multi-printing element image forming apparatus, such as an ink jet printer with a plurality of pens, the distance between some of the printing elements and the sensor can be relatively large, which adversely affects the positional accuracy of those printing elements by increasing the likelihood of dot placement errors. The same problems may be encountered when relatively tall printing elements (i.e. elongated in the media axis) that print relatively tall swaths are used. Here, the distance between the sensor and certain portions of the relatively tall printing element may be large enough to result in erroneous position data for those portions and dot placement or, possibly, other printing errors.

## SUMMARY

An apparatus that senses the position of at least two locations on a movable print device may be provided in accordance with one embodiment of a present invention.

## BRIEF DESCRIPTION OF THE DRAWINGS

Detailed description of preferred embodiments of the inventions will be made with reference to the accompanying drawings.

Figure 1 is a perspective view of an image forming apparatus in accordance with a preferred embodiment of a present invention.

Figure 2 is a schematic block diagram of the image forming apparatus illustrated in Figure 1.

Figure 3 is a perspective view of a print device in accordance with one embodiment of a present invention.

Figure 4 is a schematic block diagram of a print device and sensor system in accordance with a preferred embodiment of a present invention.

Figure 5 is a perspective view of a print device in accordance with one embodiment of a present invention.

Figure 6 is a schematic block diagram of a print device and sensor system in accordance with a preferred embodiment of a present invention.

Figure 7 is a schematic block diagram of a print device and sensor system in accordance with a preferred embodiment of a present invention.

Figure 8 is a schematic block diagram of a print device and sensor system in accordance with a preferred embodiment of a present invention.

Figure 9 is a schematic block diagram of a print device and sensor system in accordance with a preferred embodiment of a present invention.

Figure 10 is a schematic block diagram of a print device and sensor system in accordance with a preferred embodiment of a present invention.

## DETAILED DESCRIPTION

The following is a detailed description of the best presently known modes of carrying out the inventions. This description is not to be taken in a limiting sense, but is made merely for the purpose of illustrating the general principles of the inventions. Additionally, it is noted that detailed discussions of various internal operating components of image forming apparatus which are not pertinent to the present inventions, such as specific details of the image processing system, print control system, and interaction with a host computer, have been omitted for the sake of simplicity.

Although the present inventions are not limited to any particular image forming apparatus, the exemplary embodiments are described in the context of large format ink jet printers. The inventors herein have determined that one example of a conventional large format printer which could be reconfigured in such a manner that it would embody, incorporate or perform the present inventions is one of the Hewlett Packard DesignJet 2500 Series printers. Impact printers are another example of image forming apparatus to which the present inventions may be applied.

As illustrated for example in Figures 1 and 2, an image forming apparatus 100 in accordance with one embodiment of a present invention includes a housing 102 and a movable print device 104. The position of the print device 104 is monitored by a sensor system 106 which preferably includes a device having indicia that can be sensed, such as an encoder strip 108 with visible graduations, and at least two sensors 110a and 110b. The sensor system 106 is discussed in greater detail below. The exemplary housing 102 is provided with end portions 112 and 114, a window 116, a cover 118 that covers a print media roll (not shown), a receiving bin 120 and a shelf 122. The housing end portion 112 preferably encloses a scanning motor 124 that drives print device 104 back and forth over the print media 126 and a plurality of pen refill stations (not shown). The print media 126 is pulled through a slot 128 and carried by a roller 130 that is driven by a motor 132 in conventional fashion. The motor 132 and a printing element cleaning station (not shown) are located within the housing end portion 114. A control panel

134, including a display 136 and control buttons 138, is preferably supported on the exterior of the housing end portion 114.

The print device 104, sensor system 106, motors 124 and 132, and control panel 134 are connected to a printer controller 140 in conventional fashion in the exemplary embodiment. Suitable printer controllers include, for example, microprocessor based controllers. A clock 141 provides time information to the controller 140 which, when combined with position information from the sensor system 106, may be used to calculate the velocity and acceleration of the print device 104, which may in turn be used by the controller as it controls the operation of the print device. Generally speaking, the printer controller 140 receives image data from, for example, an application program, position data from the sensor system 106 and time information from the clock 141 as it controls the operation of the print device 104 and motors 124 and 132 to produce an image that corresponds to the image data. Additional aspects of the operation of the exemplary printer controller 140 are discussed in greater detail below.

Referring to Figure 3, the print device 104 in the exemplary image forming apparatus 100 includes a plurality of printing elements. Preferably, the print device 104 is provided with a plurality of ink jet pens 142 (sometimes referred to as "printhead cartridges," "pen cartridges" and "print cartridges") that are carried by a scanning carriage 144 in a formation referred to herein as a "bank." The pens 142 may, for example, be of the readily removable type that include a self-contained ink reservoir, the type that carry a small amount of ink and are refilled by tubes that connect the pens to a remote ink reservoir (in what is sometimes referred to as an "off-axis" system), or the type that are periodically moved to the remote ink reservoirs where they are filled (in what is sometimes referred to as a "take a gulp" system). A suitable pen for use in the exemplary embodiment is the Hewlett Packard Model No. C1806A pen for large format printers such as the aforementioned Hewlett Packard DesignJet 2500 Series printers. Such pens include nozzle plates 143 (Figure 5) with two columns of 124 nozzles (248 total nozzles).

Although the number of pens 142, the number of pen banks, and the arrangement of the pens within the bank(s) may vary to suit particular applications,

the exemplary embodiment illustrated in Figures 1-4 includes eight pens in a single bank. The number of pens 142 in a single bank can, however, vary from one to twelve, or even more if applications so require. The banks may be arranged such that each pen is aligned with the other pens (as shown), or such that one or more of the pens in the bank is offset (or "staggered") in the media axis from one or more of the other pens. Additionally, the pens 142 may be arranged such that the nozzle columns are either parallel to the media scan axis or diagonal to the media scan axis.

The exemplary scanning carriage 144, which reciprocatingly slides (or scans) on slide bearings back and forth along slider rods 146a and 146b (Figure 3) to define the carriage scan axis, consists primarily of a main body 148 having a plurality of pen slots 149 that respectively receive the pens 142. A pivotable latch 150 may be used to hold the pens 142 in place. A rear tray 152 carries electronic devices such as a pen interface printed circuit board. The electronic devices may also be mounted vertically or in other orientations. The scanning motor 124 is connected to the scanning carriage 144 in the exemplary embodiment by a drive belt 154 in conventional fashion. Other mechanisms for driving a scanning carriage, such as a motor and cable arrangement or linear motor, may be used if desired.

As noted above, and as illustrated for example in Figures 2-4, the exemplary image forming apparatus 100 includes a sensor system 106 that consists of a transparent linear encoder strip 108 and a pair of sensors 110a and 110b. More specifically, the graduations are sensed as the scanning carriage 144 moves to determine the position of the scanning carriage on the scan axis. A suitable sensor is a conventional light source and light sensor arrangement where light from the source is directed through the encoder strip and sensed by the sensor on the other side of the encoder strip. The position data, based on the number of graduations sensed as the scanning carriage 144 moves away from its home location, is used to determine the pen nozzle firing times (i.e. the times at which the nozzles eject ink) during each pass of the scanning carriage 144 over the print media 126. Preferably, the sensors 110a and 110b are located at the longitudinal ends of the scanning carriage 144 within respective sensor housings

156 (only one visible) and as close to the adjacent pens 142 as practicable. In one embodiment, the data from sensor 110a is used to control the nozzle firing times of the four closest pens 142, i.e. those identified with an "A" in Figure 4, while the data from sensor 110b is used to control the nozzle firing times of the other four pens, i.e. those identified with a "B." Position data from either one of the sensors 110a and 110b may be used in conventional fashion, with time information from the clock 141, for carriage motion control purposes.

In an alternate embodiment, data from the sensors 110a and 110b is combined and the controller 140 interpolates (and extrapolates, if necessary) positional data for locations between (or beyond) the sensors. Positional data for the location of each pen 142 is interpolated and used to individually control the firing the pens.

Depending on the configuration of the scanning carriage employed and other manufacturing constraints, the sensors 110a and 110b may be relocated in order to further reduce the distance between the sensors and the associated pens 142 or other printing elements. For example, the sensors 110a and 110b may be moved to the dash line positions shown in Figure 4. Additionally, the number of sensors 110a and/or 110b may also vary depending on the configuration of the associated scanning carriage, the size, number and type of pens (or other printing elements), and the desired level of printing accuracy as measured by, for example, dot placement error. Each pen could even have its own corresponding sensor if an application so required or, as described below with reference to Figure 8, a single pen could have more than one sensor associated therewith.

The present inventions are not limited to exemplary image forming apparatus illustrated in Figures 1-4. Turning to Figures 5 and 6, a print device 158 in accordance with another preferred embodiment includes two banks of pen slots with nozzle plate openings that allow the nozzle plates 143 to face the print media. The print device 158 may be reciprocatingly driven back and forth over print media by a motor and belt arrangement in the manner described above. The pens 142 are supported on a scanning carriage 160 that, in the exemplary embodiment, includes a main body 162 with two banks of six pen slots and a pair of slide bearings 164a and 164b that allow the carriage to slide along a pair of rails (not

shown). Two pen interface printed circuit boards 166a and 166b, i.e. one for each pen bank, are also provided.

With respect to carriage and, therefore, pen position sensing, the scanning carriage 160 in the exemplary embodiment illustrated in Figures 5 and 6 is preferably employed in image forming apparatus including sensor systems having at least two encoder strips 108a and 108b and at least two sensors 110a and 110b. To that end, the encoder strips 108a and 108b pass through a pair of sensor housings 168a and 168b that are positioned adjacent to the pen banks. The data from sensor 110a is used to control the nozzle firing times of the pens 142 identified with an "A" in Figure 6 and the data from sensor 110b is used to control the nozzle firing times of the pens identified with a "B."

The sensors 110a and 110b are preferably positioned at the midpoint of each bank of pens 142 in order to minimize the distance between the sensors and the farthest pens therefrom. Alternatively, as illustrated for example in Figure 7, a print device 158' that is otherwise identical to print device 158 is provided with four sensors 110a, 110b, 110c and 110d in order to further increase dot placement accuracy. The data from sensor 110a is used to control the nozzle firing times of the pens 142 identified with an "A," the data from sensor 110b is used to control the nozzle firing times of the pens identified with a "B," the data from sensor 110c is used to control the nozzle firing times of the pens 142 identified with an "C," and the data from sensor 110d is used to control the nozzle firing times of the pens identified with a "D." Another alternative, if possible given the scanning carriage configuration and manufacturing constraints, is to position the sensors 110a, 110b, 110c and 110d in the positions shown in dash lines in Figure 7.

The present inventions are also applicable to image forming apparatus in which print devices capable of printing relatively tall swaths are employed. As illustrated for example in Figure 8, an exemplary print device 170 may include one or more pens 172 or other printing elements on a carriage 174. The pens 172 are relatively tall and print a relatively tall swath (i.e. typically greater than one inch). In order to decrease the distance between the sensor system and the individual nozzles of the relatively tall pens 172, the exemplary print device 170 includes a sensor system consisting of at least two encoder strips 108a and 108b and at

least two sensors 110a and 110b. The encoder strips 108a and 108b pass through a pair of sensor housings similar to those discussed above with reference to Figure 5 and are positioned adjacent to the mid-line of the pen bank. Here, however, the sensors 110a and 110b are associated with particular nozzles, as opposed to particular pens. More specifically, data from sensor 110a is used to control the firing times of the nozzles in the portions of the pens 172 identified with an "A" and data from sensor 110b is used to control the firing times of the nozzles in the portions of the pens identified with a "B."

In other implementations of the present inventions, the positions of two or more locations on a movable print device may be monitored using devices other than encoder-based sensor systems. Here, one or more sensor devices are provided within the image forming apparatus and one or more fiducial reference points on the print device facilitate the sensing of position at two different locations on the print device. The fiducial reference points may be additional devices (i.e. "cooperative elements") mounted on the print device or readily identifiable portions of the print device itself such as shiny brackets.

As illustrated for example in Figure 9, an exemplary print device 176 may include one or more pens 142 or other printing elements on a carriage 178. Movement of the print device 176 is sensed by a laser interferometer system. Here, the laser interferometer system includes a pair of light source and sensor devices 180a and 180b that are mounted within the associated printing apparatus, preferably at one end of the scan axis, and a pair of reflectors 182a and 182b, preferably mirrors, that are carried in spaced relation on the carriage 178 and act as the fiducial reference points. The reflectors 182a and 182b may be located on the top, bottom or sides of the carriage 178. Light beams, including all suitable electromagnetic energy both in and out of the visible spectrum, emitted by the source and sensor devices 180a and 180b are reflected by the reflectors 182a and 182b back to the source and sensor devices in the manner illustrated in Figure 9 to individually determine how far the reflectors have moved from their respective original home locations. Data from sensor 180a is used to control the nozzle firing times of the pens 142 identified with an "A" and data from sensor 180b is used to control the nozzle firing times of the pens identified with a "B."

Additional source and sensor devices and reflectors may be provided as applications require. Moreover, the individual source and sensor devices 180a and 180b may be incorporated into a single device capable of providing and sensing more than one light beam and the individual spaced reflectors 182a and 182b may be incorporated into a single component capable of reflecting light from two different locations on the print device.

The laser interferometer sensor system described above with reference to Figure 9 may be incorporated into any of the print devices disclosed herein in place of, or in combination with, other sensor systems. For example, the print device 184 illustrated in Figure 10 includes a carriage 186 that supports two banks of six pen 142. Here too, a pair of light source and sensor devices 180a and 180b are mounted within the associated printing apparatus and a pair of reflectors 182a and 182b are carried in spaced relation on the carriage 186. Data from sensor 180a is used to control the nozzle firing times of the pens 142 identified with an "A" and data from sensor 180b is used to control the nozzle firing times of the pens identified with a "B."

The present apparatus and methods provide a number of advantages over conventional apparatus and methods. For example, obtaining position data at more than one location on a movable print device reduces the distance between respective portions of the print device and the associated sensor, thereby increasing the accuracy of the print device and reducing the likelihood of dot placement or other errors. Obtaining position data at more than one location on a movable print device also allows print devices that are manufactured with lower tolerances, lower cost materials and/or simplified manufacturing processes to achieve the same dot placement accuracy as those manufactured with tighter tolerances, higher cost materials and/or more complicated manufacturing processes. Additionally, in the event that an individual position sensing subsystem fails, position data from one or more other position sensing subsystems can be used to continue operation, albeit at a reduced level of performance.

Although the present inventions have been described in terms of the preferred embodiments above, numerous modifications and/or additions to the

above-described preferred embodiments would be readily apparent to one skilled in the art.

By way of example, but not limitation, relatively tall swaths may be formed using a print device that aligns two or more pens or other printing elements end to end instead of the relatively tall pen described above with reference to Figure 8. The present embodiments are also susceptible to use with a wide variety of sensors in addition to those described above and are not limited to encoder-based and laser interferometer systems. Other suitable sensor systems include photo-reflective encoder strip systems, magnetic encoder strip systems, triangulation sensor systems, magnetostrictive sensor systems, ultrasonic sensor systems, cable extension transducer systems, linear variable differential transformer systems, and digital camera systems. Additionally, sensors and/or fiducial reference points may be carried by some or all of the pens themselves, instead of being carried by the carriage.

Broadly, this disclosure has revealed an image forming apparatus having a position sensing device independently sensing the position of at least two locations on a movable print device.

It is intended that the scope of the present inventions extend to all such modifications and/or additions.

What is Claimed is:

1. An image forming apparatus, comprising:  
a movable print device (104, 158, 158', 170, 176, 184); and  
a position sensing device (106) for independently sensing position of at least first and second predetermined locations on the movable print device.
2. An image forming apparatus as claimed in claim 1, wherein the movable print device (104, 158, 158', 170, 176, 184) includes at least one ink jet pen (142) having a plurality of nozzles.
3. An image forming apparatus as claimed in claim 1, wherein the movable print device (104, 158, 158', 170, 176, 184) comprises a plurality of printer elements.
4. An image forming apparatus as claimed in claim 1, wherein the movable print device (104, 158, 158', 170, 176, 184) comprises a plurality of printer elements arranged in first and second banks.
5. An image forming apparatus as claimed in claim 1, further comprising:  
a controller (140), operably connected to the movable print device (104, 158, 158', 170, 176, 184) and the position sensing device (106), that controls a first portion of the print device at least partially in response to the position of the first location on the print device and controls a second portion of the print device at least partially in response to the position of the second location on the print device.
6. An image forming apparatus as claimed in claim 5, wherein the print device (104, 158, 158', 176, 184) includes at least first and second printer elements and the controller (140) controls the first printer element (A) at least partially in response to the position of the first location on the print device and controls the second printer element (B) at least partially in response to the position of the second location on the print device.

7. An image forming apparatus as claimed in claim 5, wherein the print device (170) includes a relatively tall printer element defining first and second longitudinal ends and the controller (140) controls a portion (A) of the printer element adjacent to the first longitudinal end at least partially in response to the position of the first location on the print device and controls a portion (B) of the printer element adjacent to the second longitudinal end at least partially in response to the position of the second location on the print device.

8. An image forming apparatus as claimed in claim 1, wherein the position sensing device (106) comprises a sensed device (108), having indicia that is capable of being sensed, positioned adjacent to the movable print device (104, 158, 158', 170) and at least first and second indicia sensors (110a and 110b) carried by the movable print device in spaced relation to one another.

9. An image forming apparatus as claimed in claim 8, wherein the sensed device comprises at least first and second sensed devices (108a and 108b) positioned in spaced relation to one another, the first indicia sensor (110a) is in a sensing relationship with the first sensed device, and the second indicia sensor (110b) is in a sensing relationship with the second sensed device.

10. An image forming apparatus as claimed in claim 1, wherein the position sensing device (106) comprises at least first and second fiducial reference points (182a and 182b) on the movable print device (176, 184) in spaced relation to one another and a fiducial reference point sensor (180a and 180b) that individually monitors the position of the first and second fiducial reference points.

11. An image forming apparatus as claimed in claim 10, wherein the first and second fiducial reference points (182a and 182b) comprise first and second reflectors and the fiducial reference point sensor (180a and 180b) directs individual beams of light at the first and second reflectors and senses reflected beams of light from the first and second reflectors.

12. An image forming apparatus for use with a movable print device, said apparatus having: a position sensing device, said sensing device being capable of independently sensing the position of said print device.

**AMENDED CLAIMS**

[received by the International Bureau on 14 February 2003 (14.02.03);  
original claims 1,6-8,10-11 amended ; original claims 5,9,12 cancelled;  
remaining claims unchanged (2 pages)]

1. An image forming apparatus, comprising:  
  
a movable print device (104, 158, 158', 170, 176, 184);  
  
a position sensing device (106) for independently sensing a position of at least a first predetermined location on the movable print device and for independently sensing a position of at least a second predetermined location on the movable print device; and  
  
a controller (140), operably connected to the movable print device (104, 158, 158', 170, 176, 184) and the position sensing device (106), that controls a first portion of the print device at least partially in response to the position of the first location on the print device and controls a second portion of the print device at least partially in response to the position of the second location on the print device.
2. An image forming apparatus as claimed in claim 1, wherein the movable print device (104, 158, 158', 170, 176, 184) includes at least one ink jet pen (142) having a plurality of nozzles.
3. An image forming apparatus as claimed in claim 1, wherein the movable print device (104, 158, 158', 170, 176, 184) comprises a plurality of printer elements.
4. An image forming apparatus as claimed in claim 1, wherein the movable print device (104, 158, 158', 170, 176, 184) comprises a plurality of printer elements arranged in first and second banks.
5. An image forming apparatus as claimed in claim 1, wherein the print device (104, 158, 158', 170, 176, 184) includes at least first and second printer elements and the controller (140) controls the first printer element (A) at least partially in response to the position of the first location on the print device and controls the second printer element (B) at least partially in response to the position of the second location on the print device.
6. An image forming apparatus as claimed in claim 1, wherein the print device (170) includes a relatively tall printer element defining first and second longitudinal ends and the controller (140) controls a portion (A) of the printer element adjacent to the first longitudinal end at least partially in response to the position of the first location on the print device and controls a portion (B) of the printer element adjacent to the second longitudinal end at least partially in response to the position of the second location on the print device.

7. An image forming apparatus, comprising:

a movable print device (104, 158, 158', 170, 176, 184);

a position sensing device (106) for independently sensing a position of at least a first predetermined location on the movable print device and for independently sensing a position of at least a second predetermined location on the movable print device;

wherein the position sensing device (106) comprises a sensed device (108), having indicia that is capable of being sensed, positioned adjacent to the movable print device (104, 158, 158', 170) and at least first and second indicia sensors (110a and 110b) carried by the movable print device in spaced relation to one another; and

wherein the sensed device comprises at least first and second sensed devices (108a and 108b) positioned in spaced relation to one another, the first indicia sensor (110a) is in a sensing relationship with the first sensed device, and the second indicia sensor (110b) is in a sensing relationship with the second sensed device.

8. An image forming apparatus as claimed in claim 1, wherein the position sensing device (106) comprises at least first and second fiducial reference points (182a and 182b) on the movable print device (176, 184) in spaced relation to one another and a fiducial reference point sensor (180a and 180b) that individually monitors the positions of the first and second fiducial reference points.

9. An image forming apparatus as claimed in claim 9, wherein the first and second fiducial reference points (182a and 182b) comprise first and second reflectors and the fiducial reference point sensor (180a and 180b) directs individual beams of light at the first and second reflectors and senses reflected beams of light from the first and second reflectors.

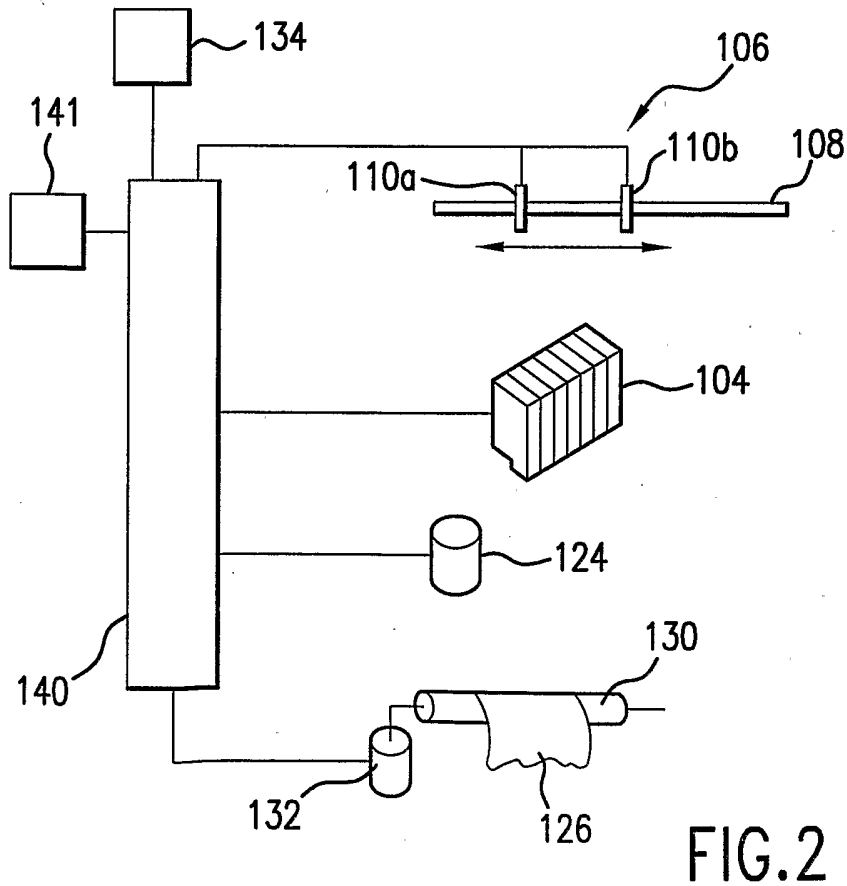
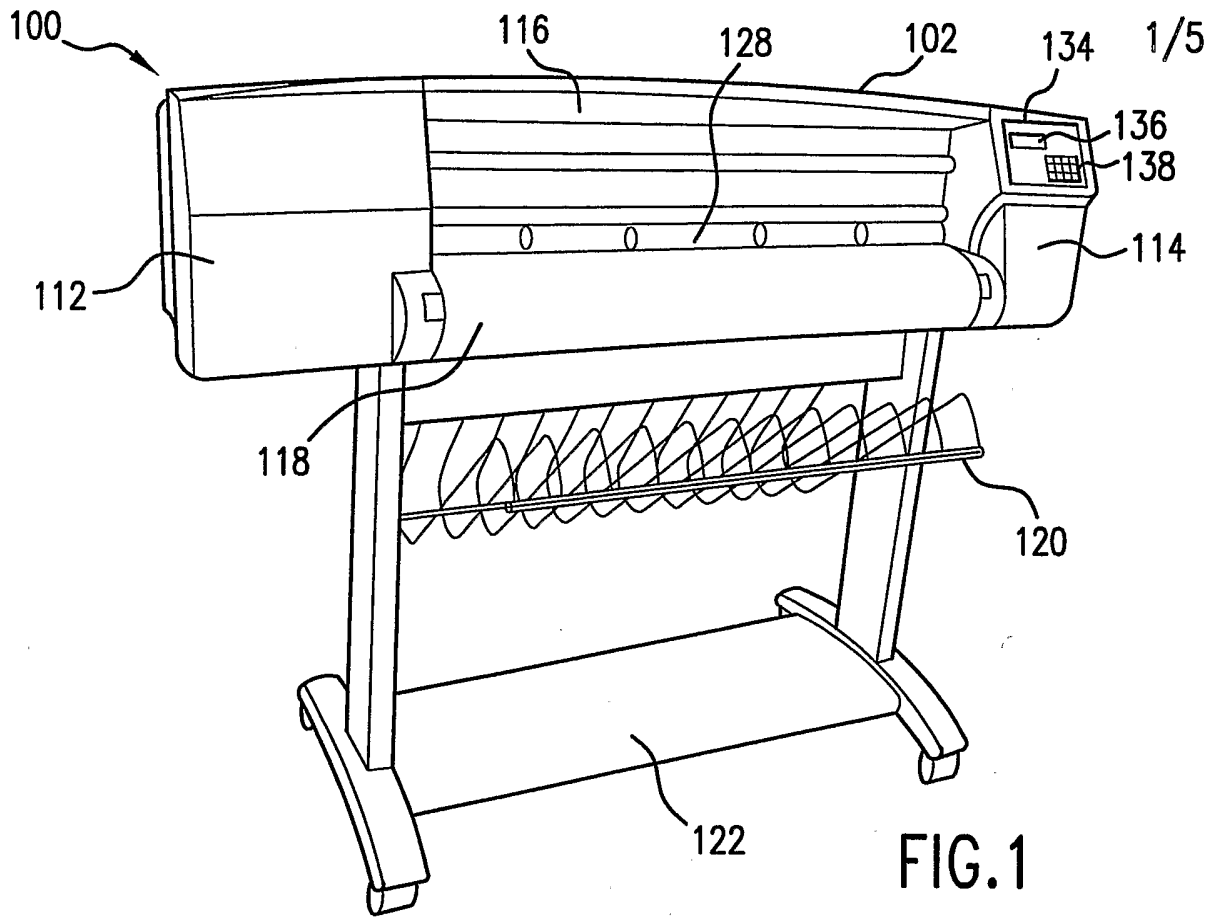

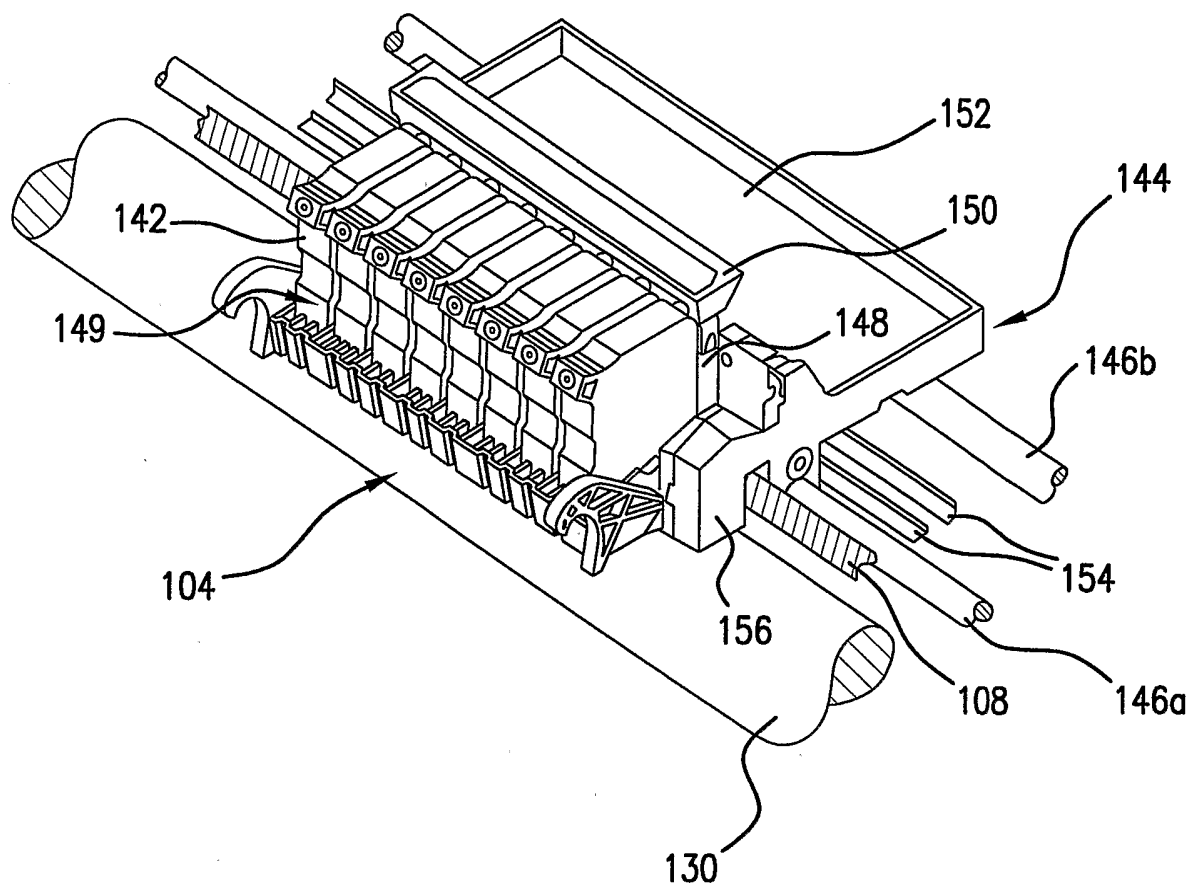

FIG. 3

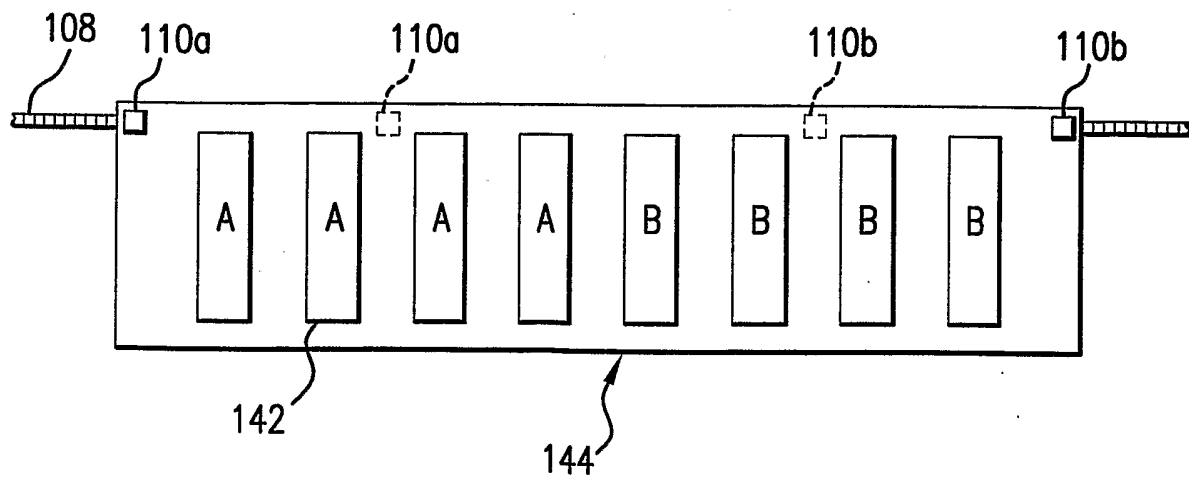

FIG. 4

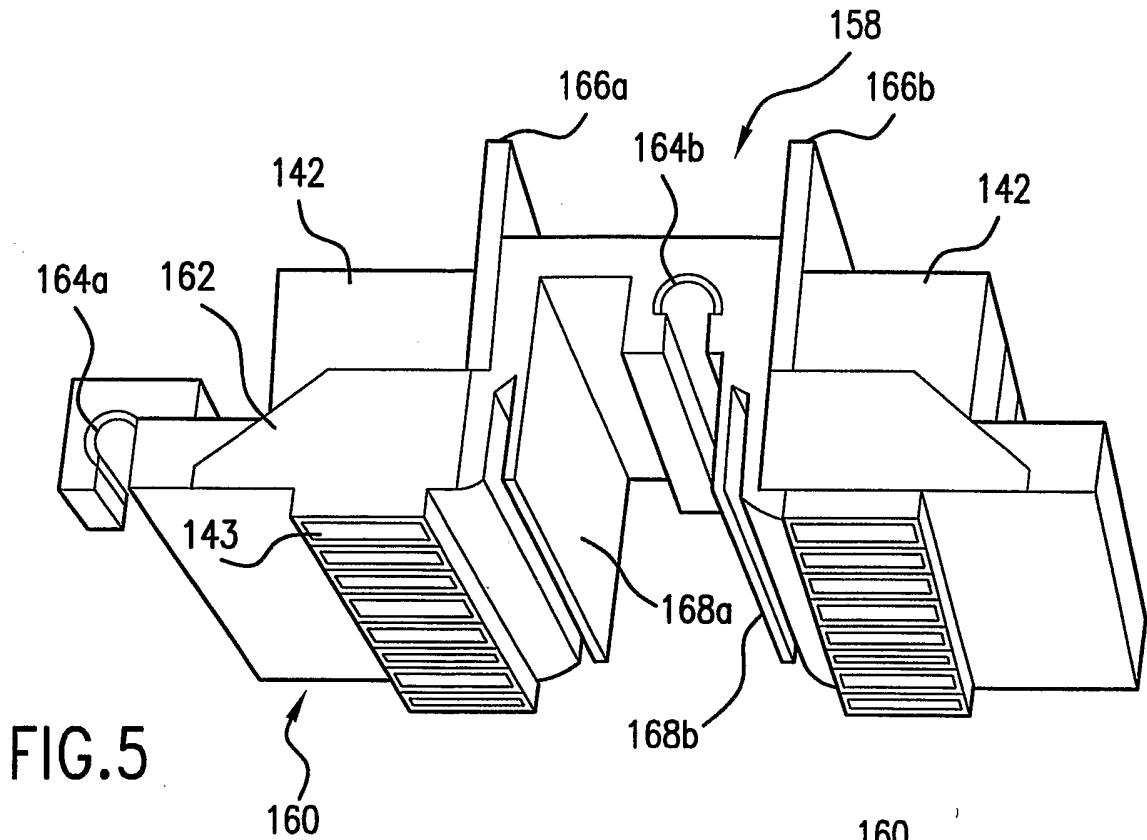

FIG. 5

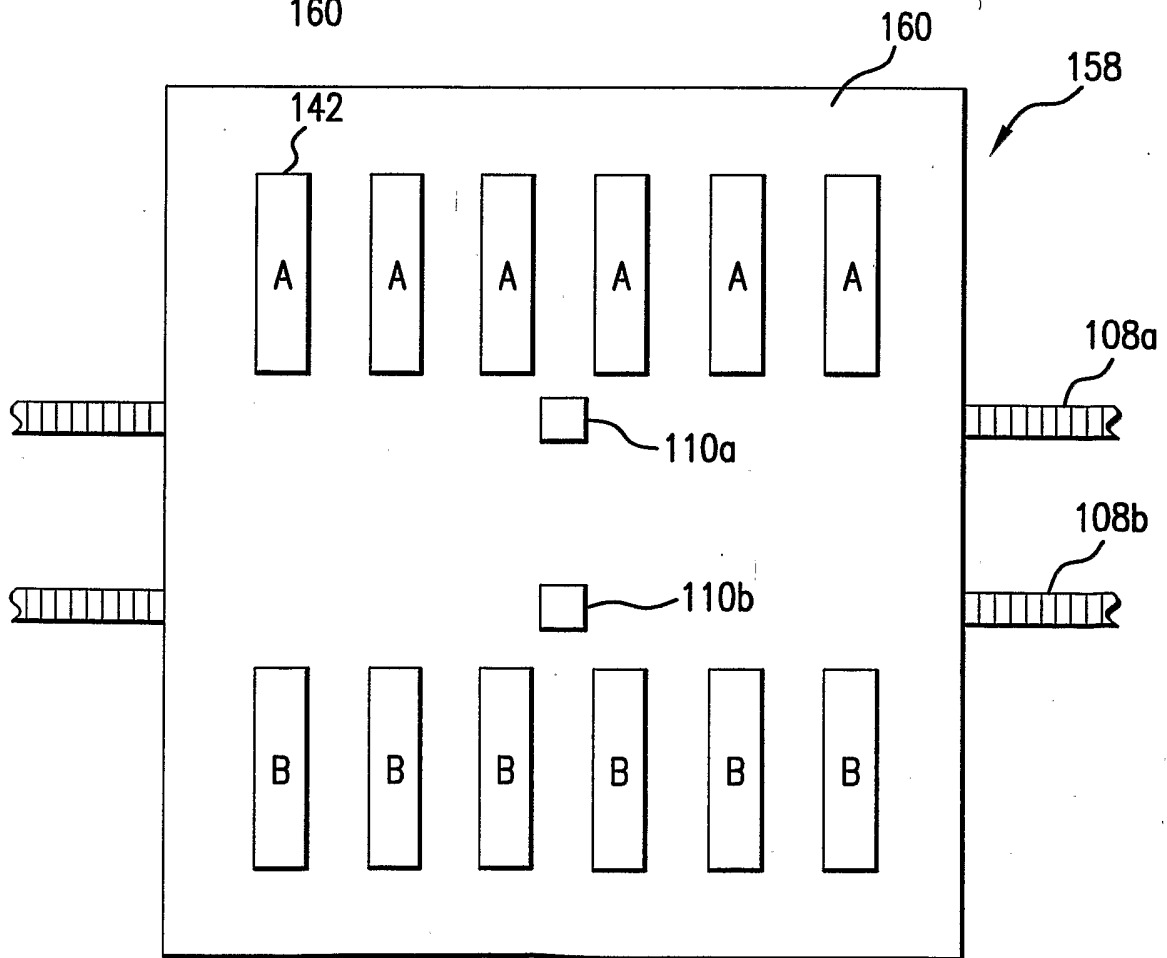

FIG. 6

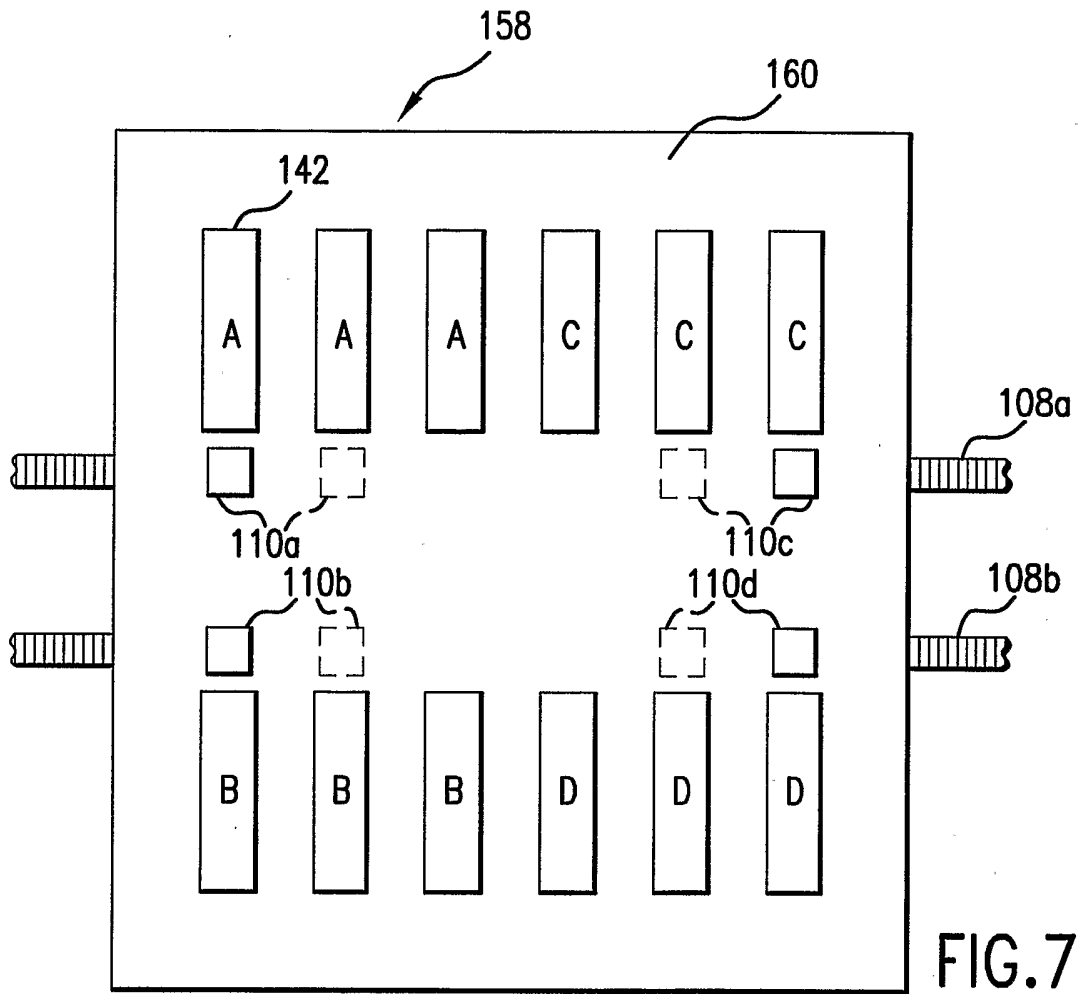

FIG. 7

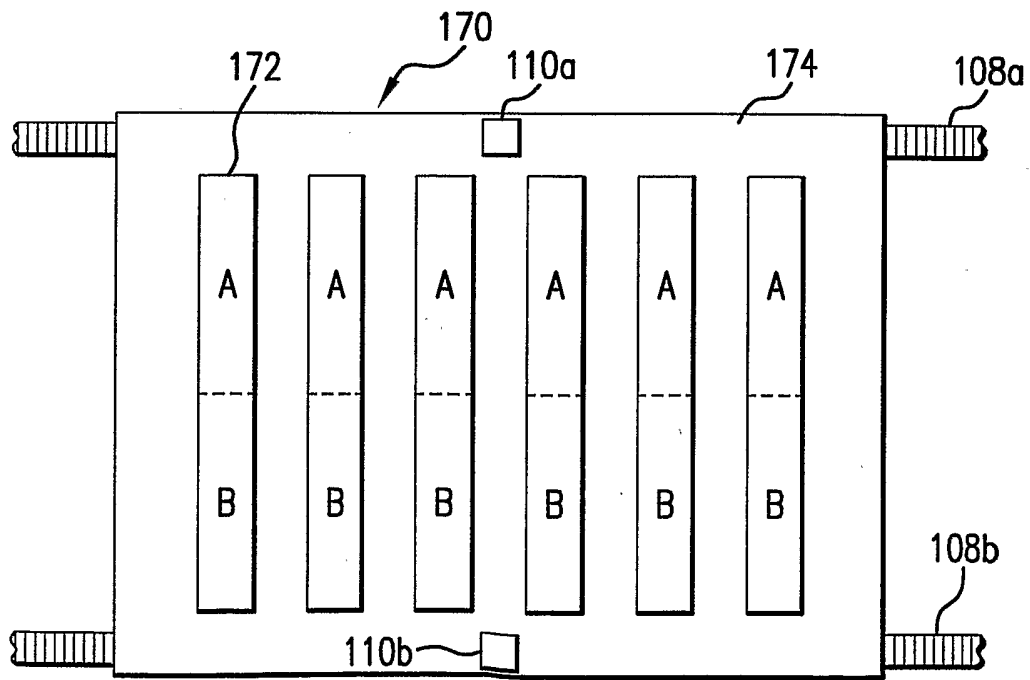

FIG. 8

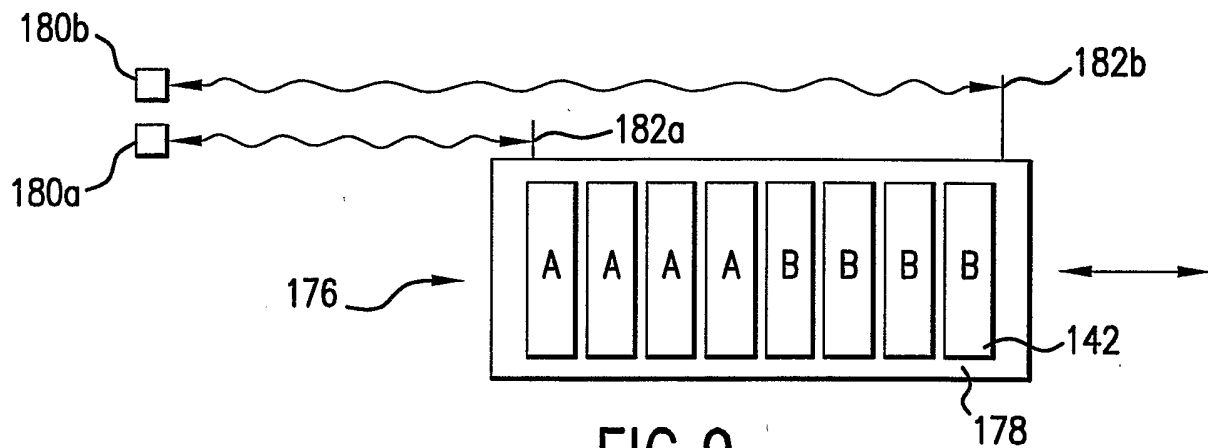

FIG. 9

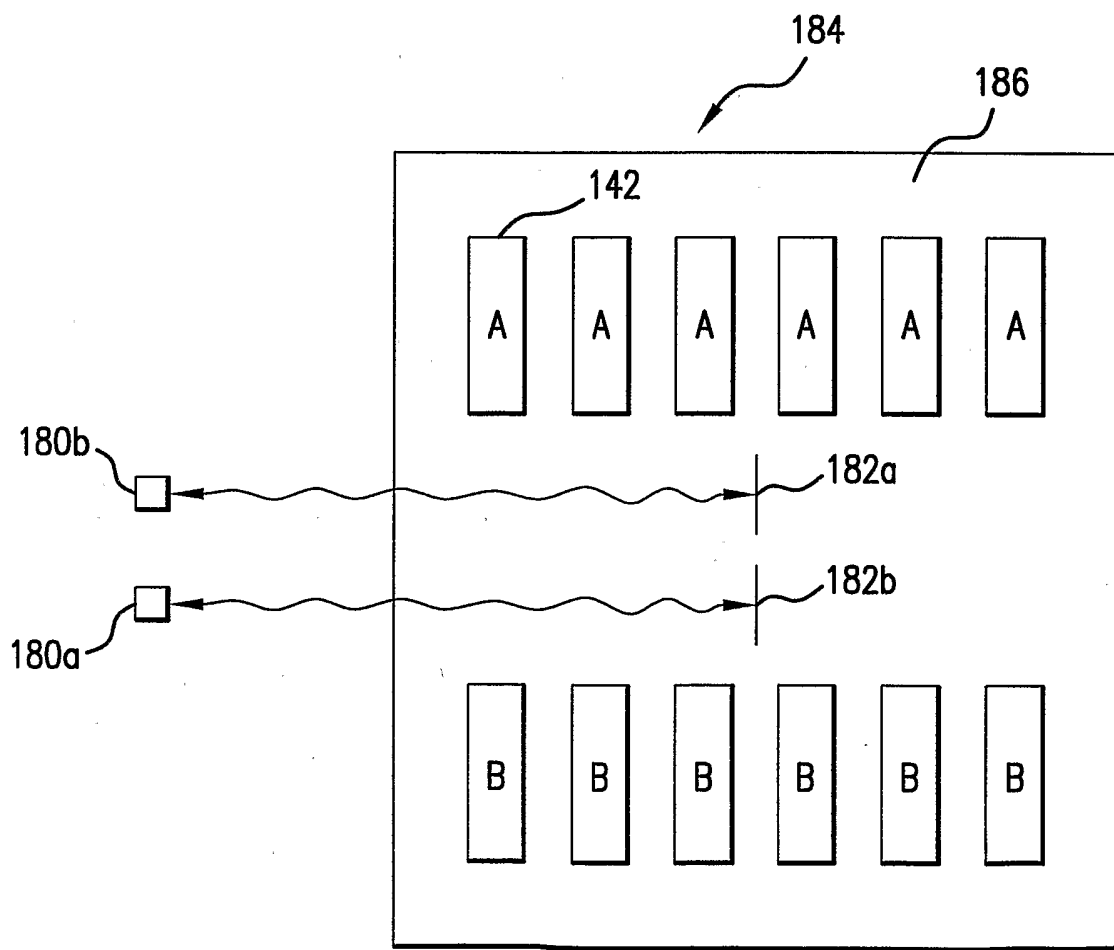

FIG. 10

INTERNATIONAL SEARCH REPORT

International Application No  
PCT/US 02/27927

A. CLASSIFICATION OF SUBJECT MATTER  
IPC 7 B41J19/20

According to International Patent Classification (IPC) or to both national classification and IPC

B. FIELDS SEARCHED

Minimum documentation searched (classification system followed by classification symbols)  
IPC 7 B41J

Documentation searched other than minimum documentation to the extent that such documents are included in the fields searched

Electronic data base consulted during the international search (name of data base and, where practical, search terms used)

EPO-Internal, PAJ, INSPEC, IBM-TDB, WPI Data

C. DOCUMENTS CONSIDERED TO BE RELEVANT

| Category ° | Citation of document, with indication, where appropriate, of the relevant passages   | Relevant to claim No. |
|------------|--|-----------------------|
| X          | WO 96 14989 A (LASERMASTER CORP)<br>23 May 1996 (1996-05-23)<br>page 40, line 26 -page 44, line 3; figure 18<br>page 27, line 28 -page 30, line 26; figure 12            | 1-4,8,9               |
| X          | ---<br>PATENT ABSTRACTS OF JAPAN<br>vol. 1997, no. 02,<br>28 February 1997 (1997-02-28)<br>& JP 08 282048 A (COPYER CO LTD),<br>29 October 1996 (1996-10-29)<br>abstract | 1-4,8,12              |
| A          | ---<br>US 6 232 594 B1 (STEINLE MICHAEL J ET AL)<br>15 May 2001 (2001-05-15)<br>column 3, line 5 -column 4, line 54;<br>figures 2,31<br>-----                            | 1                     |

Further documents are listed in the continuation of box C.

Patent family members are listed in annex.

° Special categories of cited documents:

- \*A\* document defining the general state of the art which is not considered to be of particular relevance
- \*E\* earlier document but published on or after the international filing date
- \*L\* document which may throw doubts on priority claim(s) or which is cited to establish the publication date of another citation or other special reason (as specified)
- \*O\* document referring to an oral disclosure, use, exhibition or other means
- \*P\* document published prior to the international filing date but later than the priority date claimed

- \*T\* later document published after the international filing date or priority date and not in conflict with the application but cited to understand the principle or theory underlying the invention
- \*X\* document of particular relevance; the claimed invention cannot be considered novel or cannot be considered to involve an inventive step when the document is taken alone
- \*Y\* document of particular relevance; the claimed invention cannot be considered to involve an inventive step when the document is combined with one or more other such documents, such combination being obvious to a person skilled in the art.
- \*G\* document member of the same patent family

Date of the actual completion of the international search

6 December 2002

Date of mailing of the international search report

16/12/2002

Name and mailing address of the ISA  
European Patent Office, P.B. 5818 Patentlaan 2  
NL - 2280 HV Rijswijk  
Tel. (+31-70) 340-2040, Tx. 31 651 epo nl,  
Fax: (+31-70) 340-3016

Authorized officer

De Groot, R

INTERNATIONAL SEARCH REPORT

Information on patent family members

International Application No  
PCT/US 02/27927

| Patent document cited in search report | Publication date | Patent family member(s) | Publication date         |
|--|------------------|-------------------------|--------------------------|
| WO 9614989                             | A                | 23-05-1996              | US 5751303 A 12-05-1998  |
|  |                  |                         | US 5592202 A 07-01-1997  |
|  |                  |                         | US 5805183 A 08-09-1998  |
|  |                  |                         | WO 9614989 A2 23-05-1996 |
| JP 08282048                            | A                | 29-10-1996              | NONE                     |
| US 6232594                             | B1               | 15-05-2001              | NONE                     |