



- (51) International Patent Classification: *A61M 25/09* (2006.01)
- (21) International Application Number: PCT/GB2014/052338
- (22) International Filing Date: 30 July 2014 (30.07.2014)
- (25) Filing Language: English
- (26) Publication Language: English
- (30) Priority Data:

1313567.8	30 July 2013 (30.07.2013)	GB
1406164.2	4 April 2014 (04.04.2014)	GB
- (71) Applicant (for all designated States except US): **THE QUEEN ELIZABETH HOSPITAL KING'S LYNN NHS FOUNDATION TRUST** [GB/GB]; Gayton Road, King's Lynn Norfolk PE30 4ET (GB).
- (72) Inventor; and
- (71) Applicant (for US only): **YOUNG, Peter** [GB/GB]; The Old Parsonage, Church Lane, Roydon, King's Lynn Norfolk PE32 1AR (GB).
- (74) Agent: **LEACH, Sean**; Mathys & Squire LLP, The Shard, 32 London Bridge Street, London, SE1 9SG (GB).
- (81) Designated States (unless otherwise indicated, for every kind of national protection available): AE, AG, AL, AM, AO, AT, AU, AZ, BA, BB, BG, BH, BN, BR, BW, BY, BZ, CA, CH, CL, CN, CO, CR, CU, CZ, DE, DK, DM, DO, DZ, EC, EE, EG, ES, FI, GB, GD, GE, GH, GM, GT, HN, HR, HU, ID, IL, IN, IR, IS, JP, KE, KG, KN, KP, KR, KZ, LA, LC, LK, LR, LS, LT, LU, LY, MA, MD, ME, MG, MK, MN, MW, MX, MY, MZ, NA, NG, NI, NO, NZ, OM, PA, PE, PG, PH, PL, PT, QA, RO, RS, RU, RW, SA, SC, SD, SE, SG, SK, SL, SM, ST, SV, SY, TH, TJ, TM, TN, TR, TT, TZ, UA, UG, US, UZ, VC, VN, ZA, ZM, ZW.
- (84) Designated States (unless otherwise indicated, for every kind of regional protection available): ARIPO (BW, GH, GM, KE, LR, LS, MW, MZ, NA, RW, SD, SL, SZ, TZ, UG, ZM, ZW), Eurasian (AM, AZ, BY, KG, KZ, RU, TJ, TM), European (AL, AT, BE, BG, CH, CY, CZ, DE, DK, EE, ES, FI, FR, GB, GR, HR, HU, IE, IS, IT, LT, LU, LV, MC, MK, MT, NL, NO, PL, PT, RO, RS, SE, SI, SK, SM,

[Continued on next page]

(54) Title: MEDICAL GUIDE WIRE

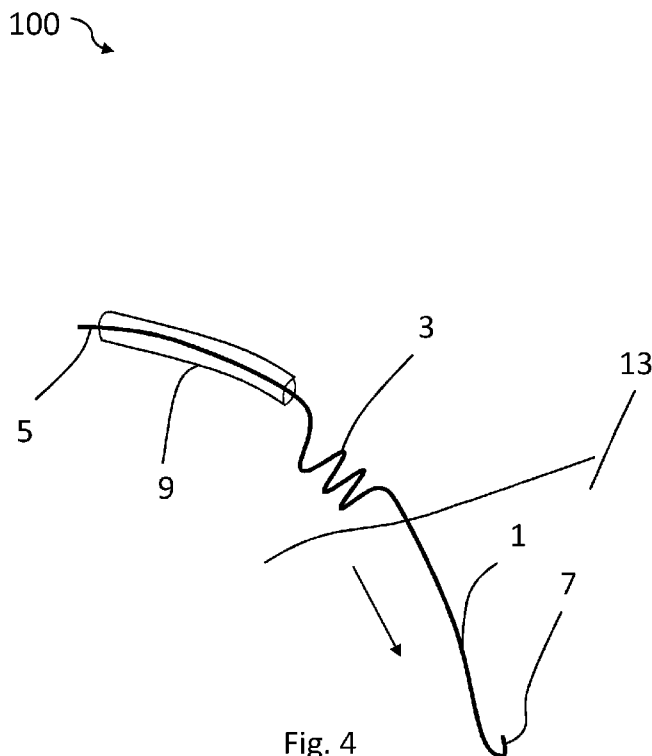

Fig. 4

(57) **Abstract:** A medical guide wire (100) for assisting placement of a tube into a patient is provided. The guide wire comprises a first section (1), a mid-section (3) configured to be straightened from an original shape to a straightened shape, and a second section (5) configured to protrude out of the tube when the tube reaches the mid-section during placement. In the original shape the mid-section comprises at least one of a curve bend or a kink configured to indicate to the operator to stop feeding the first section into the patient and to discourage guide wire retention in the tube by allowing the second section to protrude out of the tube when the tube reaches the mid-section. In the straightened shape, the mid-section is configured to allow the tube to pass along the mid-section and into the patient.



TR), OAPI (BF, BJ, CF, CG, CI, CM, GA, GN, GQ, GW, KM, ML, MR, NE, SN, TD, TG). **Published:**

— *with international search report (Art. 21(3))*

Medical Guide Wire

Field of the invention

The present disclosure relates to a medical guidewire for assisting placement of a tube
5 into a patient.

Background

Currently guide wires are used for the placement of venous catheters, arterial catheters,
chest drains and the like. For example central venous catheter guide wires are
10 commonly passed through a needle or short catheter into the vein, the needle or short
catheter is removed, a dilator may be passed and removed to open up the channel and
then the longer central venous line passed over the guide wire into position. The guide
wires commonly have atraumatic tips of a flexible material and/or a short curved section
at the tip so that when the wire is advanced there is soft material and/or a blunt curve of
15 wire at the leading tip. There are some major problems associated with the placement of
these wires.

Firstly, if the wire is placed too far into the vein, it can go into the heart and cause trauma
or rhythm disturbances. The wire is commonly kept short and/or a marking is put onto the
20 wire to indicate depth of placement to avoid this problem. Secondly, the wire can be
accidentally left in the central venous catheter. This can cause a serious and potentially
fatal condition if the wire moves forward into the bloodstream or other body cavity. This is
more likely to happen if the wire is shorter as the catheter is more likely to fully cover the
wire and the clinician placing the catheter can forget to remove it. Thirdly, if the wire is
25 too long it becomes difficult to handle and may become contaminated if it touches things
outside of a sterile area. These principles also apply to chest drains and other wire-
based catheter placement devices.

Summary of the invention

30 The current invention is a medical guide wire, with or without an atraumatic tip, that is
designed to avoid accidental retention in the catheter, body cavity or bloodstream. Ideally
the current invention guide wire is twice as long or greater than twice as long as the
catheter that it is guiding. There are one or more curves, bends or kinks in the current

- 2 -

invention guide wire along its length. This makes the invention more compact and easy to handle for the operator, being less likely to touch the operator's body or outside of the sterile field.

5 Additionally the bend or bends in the wire indicate to the operator the depth of insertion of the wire into the body cavity or bloodstream.

Advantageously, the bend or bends in the wire also prevent the catheter being inserted too far along the guidewire, and the length of the guidewire being longer than the
10 catheter discourages guidewire retention by ensuring that an end of the catheter is visible to the operator.

In one aspect there is provided a medical guidewire for assisting placement of a tube into a patient, comprising:

- 15 a first section;
a mid-section being configured to be straightened from an original shape to a straightened shape; and
a second section configured to protrude out of the tube when the tube reaches the mid-section during the placement;
- 20 wherein
in the original shape the mid-section comprises at least one of a curve bend or a kink configured to indicate to the operator to stop feeding the first section into the patient and to discourage guidewire retention in the tube by allowing the second section to protrude out of the tube when the tube reaches the mid-section; and
- 25 in the straightened shape, the mid-section is configured to allow the tube to pass along the mid-section and into the patient.

Straightening the mid-section may comprise straightening the mid-section to such a degree that the tube can pass uninhibited along the mid-section. The straightened
30 shape may still comprise a slight bend or curve.

The first section may be located at a distal end of the guidewire and the second section may be located at a proximal end of the guidewire, and the guidewire may be configured

to:

straighten when each end is held and the wire is pulled, and reform into its original shape when released.

5 At least one of the first section and the second section may be arranged to form a substantially straight configuration. It will be understood that a substantially straight configuration may comprise a slight bend or curve.

The mid-section may be arranged to operate in two configurations, wherein:

- 10 in the first configuration, corresponding to the original shape, the mid-section is configured to form a shape for inhibiting insertion of the guidewire into the patient and inhibiting insertion of the tube over the mid-section of the guidewire into the patient; and
- in the second configuration, corresponding to the straightened shape,
- 15 mid-section is configured to form a shape for allowing insertion of the tube over the guidewire and into the patient.

In the first configuration or original shape, the mid-section may comprise at least one of: a spiral, a helix, a coil, a curve, a bend that doubles back on itself with an acute angle or

20 a kink. The mid-section may comprise a u-shaped bend, or a v-shaped angle of between 0 and 150 degrees. The helix may form at least one complete revolution. The turns of the helix may increase in diameter to form a conical shape.

The mid-section may be resiliently deformable such that upon the application of a pulling

25 force it can be straightened from the first configuration to the second configuration, but will return to its original shape being the first configuration when released.

The tube may be configured to supply a fluid or remove a fluid from the patient. The tube may comprise at least one of a venous catheter, an arterial catheter and a chest drain.

30

The first section may be at least as long as an introduction funnel (such as a needle or short catheter) through which the first section is configured to be passed during placement of the tube into the patient. The first section may be at least twice as long as

an introduction funnel through which the first section is configured to be passed during placement of the tube into the patient. The guidewire may be at least twice as long as the tube. The second section may be at least twice as long as the tube. The first section and/or the mid-section may be longer than the tube.

5

The guidewire may comprise an atraumatic tip. The atraumatic tip may be located at a distal end of the guidewire. The second section may be arranged to form a curve, bend or kink configuration at the proximal end of the guidewire.

10 The second section may be arranged to form at least one of a spiral, a helix, a curve, a bend that doubles back on itself with an acute angle or a kink. Advantageously, this may prevent the second section from becoming de-sterilised, for example by touching the floor, during insertion into the patient. The second section may be arranged to comprise no curve bends or kinks, or a number of curve bends or kinks.

15

At least one of the first section, the mid-section and the second section of the guidewire may be resiliently deformable.

The guidewire may comprise a core of material having a shape memory and a sheath of
20 biocompatible material. For example, the core may comprise Nitinol.

The guidewire may comprise at least one of a change in colour and a change in diameter between at least two sections of the guidewire.

25 In another aspect there is provided a cassette for a medical guidewire comprising:

a storage tube;

a cone portion;

a feeding member adapted to feed the guidewire from the storage tube into the cone portion, and;

30 a guidewire accommodated in the tube.

The storage tube of the cassette may be arranged to operate in a spiral configuration when accommodating the guidewire. The guidewire may be stored in the cassette in the

straightened shape or second configuration but will reform to its original shape or first configuration when released from the cassette.

In another aspect there is provided a medical kit comprising:

- 5 a guidewire;
 a tube for supplying a fluid or removing a fluid from a patient; and
 a cover sealing the guidewire and the tube.

The medical kit may further comprise a needle or cannula for inserting a portion of the
10 guidewire into the patient and a cassette for the guidewire. The cover may be configured to provide a sterile environment. The cover may be configured to seal the guidewire and/or the tube so that they remain sterile.

In another aspect there is provided a method of manufacturing a medical guidewire,
15 comprising:

- obtaining a length of wire having a shape memory;
 heating the wire on a jig or mandrel to give a portion of the wire a memory for a shape different to that of the remaining portions of the wire;
 coating the wire in a biocompatible material.

20

In another aspect there is provided a method of placing a tube into a patient, comprising:

 providing a medical guidewire comprising a first section, a mid-section configured to be operated from an original shape to a straightened shape, wherein in the original shape the mid-section comprises at least one of a curve bend or a kink, and a second
25 section;

- providing a tube for insertion into the patient;
 inserting the first section of the guidewire into the patient;
 applying a force to the guidewire to cause it to be straightened from the original shape to the straightened shape; and

30 feeding the tube along the mid-section and into the patient.

Applying a force to the medical guidewire may comprise holding two portions of the guidewire either side of the mid-section and pulling on the guidewire. Inserting a portion

- 6 -

of the medical guidewire may comprise inserting the first section of the guidewire into the patient until the mid-section abuts the patient.

The second section may be configured to protrude out of the tube when the tube reaches 5 the mid-section during the placement. The method may further comprise feeding the tube onto the guidewire before the force is applied to the guidewire.

Providing the guidewire may comprise providing the guidewire in a cassette wherein the guidewire is configured to be stored in the cassette in the straightened shape but will 10 reform to its original shape when released from the cassette.

The cassette may comprise:

a storage tube for storing the guidewire;

a cone portion configured to be coupled to a funnel for inserting the guidewire into 15 the patient; and

a feeding member adapted to feed the guidewire from the storage tube into the cone portion by an operator running their thumb along the feeding member and an exposed portion of the guidewire.

20 Providing the guidewire and providing the tube may comprise providing the guidewire and the tube in a medical kit with a cover sealing the guidewire and the tube.

The method may further comprise providing the guidewire in a cassette, wherein the guidewire is configured to be stored in the cassette in the straightened shape but will 25 reform to its original shape when released from the cassette.

Drawings

Embodiments of the disclosure will now be described, by way of example only, with reference to the accompanying drawings, in which:

30

Fig. 1 shows an example medical guidewire in a first configuration corresponding to its original shape;

Fig. 2 shows the example medical guidewire of Fig. 1 in a straightened shape or second

- 7 -

configuration;

Fig. 3 shows the example medical guidewire of Figs. 1 and 2 ready to be inserted into a patient;

Fig. 4 shows the example medical guidewire of Fig. 3 inserted into a patient;

5 Fig. 5 shows the example medical guidewire of Fig. 4 in a second configuration corresponding to a straightened shape;

Fig. 6 shows the example medical guidewire of Figs. 1 to 5 stored in a cassette;

Fig. 7 shows a medical kit comprising the example medical guidewire of Figs. 1 to 6;

Figs. 8A, 8B and 8C show further examples of the mid-section of an example medical
10 guidewire;

Fig. 9 shows another example of a medical guidewire having a curved or bent second section.

Specific description

15 This invention relates to a modification of a medical guide wire designed to assist placement of medical catheters into body cavities.

The guide wire can be described as having:

1. an advancing tip which may be atraumatic,
- 20 2. a first section in continuity with the tip which is flexible and without kinks, bends or curves and is at least as long as the needle or cannula through which it is passed during placement,
3. a first curve bend or kinked section in continuity with the first section which can be straightened substantially to allow a catheter to slide over it,
- 25 4. a second section with either no or a number of curve bends or kinks or another shaped wire pathway so as to allow loading of the catheter but to form a more convenient shape to keep the second section from protruding excessively thereby impeding the operator or being inconvenient for the operator or being more likely to become contaminated. Additionally the second section is longer than the catheter that it
30 is designed to guide.

The present invention wire as a whole will straighten out easily when each end is held and the wire is pulled and will reform into its original shape when released. This allows a

catheter to pass easily along the wire but the wire regains its shape to once the catheter passes beyond the bend, kink or curve.

One preferred embodiment of the invention is a guide wire with an atraumatic tip, a first section which exactly the length of the catheter which it is designed to guide, a first curve which doubles the catheter substantially back upon itself (a preferred embodiment has a v shaped angle of 0 to 150 degrees) and a second section which is straight and at least one centimetres longer than the catheter which it is designed to guide. During placement with this embodiment the operator would pass the tip and first section of the wire through an introduction cannula or needle. The first curve would indicate to the operator to stop feeding the wire and so over insertion would be avoided. The introducing needle or cannula would be removed. A dilator may be passed along the wire then removed now if desired. The catheter would then be passed along the second section of the guide wire. When the tip of the catheter reaches the first curve the second section of the guide wire will protrude out of the catheter (by at least one centimeter in this embodiment) and this will discourage guide wire retention in the catheter or embolisation of the wire. The catheter can then be threaded over the first curve and into the body cavity or blood vessel.

Another preferred embodiment of the invention is a guide wire with an atraumatic tip, a first section which exactly the length of the catheter which it is designed to guide, a first curve which leads directly and is in continuity with a second section which is spiralled and at least one longer than the catheter which it is designed to guide. During placement with this embodiment the operator would pass the tip and first section of the wire through an introduction cannula or needle. The first curve and spiralled second section would indicate to the operator to stop feeding the wire and so over insertion would be avoided. The introducing needle or cannula would be removed by threading over the spiralled second section. A dilator may be passed along the wire then removed now if desired. The catheter would then be passed along the spiralled second section of the guide wire. When the tip of the catheter reaches the first section, the second section of the guide wire will protrude out of the catheter (by at least one centimetre in this embodiment) and this will discourage guide wire retention in the catheter or embolisation of the wire. The catheter can then be threaded over the first curve and into the body cavity or blood

vessel.

Many other embodiments are possible.

5 The invention ensures that the curves, bends or kinks in the mid-section of the wire indicate to the operator to discourage over-insertion and make wire retention unlikely as the first curve or second section will never be placed into the patient and therefore the second section will always protrude out of the proximal (near the operator) catheter end before the distal (patient end) enters the patients tissues.

10

One embodiment of the invention has curves, bends or kinks at the proximal (operator) end of the second section so that a preformed shape reforms when the wire end protrudes from the proximal end of the second section as the distal catheter tip approaches the first section of the guide wire.

15

Fig. 1 shows an example medical guidewire 100. The guidewire 100 comprises a first section 1, a mid-section 3 and a second section 5. The first section 1 is at the distal end of the guidewire 100 and the second section 5 is at a proximal end of the guidewire. The mid-section 3 is located between the first section 1 and the second section 5. The
20 guidewire 100 further comprises an atraumatic tip 7 at the distal end of the guidewire. The atraumatic tip 7 is in the form of a "J-tip". The atraumatic tip 7, the first section 1, the mid-section 3 and the second section 5 are all in continuity. In the example shown, the mid-section 3 forms a helix shape. The guidewire 100 comprises a core of Nitinol having a shape memory, wrapped in a biocompatible sheath, for example PTFE.

25

The atraumatic tip 7, the first section 1, the mid-section 3 and the second section 5 are resiliently deformable. Accordingly, the guidewire 100 is resiliently deformable. The guidewire 100 is configured to be straightened from an original shape, or a first configuration, to a straightened shape, or a second configuration, by holding each end or
30 two portions of the guidewire 100 either side of the mid-section 3, and applying a pulling force, as shown in Fig. 2. The guidewire 100 is configured to reform its original shape or return to the first configuration when the guidewire 100 is released.

- 10 -

In operation, to insert the guidewire 100 into a patient, the operator first passes a needle 11 (or any other device forming a funnel, such as a cannula or a short catheter) into the body 13, as shown in Fig. 3. The needle 11 acts as a funnel for the tip 7 and the first section 1 of the guidewire 100, so that the operator can feed the first section 1 of the 5 guidewire 100 into the patient, as shown in Fig. 4. The guidewire 100 is inserted into the patient until the mid-section 3 abuts the needle 11, for example a proximal end of the needle 11. The shape or morphology of the mid-section 3 in its original shape or first configuration is configured to inhibit further insertion of the guidewire 100 into the patient, by forming an elbow and/or a change of direction between the first section 1 and the mid- 10 section 3. The needle 11 is removed by sliding it along the guidewire 100 and over the mid-section 3, for example after having straightened the mid-section 3.

Once the needle is removed a catheter 9 is fed along or over the second section 5 of the guidewire 100 until it abuts the mid-section 3, for example a helix of the mid-section 3. In 15 some examples this happens when a distal tip of the catheter abuts the mid-section 3. The shape or morphology of the mid-section 3 in its original shape or first configuration is configured to inhibit further movement of the catheter 9 over the guidewire 100. The second section 5 is configured such that it is longer than the catheter 9 which is to be inserted into the patient. As shown in Fig. 4, in this way, the proximal end of the 20 guidewire 100, for example the second section 5, is still exposed when the catheter 9 is fed onto the second section 5 of the guidewire 100 abutting the mid-section 3. Because the proximal end of the guidewire 100 is exposed, the operator can not only effectively pull on the guidewire 100 to straighten it, but the operator is also discouraged from guidewire retention as the operator is reminded of the guidewire's presence.

25

The operator can then hold two ends or portions of the guidewire 100 as described above, and pull on the guidewire 100, as shown in Fig. 5. For example, the operator will pull on the proximal end 500 of the guidewire 100 and a distal end 550 of the guidewire 100 that is still exposed, for example above and adjacent to the surface of the patient's 30 skin. Pulling on the guidewire 100 in this way straightens the guidewire 100 from its original shape, or first configuration, to a straightened shape, or a second configuration. As shown in Fig. 5, by straightening the guidewire 100 in this way, the operator can slide the catheter 9 over the mid-section 3 of the guidewire 100 and into the patient. It will be

understood that by straightening the guidewire 100, it is not necessary that the mid-section 3 of the guidewire 100 is necessarily rectilinearly straight. For example, in some configurations when the mid-section 3 is straightened, the guidewire 100 itself may have a slight curve or bend, but the mid-section 3 will be straightened in such a way that it reduces the degree to which insertion of the guidewire 100 and insertion of the catheter 9 is inhibited. For example, if the mid-section 3 comprises a kink, straightening the mid-section 3 may comprise "unkinking" the mid-section 3 of the guidewire 100.

Once the catheter 9 has been slid over or along the mid-section 3 of the guidewire 100, the operator can release the guidewire 100 and it will return to its original shape corresponding to the first configuration.

In some configurations, the guidewire 100 is either supplied in a cassette 200 or fed into the patient via the needle 9 from a cassette 200, as shown in Fig. 6. The cassette 200 comprises a tube portion 201, a cone portion 203 and a feeding member 205. The cone portion 203 may be coupled to the needle 11 for insertion of the guidewire 100 into the patient. An operator can feed the guidewire 100 from the cassette 200 by running their thumb along the feeding member 205 and over the exposed portion of the guidewire 100. The cassette 200 further has a retaining member 207 linking a distal end of the tube portion 201 to the cone portion 203, so that the tube 201 and hence the guidewire 100 is stored in a spiral shape, and hence takes up less space when stored.

In these configurations, the guidewire 100 is stored such that the mid-section 3 is in the straightened or second configuration in the tube portion 201, but when released from the cassette 200 the mid-section 3 of the guidewire 100 will reform its original shape corresponding to the first configuration.

In some configurations, the guidewire 100 is supplied as part of a medical or surgical kit or apparatus comprising a sealed sterile pack 300, as shown in Fig. 7. The sealed sterile pack 300 may have a cover that covers the contents of the pack 300 so that they remain sterile. The pack 300 may comprise the guidewire 100, and the guidewire 100 may be stored in a cassette 200. The pack 300 may further comprise a funnel or needle 303 for inserting a portion of the guidewire 100 into a patient, and a catheter 309 or a range of

catheters.

In some configurations the guidewire 100 has a different tip 7. For example, in some configurations the guidewire 100 may comprise a steerable tip, a sharpened tip, a rounded tip or a soft tip. In some configurations the tip 7 of the guidewire has no modifications.

As already mentioned, the mid-section 3 of the guidewire 100 may be configured to form any shape or morphology, such as an elbow or change of direction of extension with respect to the first section 1 and/or the second section 5, that creates a discontinuity of extension. For example, the mid-section 3 may comprise a portion that extends in a direction transverse to that of the first section 1 and/or the second section 5. For example, a longitudinal axis of the mid-section 3 may extend in a direction different, for example transverse to, that of a longitudinal axis of the first section 1 and/or the second section 5.

The shape or morphology may be configured to inhibit insertion of the guidewire 100 into a patient by abutment, and inhibit insertion of a catheter 9 over the guidewire 100 by abutment. In other words, the shape or morphology of the mid-section 3 may be configured such that it inhibits further insertion of the guidewire 100 into the patient due to its shape or morphology coming into contact with a portion of the patient, for example their skin, and also inhibits insertion of the catheter 9 over the guidewire 100 by coming into contact with a distal end of the catheter 9. For example, because the catheter 9 is relatively stiff, and the shape or morphology of the mid-section 3 may comprise a change in direction of extension of the guidewire 100, the catheter 9 cannot bend sufficiently to easily slide over the mid-section 3 and accordingly the mid-section 3 inhibits insertion of the catheter over the guidewire 100. In this way the mid-section 3 may act as a stop for both catheter 9 but also for insertion into the patient.

For example, the mid-section 3 may be configured to form any one of a helix, a spiral, a curve, a bend, a kink, a coil or any other shape or morphology as shown in Figs. 8A to 8C. It will be understood that the term "kink" may include an axial twist of the guidewire 100. In some configurations, the mid-section 3 may be configured to form a plurality of

shapes, for example a plurality of kinks as shown in Figs. 8A and 8B, or a bellows. The mid-section 3 may be configured to form a shape that passes through an angle of at least 90 degrees, at least 180 degrees, at least 360 degrees, at least 720 degrees. For example, if the shape is a spiral, the spiral may be configured to make at least one or at 5 least two complete revolutions as shown in Fig. 8C. As another example, the mid-section 3 may form a u-shaped bend, or a v-shaped angle of between 0 and 150 degrees, for example between 0 and 90 degrees, for example the mid-section 3 may form a v-shaped angle that doubles back on itself. The mid-section 3 may be configured to form a shape with an acute angle. In some configurations the mid-section 3 may be 10 configure to form a "pig-tail" shape. For example, the mid-section 3 may comprise at least four helical turns or folds. The helical turns or folds may have, for example, at least a one centimetre diameter. The helical turns or folds may increase in diameter such that the mid-section forms a conical shape.

15 The guidewire 100 may be manufactured from any material, but preferably comprises at least a portion with a shape memory. In some configurations, only the mid-section comprises the material with the shape memory, and the first and second sections 1, 5 of the guidewire 100 comprise a material that is different to the mid-section 3. In some configurations only the mid-section 3 is resiliently deformable. In some configurations 20 the guidewire 100 is manufactured entirely from a material with a shape memory. In some configurations the entire guidewire 100 is wrapped in a biocompatible sheath such that no part of the shape memory material is exposed. In some configurations the guidewire 100 may comprise a core of a material with a shape memory, a layer of another material, for example a metal, and an outer layer of a biocompatible material, for 25 example PTFE.

In some configurations, the mid-section 3 of the guidewire 100 is plastically deformable. That is, once the guidewire 100 has been pulled, the mid-section 3 will remain in the straightened shape or the second configuration. In some configurations, at least one of 30 the first section 1 and the second section 5 are plastically deformable.

In some configurations the guidewire 100 is configured to be straightened from an original shape or a first configuration to a straightened shape or second configuration by

the application of any force, for example tension, compression or torsion.

In some configurations, the second section 5 is configured to have a shape or morphology that makes the guidewire 100 more compact and less likely to become de-sterilised (for example, by accidentally letting the second section 5 come into contact with the floor). In some configurations, only a portion of the second section 5, for example the proximal end of the second section 5, has a shape or morphology that makes the guidewire 100 more compact and less likely to become de-sterilised. For example, the second section 5 may be configured to have a curve, bend, spiral, helix or coiled shape, as shown in Fig. 9. In some configurations, the second section 5 may be configured to have a “treble-clef” shape, or a “pig-tail” shape. In configurations where both the mid-section 3 and the second section 5 have a curve, bend, helix, spiral or coil, the curve, bend, helix, spiral or coil of the second section 5 may be configured to have a radius of curvature greater than that of the mid-section 3. For example, the mid-section 3 may have a tight spiral whereas the second section 5 may have a wider, looser spiral. In this way, the catheter 9 can still be fed onto the guidewire 100 over the second section 5, but movement further along the guidewire 100 will be inhibited by the tighter curves or spirals of the mid-section 3.

In some configurations at least one of the second section 5 and the mid-section 3 are thinner than the first section 1. When the guidewire 100 is inserted into the patient, and is straightened by the operator, there will be a degree of resistance to the pulling action imposed on the guidewire 100 by the portion of the guidewire 100 that is inside the patient. By making the first section 1 thicker than at least one of the mid-section 3 and the second section 5, this provides a greater degree of resistance to the pulling or straightening action acting on the guidewire 100 and hence makes it easier for an operator to straighten the guidewire 100. Furthermore, when the guidewire 100 is straightened by the operator, all sections of the guidewire 100 may be deformed by the applications of the pulling force imposed by the operator. By making at least one of the second section 5 and the mid-section 3 thinner than the first section 1, the mid-section 3 and/or the second section 5 are more easily deformable than the first section 1 and hence it is easier for the mid-section 3 to be straightened.

In some configurations the second section 5 is at least 1 cm longer than the catheter 9. In some configurations, the entire guidewire 100 is at least twice as long as the catheter 9 that it is guiding. For example, in some configurations the catheter 9 is a central line that is 15-20 cm long, and so the second section 5 may be at least 21 cm long. In some configurations, the second section 5 may be at least twice as long as the catheter 9 that it is guiding.

In some configurations the operator may only insert the guidewire 100 partially into the patient such that only a portion of the first section 1 of the guidewire 100 is in the patient. In some configurations, once the needle 11 is removed, the guidewire 100 may be further inserted into the patient until the mid-section 3 abuts the patient. For example, the guidewire 100 may be inserted into the patient until the mid-section 3 abuts the patient's skin. To freely insert the guidewire 100 further into the patient, the operator may straighten the mid-section of the guidewire 100 such that it is in the straightened shape or second configuration.

The needle 11 may be a cannula or a funnel or any other similar apparatus to aid insertion of the guidewire 100 into the patient. In some configurations the first section 1 is at least as long as the needle 11 through which the guidewire 100 is inserted. For example, the needle 11 may be 6 cm long, and so the first section 1 may be at least 9 cm long. In some configurations, the first section 1 is at least twice as long as the needle 11 through which the guidewire 100 is inserted. The first section 1 may be configured such that at least a portion of it, for example a 3 to 4 cm portion, extends into the desired vein, artery or body cavity of the patient when the guidewire 100 is inserted into the patient up unto the mid-section 3. In other words, when the guidewire 100 is inserted into the patient such that the mid-section 3 abuts the patient's skin and prevents further insertion of the guidewire 100 into the patient, the guidewire 100 is configured such that a portion of it, for example 3 to 4 cm, extends into the desired vein, artery or body cavity of the patient. The configured length of the first portion 1 of the guidewire 100, and/or the total length of the guidewire 100, may be adapted for the intended use of the guidewire 100. For example, if the guidewire 100 is intended to guide placement of a coronary stent through a femoral access point, the guidewire 100 will be longer than a guidewire intended to guide placement of a chest drain.

In some configurations the guidewire 100 must be straightened to allow the needle 11 to pass over the mid-section 3 of the guidewire 100. In some configurations the operator uses a dilator to expand the opening created by the needle 11. For example, the dilator 5 may be passed over the guidewire 100 after the first portion 1 has been inserted into the patient. The dilator may be used with or without the needle 11 in place. The dilator may be fed over the mid-section 3 in the same way as the needle 11 may be passed over the mid-section 3. In some configurations the guidewire 100 must be straightened to allow the dilator to pass over the mid-section 3 of the guidewire 100.

10

In some configurations the first section 1 and the second section 5 are the same length. In some configurations the first section 1, the mid-section 3 and the second section 5 have the same length. In some configurations, the second section 5 has a length greater than the first section 1 and/or the mid-section 3. In some configurations the first section 15 1 has a length shorter than the mid-section 3 and/or the second section 5. Although the mid-section 3 is called a mid-section, it will be understood that this does not necessarily mean that the mid-section 3 must be centrally located on, or in the middle of, the guidewire 100. In some configurations the mid-section 3 will be closer to the proximal end or the distal end of the guidewire 100.

20

In some configurations the guidewire 100 is coloured to aid operation of the guidewire by the operator. For example, each section of the guidewire 100 may be a different colour. In some configurations, there may be a marking indicating the transition between each section of the guidewire 100. For example, the marking may be at least one of a 25 coloured band, a ridge of a material coating the guidewire 100 and a thickening or change in diameter of the guidewire 100.

The catheter 9 may be any tube that is suitable for the transfer of fluids and/or gasses into and/or out of a patient. For example, the catheter 9 may be a venous catheter, an 30 arterial catheter, a urinary catheter or a chest drain.

The guidewire 100 may be manufactured to have a shape memory by heating a portion of the wire, for example the mid-section 3, on a jig or mandrel. In this way, the mid-

- 17 -

section 3 of the guidewire 100 may have a memory for a shape different to that of the remaining portions of the guidewire 100. The manufacturing process may further include coating the guidewire 100 in a biocompatible material.

5 In the context of the present disclosure other examples and variations of the apparatus and methods described herein will be apparent to a person of skill in the art.

CLAIMS:

1. A medical guidewire for assisting placement of a tube into a patient, comprising:
a first section;
5 a mid-section configured to be straightened from an original shape to a straightened shape; and
a second section configured to protrude out of the tube when the tube reaches the mid-section during the placement;
wherein
10 in the original shape the mid-section comprises at least one of a curve bend or a kink configured to indicate to the operator to stop feeding the first section into the patient and to discourage guidewire retention in the tube by allowing the second section to protrude out of the tube when the tube reaches the mid-section; and
in the straightened shape, the mid-section is configured to allow the tube to pass
15 along the mid-section and into the patient.

2. The guidewire of claim 1 wherein the first section is located at a distal end of the guidewire and the second section is located at a proximal end of the guidewire and the guidewire is further configured to:
20 straighten when each end is held and the wire is pulled, and reform into its original shape when released.

3. The guidewire of any one of claims 1 or 2 wherein at least one of the first section and the second section is arranged to form a substantially straight configuration.
25

4. The guidewire of any one of claims 1 to 3 wherein the mid-section is arranged to operate in two configurations, and:
in the first configuration, corresponding to the original shape, the mid-section is configured to form a shape for inhibiting insertion of the guidewire into
30 the patient and inhibiting insertion of the tube over the mid-section of the guidewire into the patient; and
in the second configuration, corresponding to the straightened shape, the mid-section is configured to form a shape for allowing insertion of the tube over

the guidewire and into the patient.

5. The guidewire of claim 4 wherein in the first configuration, the mid-section comprises at least one of: a spiral, a helix, a coil, a curve, a bend that doubles back on
5 itself with an acute angle, or a kink.
6. The guidewire of any one of the previous claims wherein in the original shape the mid-section comprises a v-shaped angle of between 0 and 150 degrees.
- 10 7. The guidewire of claim 5 wherein the helix forms at least one complete revolution.
8. The guidewire of any one of the previous claims wherein the mid-section is resiliently deformable such that upon the application of a pulling force it can be straightened from its original shape to the straightened shape, but will return to its
15 original shape when released.
9. The guidewire of any one of claims 1 to 8 wherein the tube is configured to supply a fluid or remove a fluid from the patient.
- 20 10. The guidewire of claim 9 wherein the tube comprises at least one of a venous catheter, an arterial catheter and a chest drain.
11. The guidewire of any one of the previous claims wherein the first section is at least twice as long as an introduction funnel through which the first section is configured
25 to be passed during placement of the tube into the patient.
12. The guidewire of any one of the previous claims wherein the guidewire comprises an atraumatic tip.
- 30 13. The guidewire of claim 12 wherein the atraumatic tip is located at a distal end of the guidewire; and
the second section is arranged to form a curve, bend or kink configuration at the proximal end of the guidewire.

14. The guidewire of any one of claims 1 to 13 wherein the second section is arranged to comprise at least one of a spiral, a helix, a coil, a curve, a bend that doubles back on itself with an acute angle, or a kink.

5

15. The guidewire of any one of the previous claims wherein at least one of the first section, the mid-section and the second section of the guidewire are resiliently deformable.

10 16. The guidewire of any one of the previous claims wherein the guidewire comprises a core of material having a shape memory.

17. The guidewire of claim 16, further comprising a sheath of biocompatible material.

15 18. The guidewire of claim 16 or 17 wherein the core comprises Nitinol.

19. The guidewire of any one of the previous claims comprising at least one of a change in colour and a change in diameter between at least two sections of the guidewire.

20

20. A cassette for a medical guidewire, comprising:

a storage tube;

a cone portion;

a feeding member adapted to feed the guidewire from the storage tube into the

25 cone portion; and

a guidewire according to any one of the previous claims accommodated in the tube.

21. The cassette of claim 20 wherein the storage tube is arranged to operate in a
30 spiral configuration when accommodating the guidewire.

22. The cassette of any one of claims 20 or 21 wherein the guidewire is configured to be stored in the cassette in the straightened or second configuration but will reform to its

original shape or first configuration when released from the cassette.

23. A medical kit comprising:
a guidewire according to any one of claims 1 to 19;
5 a tube for supplying a fluid or removing a fluid from a patient, and
a cover sealing the guidewire and the tube.
24. The medical kit of claim 23 further comprising a funnel for inserting a portion of
the guidewire into the patient.
10
25. The medical kit of any one of claims 23 or 24, further comprising a cassette of any
one of claims 20 to 22.
26. The medical kit of any one of claims 23 to 25, wherein the cover is configured to
15 seal the guidewire and/or the tube so that they remain sterile.
27. A method of manufacturing a medical guidewire, comprising:
obtaining a length of wire having a shape memory;
heating the wire on a jig or mandrel to give a portion of the wire a memory for a
20 shape different to that of the remaining portions of the wire;
coating the wire in a biocompatible material.
28. A medical guidewire substantially as described herein with reference to the
drawings.
25
29. A cassette substantially as described herein with reference to the drawings.
30. A medical kit substantially as described herein with reference to the drawings.
- 30 31. A method of placing a tube into a patient, comprising:
providing a medical guidewire comprising a first section, a mid-section configured
to be operated from an original shape to a straightened shape, wherein in the original
shape the mid-section comprises at least one of a curve bend or a kink, and a second

- 22 -

section;

providing a tube for insertion into the patient;

inserting the first section of the guidewire into the patient;

applying a force to the guidewire to cause it to be straightened from the original

5 shape to the straightened shape; and

feeding the tube along the mid-section and into the patient.

32. The method of claim 31 wherein applying a force to the medical guidewire comprises holding two portions of the guidewire either side of the mid-section and pulling
10 on the guidewire.

33. The method of claim 31 wherein inserting a portion of the medical guidewire comprises inserting the first section of the guidewire into the patient until the mid-section abuts the patient.
15

34. The method of claim 31 wherein the second section is configured to protrude out of the tube when the tube reaches the mid-section during the placement.

35. The method of claim 34 further comprising feeding the tube onto the guidewire
20 before the force is applied to the guidewire.

36. The method of claim 31 wherein providing the guidewire comprises providing the guidewire in a cassette wherein the guidewire is configured to be stored in the cassette in the straightened shape but will reform to its original shape when released from the
25 cassette.

37. The method of claim 36 wherein the cassette comprises:
a storage tube for storing the guidewire;
a cone portion configured to be coupled to a funnel for inserting the guidewire into
30 the patient; and
a feeding member adapted to feed the guidewire from the storage tube into the cone portion by an operator running their thumb along the feeding member and an exposed portion of the guidewire.

38. The method of claim 31 wherein providing the guidewire and providing the tube comprises providing the guidewire and the tube in a medical kit with a cover sealing the guidewire and the tube.

5

39. The method of claim 38 further comprising providing the guidewire in a cassette, wherein the guidewire is configured to be stored in the cassette in the straightened shape but will reform to its original shape when released from the cassette.

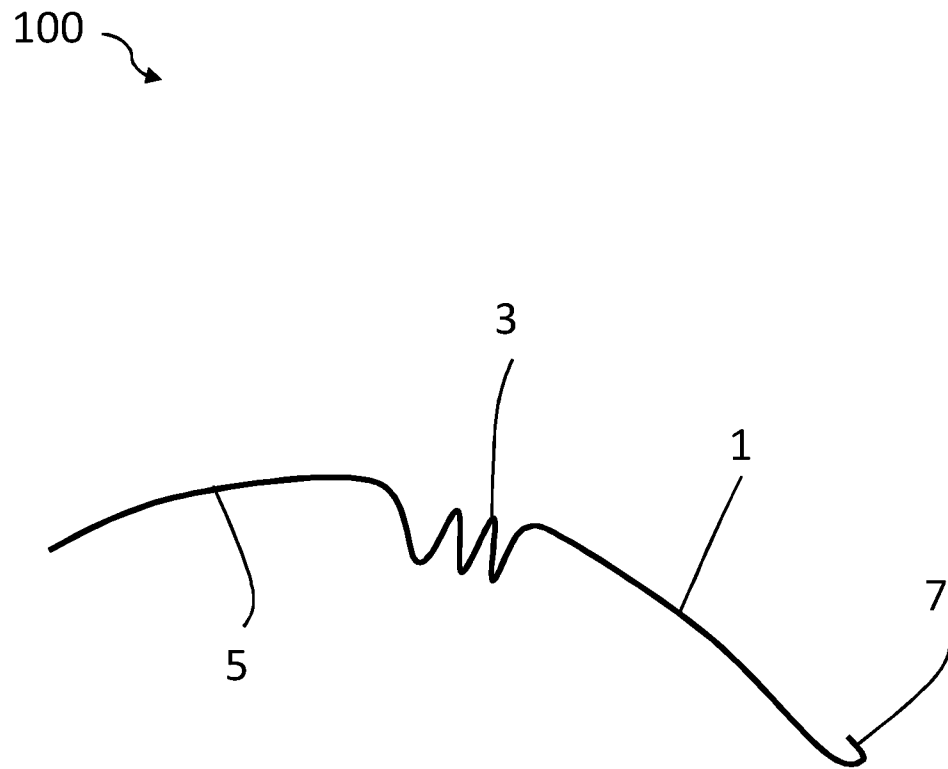

Fig. 1

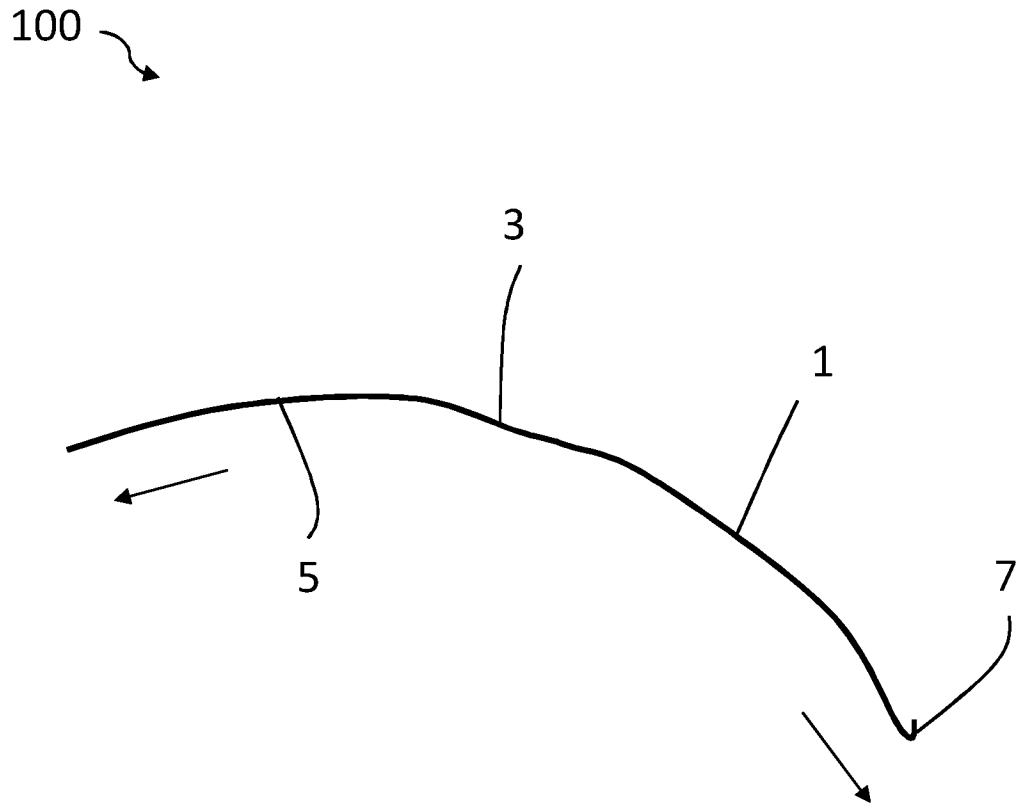

Fig. 2

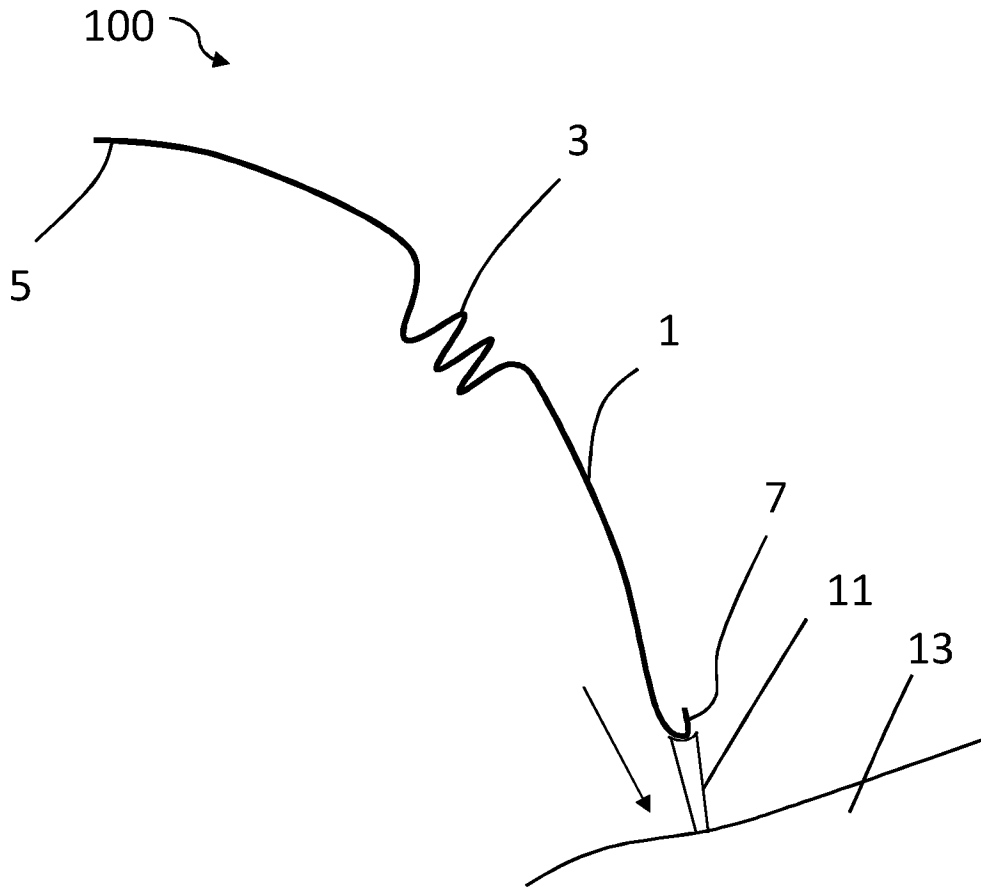

Fig. 3

100 ↘

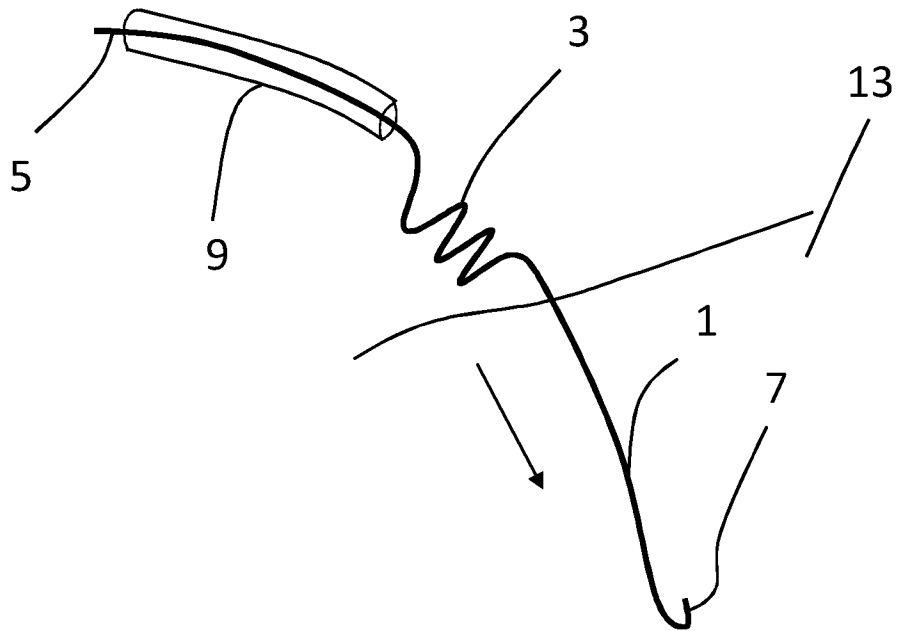

Fig. 4

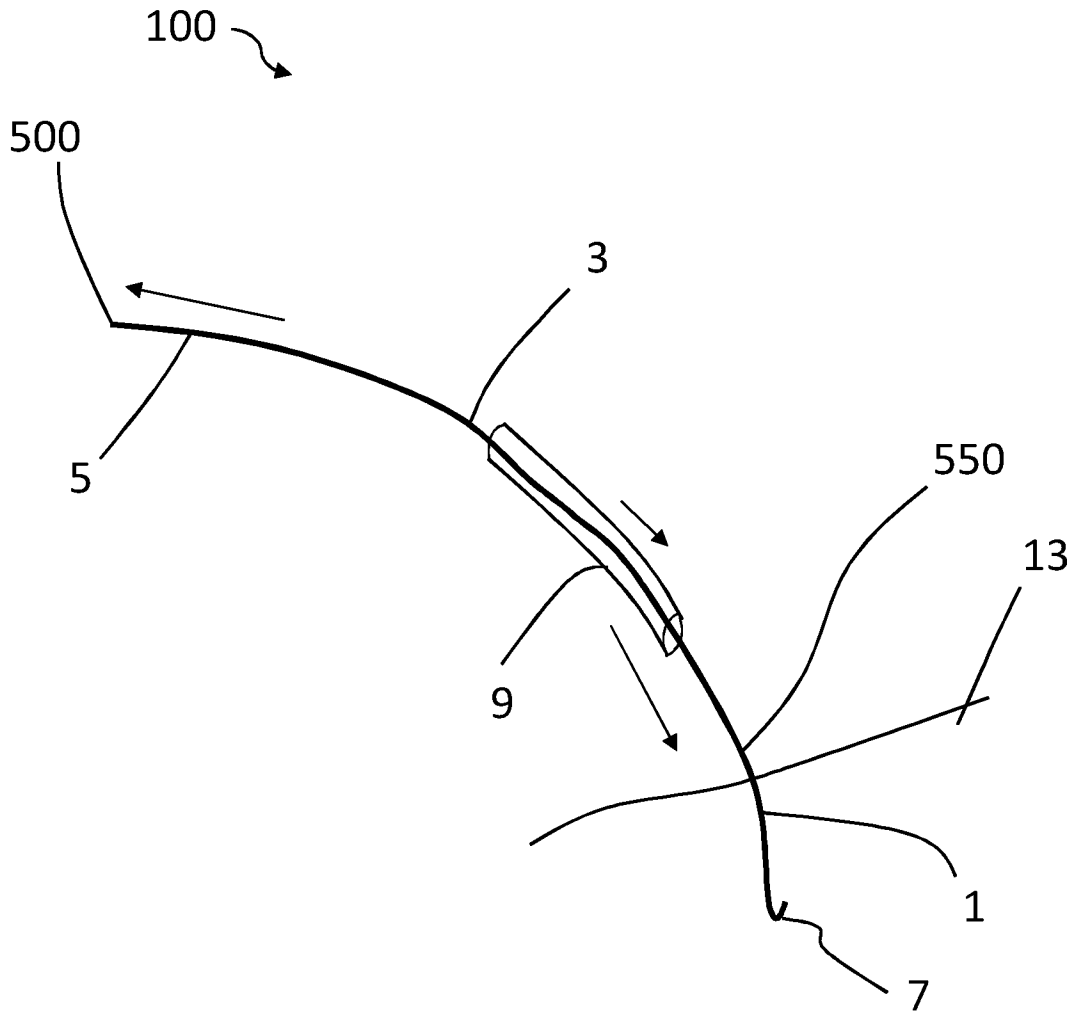

Fig. 5

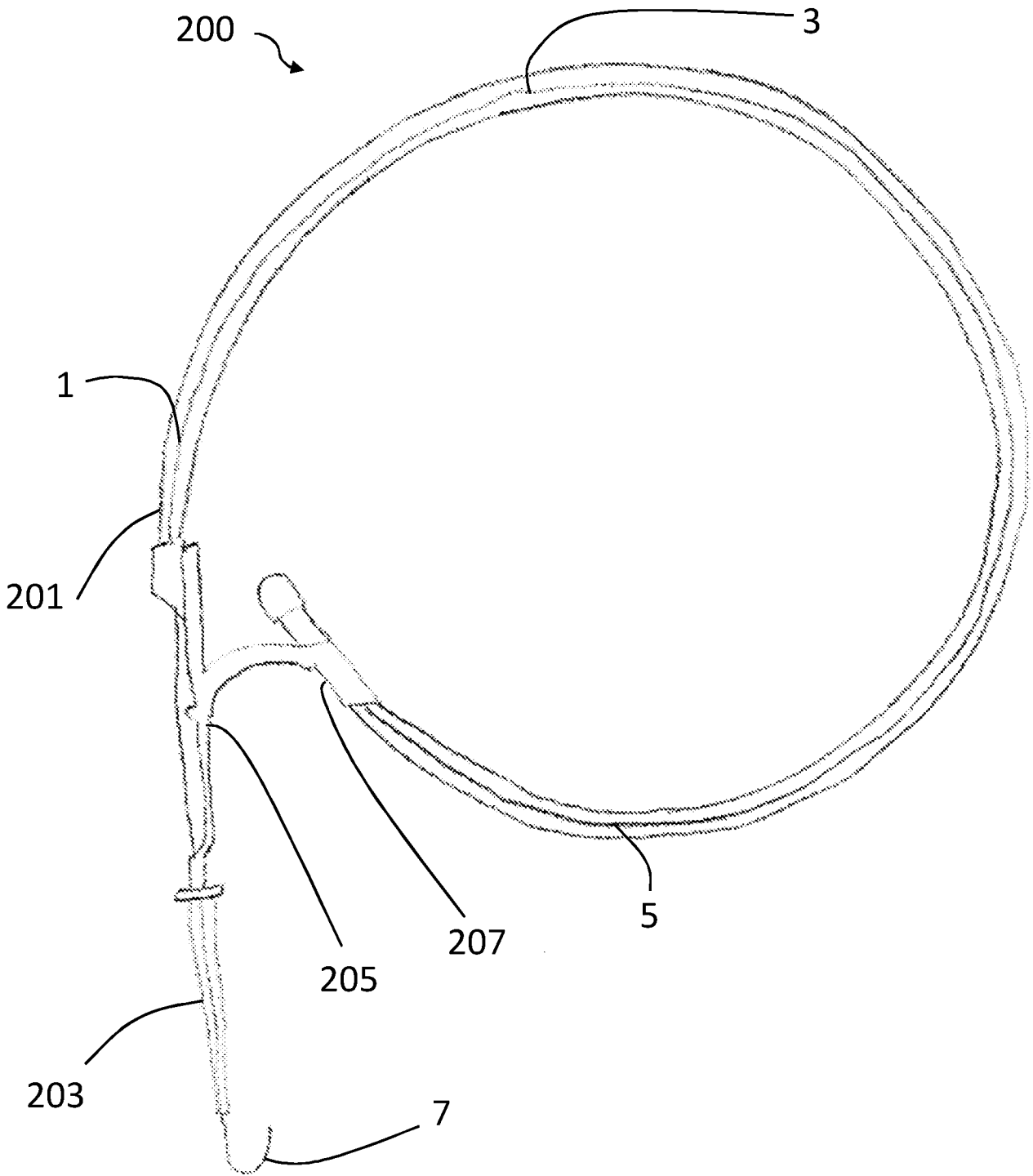

Fig. 6

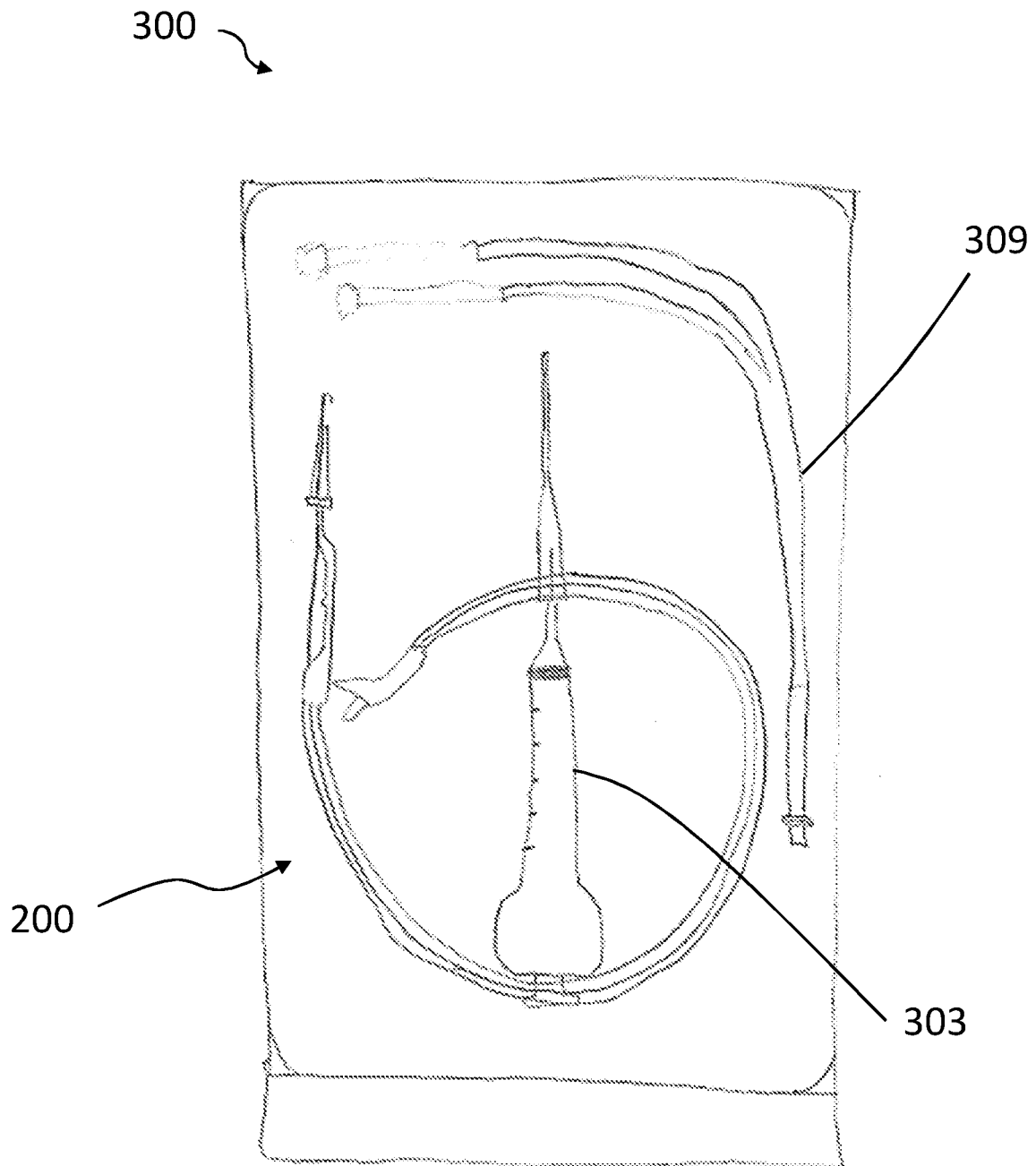

Fig. 7

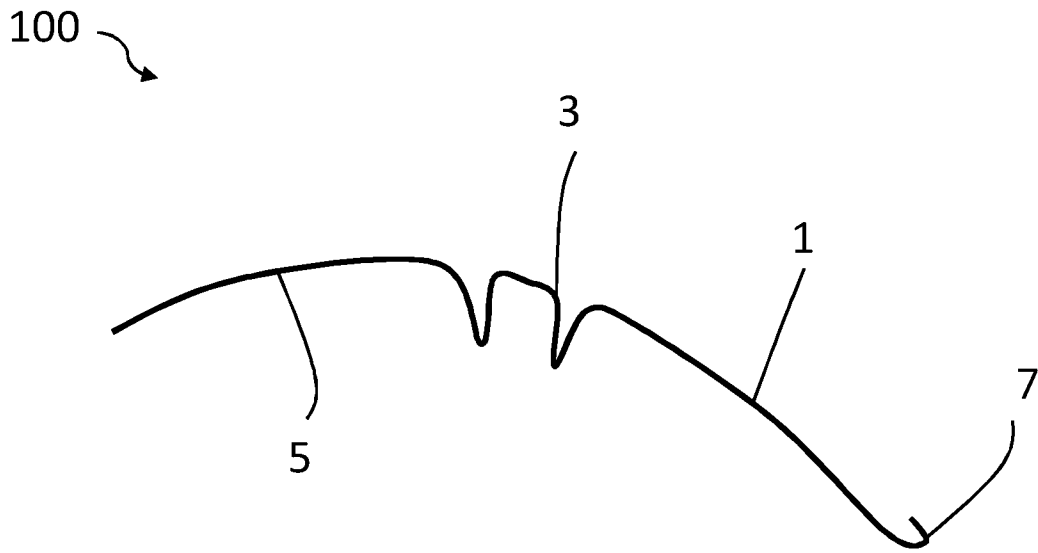

Fig. 8A

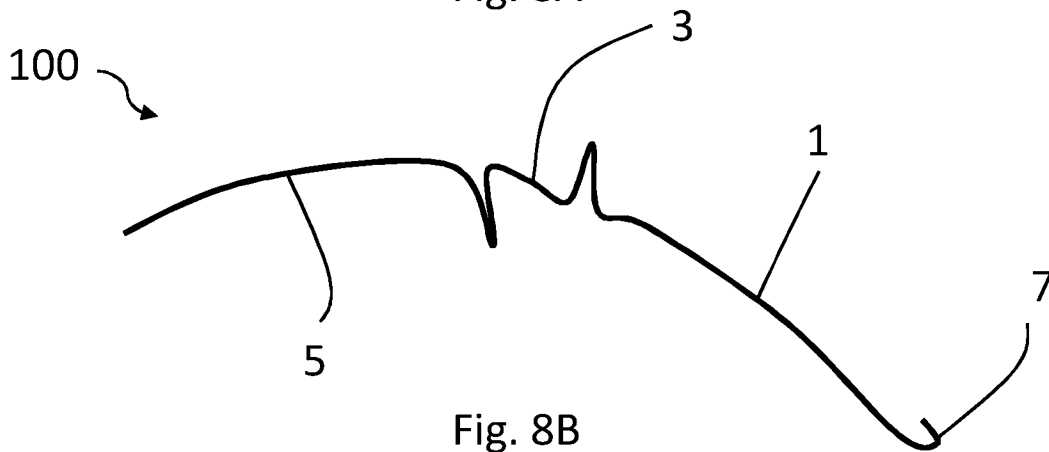

Fig. 8B

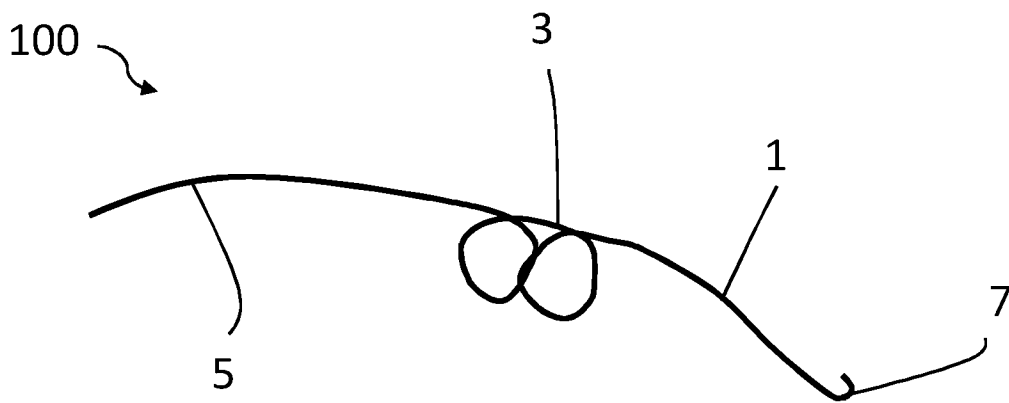

Fig. 8C

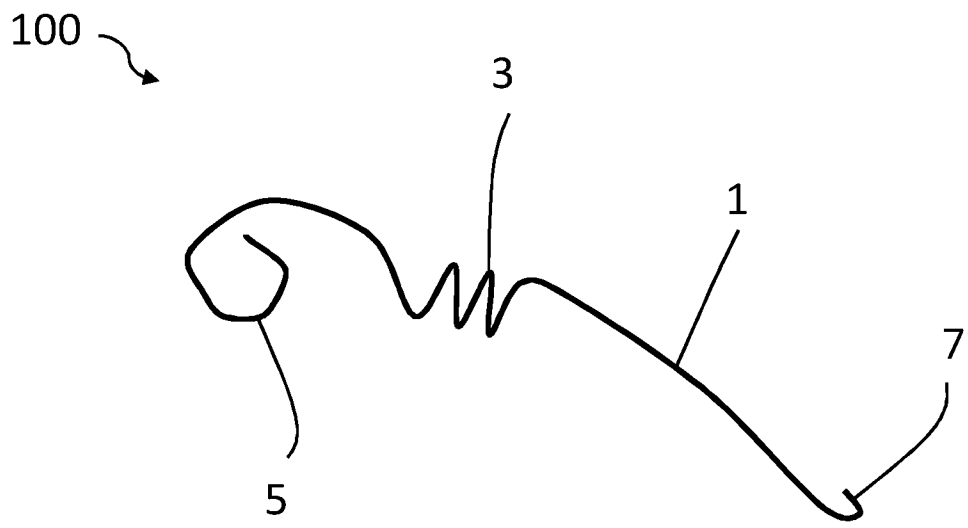

Fig. 9

INTERNATIONAL SEARCH REPORT

International application No
PCT/GB2014/052338

A. CLASSIFICATION OF SUBJECT MATTER
 INV. A61M25/09
 ADD.
 According to International Patent Classification (IPC) or to both national classification and IPC

B. FIELDS SEARCHED
 Minimum documentation searched (classification system followed by classification symbols)
 A61M

Documentation searched other than minimum documentation to the extent that such documents are included in the fields searched

Electronic data base consulted during the international search (name of data base and, where practicable, search terms used)
 EPO-Internal

C. DOCUMENTS CONSIDERED TO BE RELEVANT

Category*	Citation of document, with indication, where appropriate, of the relevant passages	Relevant to claim No.
X	US 2009/018526 A1 (POWER JOHN MELMOUTH [AU] ET AL) 15 January 2009 (2009-01-15)	1-6,8-19
Y	paragraphs [0073] - [0076]; figures 1a-1c,8a-8c	20-26
X	WO 2012/135656 A2 (UNIV CORNELL [US]; MIN ROBERT J [US]; DORFMAN GARY S [US]) 4 October 2012 (2012-10-04)	1-6,8,10-19
A	pages 3,13,14; figures 1,4a,4b pages 17,18	20-26
X	WO 01/26725 A1 (PROLIFIX MEDICAL INC [US]) 19 April 2001 (2001-04-19)	1-19,27
A	page 6; figures 2a,3a-3c,5a page 14, lines 25-35 pages 11,12	20-26
	----- -/--	

Further documents are listed in the continuation of Box C. See patent family annex.

* Special categories of cited documents :

"A" document defining the general state of the art which is not considered to be of particular relevance	"T" later document published after the international filing date or priority date and not in conflict with the application but cited to understand the principle or theory underlying the invention
"E" earlier application or patent but published on or after the international filing date	"X" document of particular relevance; the claimed invention cannot be considered novel or cannot be considered to involve an inventive step when the document is taken alone
"L" document which may throw doubts on priority claim(s) or which is cited to establish the publication date of another citation or other special reason (as specified)	"Y" document of particular relevance; the claimed invention cannot be considered to involve an inventive step when the document is combined with one or more other such documents, such combination being obvious to a person skilled in the art
"O" document referring to an oral disclosure, use, exhibition or other means	"&" document member of the same patent family
"P" document published prior to the international filing date but later than the priority date claimed	

Date of the actual completion of the international search 23 September 2014	Date of mailing of the international search report 02/10/2014
--	--

Name and mailing address of the ISA/ European Patent Office, P.B. 5818 Patentlaan 2 NL - 2280 HV Rijswijk Tel. (+31-70) 340-2040, Fax: (+31-70) 340-3016	Authorized officer Bielsa, David
--	---

INTERNATIONAL SEARCH REPORT

International application No
PCT/GB2014/052338

C(Continuation). DOCUMENTS CONSIDERED TO BE RELEVANT

Category*	Citation of document, with indication, where appropriate, of the relevant passages	Relevant to claim No.
X	US 5 143 085 A (WILSON BRUCE C [US]) 1 September 1992 (1992-09-01) column 6, lines 19-27; figure 2b -----	1-6, 8-16,18, 19
Y	US 5 139 032 A (JAHRMARKT SCOTT L [US] ET AL) 18 August 1992 (1992-08-18) column 4, lines 61-68; figure 3 column 5, lines 1-18 -----	20-26

INTERNATIONAL SEARCH REPORT

International application No.
PCT/GB2014/052338

Box No. II Observations where certain claims were found unsearchable (Continuation of item 2 of first sheet)

This international search report has not been established in respect of certain claims under Article 17(2)(a) for the following reasons:

1. Claims Nos.: 31-39
because they relate to subject matter not required to be searched by this Authority, namely:
see FURTHER INFORMATION sheet PCT/ISA/210

2. Claims Nos.: 28-30
because they relate to parts of the international application that do not comply with the prescribed requirements to such an extent that no meaningful international search can be carried out, specifically:
see FURTHER INFORMATION sheet PCT/ISA/210

3. Claims Nos.:
because they are dependent claims and are not drafted in accordance with the second and third sentences of Rule 6.4(a).

Box No. III Observations where unity of invention is lacking (Continuation of item 3 of first sheet)

This International Searching Authority found multiple inventions in this international application, as follows:

1. As all required additional search fees were timely paid by the applicant, this international search report covers all searchable claims.

2. As all searchable claims could be searched without effort justifying an additional fees, this Authority did not invite payment of additional fees.

3. As only some of the required additional search fees were timely paid by the applicant, this international search report covers only those claims for which fees were paid, specifically claims Nos.:

4. No required additional search fees were timely paid by the applicant. Consequently, this international search report is restricted to the invention first mentioned in the claims; it is covered by claims Nos.:

Remark on Protest

- The additional search fees were accompanied by the applicant's protest and, where applicable, the payment of a protest fee.
- The additional search fees were accompanied by the applicant's protest but the applicable protest fee was not paid within the time limit specified in the invitation.
- No protest accompanied the payment of additional search fees.

FURTHER INFORMATION CONTINUED FROM PCT/ISA/ 210

Continuation of Box II.1

Claims Nos.: 31-39

Claims 31-39 relate to a method for treatment of the human or animal body by surgery, because they all explicitly comprise the steps of placing a tube into a patient and inserting the first section of the guidewire into the patient, any of which is an considered a surgical procedure. This Authority is not required to search the present application with respect to the aforementioned claims (Article 17(2)(b) PCT and Rule 39.1(iv) PCT). Consequently, no International Search Report and no Written Opinion (Rule 67.1 PTC in combination with Rule 43bis.1(b) PCT) have been established with respect to them.

Continuation of Box II.2

Claims Nos.: 28-30

Claims 28-30 rely solely on references to the description or drawings. Such a claim is not acceptable according to Tule 6.2(a) PCT.

The applicant's attention is drawn to the fact that claims relating to inventions in respect of which no international search report has been established need not be the subject of an international preliminary examination (Rule 66.1(e) PCT). The applicant is advised that the EPO policy when acting as an International Preliminary Examining Authority is normally not to carry out a preliminary examination on matter which has not been searched. This is the case irrespective of whether or not the claims are amended following receipt of the search report or during any Chapter II procedure. If the application proceeds into the regional phase before the EPO, the applicant is reminded that a search may be carried out during examination before the EPO (see EPO Guidelines C-IV, 7.2), should the problems which led to the Article 17(2) declaration be overcome.

INTERNATIONAL SEARCH REPORT

Information on patent family members

International application No PCT/GB2014/052338

Patent document cited in search report	Publication date	Patent family member(s)	Publication date	
US 2009018526	A1	15-01-2009	AU 2006284540 A1	01-03-2007
			EP 1917054 A1	07-05-2008
			US 2009018526 A1	15-01-2009
			US 2013253629 A1	26-09-2013
			WO 2007022592 A1	01-03-2007

WO 2012135656	A2	04-10-2012	CN 103533983 A	22-01-2014
			EP 2691141 A2	05-02-2014
			US 2014088560 A1	27-03-2014
			WO 2012135656 A2	04-10-2012

WO 0126725	A1	19-04-2001	AU 1432801 A	23-04-2001
			US 6371928 B1	16-04-2002
			US 2002103446 A1	01-08-2002
			WO 0126725 A1	19-04-2001

US 5143085	A	01-09-1992	NONE	

US 5139032	A	18-08-1992	NONE	
