

S. F. Smith.

Stand Paper Mach.

N^o 110,165.

Patented Dec. 13, 1870.

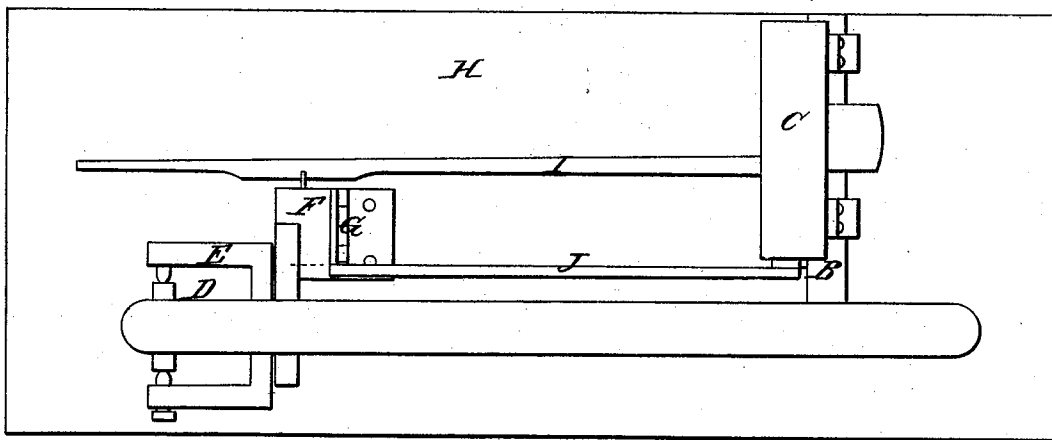
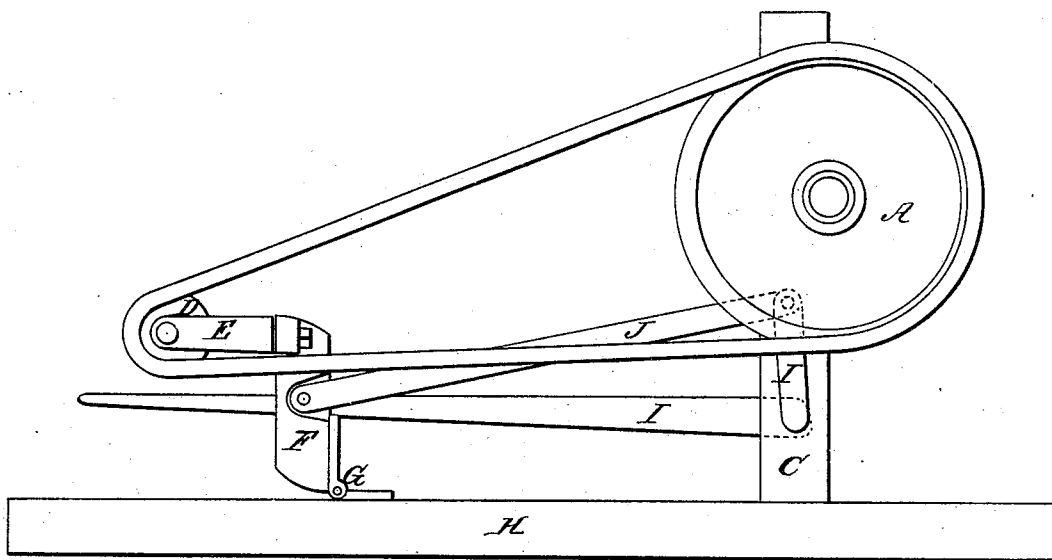

Witnesses;
Spurr & Weeks
C. F. Mayhew.

Inventor;
Samuel F. Smith

United States Patent Office.

SAMUEL F. SMITH, OF INDIANAPOLIS, INDIANA, ASSIGNOR TO OSGOOD, SMITH & CO., OF SAME PLACE.

Letters Patent No. 110,165, dated December 13, 1870.

IMPROVEMENT IN SAND-PAPERING MACHINES

The Schedule referred to in these Letters Patent and making part of the same.

To all whom it may concern:

Be it known that I, SAMUEL F. SMITH, of Indianapolis, in the county of Marion and State of Indiana, have invented new and useful Improvements in Sand-Belts, or machines for sand-finishing plow-handles, lasts, &c.; and I do hereby declare that the following is a full, clear, and exact description thereof, reference being had to the accompanying drawings and to the letters of reference marked thereon making part of this specification.

This invention relates to improvements in machines for sand-polishing plow-handles, shoe-lasts, &c., and consists in the arrangement of devices for adjusting one of the pulleys whereon the sand-belt is placed, as hereinafter described.

Figure 1 is a side elevation of the device.

Figure 2 is a top or plan view of the same.

Similar letters of reference indicate corresponding parts of the several figures.

The driving or principal pulley, A, that operates the sand belt is attached to a shaft, B, that is hung in an upright frame, C, or in any other convenient manner.

The secondary pulley D, that carries the other end of the sand-belt, is hung by pivots in an adjustable head, E, that is attached by a pivot-bolt to the upper end of the adjustable standard F, the lower end of which is attached by a hinge-joint, G, to the floor H, as shown.

The belt is strained or tightened over the pulleys A and D by means of the bent lever I and connecting bar J, by which the standard F, carrying the head E, may be readily and conveniently adjusted to tighten the belt or thrown forward to remove it, as may be required. This manner of hanging the head E to the adjustable standard F is also convenient for taking off and putting on the belt, which frequently has to be done to renew the sand, and it is by this means, also, that the middle portion of the belt may be stretched and made to conform to the rounded face of the pulleys A and D.

In resanding the belt it is liable to shrink unequally, in which case it would not run true, and would be liable to run off the pulley. It is also liable to run off the pulleys in the operation of smoothing and finishing, especially when, from the nature of the article operated upon, or the inexperience of the workman, one edge of the belt is used. In order to compensate for the unequal shrinkage, and to counteract any tendency of the belt to run off the pulleys by pressure upon one edge, the head E, in which the secondary pulley D is hung, is made adjustable so that the axis of the pulley may be readily adjusted at right angles to the general line of the belt.

The difficulties heretofore experienced in smoothing and finishing articles having irregular or rounded surfaces and short curves have been because the surfaces of the sand-wheels in use for that purpose were not of a sufficiently flexible nature to adapt themselves to such surfaces and forms; and the narrow flat belts, while possessing the requisite flexibility, were objectionable on account of the liability of the edges of the belt to cut into and make notches in the surface.

By the use of a wide belt running over round-faced pulleys, so as to give it semicircular form, these objections are wholly obviated. In addition thereto a largely-increased working surface is obtained, by which the operation of smoothing and finishing such articles as plow-handles, lasts, &c., are more expeditiously and effectively performed.

Having thus fully described my invention,

What I claim as new, and desire to secure by Letters Patent, is—

The lever I and connecting-bar J, in combination with the hinged standard F and swiveled bearing E and pulley D, as and for the purpose specified.

SAML. F. SMITH.

Witnesses:

WM. H. WEEKS,
O. F. MAYHEW.