

(12) INTERNATIONAL APPLICATION PUBLISHED UNDER THE PATENT COOPERATION TREATY (PCT)

(19) World Intellectual Property Organization
International Bureau



(43) International Publication Date
29 December 2011 (29.12.2011)

(10) International Publication Number
WO 2011/163543 A1

- (51) **International Patent Classification:**
G11B 7/252 (2006.01) *G11B 7/003* (2006.01)
- (21) **International Application Number:**
PCT/US2011/041737
- (22) **International Filing Date:**
24 June 2011 (24.06.2011)
- (25) **Filing Language:** English
- (26) **Publication Language:** English
- (30) **Priority Data:**
12/822,592 24 June 2010 (24.06.2010) US
- (71) **Applicant (for all designated States except US):** **ORACLE INTERNATIONAL CORPORATION** [US/US];
500 Oracle Parkway, Redwood City, California 94065 (US).
- (72) **Inventor; and**
- (75) **Inventor/Applicant (for US only):** **KIM, Eui Kyoan** [KR/US]; 111 Locust Street TH82, Woburn, Massachusetts 01801 (US).
- (74) **Agents:** **PROSCIA, James W.** et al.; Brooks Kushman P.C., 1000 Town Center, Twenty-Second Floor, Southfield, Michigan 48075 (US).
- (81) **Designated States (unless otherwise indicated, for every kind of national protection available):** AE, AG, AL, AM, AO, AT, AU, AZ, BA, BB, BG, BH, BR, BW, BY, BZ,

CA, CH, CL, CN, CO, CR, CU, CZ, DE, DK, DM, DO, DZ, EC, EE, EG, ES, FI, GB, GD, GE, GH, GM, GT, HN, HR, HU, ID, IL, IN, IS, JP, KE, KG, KM, KN, KP, KR, KZ, LA, LC, LK, LR, LS, LT, LU, LY, MA, MD, ME, MG, MK, MN, MW, MX, MY, MZ, NA, NG, NI, NO, NZ, OM, PE, PG, PH, PL, PT, RO, RS, RU, SC, SD, SE, SG, SK, SL, SM, ST, SV, SY, TH, TJ, TM, TN, TR, TT, TZ, UA, UG, US, UZ, VC, VN, ZA, ZM, ZW.

- (84) **Designated States (unless otherwise indicated, for every kind of regional protection available):** ARIPO (BW, GH, GM, KE, LR, LS, MW, MZ, NA, SD, SL, SZ, TZ, UG, ZM, ZW), Eurasian (AM, AZ, BY, KG, KZ, MD, RU, TJ, TM), European (AL, AT, BE, BG, CH, CY, CZ, DE, DK, EE, ES, FI, FR, GB, GR, HR, HU, IE, IS, IT, LT, LU, LV, MC, MK, MT, NL, NO, PL, PT, RO, RS, SE, SI, SK, SM, TR), OAPI (BF, BJ, CF, CG, CI, CM, GA, GN, GQ, GW, ML, MR, NE, SN, TD, TG).

Declarations under Rule 4.17:

- as to applicant's entitlement to apply for and be granted a patent (Rule 4.17(ii))
- as to the applicant's entitlement to claim the priority of the earlier application (Rule 4.17(iii))
- of inventorship (Rule 4.17(iv))

Published:

- with international search report (Art. 21(3))



WO 2011/163543 A1

(54) **Title:** LOW VISCOSITY MONOMER FOR PATTERNING OPTICAL TAPE

(57) **Abstract:** A method for forming an optical tape for data storage from a substrate film includes a step of patterning a curable liquid composition onto a side of the substrate film. Characteristically, the curable liquid composition includes a free radical photoinitiator and a polymerizable component that includes at least one acrylate. The curable liquid composition is illuminated with actinic radiation to form a patterned imprint layer disposed over the substrate film. A multilayer data recording assembly is placed over the imprint layer. An optical tape made by the method is also provided.

LOW VISCOSITY MONOMER FOR PATTERNING OPTICAL TAPE

BACKGROUND

1. Field

[0001] The present invention relates to optical tape storage technology and in particular to methods for making optical tape.

2. Description of the Related Art

[0002] The ever expanding amount of digital data provides an impetus for the continuing development of high capacity storage solutions. Technologies that are suitable for these applications include optical tape, magnetic tape, and optical disks. Of these possibilities, optical tape technology is believed to provide the greater storage capacity.

[0003] The typical optical tape medium includes a base film such as polyethylene naphthalate (PEN) over-coated with multiple layers for recording digital data. A polymeric imprint layer is usually disposed over the base film. In one type of optical tape, the imprint layer is over-coated with a reflective metallic layer that is, in turn, over-coated with a sequence of dielectric layer, phase change layer, and dielectric layer. The actual data recording and reading occurs in the phase change layer. In a typical application, a pulsed laser beam is projected from an optical head assembly onto the optical tape thereby causing a phase change in the phase change layer that results in data being encoded therein. Data encoded onto the optical tape is also read with a laser with the reflective layer reflecting light to a detector. Moreover, optical tape usually includes optical servo marks embossed into the imprint layer along the length of the tape for operating with a servo control system for controlling the optical head, Although

the current optical tape technology works reasonably well, there are a number of problems related to the polymeric imprint layer.

[0004] The imprint layers tend to cause a number of detrimental effects due to dimensional changes that occur therein. For example, such dimensional changes may cause thickness variations in the metal and dielectric layers. Although these effects are believed to be due to poor mechanical and thermal properties of the imprint polymer, it is also thought that the sensitivity of the imprint layer to electron beam damage during the metal layer and dielectric layer depositions also contributes to these changes.

[0005] Accordingly, there is a need for new materials and methods for forming the imprint layer used in optical tape media.

SUMMARY OF THE INVENTION

[0006] The present invention solves one or more problems of the prior art by providing, in at least one embodiment, a method for forming an optical tape for data storage from a substrate film. The method of the present embodiment includes a step of patterning a curable liquid composition onto the substrate film. The curable liquid composition comprises a free radical photoinitiator and a polymerizable component that includes at least one acrylate. The curable liquid composition coated on the substrate film is illuminated with actinic radiation to form a patterned imprint layer disposed over the substrate film. A multilayer data recording assembly is placed over the second imprint layer side to form the optical tape. Advantageously, the imprint layer formed in the present embodiment is less susceptible to electron beam damage and has improved mechanical stability as compared to the imprint layers currently used to fabricate optical tape medium.

[0007] In another embodiment, a method for forming an optical tape for data storage from a substrate film is provided. Characteristically, the substrate film includes

a first substrate side and a second substrate side. The method of the present embodiment includes a step of patterning a curable liquid composition onto the substrate film. The curable liquid composition comprises a free radical photoinitiator and a polymerizable component that includes at least one acrylate. The curable liquid composition coated on the substrate film is illuminated with actinic radiation (e.g., UV radiation) to form a patterned imprint layer disposed over the substrate film. A metal layer is deposited over the patterned imprint layer. A first dielectric layer is then deposited onto the metal layer. A phase change layer is then coated onto the first dielectric layer. Finally, a second dielectric layer is deposited onto the phase change layer.

[0008] In still another embodiment, an imprint layer formed by the methods set forth above is provided. The imprint layer includes the residues of a free radical photoinitiator and of a polymerizable component (e.g., monomer) that includes at least one acrylate. The imprint layer optionally further comprises the residues of a free radical photoinitiator.

BRIEF DESCRIPTION OF THE DRAWINGS

[0009] Exemplary embodiments of the present invention will become more fully understood from the detailed description and the accompanying drawing, wherein:

[0010] Figure 1 is a top view of an optical tape medium incorporating an embodiment of an imprint layer;

[0011] Figure 2 is a cross sectional view of an optical tape medium incorporating an embodiment of an imprint layer; and

[0012] Figure 3 is a schema illustration of a system for forming an optical tape medium.

DETAILED DESCRIPTION OF THE INVENTION

[0013] Reference will now be made in detail to presently preferred compositions, embodiments and methods of the present invention, which constitute the best modes of practicing the invention presently known to the inventors. The Figures are not necessarily to scale. However, it is to be understood that the disclosed embodiments are merely exemplary of the invention that may be embodied in various and alternative forms. Therefore, specific details disclosed herein are not to be interpreted as limiting, but merely as a representative basis for any aspect of the invention and/or as a representative basis for teaching one skilled in the art to variously employ the present invention.

[0014] Except in the examples, or where otherwise expressly indicated, all numerical quantities in this description indicating amounts of material or conditions of reaction and/or use are to be understood as modified by the word "about" in describing the broadest scope of the invention. Practice within the numerical limits stated is generally preferred. Also, unless expressly stated to the contrary: percent, "parts of," and ratio values are by weight; the description of a group or class of materials as suitable or preferred for a given purpose in connection with the invention implies that mixtures of any two or more of the members of the group or class are equally suitable or preferred; description of constituents in chemical terms refers to the constituents at the time of addition to any combination specified in the description, and does not necessarily preclude chemical interactions among the constituents of a mixture once mixed; the first definition of an acronym or other abbreviation applies to all subsequent uses herein of the same abbreviation; and, unless expressly stated to the contrary, measurement of a property is determined by the same technique as previously or later referenced for the same property.

[0015] It is also to be understood that this invention is not limited to the specific embodiments and methods described below, as specific components and/or conditions may, of course, vary. Furthermore, the terminology used herein is used only for the purpose of describing particular embodiments of the present invention and is not intended to be limiting in any way.

[0016] It must also be noted that, as used in the specification and the appended claims, the singular form "a," "an," and "the" comprise plural referents unless the context clearly indicates otherwise. For example, reference to a component in the singular is intended to comprise a plurality of components.

[0017] Throughout this application, where publications are referenced, the disclosures of these publications in their entireties are hereby incorporated by reference into this application to more fully describe the state of the art to which this invention pertains.

[0018] With reference to Figures 1 and 2, schematic illustrations of an optical tape medium for storing digital data are provided. Figure 1 is a top view of the optical tape medium. Figure 2 is a cross sectional view of the optical tape medium. Optical tape 10 includes substrate film 12 having substrate film sides 14, 16. Typically, substrate film 12 is formed from polyethylene naphthalate (PEN). Imprint layer 20 is disposed over substrate film side 16. Imprint layer 20 includes imprint layer side 22 and imprint layer side 24 with imprint layer side 22 being more proximate to substrate film 12. Advantageously, imprint layer 20 is made by the process set forth below. Multilayer data recording assembly 28 is disposed over imprint layer 20. Multilayer data recording assembly 28 typically includes one or more layers involved in the optical recording of data.

[0019] Still referring to Figures 1 and 2, an example of multilayer data recording assembly 28 is provided. Multilayer data recording assembly 28 includes metal layer 30

disposed over imprint layer side 24. Metal layer 30 includes metal layer side 32 and metal layer side 34. Metal layer side 32 is more proximate to imprint layer 20 than metal layer side 34. Multilayer data recording assembly 28 also includes dielectric layer 40 disposed over metal layer side 34. Dielectric layer 40 includes dielectric layer side 42 and dielectric layer side 44 which is more proximate to metal layer 30. Multilayer data recording assembly 28 further includes phase change layer 50 which is disposed over dielectric layer 40. Phase change layer 50 includes phase change layer side 52 and phase change layer side 54 which is more proximate to phase change layer 50. Finally, the present embodiment also includes multilayer data recording assembly 28. Multilayer data recording assembly 28 also includes dielectric layer 60 disposed over metal layer side 54.

[0020] With reference to Figure 3, a schematic diagram illustrating the fabrication of the optical storage medium set forth above is provided. Optical tape-forming system 70 includes spool 72 which supplies substrate film 16 which is of a tape-like configuration. During operation of optical tape-forming system 70, substrate film 12 moves in the directions indicated by d_1 - d_5 and is guided by direction rollers 74-82. Substrate film side 16 of substrate film 12 is coated with a curable liquid composition 86 from dispenser 88. In a refinement, curable liquid composition 86 includes free radical photoinitiator and a polymerizable component that includes at least one acrylate. In the variation depicted in Figure 3, dispenser 88 is used to coat curable liquid composition 86 onto substrate film 12. Coated substrate film 94 includes curable liquid layer 96 disposed on substrate film 12. Coated substrate film 94 proceeds to patterning roller 98. Patterning roller 98 includes protrusions 100 that define the pattern to be imprinted upon coated substrate film 94. Curing energy source 102 directs actinic radiation onto curable liquid layer 96 to induce radical polymerization therein to form imprint layer 20. Typically, curing energy source 102 is an ultraviolet ("UV") light source. Heat source 104 is optionally present in order to provide heat to assist in the curing. After curing, imprint layer 20 has pattern 106 imprinted therein

[0021] Still referring to Figure 3, multilayer data recording assembly 28 is fabricated along direction d_5 . In a variation, metal deposition station 110 is used to deposit metal layer 30 over imprint layer 20. Examples of deposition processes that may be used include sputtering and evaporation. Typically, metal deposition 110 is a sputtering reactor. Substrate film 12 proceeds next to dielectric deposition station 112 to form dielectric layer 40. Phase change layer 50 is coated onto dielectric layer 40 at phase change coating system 114. Typically, phase change layer 50 is a metal alloy, which has significant optical and electrical differences between the amorphous and crystalline states. Dielectric layer 60 is deposited onto phase change layer 50 via dielectric deposition station 116. It should be appreciated that metal layer 30, dielectric layers 40, 60 and phase change layer 50 can be single or multilayer structures. For example, some layers use two or three sub-layers to provide better reflection control and long term stability. Finally, optical tape 10 is rolled onto spool 120. Advantageously, the optical tape formed by the present method is observed to have superior mechanical and thermal properties. In particular, the method allows for the imprint layer to be formed with a thickness less than about 2 microns. In another refinement, the imprint layer has a thickness less than about 1.5 microns. In still another refinement, the imprint layer has a thickness greater than from about 0.1 to about 0.5 microns. In yet another variation, the imprint layer has a thickness greater than about 0.2 microns. In yet another variation, the imprint layer has a thickness between 0.3 and 0.4 microns. In still other variations, the imprint layer has a thickness from about 0.1 to about 0.25 microns.

[0022] In some variations, the optical tape processing is paused after formation of the imprint layer. In this variation, the coated substrate may be rolled onto a spool for later processing. In other variations, the optical tape may be subjected to a slitting process in order to fit in a cartridge.

[0023] As set forth above, various embodiments of the present invention advantageously utilize a curable liquid composition that is radically polymerized.

Advantageously, the curable liquid composition has a viscosity less than about 50 cps at 25° C. In another refinement, the curable liquid composition has a viscosity less than about 30 cps at 25° C. In another refinement, the curable liquid composition has a viscosity less than about 20 cps at 25° C. In another refinement, the curable liquid composition has a viscosity less than about 10 cps at 25° C. Typically, the curable liquid composition has a viscosity greater than about 2 cps at 25° C. In another refinement, the curable liquid composition has a viscosity greater than about 5 cps at 25° C. The curable liquid composition includes one or more acrylates. Examples of suitable acrylates include monoacrylates, diacrylates, higher order functionality acrylates, and combinations thereof. In a refinement, the polymerizable component(s) are present in an amount from about 90 to about 99 weight percent of the total weight of the curable liquid composition. In another refinement, the polymerizable component(s) are present in an amount from about 93 to about 99 weight percent of the total weight of the curable liquid composition. In still another refinement, the polymerizable component(s) are present in an amount from about 95 to about 99 weight percent of the total weight of the curable liquid composition.

[0024] In a variation, the curable liquid composition includes an acrylate having formula I:

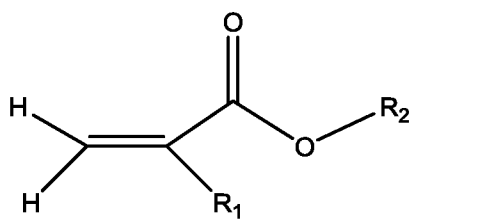

wherein R_1 is hydrogen or substituted or unsubstituted alkyl; and R_2 is a substituted or unsubstituted alkyl having more than 3 carbon atoms, cycloalkyl, cycloalkenyl, or substituted or unsubstituted aryl. Preferably R_1 is hydrogen or methyl; and R_2 is n-butyl, t-butyl, isobornyl, phenyl, benzyl, dicyclopentenyl, dicyclopentenyl oxyethyl, ethylene glycol dicyclopentyl ether, cyclohexyl, and naphthyl. The most preferred ethyleneically

unsaturated monomers are isobornyl acrylate monomers. A particularly useful monomer is provided by the following formula:

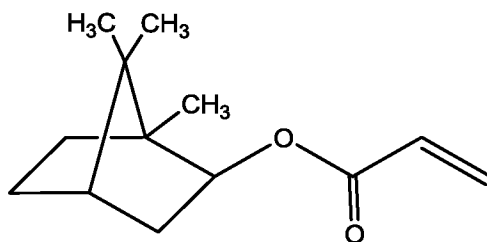

[0025] In a further refinement, the curable liquid composition also includes compounds having formula II:

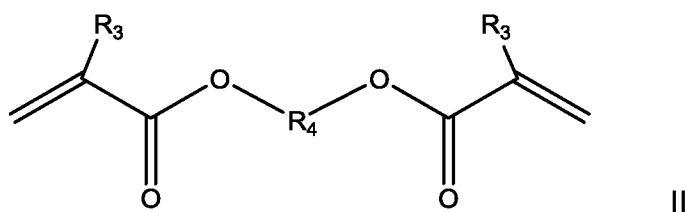

wherein R_3 is hydrogen or substituted or unsubstituted alkyl (e.g., methyl, ethyl, etc) and R_4 is a hydrocarbon moiety. In a refinement, R_4 is an alkylene group. In a further refinement, R_4 is describe by $-(CH_2)_n-$ where n is an integer from 1 to 10. In a particularly useful variation, the compound having formula II has the following formula:

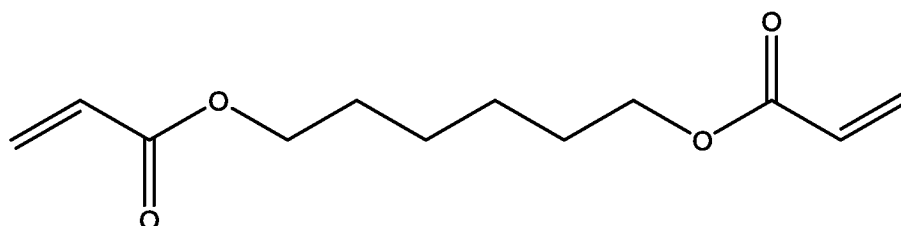

[0026] In a particularly useful variation, the curable liquid composition includes a combination of the compound having formula 1 and the acrylate having formula II. In a

refinement of this variation, the acrylate having formula I is present in an amount from about 55 weight percent to about 75 weight percent of the total weight of the curable liquid composition and the acrylate having formula II is present in an amount from about 25 weight percent to about 45 weight percent of the total weight of the curable liquid composition.

[0027] The curable liquid composition further includes a free radical photoinitiator. Suitable free radical photoinitiators include, but are not limited to, benzophenones, acetophenone derivatives, and combinations thereof. Specific examples include, alpha-hydroxyalkylphenylketones, benzoin (e.g., benzoin alkyl ethers and benzyl ketals), monoacylphosphine oxides, bisacylphosphine oxides, and combinations thereof. A particularly useful photoinitiator is Bis(2,4,6-trimethylbenzoyl)-phenylphosphineoxide. In a refinement, the free radical photoinitiator is present in an amount from about 0.1 to about 10 weight percent of the total weight of the curable liquid composition. In another refinement, the free radical photoinitiator is present in an amount from about 0.5 to about 8 weight percent of the total weight of the curable liquid composition. In still another refinement, the free radical photoinitiator is present in an amount from about 1 to about 5 weight percent of the total weight of the curable liquid composition.

[0028] The various methods of the present invention are used to form a polymeric imprint layer as set forth above. Therefore, the imprint layer is characterized by including residues of one or more of the acrylates set forth above. In particular, the imprint layer includes residues of the compounds describe by Formula I and II. The imprint layer also includes residues of the free radical photoinitiator(s) set forth above.

[0029] A polymeric imprint layer is made by coating a mixture having about 66 weight percent Isobornyl acrylate, 30 weight percent 1,6-Hexanediol diacrylate, and 4 weight percent Bis(2,4,6-trimethylbenzoyl)-phenylphosphineoxide onto a substrate film. The coated substrate film is then cured with UV light while passing over a patterning roller to form the imprint layer.

[0030] While embodiments of the invention have been illustrated and described, it is not intended that these embodiments illustrate and describe all possible forms of the invention. Rather, the words used in the specification are words of description rather than limitation, and it is understood that various changes may be made without departing from the spirit and scope of the invention.

WHAT IS CLAIMED IS:

1. A method for forming an optical tape for data storage from a substrate film, the substrate film having a first substrate side and a second substrate side, the method comprising:
 - a) patterning a curable liquid composition onto the second side of the substrate film, the curable liquid composition comprising a radical photoinitiator and a polymerizable component comprising at least one acrylate;
 - b) illuminating the curable liquid composition to form a patterned imprint layer disposed over the substrate film, the imprint layer having a first imprint layer side and a second imprint layer side, the first imprint layer side being more proximate to the second substrate side than the second imprint layer side; and
 - c) placing a multilayer data recording assembly over the second imprint layer side.

2. The method of claim 1 wherein the curable liquid composition includes an acrylate having formula I:

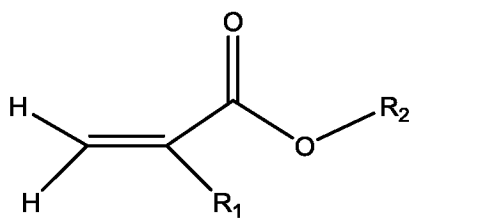

wherein R_1 is hydrogen or substituted or unsubstituted alkyl; and R_2 is a substituted or unsubstituted alkyl having more than 3 carbon atoms, cycloalkyl, cycloalkenyl, or substituted or unsubstituted aryl.

3. The method of claim 2 wherein R_1 is hydrogen or methyl.

4. The method of claim 2 wherein R_2 is n-butyl, t-butyl, isobornyl, phenyl, benzyl, dicyclopentenyl, dicyclopentenyl oxyethyl, ethylene glycol dicyclopentyl ether, cyclohexyl, and naphthyl.

5. The method of claim 1 wherein the curable liquid composition include a compound having the following formula:

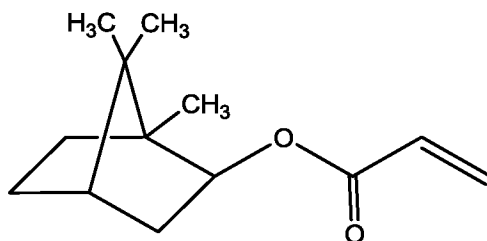

6. The method of claim 1 wherein the curable liquid composition includes a compound having the following formula II:

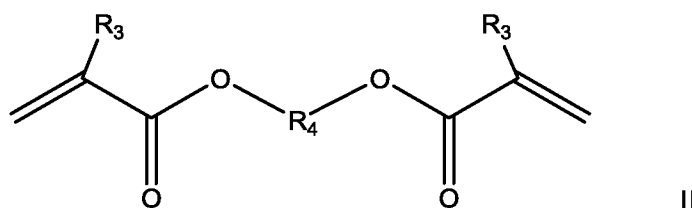

wherein R_3 is hydrogen or substituted or unsubstituted alkyl and R_4 is a hydrocarbon moiety.

7. The method of claim 3 wherein R_3 is hydrogen or methyl.

8. The method of claim 3 wherein R_4 is an alkylene group.

9. The method of claim 3 wherein R_4 is described by $-(CH_2)_n-$ and n is an integer from 1 to 10.

10. The method of claim 1 wherein the at least one acrylate has the following formula:

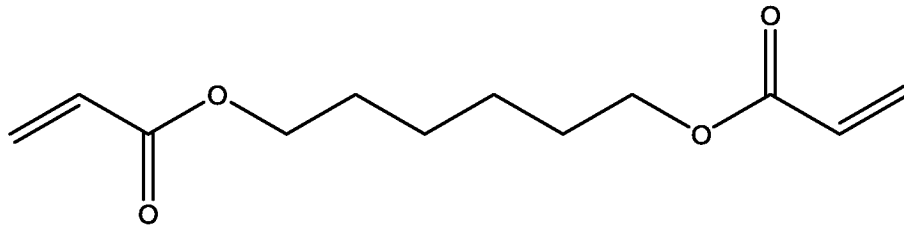

11. The method of claim 1 wherein step c) comprises

- d) depositing a metallic layer over the second imprint layer side;
- e) depositing a dielectric layer over the metallic layer;
- f) depositing a phase change layer over the first dielectric layer; and
- g) depositing a second dielectric layer over the phase change layer.

12. The method of claim 1 wherein the curable liquid composition is illuminated with ultraviolet light.

13. The method of claim 1 wherein the curable liquid composition is patterned onto the second substrate side by:

applying the curable liquid composition to the second substrate side to form a coated substrate; and

contacting the curable liquid composition on the coated substrate with an imprinter such that a curable liquid composition is patterned.

14. A method for forming an optical tape for data storage from a substrate film, the substrate film having a first substrate side and a second substrate side, the method comprising:

- a) patterning a curable liquid composition onto the second side of the substrate film by:

applying the curable liquid composition to the second substrate side to form a coated substrate; and
 contacting the curable liquid composition on the coated substrate with an imprinter such that a curable liquid composition is patterned;
 the curable liquid composition including a free radical photoinitiator and a polymerizable component including a compound having formula I and a compound having formula II:

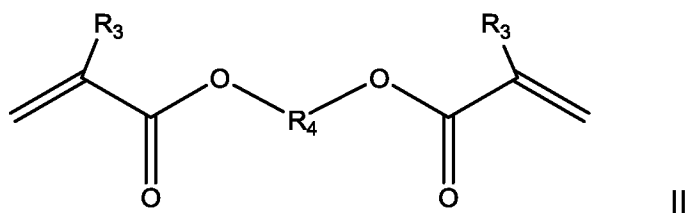
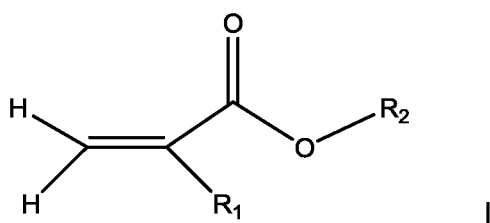

wherein:

R_1 is hydrogen or substituted or unsubstituted alkyl;

R_2 is a substituted or unsubstituted alkyl having more than 3 carbon atoms, cycloalkyl, cycloalkenyl, or substituted or unsubstituted aryl;

R_3 is hydrogen or substituted or unsubstituted alkyl; and

R_4 is a hydrocarbon moiety;

- b) illuminating the curable liquid composition to form a patterned imprint layer disposed over the substrate film, the imprint layer having a first imprint layer side and a second imprint layer side, the first imprint layer side being more proximate to the second substrate side than the second imprint layer side;
- c) placing a multilayer data recording assembly over the second imprint layer side;
- d) depositing a metallic layer over the second imprint layer side;

- e) depositing a dielectric layer over the metallic layer;
 - f) depositing a phase change layer over the first dielectric layer; and
 - g) depositing a second dielectric layer over the phase change layer.
15. The method of claim 14 wherein the metallic layer is deposited by sputtering.
16. The method of claim 14 wherein:
R₁ is hydrogen or methyl;
R₂ is isobornyl, phenyl, benzyl, dicyclopentenyl, dicyclopentenyl oxyethyl, ethylene glycol dicyclopentyl ether, cyclohexyl, and naphthyl;
R₃ is hydrogen or methyl; and
R₄ is an alkylene group.
17. The method of claim 14 wherein the curable liquid composition includes a compound having the following formula:

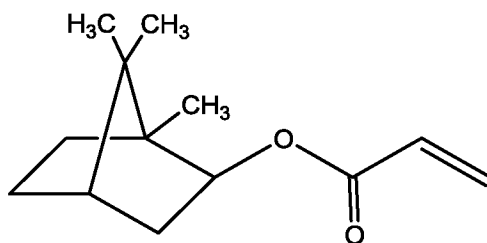

18. The method of claim 3 wherein R₄ is described by $-(\text{CH}_2)_n-$ and n is an integer from 1 to 10.
19. The method of claim 1 wherein the at least one acrylate has the following formula:

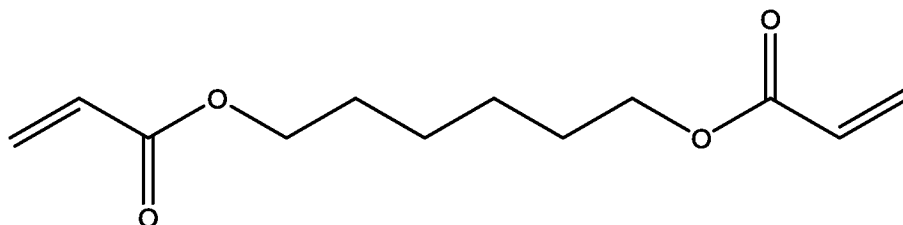

20. A polymeric imprint layer comprising residues of a free radical photoinitiator and a polymerizable component including a compound having formula I and a compound having formula II:

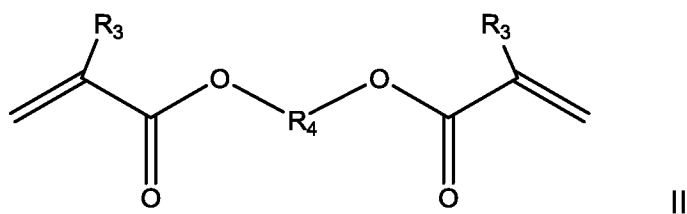
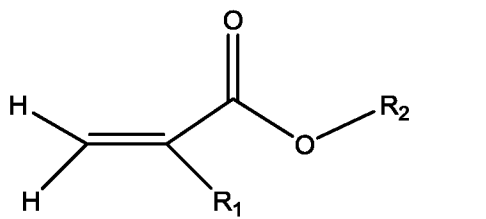

wherein:

R₁ is hydrogen or substituted or unsubstituted alkyl;

R₂ is a substituted or unsubstituted alkyl having more than 3 carbon atoms, cycloalkyl, cycloalkenyl, or substituted or unsubstituted aryl;

R₃ is hydrogen or substituted or unsubstituted alkyl; and

R₄ is a hydrocarbon moiety.

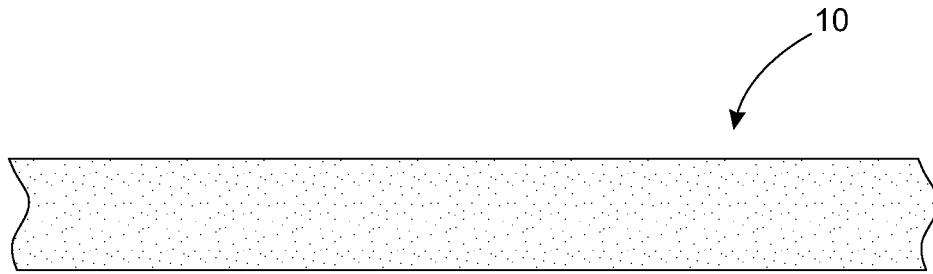

Fig. 1

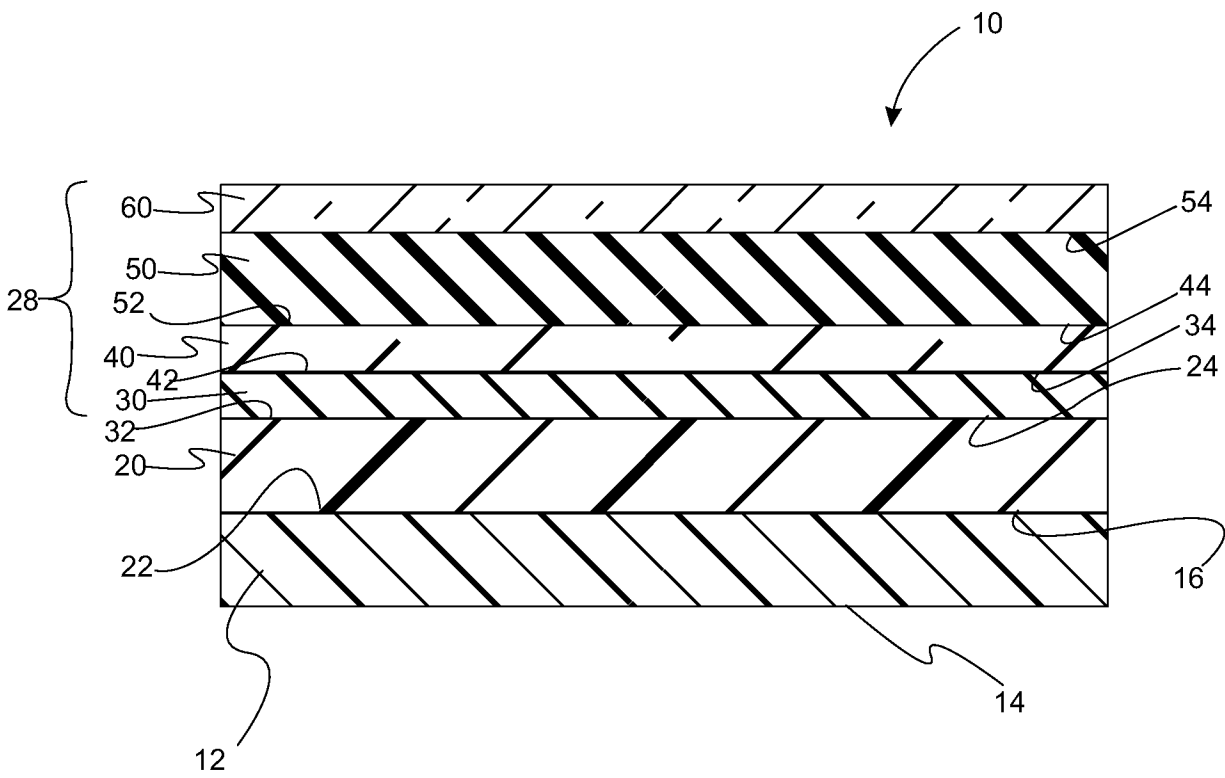

Fig. 2

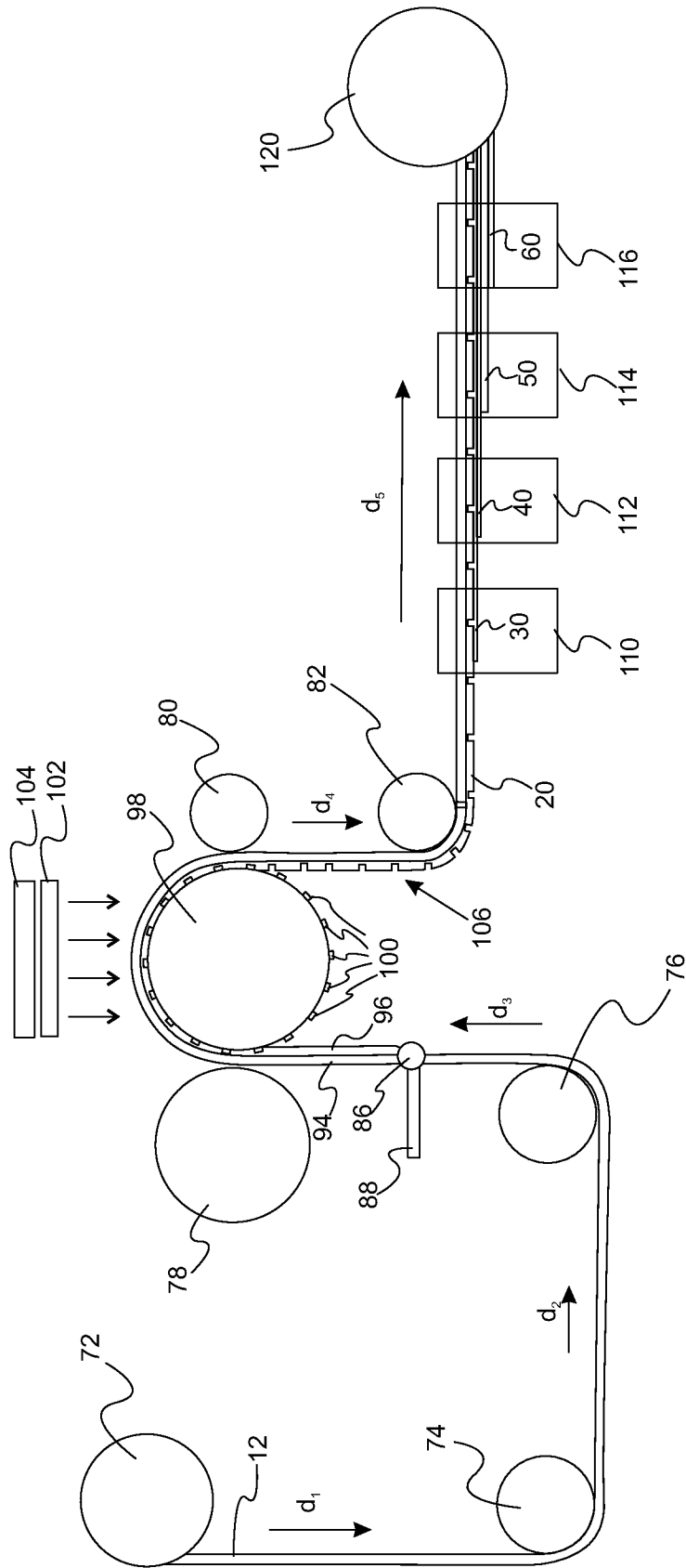

Fig. 3

INTERNATIONAL SEARCH REPORT

International application No
PCT/US2011/041737

A. CLASSIFICATION OF SUBJECT MATTER
INV. G11B7/252 G11B7/003
ADD.

According to International Patent Classification (IPC) or to both national classification and IPC

B. FIELDS SEARCHED

Minimum documentation searched (classification system followed by classification symbols)
G11B

Documentation searched other than minimum documentation to the extent that such documents are included in the fields searched

Electronic data base consulted during the international search (name of data base and, where practical, search terms used)

EPO-Internal

C. DOCUMENTS CONSIDERED TO BE RELEVANT

Category*	Citation of document, with indication, where appropriate, of the relevant passages	Relevant to claim No.
A	EP 0 519 629 A1 (ICI PLC [GB]) 23 December 1992 (1992-12-23) page 6, line 4 - line 11; figure 1; example 1	1
A	----- ANDREW J. STRANDJORD: "Flexible storage medium for write-once optical tape", PROCEEDINGS OF SPIE, vol. 1663, 1 January 1992 (1992-01-01), pages 362-371, XP55005325, ISSN: 0277-786X, DOI: 10.1117/12.137567 abstract -----	1

Further documents are listed in the continuation of Box C.

See patent family annex.

* Special categories of cited documents :

- "A" document defining the general state of the art which is not considered to be of particular relevance
- "E" earlier document but published on or after the international filing date
- "L" document which may throw doubts on priority claim(s) or which is cited to establish the publication date of another citation or other special reason (as specified)
- "O" document referring to an oral disclosure, use, exhibition or other means
- "P" document published prior to the international filing date but later than the priority date claimed

- "T" later document published after the international filing date or priority date and not in conflict with the application but cited to understand the principle or theory underlying the invention
- "X" document of particular relevance; the claimed invention cannot be considered novel or cannot be considered to involve an inventive step when the document is taken alone
- "Y" document of particular relevance; the claimed invention cannot be considered to involve an inventive step when the document is combined with one or more other such documents, such combination being obvious to a person skilled in the art.
- "&" document member of the same patent family

Date of the actual completion of the international search

22 August 2011

Date of mailing of the international search report

06/09/2011

Name and mailing address of the ISA/
European Patent Office, P.B. 5818 Patentlaan 2
NL - 2280 HV Rijswijk
Tel. (+31-70) 340-2040,
Fax: (+31-70) 340-3016

Authorized officer

Stabel, Andreas

INTERNATIONAL SEARCH REPORT

Information on patent family members

International application No

PCT/US2011/041737

Patent document cited in search report	Publication date	Patent family member(s)	Publication date
EP 0519629	A1	23-12-1992 JP 5174426 A	13-07-1993
