

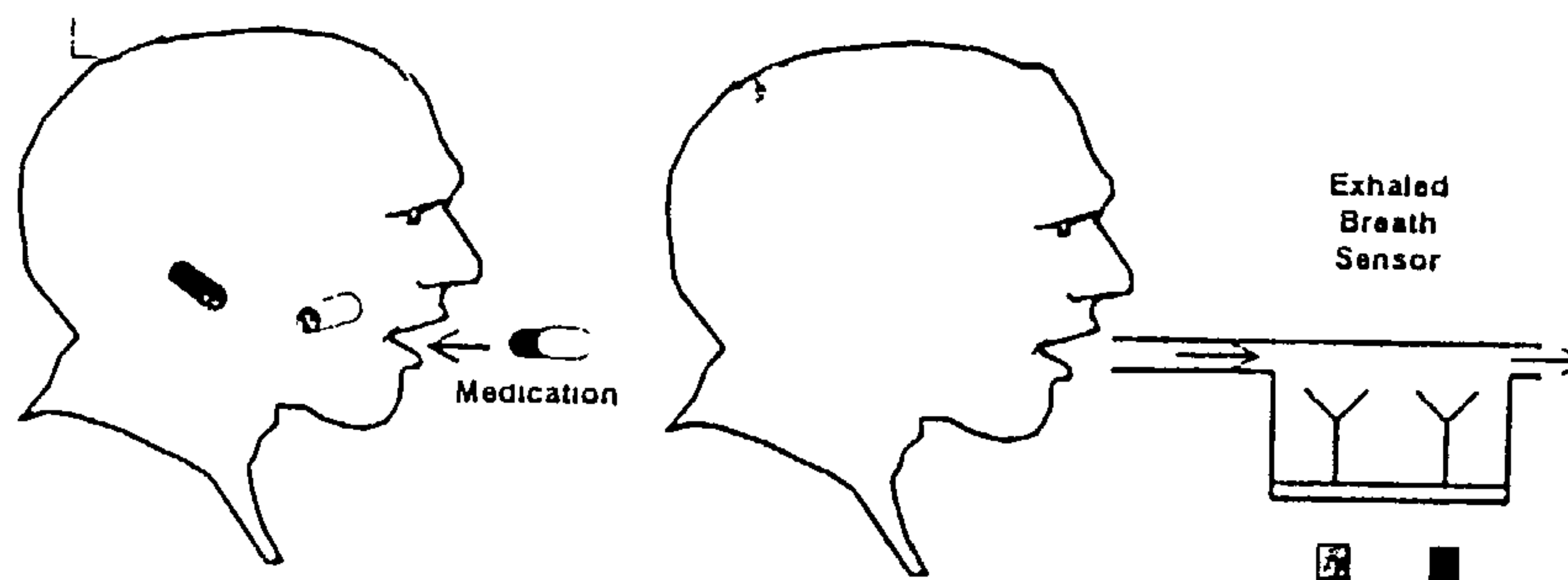

(86) Date de dépôt PCT/PCT Filing Date: 2000/11/08
 (87) Date publication PCT/PCT Publication Date: 2002/05/17
 (85) Entrée phase nationale/National Entry: 2002/05/07
 (86) N° demande PCT/PCT Application No.: US 2000/030692
 (87) N° publication PCT/PCT Publication No.: 2001/034024
 (30) Priorité/Priority: 1999/11/08 (60/164,250) US

(51) Cl.Int.⁷/Int.Cl.⁷ A61B 5/00, G01N 33/00
 (71) Demandeur/Applicant:
 UNIVERSITY OF FLORIDA RESEARCH FOUNDATION,
 INC., US
 (72) Inventeurs/Inventors:
 LAMPOTANG, SAMSUN, US;
 MELKER, RICHARD, US;
 TALTON, JAMES D., US;
 SILVERMAN, DAVID N., US
 (74) Agent: SIM & MCBURNEY

(54) Titre : PROCEDE DE DETECTION DE MARQUEUR ET APPAREIL DE SURVEILLANCE DE L'OBSERVANCE
 THERAPEUTIQUE DE MEDICAMENTS
 (54) Title: MARKER DETECTION METHOD AND APPARATUS TO MONITOR DRUG COMPLIANCE



(57) **Abrégé/Abstract:**

The present invention includes a method and apparatus for monitoring drug compliance by detecting markers, such as odors, upon exhalation by a patient after medication is taken, wherein such markers result either directly from the medication itself or from an additive combined with the medication. In the case of olfactory markers, the invention preferably utilizes electronic sensor technology, such as the commercial devices referred to as "artificial noses" or "electronic noses", to non-invasively monitor compliance. The invention further includes a reporting system capable of tracking compliance (remote or proximate) and providing the necessary alerts.

(12) INTERNATIONAL APPLICATION PUBLISHED UNDER THE PATENT COOPERATION TREATY (PCT)

CORRECTED VERSION

(19) World Intellectual Property Organization
International Bureau(43) International Publication Date
17 May 2001 (17.05.2001)

PCT

(10) International Publication Number
WO 01/34024 A1

- (51) International Patent Classification⁷: A61B 5/00, G01N 33/00
- (21) International Application Number: PCT/US00/30692
- (22) International Filing Date:
8 November 2000 (08.11.2000)
- (25) Filing Language: English
- (26) Publication Language: English
- (30) Priority Data:
60/164,250 8 November 1999 (08.11.1999) US
- (71) Applicant: UNIVERSITY OF FLORIDA RESEARCH FOUNDATION, INC. [US/US]; 223 Grinter Hall, Gainesville, FL 32611 (US).
- (72) Inventors: LAMPOTANG, Samsun; 3916 S.W. 98th Drive, Gainesville, FL 32608-4666 (US). MELKER, Richard; 6101 N.W. 19th Place, Gainesville, FL 32605-3247 (US). TALTON, James, D.; P.O. Box 13964, Gainesville, FL 32604-1964 (US). SILVERMAN, David, N.; 4721 N.W. 17th Place, Gainesville, FL 32605-3419 (US).
- (74) Agents: McLEOD, Christine, Q. et al.; Saliwanchik, Lloyd & Saliwanchik, Suite A-1, 2421 N.W. 41st Street, Gainesville, FL 32606 (US).
- (81) Designated States (*national*): AE, AG, AL, AM, AT, AU, AZ, BA, BB, BG, BR, BY, BZ, CA, CH, CN, CR, CU, CZ, DE, DK, DM, DZ, EE, ES, FI, GB, GD, GE, GH, GM, HR, HU, ID, IL, IN, IS, JP, KE, KG, KP, KR, KZ, LC, LK, LR, LS, LT, LU, LV, MA, MD, MG, MK, MN, MW, MX, MZ, NO, NZ, PL, PT, RO, RU, SD, SE, SG, SI, SK, SL, TJ, TM, TR, TT, TZ, UA, UG, UZ, VN, YU, ZA, ZW.
- (84) Designated States (*regional*): ARIPO patent (GH, GM, KE, LS, MW, MZ, SD, SL, SZ, TZ, UG, ZW), Eurasian patent (AM, AZ, BY, KG, KZ, MD, RU, TJ, TM), European patent (AT, BE, CH, CY, DE, DK, ES, FI, FR, GB, GR, IE, IT, LU, MC, NL, PT, SE, TR), OAPI patent (BF, BJ, CF, CG, CI, CM, GA, GN, GW, ML, MR, NE, SN, TD, TG).
- Published:
— with international search report
- (48) Date of publication of this corrected version:
10 May 2002

[Continued on next page]

(54) Title: MARKER DETECTION METHOD AND APPARATUS TO MONITOR DRUG COMPLIANCE

Patient Compliance Monitoring System

Overview

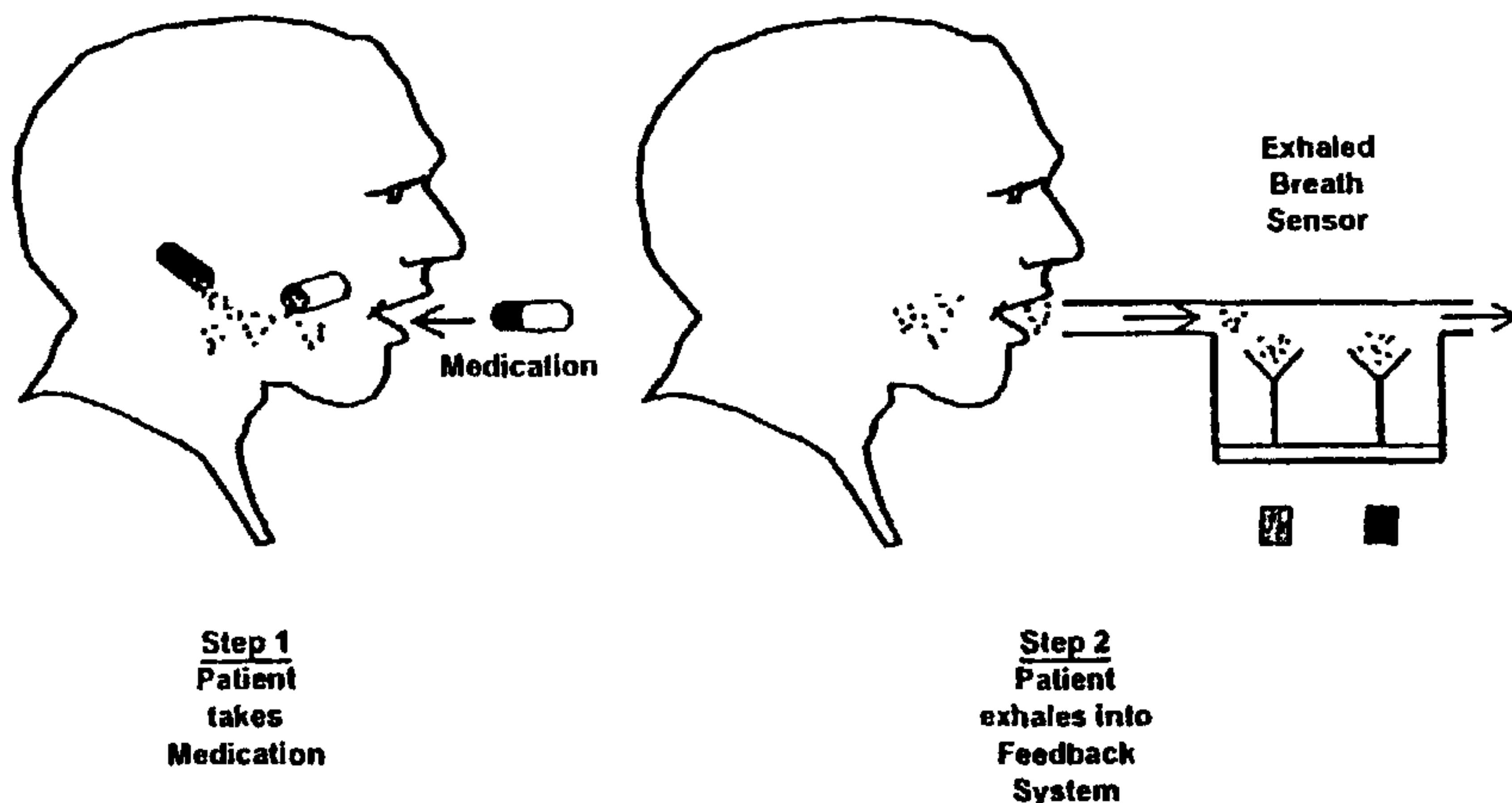

PCMS includes marker compound included in medication that is exhaled into detection system for accurate and reliable monitoring off-site

(57) Abstract: The present invention includes a method and apparatus for monitoring drug compliance by detecting markers, such as odors, upon exhalation by a patient after medication is taken, wherein such markers result either directly from the medication itself or from an additive combined with the medication. In the case of olfactory markers, the invention preferably utilizes electronic sensor technology, such as the commercial devices referred to as "artificial noses" or "electronic noses", to non-invasively monitor compliance. The invention further includes a reporting system capable of tracking compliance (remote or proximate) and providing the necessary alerts.

WO 01/34024 A1

DESCRIPTIONMARKER DETECTION METHOD AND APPARATUS
TO MONITOR DRUG COMPLIANCE

5

Cross-Reference to a Related Application

This application claims the benefit of U.S. Provisional Application No. 60/164,250, filed November 8, 1999.

10

Field of Invention

The present invention relates to marker detection, in the form of odors or the like, to monitor drug compliance, and, more particularly, to a method and apparatus for the detection of markers wherein such markers are detectable either directly from the medication itself or from an additive combined with the medication and are detected upon exhalation after medication is taken by a patient.

15

Background Information

Non-compliance of patients to drug regimens prescribed by their physicians results in excessive healthcare costs estimated to be around \$100 billion per year through lost work days, increased cost of medical care, higher complication rates, as well as drug wastage. Non-compliance refers to the failure to take the prescribed dosage at the prescribed time which results in undermedication or overmedication. In a survey of 57 non-compliance studies, non-compliance ranged from 15% to as high as 95% in all study populations, regardless of medications, patient population characteristics, drug being delivered or study methodology [Greenberg RN: Overview of patient compliance with medication dosing: A literature review. *Clinical Therapeutics*, 6(5):592-599, 1984].

20

25

The sub-optimal rates of compliance reported by various studies becomes of even greater concern as the American populace ages and becomes more dependent on drugs to fight the illnesses accompanying old age. By 2025, over 17% of the US population will be over 65 [Bell JA, May FE, Stewart RB: Clinical research in the elderly: Ethical and methodological considerations. *Drug Intelligence and Clinical Pharmacy*, 21: 1002-1007, 1987] and senior citizens take, on average, over three times as many drugs compared to the under 65 population [Cosgrove R: Understanding drug abuse in the elderly. *Midwife, Health Visitor & Community Nursing* 24(6):222-223, 1988]. The forgetfulness that sometimes accompanies old age also

30

makes it even more urgent to devise cost-effective methods of monitoring compliance on a large scale.

Further, non-compliance of patients with communicable diseases (e.g., tuberculosis and related opportunistic infections) costs the public health authorities millions of dollars annually and increases the likelihood of drug-resistance, with the potential for widespread dissemination of drug-resistant pathogens resulting in epidemics.

A cost-effective, but difficult to administer, program has been developed in seven locations around the nation to combat this serious threat to the American populace. It involves direct observation of all drug delivery by trained professionals (directly observed therapy: DOT) but is impractical for large scale implementation. Many techniques are also invasive, e.g., blood sampling.

Accordingly, there is a need in the art for a method to improve drug compliance which provides simple monitoring of medication dosing which is non-invasive, intuitive and sanitary.

15 Brief Summary of the Invention

The present invention solves the needs in the art by providing a method and apparatus for monitoring drug compliance by detecting markers, such as odors, upon exhalation by a patient after medication is taken, wherein such markers result either directly from the medication itself or from an additive combined with the medication. In the case of olfactory markers, the invention preferably utilizes electronic sensor technology, such as the commercial devices referred to as "artificial noses" or "electronic noses," to non-invasively monitor compliance. The invention further includes a reporting system capable of tracking compliance (remote or proximate) and providing the necessary alerts.

Therefore, it is an object of the present invention to detect marker substances as a measure of patient compliance by methods including, but not limited to, sensor technology (e.g., silicon chip technology) to non-invasively monitor compliance of patients to prescribed drug regimens.

It is a further object of the present invention to provide a reporting system capable of tracking compliance and alerting patients, healthcare personnel, and/or in some instances health officials of non-compliance.

The invention will now be described, by way of example and not by way of limitation, with reference to the accompanying sheets of drawings and other objects, features and advantages of the invention will be apparent from this detailed disclosure and from the appended claims. All patents, patent applications, provisional applications, and publications referred to

or cited herein, or from which a claim for benefit of priority has been made, are incorporated by reference in their entirety to the extent they are not inconsistent with the explicit teachings of this specification.

5 Brief Description of the Drawings

Figure 1 shows a gas sensor chip which may be utilized as the sensor for the present invention.

Figure 2 shows an overview of the preferred steps of the method of the present invention.

10 Figure 3 shows the patient taking medication with a marker which is released for detection.

Figure 4 shows the preferred marker detection system utilizing sensor technology which can communicate with a computer for proximate or remote monitoring.

15 Detailed Description of the Invention

The present invention provides a method and apparatus for monitoring drug compliance by detecting markers released for detection upon exhalation after medication is taken by a patient. The detected markers are derived either directly from the medication itself or from a novel additive combined with the medication (referred to herein as "markers"). Such markers
20 preferably include olfactory markers (odors) as well as other substances and compounds which may be detectable by various methods, as described in more detail herein. Throughout this disclosure the marker or marker substance is defined as a substance added to the medication or taken with the medication (i.e., as the coating on a pill) that is detected by means of its physical or chemical properties as an indication that the patient has taken the medication. This includes
25 the use of the medication itself as its own marker. The marker substance is then detected by devices including but not limited to electronic noses, spectrophotometers to detect the marker's IR, UV, or visible absorbance or fluorescence, or mass spectrometers to detect the marker's characteristic mass display.

Gas Sensor Technology

30 The invention preferably utilizes gas sensor technology, such as the commercial devices referred to as "artificial noses" or "electronic noses," to non-invasively monitor compliance. Electronic noses have been used mostly in the food, wine and perfume industry where their sensitivity makes it possible to distinguish between grapefruit oil and orange oil and identify spoilage in perishable foods before the odor is evident to the human nose. There has been little

medical-based research and application; however, recent examples demonstrate the power of this non-invasive technique. Electronic noses have determined the presence of bacterial infection in the lungs simply by analyzing the exhaled gases of patients for odors specific to particular bacteria [Hanson CW, Steinberger HA: The use of a novel electronic nose to diagnose the presence of intrapulmonary infection. *Anesthesiology*, V87, No. 3A, Abstract A269, Sep. 1997].
5 Also a genitourinary clinic has utilized an electronic nose to screen for, and detect bacterial vaginosis, with a 94% success rate after training [Chandiok S, et al.: Screening for bacterial vaginosis: a novel application of artificial nose technology. *Journal of Clinical Pathology*, 50(9):790-1, 1997]. Specific bacterial species can also be identified with the electronic nose
10 based on special odors produced by the organisms [Parry AD et al.: Leg ulcer odor detection identifies beta-haemolytic streptococcal infection. *Journal of Wound Care*, 4:404-406, 1995].

A number of patents which describe gas sensor technology include the following: US5945069 to *Buchler*, entitled "Gas sensor test chip"; US5918257 to *Mifsud* et al., entitled "Method and devices for the detection of odorous substances and applications"; US4938928 to
15 *Koda* et al., entitled "Gas sensor"; US4992244 to *Grate*, entitled "Films of dithiolene complexes in gas-detecting microsensors"; US5034192 to *Wrighton* et al., entitled "Molecule-based microelectronic devices"; US5071770 to *Kolesar, Jr.*, entitled "Method for gaseous component identification with #3 polymeric film"; US5145645 to *Zakin* et al., entitled "Conductive polymer selective species sensor"; US5252292 to *Hirata* et al., entitled "Ammonia sensor";
20 US5605612 to *Park* et al., entitled "Gas sensor and manufacturing method of the same"; US5756879 to *Yamagishi* et al., entitled "Volatile organic compound sensors"; US5783154 to *Althainz* et al., entitled "Sensor for reducing or oxidizing gases"; and US5830412 to *Kimura* et al., entitled "Sensor device, and disaster prevention system and electronic equipment each having sensor device incorporated therein," all of which are incorporated herein by reference in
25 their entirety.

Numerous methods for the detection of marker substances as known in the art may be utilized in the method of the present invention. For example, gas chromatography, which consists of a method of selective detection by separating the molecules of gas compositions, may be used as a way of monitoring markers. Another example of detection contemplated by the
30 present invention includes transcutaneous/transdermal detection, such as that disclosed in U.S. Patent No. 5,771,890 to *Tamada* and U.S. Patent No. 5,954,685 to *Tierney* and the commercial device utilizing reverse iontophoresis sold by Cygnus, Inc. under the trademark "Glucowatch®," the disclosures of which are incorporated herein by reference. Marker detection of the present invention through body fluids as known in the art such as sweat, saliva,

urine, mucous, hair, nails, tears, and other bodily discharge are also contemplated herein (e.g., via ion exchange dipstick in combination with stain-producing agent, filtering fluids and treating with binding agent and reagents for color reaction, spectrophotometers, and the like). Recent developments in the field of detection of marker substances include, but are not limited to, 5 semiconductive gas sensors, mass spectrometers, IR or UV or visible or fluorescence spectrophotometers. The marker substances change the electrical properties of the semiconductors by making their electrical resistance vary, and the measurement of these variations allows one to determine the concentration of marker substances. These methods and apparatus used for detecting marker substances use a relatively brief detection time, of around 10 a few seconds, compared to those given by gas chromatography, which takes from several minutes to several hours. Other recent gas sensor technologies contemplated by the present invention include apparatus having conductive-polymer gas-sensors (“polymeric”) and apparatus having surface-acoustic-wave (SAW) gas-sensors.

The conductive-polymer gas-sensors (also referred to as “chemoresistors”) have a film 15 made of a conductive polymer sensitive to the molecules of odorous substances. On contact with the molecules, the electric resistance of the sensors change and the measurement of the variation of this resistance enables the concentration of the odorous substances to be determined. An advantage of this type of sensor is that it functions at temperatures close to room temperature. One can also obtain, according to the chosen conductive polymer, different sensitivities for 20 detecting different odorous substances.

Polymeric gas sensors can be built into an array of sensors, where each sensor is designed to respond differently to different gases and augment the selectivity of the odorous substances.

The surface-acoustic-wave (SAW) gas-sensors generally include a substrate with 25 piezoelectric characteristics covered by a polymer coating which is able to selectively absorb the odorous substances. The variation of the resulting mass leads to a variation of its resonant frequency. This type of sensor allows for very good mass-volume measures of the odorous substances. In the SAW device, the substrate is used to propagate a surface acoustic wave between sets of interdigitated electrodes. The chemoselective material is coated on the surface 30 of the transducer. When a chemical analyte interacts with a chemoselective material coated on the substrate, the interaction results in a change in the SAW properties such as the amplitude of velocity of the propagated wave. The detectable changes in the characteristics of the wave indicates the presence of the chemical analyte. SAW devices are described in numerous patents and publications, including U.S. Patent No. 4,312,228 to *Wohltjen* and U.S. Patent No. 4,895,017

to Pyke, and Groves WA, et al.: Analyzing organic vapors in exhaled breath using surface acoustic wave sensor array with preconcentration: Selection and characterization of the preconcentrator adsorbent, *Analytica Chimica Acta* 371 (1988) 131-143, all of which are incorporated herein by reference. Other types of chemical sensors known in the art that use chemoselective coatings applicable to the operation of the present invention include bulk acoustic wave (BAW) devices, plate acoustic wave devices, interdigitated microelectrode (IME) devices, and optical waveguide (OW) devices, electrochemical sensors, and electrically conducting sensors.

The operating performance of a chemical sensor that uses a chemoselective film coating is greatly affected by the thickness, uniformity and composition of the coating. For these biosensors, increasing the coating thickness, has a detrimental effect on the sensitivity. Only the portion of the coating immediately adjacent to the transducer substrate is sensed by the transducer. If the polymer coating is too thick, the sensitivity of the SAW device to record changes in frequency will be reduced. These outer layers of coating material compete for the analyte with the layers of coating being sensed and thus reduce the sensitivity of the biosensor. Uniformity of the coating is also a critical factor in the performance of a sensor that uses a chemoselective coating since changes in average surface area greatly effect the local vibrational signature of the SAW device. Therefore, films should be deposited that are flat to within 1 nm with a thickness of 15 - 25 nm. In this regard, it is important not only that the coating be uniform and reproducible from one device to another, so that a set of devices will all operate with the same sensitivity, but also that the coating on a single device be uniform across the active area of the substrate. If a coating is non-uniform, the response time to analyte exposure and the recovery time after analyte exposure are increased and the operating performance of the sensor is impaired. The thin areas of the coating respond more rapidly to an analyte than the thick areas. As a result, the sensor response signal takes longer to reach an equilibrium value, and the results are less accurate than they would be with a uniform coating.

Most current technologies for creating large area films of polymers and biomaterials involve the spinning, spraying, or dipping of a substrate into a solution of the macromolecule and a volatile solvent. These methods coat the entire substrate without selectivity and sometimes lead to solvent contamination and morphological inhomogeneities in the film due to non-uniform solvent evaporation. There are also techniques such as microcontact printing and hydrogel stamping that enable small areas of biomolecular and polymer monolayers to be patterned, but separate techniques like photolithography or chemical vapor deposition are needed to transform these films into microdevices. Other techniques such as thermal evaporation and

pulsed laser ablation are limited to polymers that are stable and not denatured by vigorous thermal processes. More precise and accurate control over the thickness and uniformity of a film coating may be achieved by using pulsed laser deposition (PLD), a physical vapor deposition technique that has been developed recently for forming ceramic coatings on substrates. By this method, a target comprising the stoichiometric chemical composition of the material to be used for the coating is ablated by means of a pulsed laser, forming a plume of ablated material that becomes deposited on the substrate.

Polymer thin films, using a new laser based technique developed by researchers at the Naval Research Laboratory called Matrix Assisted Pulsed Laser Evaporation (MAPLE), have recently been shown to increase sensitivity and specificity of chemoselective Surface Acoustic Wave vapor sensors. A variation of this technique, Pulsed Laser Assisted Surface Functionalization (PLASF) is preferably used to design compound specific biosensor coatings with increased sensitivity for the present invention. PLASF produces similar thin films for sensor applications with bound receptors or antibodies for biosensor applications. By providing improved SAW biosensor response by eliminating film imperfections induced by solvent evaporation and detecting molecular attachments to specific antibodies, high sensitivity and specificity is possible.

Certain extremely sensitive, commercial off-the-shelf (COTS) electronic noses, such as those provided by Cyrano Sciences, Inc. ("CSI") (e.g., CSI's Portable Electronic Nose and CSI's Nose-Chip™ integrated circuit for odor-sensing -- U.S. Patent No. 5,945,069 -- Figure 1), are preferred in the present invention to monitor the exhaled breath from a patient to detect medication dosing. These devices offer minimal cycle time, can detect multiple odors, can work in almost any environment without special sample preparation or isolation conditions, and do not require advanced sensor design or cleansing between tests.

Other technologies and methods are contemplated herein for detection of markers. For example, a patient's breath can be captured into a container (vessel) for later analysis at a central instrument such as a mass spectrometer.

The present invention will determine if a patient has taken the prescribed drug at the appropriate time and at the prescribed dosage by monitoring and analyzing the exhaled gases with the electronic nose. In a preferred embodiment, the device of the present invention is designed so that patients can exhale via the mouth or nose directly into the device. The device is designed to detect the presence of medications and/or harmless olfactory markers added to medication (discussed hereinafter).

Another preferred electronic nose technology of the present invention comprises an array of polymers, for example, 32 different polymers, each exposed to a marker (e.g., odor). Each of the 32 individual polymers swells differently to the odor creating a change in the resistance of that membrane and generating an analog voltage in response to that specific odor
5 (“signature”). The normalized change in resistance can then be transmitted to a processor to identify the type, quantity, and quality of the odor based on the pattern change in the sensor array. The unique response results in a distinct electrical fingerprint that is used to characterize the odor. The pattern of resistance changes of the array is diagnostic of the sample, while the amplitude of the pattern indicates the concentration of the sample.

10 The responses of the electronic nose to specific odors can be fully characterized using a combination of conventional gas sensor characterization techniques. For example, the sensor can be attached to a computer. Marker analysis results can be displayed on the computer screen, stored, transmitted, etc. A data analyzer can compare a pattern of response to previously measured and characterized responses from known markers. The matching of those patterns can
15 be performed using a number of techniques, including neural networks. By comparing the analog output from each of the 32 polymers to a “blank” or control odor, for example, a neural network can establish a pattern which is unique to that marker and subsequently learns to recognize that marker. The particular resistor geometries are selected to optimize the desired response to the particular marker being sensed. The electronic nose of the present invention is preferably a self-
20 calibrating polymer system suitable for liquid or gas phase biological solutions for a variety of medications simultaneously.

The electronic nose of the present invention might include integrated circuits (chips) manufactured in a modified vacuum chamber for Pulsed Laser Deposition of polymer coatings. It will operate the simultaneous thin-film deposition wave detection and obtain optimum
25 conditions for high sensitivity of SAW sensors. The morphology and microstructure of biosensor coatings will be characterized as a function of process parameters.

The electronic nose used in the present invention will preferably be modified so that patients can exhale directly into the device. For example, a mouthpiece or nosepiece will be provided for interfacing a patient with the device to readily transmit the exhaled breath to the
30 sensor (See, e.g., U.S. Patent No. 5,042,501). The output from the neural network of the modified electronic nose should be similar when the same patient exhales directly into the device and when the exhaled gases are allowed to dry before they are sampled by the electronic nose.

The humidity in the exhaled gases represents a problem for certain electronic nose devices (albeit not SAW sensors) which only work with “dry” gases. When using such humidity

sensitive devices, the present invention will adapt such electronic nose technology so that a patient can exhale directly into the device with a means to dehumidify the samples. This will be accomplished by including a commercial dehumidifier or a heat moisture exchanger (HME), a device designed to prevent desiccation of the airway during ventilation with dry gases.

5 Alternatively, the patient may exhale through their nose which is an anatomical, physiological dehumidifier to prevent dehydration during normal respiration.

Medication Markers

Upon ingestion of a drug with or without an olfactory coating or additive (see herein), detection can occur under three distinct circumstances. In one, the drug and/or the additive or coating can "coat" or persist in the mouth, esophagus and/or stomach upon ingestion and be detected upon exhalation (similar to the taste or flavor that remains in the mouth after eating a breath mint). In a second instance, the olfactory coating or additive (or the drug) may react in the mouth or stomach with acid or enzymes to produce or liberate the marker that can then be detected with a "burp" or upon exhalation. Thirdly, the drug and/or marker additive can be absorbed in the gastrointestinal tract and be excreted in the lungs (i.e. alcohol is rapidly absorbed and detected with a Breathalyzer). Generally, a non-toxic marker (that can be detected by its chemical or physical properties) added to the medication itself or to the pill or its coating or to the solution of suspension of the medication or taken separately in some form with the medication will provide a method to determine if the drug was taken as prescribed.

10
15

20 While detection is possible by all three mechanisms, drug excretion from the lungs after oral ingestion usually takes longer. Rapid detection after ingestion is preferable so that the patient does not have to wait to perform the test after taking the drug.

However, there may be instances where detection after excretion from the lungs is preferable. This may be the case when a marker or olfactory marker is added to a medication that is given by the intravenous route. Under these circumstances, excretion may occur rapidly since intravenously injected medications pass rapidly to the lungs and can be excreted.

25

Thus, when a drug is ingested by a patient, the preferred embodiment of the invention detects the presence of that drug almost immediately in the exhaled breath of the patient (or possibly by requesting the patient to deliberately produce a burp) using the electronic nose. Certain drug compositions might not be detectable in the exhaled breath. Others might have a coating to prevent the medication from dissolving in the stomach. In both instances, as an alternate embodiment, a non-toxic olfactory marker (e.g., volatile organic vapors) added to the coating of the pill or in a separate fast dissolving compartment in the pill or the solution (if the medication is in liquid or suspension form) will provide a method to determine if the drug was

30

taken as prescribed. Any number of benign compounds could be used as olfactory markers. Preferably the marker substance will coat the oral cavity or esophagus or stomach for a short while and be exhaled in the breath or in a burp. The electronic nose will determine their presence as well as their concentration. For pills, capsules, and fast-dissolving tablets the markers can be applied as coatings or physically combined or added to the medication. Markers can also be included with liquid medications and inhalers or other dosing means. In use, the electronic nose of the present invention will identify predetermined non-toxic olfactory markers as well as those drugs that can be directly detected without olfactory markers. The electronic noses will not only detect different drugs but also drug concentrations.

10 Preferably, in operation, the electronic nose will be used to identify a baseline marker spectrum for the patient prior to ingestion of the medication, if necessary. This will prove beneficial for the detection of more than one drug if the patient is required to ingest more than one drug at a time and possible interference from different foods and odors in the stomach, mouth, esophagus and lungs.

15 The substances referred to as "olfactory markers" herein are detected by their physical and/or chemical properties, which does not preclude using the medication itself as its own marker. Preferable markers include, but are not limited to, the following: trans-Anethole (1-methoxy-4-propenylbenzene) - anise; Benzaldehyde (benzoic aldehyde) - bitter almond; Butyl isobutyrate (n-butyl 2, methyl propanoate) - pineapple; Cinnamaldehyde (3-phenylpropenal) - cinnamon; Citral (2-trans-3, 7-dimethyl-2, 6-octadiene-1-al) - citrus; Menthol (1-methyl-4-isopropylcyclohexane-3-ol) - menthol; and alpha-Pinene (2, 6, 6-trimethylbicyclo-(3,1,1)-2-heptene) - pine. These markers are preferred since they are used in the food industry as flavor ingredients and are permitted by the Food and Drug Administration as indicated in the Code of Federal Regulations, Chapter 21, et. sec. Moreover, these markers are classified "generally recognized as safe" by the Flavor and Extract Manufacturer's Association. These markers are also all natural products and single individual compounds, not mixtures, to enhance detection and represent a variety of chemical structures to enhance differentiation in detection devices. They are generally poorly soluble in water which enhances their volatility and detection in the breath.

30 Obviously, the number of marker substances that could be used is vast (Reference: Fenaroli's Handbook of Flavor Ingredients, 3rd edition, CRC Press, Boca Raton, 1995) and use of such other applicable markers is contemplated herein.

To effectively use the olfactory markers, preferably, the medication (e.g., capsules, tablets, gel-caps) is coated with a known marker substance along with rapidly dissolving glucose

and/or sucrose (i.e., the pill is coated with the marker in air-flocculated sugar crystals). This would stimulate salivation and serve to spread the marker around the oral cavity, enhancing the lifetime in the cavity. Since the throat and esophagus are also coated with the marker as the medication is swallowed, detection is further enhanced.

5 Preferably the device will utilize predetermined signature profiles of specific drugs, classes of drugs, and/or selected markers. The markers could be used for specific drugs or for a class of drugs. For example, a patient may be taking an antibiotic, an antihypertensive agent, and an anti-reflux drug. One marker could be used for antibiotics as a class, or for subclasses of antibiotics, such as erythromycins. Another marker could be used for antihypertensives as a
10 class, or for specific subclasses of antihypertensives, such as calcium channel blockers. The same would be true for the anti-reflux drug. Furthermore, combinations of marker substances could be used allowing a rather small number of markers to specifically identify a large number of medications.

When the drugs or drugs coated with selected markers are taken (Figure 2), the drugs
15 are dissolved in the mouth (or digested in the stomach, transmitted to the lungs, etc.). The electronic nose can then detect the marker from the drugs or drugs coated with selected markers when the patient exhales (Figures 2 - 4) to confirm that the medication was taken on a dose by dose basis. The electronic nose can record and/or transmit the data sensed from the patient's breath for monitoring purposes.

20 While the primary goal of the invention is to improve and document medication compliance in motivated, responsible (albeit occasionally forgetful) individuals, there is a small minority of patients who intentionally do not take their medications, or whose failure to take their medication can result in a public health crisis (i.e. the spread of drug resistant tuberculosis).
As a further guarantee that these individuals do not use deceptive practices to "fool" the sensors
25 (i.e. dissolving the tablet or capsules in a small amount of water to release the marker), a pressure sensor can be incorporated into the detector to document that the patient is actually exhaling through the device. A flow restrictor can be incorporated which increases the resistance to exhalation. By the simple addition of a pressure transducer to the system, a pressure change from baseline can be measured during exhalation. Additionally, a number of detectors are
30 available (i.e. end-tidal carbon dioxide monitors) that can be added to the device for use in environments where deception may be likely (i.e. institutions and prisons) and the consequences severe.

Additional embodiments are also envisioned herein. Pulmonary delivery of medications is well known, especially for conditions such as asthma and chronic obstructive pulmonary

disease. In these instances, medication (i.e. corticosteroids, bronchodilators, anticholinergics, etc.) is often nebulized or aerosolized and inhaled through the mouth directly into the lungs. This allows delivery directly to the affected organ (the lungs) and reduces side effects common with enteral (oral) delivery. Metered dose inhalers (MDIs) or nebulizers are commonly used to
5 deliver medication by this route. Recently dry powder inhalers have become increasingly popular, as they do not require the use of propellants such as CFCs. Propellants have been implicated in worsening asthma attacks, as well as depleting the ozone layer. Dry power inhalers are also being used for drugs that were previously given only by other routes, such as insulin, peptides, and hormones.

10 Olfactory markers can be added to these delivery systems as well. Since the devices are designed to deliver medication by the pulmonary route, the sensor array can be incorporated into the device and the patient need only exhale back through the device for documentation to occur.

Lastly, devices are available to deliver medication by the intranasal route. This route is often used for patients with viral infections or allergic rhinitis, but is being increasingly used to
15 deliver peptides and hormones as well. Again, it would be simple to incorporate a sensor array into these devices, or the patient can exhale through the nose for detection by a marker sensing system.

The electronic nose and/or computer communicating therewith (Figure 4) can also notify the medical staff and/or the patient to any irregularities in dosing, dangerous drug interactions, and the like. This system will enable determination as to whether a patient has taken the
20 prescribed drug at the appropriate time and at the prescribed dosage. The device could also alert the patient that it is time to take their medications.

Remote Communication System

A further embodiment of the invention includes a communications device in the home
25 (or other remote location) that will be interfaced to the electronic nose. The home communications device will be able to transmit immediately or at prescribed intervals directly or over a standard telephone line (or other communication means) the data collected by the compliance monitoring device. The communication of the data will allow the physician to be able to remotely verify if the patient took the prescribed drug at the prescribed time and dose.
30 The data transmitted from the home can also be downloaded to a computer where the prescribed drug regimen is stored in a database, and any deviations within limits from the prescribed drug regimen would be automatically flagged (e.g., alarm) so that a home care nurse could telephone the patient and inquire about the reasons for deviating from the prescribed drug regimen.

It should be understood that the examples and embodiments described herein are for illustrative purposes only and that various modifications or changes in light thereof will be suggested to persons skilled in the art and are to be included within the spirit and purview of this application and the scope of the appended claims. Specifically, the marker detection method of the present invention is intended to cover detection not only through the exhalation by a patient with a device utilizing electronic nose technology, but also other suitable technologies, such as gas chromatography, transcutaneous/transdermal detection, semiconductive gas sensors, mass spectrometers, IR or UV or visible or fluorescence spectrophotometers. The invention also includes marker detection not only through a patient's exhaled breath, but also through sweat, saliva, urine, mucous, hair, nails, tears, and other bodily discharge of the patient.

Claims

1 1. A method of determining patient compliance, comprising
2 providing a medication with a detectable marker to be taken by the patient, and
3 subsequently analyzing the patient's breath to confirm the presence of said marker and
4 thus the taking of said medication.

1 2. The method of claim 1 wherein the medication itself comprises said detectable
2 marker.

1 3. The method of claim 1 wherein the marker is an odorous substance.

1 4. The method of claim 3 wherein the patient's breath is analyzed to confirm the
2 presence of said marker by sensor technology selected from semiconductor gas sensor
3 technology, conductive polymer gas sensor technology, or surface acoustic wave gas sensor
4 technology.

1 5. The method of claim 4 wherein the sensor technology produces a unique electronic
2 fingerprint to characterize the marker such that the presence and concentration of the marker is
3 determined.

1 6. The method of claim 1 wherein the marker is a flavor ingredient selected from trans-
2 Anethole (1-methoxy-4-propenyl benzene) - anise; Benzaldehyde (benzoic aldehyde) - bitter
3 almond; Butyl isobutyrate (n-butyl 2, methyl propanoate) - pineapple; Cinnamaldehyde (3-
4 phenylpropenal) - cinnamon; Citral (2-trans-3, 7-dimethyl-2, 6-octadiene-1-al) - citrus;
5 Menthol (1-methyl-4-isopropylcyclohexane-3-ol) - menthol; and alpha-Pinene (2, 6, 6-
6 trimethylbicyclo-(3,1,1)-2-heptene) - pine.

1 7. The method of claim 1 wherein the patient's breath is analyzed to confirm the
2 presence of said marker by a spectrophotometer.

1 8. The method of claim 1 wherein the patient's breath is analyzed to confirm the
2 presence of said marker by a mass spectrometer.

1 9. The method of claim 1 wherein the marker is an additive combined with the
2 medication.

1 10. The method of claim 1 wherein the marker is a coating on the medication.

1 11. The method of claim 10 wherein a substance to stimulate salivation is included with
2 the marker.

1 12. The method of claim 1 wherein the marker is included with a liquid medication.

1 13. The method of claim 1 wherein the marker is included with a pulmonary delivered
2 medication.

1 14. The method of claim 1 wherein the marker is included with an intranasal delivered
2 medication.

1 15. The method of claim 1 wherein the marker is included with intravenously delivered
2 medication.

1 16. The method of claim 1 further comprising the step of recording data resulting from
2 analysis of the patient's breath.

1 17. The method of claim 1 further comprising the step of transmitting data resulting
2 from analysis of the patient's breath.

1 18. The method of claim 1 wherein the analysis of the patient's breath includes
2 comparing the marker sensed in the patient's breath with a predetermined signature profile of
3 a specific marker.

1 19. The method of claim 18 wherein the predetermined signature profile of a specific
2 marker is associated with a specific drug.

1 20. The method of claim 18 wherein the predetermined signature profile of a specific
2 marker is associated with a class of drugs.

1 21. The method of claim 1 further comprising the step of capturing the patient's breath
2 in a vessel prior to analysis.

1 22. The method of claim 1 further comprising the step of dehumidifying the patient's
2 breath prior to analysis.

1 23. The method of claim 1 wherein the marker first reacts with enzymes in the patient's
2 mouth to be detectable.

1 24. The method of claim 1 wherein the marker first reacts with acids in the patient's
2 stomach to be detectable.

1 25. The method of claim 1 wherein the marker is absorbed in the patient's
2 gastrointestinal tract and excreted in the lungs.

1 26. The method of claim 1 wherein the data resulting from analysis of the patient's
2 breath includes marker concentration and, thus, medication concentration.

1 27. The method of claim 1 further comprising the step of identifying a baseline marker
2 spectrum for the patient prior to the patient's taking of the medication.

1 28. The method of claim 1 wherein said analysis further includes detecting exhalation
2 of the patient's breath with a sensor.

1 29. A method of determining patient compliance, comprising
2 providing a medication with a detectable marker to be taken by the patient, and
3 subsequently analyzing the patient utilizing transdermal detection to confirm the
4 presence of said marker and thus the taking of said medication.

1 30. A method of determining patient compliance, comprising
2 providing a medication with a detectable marker to be taken by the patient, and

3 subsequently analyzing the patient utilizing reverse iontophoresis detection to confirm
4 the presence of said marker and thus the taking of said medication.

1 31. A method of producing medication which is detectable for patient compliance,
2 comprising
3 identifying a detectable marker substance, and
4 producing a medication combined with said detectable marker substance to be taken by
5 the patient whereby subsequent analysis of the patient's breath will confirm the presence of said
6 marker substance and thus the taking of said medication.

1 32. An apparatus for rapidly determining patient compliance with medications, said
2 medications having marker substances associated therewith, comprising

3 (a) a sensor having a surface exposed to the patient's breath and comprising a material
4 selectively absorptive of a group of chemical substances of which said marker substance is a
5 member;

6 (b) analysis means, coupled to the sensor, for producing an electrical signal indicative
7 of the presence of said marker substance.

1 33. The apparatus of claim 32, wherein the analysis means are further operative to
2 determine the approximate concentration of the marker substance.

1 34. The apparatus of claim 33, wherein the sensor comprises a surface acoustic wave
2 device.

1 35. An apparatus for rapidly determining patient compliance with medications, said
2 medications having marker substances associated therewith comprising:

3 (a) means for receiving air exhaled by the patient; and

4 (b) means for measuring the marker substance concentration in said exhaled air.

1 36. The apparatus of claim 35 wherein said means for measuring the marker substance
2 comprises sensor technology selected from semiconductor gas sensor technology, conductive
3 polymer gas sensor technology, or surface acoustic wave gas sensor technology.

1 37. The method of claim 1 wherein the marker is included with transdermally delivered
2 medication.

1 38. A method of detecting medication in a patient comprising:
2 analysing the patient's breath to detect the presence of a predetermined marker; and
3 identifying the medication in the patient which is associated with the detected marker.

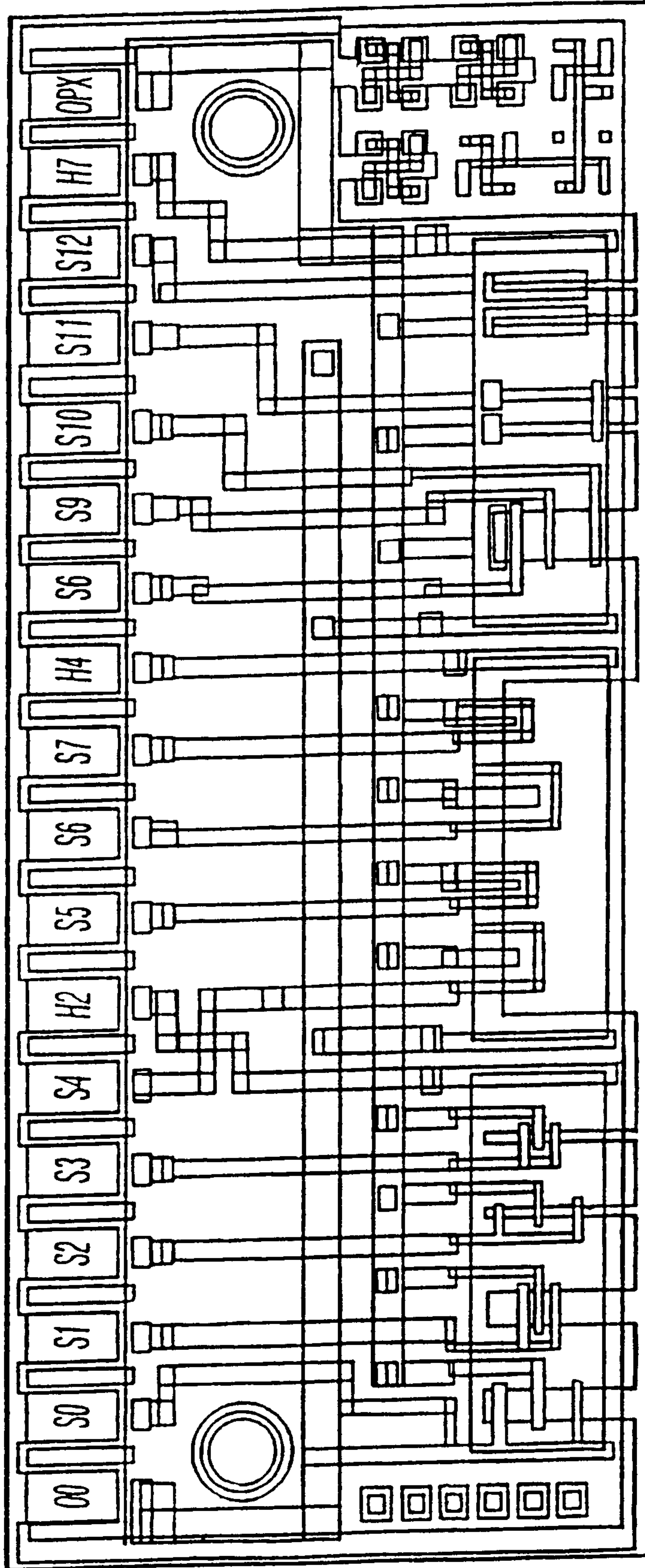
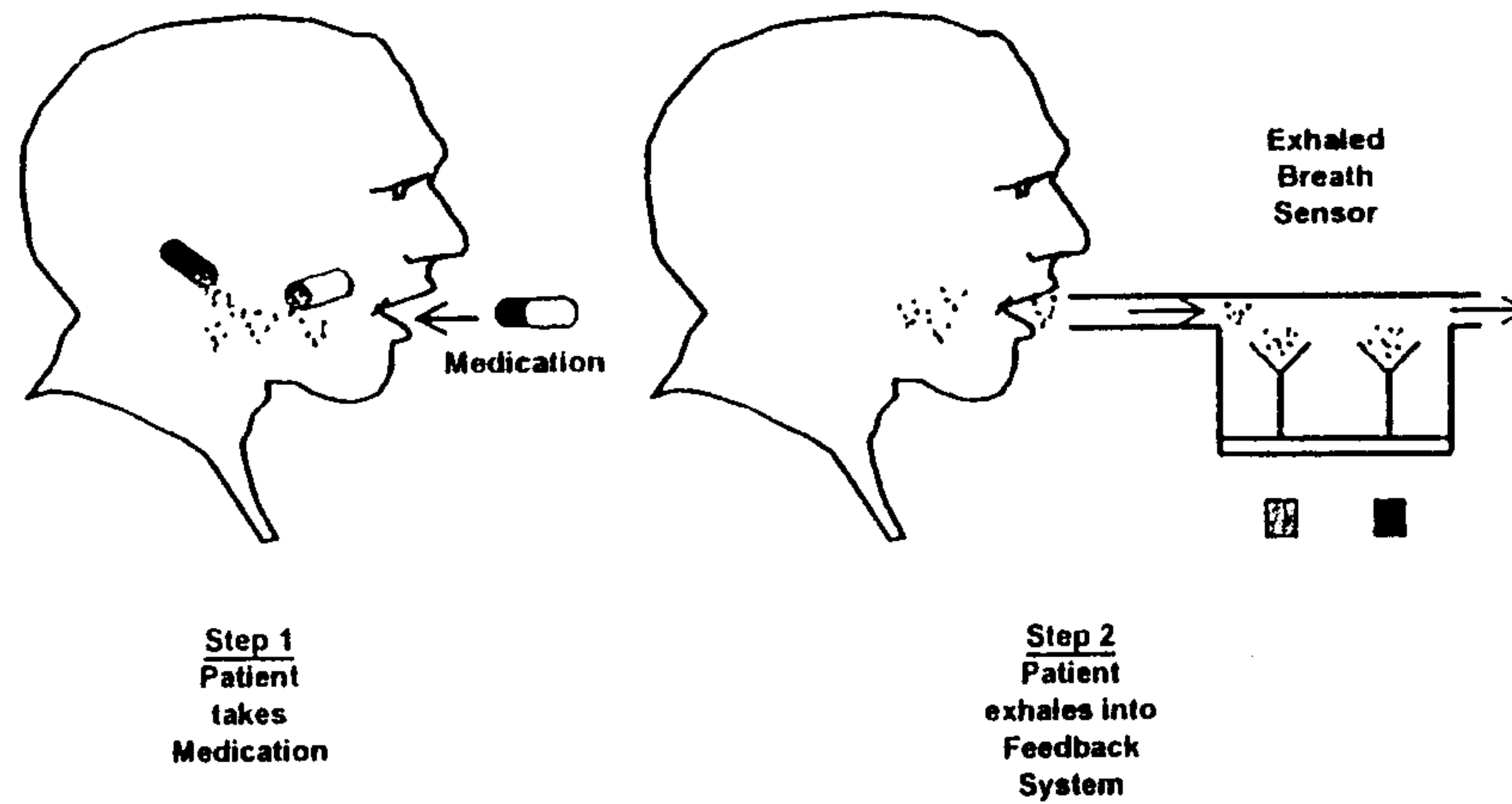

FIG. 1

Patient Compliance Monitoring System Overview



PCMS includes marker compound included in medication that is exhaled into detection system for accurate and reliable monitoring off-site

FIG. 2

Patient Compliance Monitoring System Step 1 - Medication is taken, releasing Marker Compound

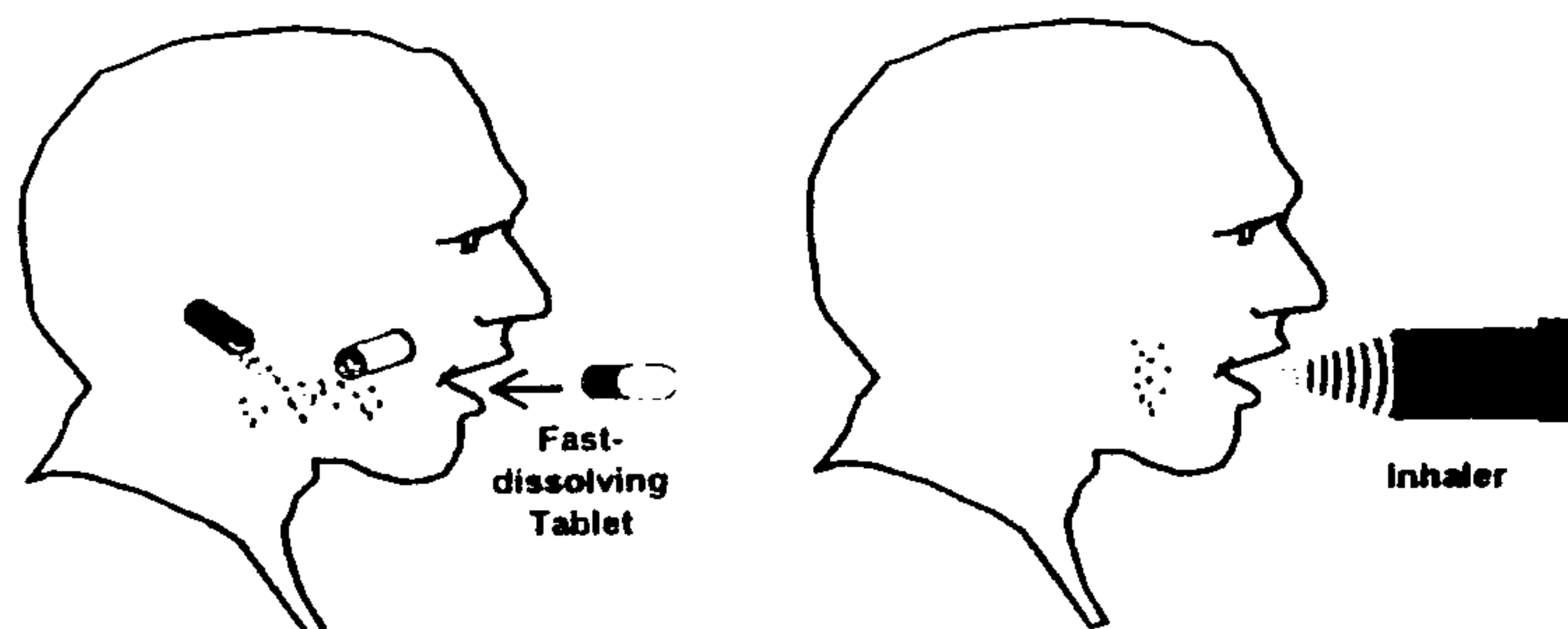

Marker compound is released by dosage form for detection

FIG. 3

**Patient Compliance Monitoring System
Step 2 - Marker Detection System**

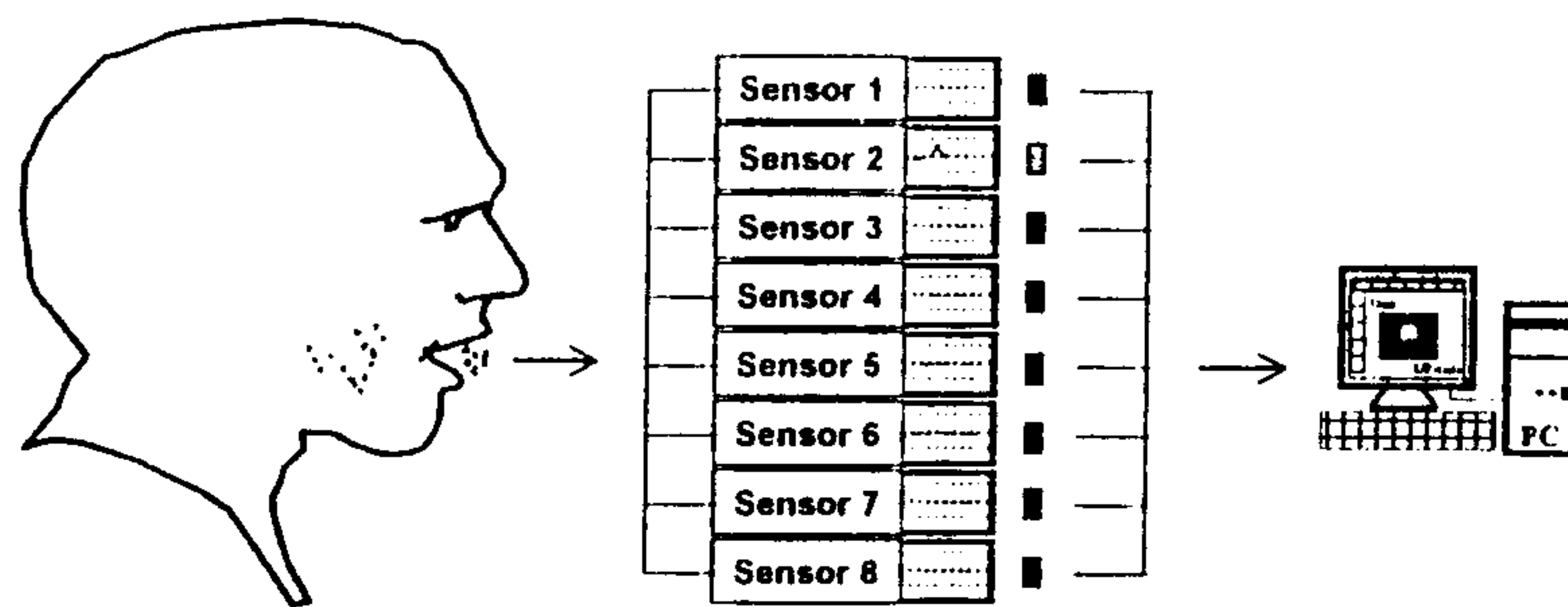

PCMS includes marker compound included in medication that is exhaled into detection system for accurate and reliable monitoring off-site

FIG. 4

