

(No Model.)

2 Sheets—Sheet 1.

A. HEMSLEY.  
PHOTOGRAPH FLASH LAMP.

No. 525,899.

Patented Sept. 11, 1894.

Fig. 1

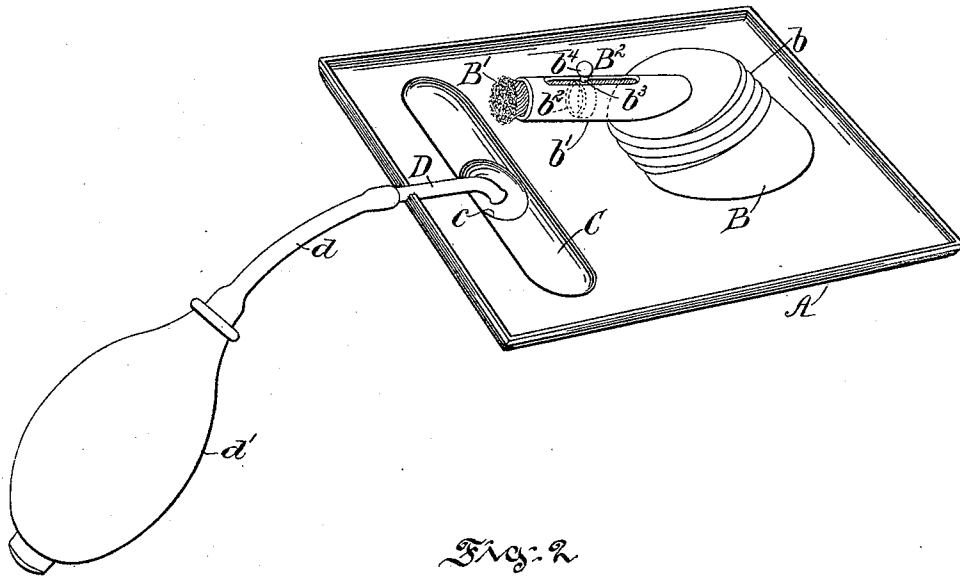
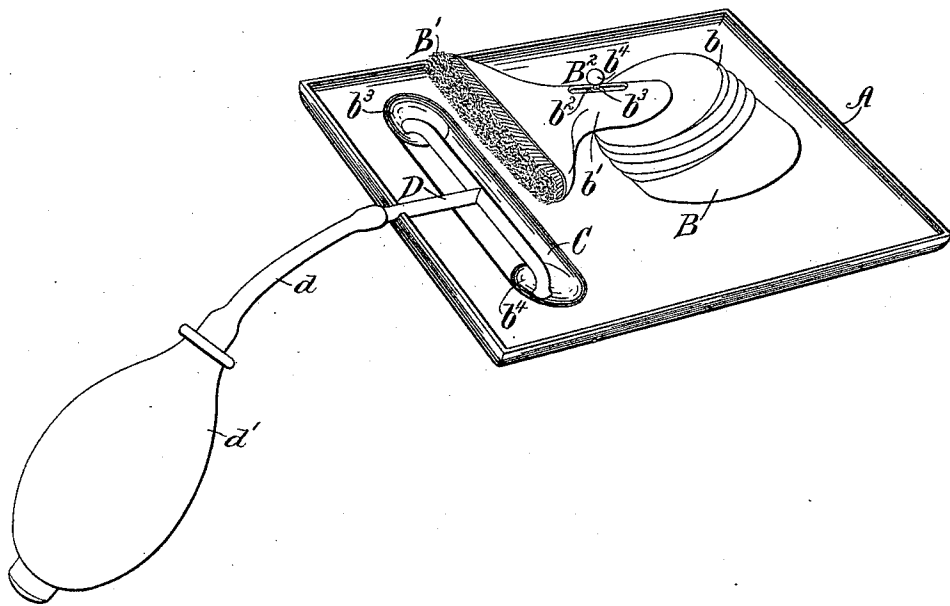

Fig. 2



Witnesses:  
Thomas M. Smith.  
Richard C. Maxwell.

Inventor:  
Alexander Hemsley,  
By Walter Douglas  
Attorneys.

(No Model.)

2 Sheets—Sheet 2.

A. HEMSLEY.  
PHOTOGRAPH FLASH LAMP.

No. 525,899.

Patented Sept. 11, 1894.

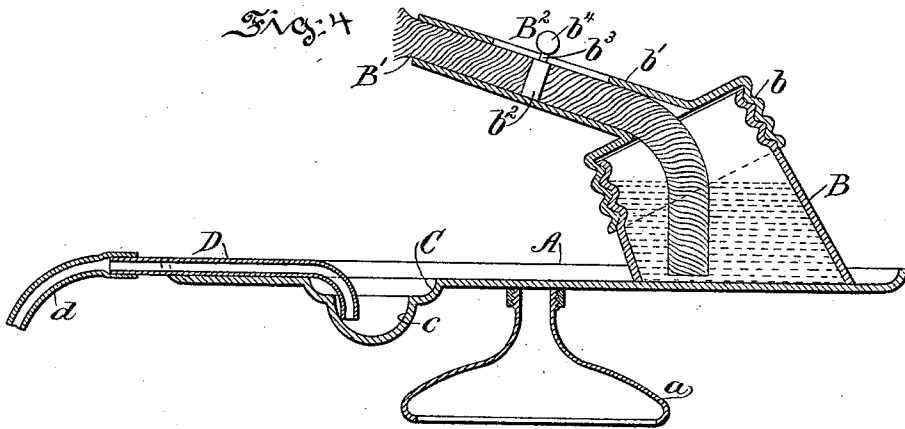
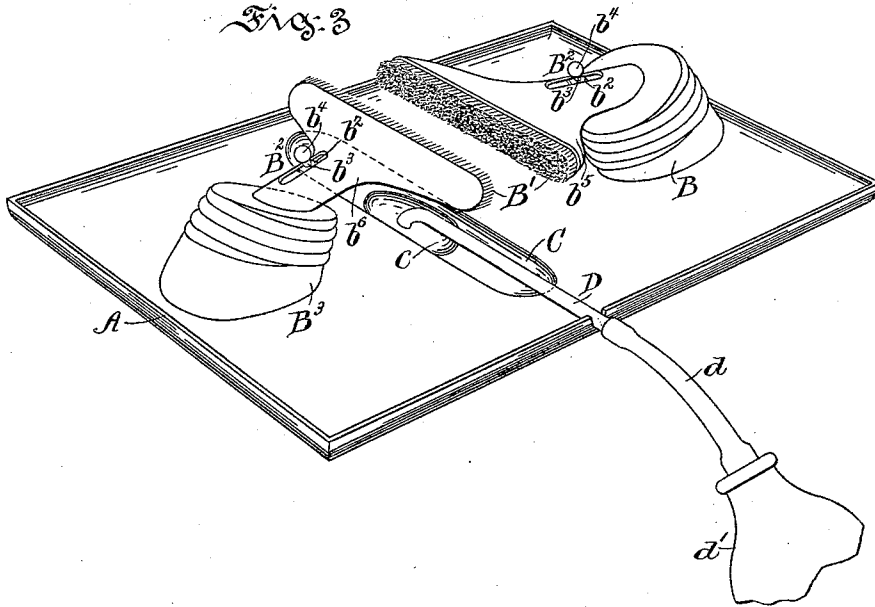

Witnesses:  
Thomas M. Smith.  
Richard C. Maxwell.

Inventor.  
Alexander Hemsley,  
By J. Walter Douglas  
Attorneys.

# UNITED STATES PATENT OFFICE.

ALEXANDER HEMSLEY, OF PHILADELPHIA, PENNSYLVANIA.

## PHOTOGRAPH FLASH-LAMP.

SPECIFICATION forming part of Letters Patent No. 525,899, dated September 11, 1894.

Application filed March 30, 1894. Serial No. 505,680. (No model.)

To all whom it may concern:

Be it known that I, ALEXANDER HEMSLEY, a citizen of the United States, residing at the city of Philadelphia, in the county of Philadelphia and State of Pennsylvania, have invented certain new and useful Improvements in Photographic Flash-Lamps, of which the following is a specification.

My invention has relation to a lamp for flashing powder or the like; and it relates more particularly to the construction and arrangement of a lamp for such purpose.

The principal object of my invention is to provide a simple, inexpensive, durable and effective lamp adapted to permit of the flashing of powdered magnesium and other somewhat similar materials or compounds for the production of a momentary intense sunlight or incandescent flame for instantaneous photographic work.

My invention consists of a photographic flash lamp constructed and arranged in substantially the manner hereinafter described and claimed.

The nature and scope of my invention will be more fully understood from the following description taken in connection with the accompanying drawings forming part hereof, and in which—

Figure 1, is a perspective view of a flash lamp embodying features of my invention. Fig. 2, is a similar view of a slightly modified form of such a lamp adapted for the ignition of powdered magnesium or other compound for producing an intense flame. Fig. 3, is a perspective view of a still further modified form of lamp embodying features of my invention adapted especially for the flashing of powdered magnesium or similar material and provided with two fluid wick containers and a powder-trough interposed between them and having an air pipe provided with a bulb for presenting the said material to the flames of said wicks; and Fig. 4, is a central longitudinal section through the flash lamp of Fig. 1, supported from a standard and showing the detail construction and arrangement thereof.

Referring to the drawings A, is a base adapted to be supported from a standard  $a$ , as shown in Fig. 4, or of any other preferred construction.

B, is an oil or fluid container secured to the base A, and provided with a removable threaded nozzle  $b$ , having an inclined slotted wick tube  $b'$ , a wick  $B'$ , and a regulating device  $B^2$ , therefor consisting of a ring  $b^2$ , surrounding the wick and provided with a stem  $b^3$ , having a knob  $b^4$ .

C, is an oblong trough located adjacent to the container B, and either formed in the base A, or supported therefrom in any preferred manner, for example, by means of a support secured into the base A. This trough as shown in Figs. 1 and 3, may be provided with a central depression or recess  $c$ , and engaging therein is a curved air pipe D, extending beyond the base plate A, and to which is detachably applied a flexible tube  $d$ , having a bulb  $d'$ , which latter is adapted by pressure exerted thereon to force a blast of air through the tube  $d$ , and pipe D, to and under powder supplied to the trough C, for lifting the same into the presence of the wick flame, producing thereby a momentary intense light or flash for taking an instantaneous photograph and in such manner as that the details in the negative will be clearly and fully brought out therein.

The lamp of Fig. 2 differs from that of Fig. 1 in the construction and arrangement of the oblong trough C, for the reception of the flashing powder and the air pipe leading thereto and connected therewith. In this instance the trough is provided in the bottom with end depressions or recesses  $b^3$  and  $b^4$ , and the air admission pipe D, is arranged in the form of a T extending downward toward the bottom of said depressions or recesses  $b^3$  and  $b^4$  so that in the forcing of a blast of air through said pipe D, by means of the tube  $d$ , and the bulb  $d'$ , attached thereto, it will divide in the middle in two directions and pass toward the respective recesses  $b^3$  and  $b^4$ , and the powder of the trough will be lifted therefrom in a more or less dense cloud and of considerable area into the presence of the flame at the exposed end of the wick  $B'$ , for effecting the quick and complete ignition thereof, and for producing a flame of great intensity for insuring characteristic sharpness of detail in the negative exposed to the influence of such a light or flash produced in the manner herebefore explained.

In Fig. 3, the lamp is provided with two oil or fluid containers B and B<sup>3</sup>, with projecting slotted wick tubes b<sup>5</sup> and b<sup>6</sup>, and wick regulating devices B<sup>2</sup>, connected therewith and an oblong trough C, for containing powder, such as magnesium or other suitable ignitable compound interposed between said containers, in order to permit of a flame being produced in the presence of the lighted wicks B', of great intensity or high momentary incandescence. In this instance the air admission pipe D, is connected with the interior of the interposed trough C, and extends beyond the same and the base A, as shown, in order to permit of the attachment thereto of a rubber tube d, with a bulb d', as illustrated. The base A, may be mounted on an adjustable support or standard such as shown in Fig. 4, if desirable for increasing the efficiency of the lamp in use.

It will be manifestly obvious that as to minor details of construction, as well as arrangement of parts of the lamp illustrated and hereinbefore explained still further modifications may be made without departing from the spirit of my invention.

Having thus described the nature and objects of my invention, what I claim as new, and desire to secure by Letters Patent, is—

1. A flash lamp, comprising a base having an oblong recessed powder trough in one portion, a pipe extending downward into said

trough, means connected with said pipe for forcing air therethrough, a fluid container located in the other portion of said base and at an angle thereto and provided with a slotted wick-tube having a detachable nozzle in engagement with said container, a wick adjustable in the slotted portion of said tube set at such an angle to said container as to occupy a position above said trough so as to permit of powder therefrom being lifted by said air forcing means into a flame of said wick, substantially as and for the purposes set forth.

2. A flash lamp, comprising a base provided with a powder trough, a pipe leading into the same and having means connected therewith for forcing air therethrough, fluid containers provided with regulating wick tubes connected with threaded detachable nozzles of said containers, and the said tubes located above said trough in such manner as that powder therefrom is adapted to be lifted by the air into the presence of the wick flames, substantially as and for the purposes set forth.

In testimony whereof I have hereunto set my signature in the presence of two subscribing witnesses.

ALEXANDER HEMSLEY.

Witnesses:

THOMAS M. SMITH,  
RICHARD C. MAXWELL.