

(19) **DANMARK**

(10) **DK/EP 2853512 T3**



(12) **Oversættelse af  
europæisk patentskrift**

Patent- og  
Varemærkestyrelsen

- 
- (51) Int.Cl.: **B 66 C 1/16 (2006.01)** **B 66 C 1/64 (2006.01)**
- (45) Oversættelsen bekendtgjort den: **2016-09-05**
- (80) Dato for Den Europæiske Patentmyndigheds bekendtgørelse om meddelelse af patentet: **2016-07-13**
- (86) Europæisk ansøgning nr.: **14185937.1**
- (86) Europæisk indleveringsdag: **2014-09-23**
- (87) Den europæiske ansøgnings publiceringsdag: **2015-04-01**
- (30) Prioritet: **2013-09-26 NO 20131289**
- (84) Designerede stater: **AL AT BE BG CH CY CZ DE DK EE ES FI FR GB GR HR HU IE IS IT LI LT LU LV MC MK MT NL NO PL PT RO RS SE SI SK SM TR**
- (73) Patenthaver: **AF Offshore Decom AS, P.O. Box 6272 Etterstad, 0603 Oslo, Norge**
- (72) Opfinder: **Hanes, Eirik, Molstadvn 11, 1480 SLATTUM, Norge**
- (74) Fuldmægtig i Danmark: **Inspicos P/S, Kogle Alle 2, 2970 Hørsholm, Danmark**
- (54) Benævnelse: **Indretning til at forbinde et løfteorgan, såsom en kran, til et objekt, som skal løftes**
- (56) Fremdragne publikationer:  
**WO-A1-2008/022368**  
**JP-A- 2002 362 878**  
**JP-U- H 072 377**  
**JP-U- H0 444 274**  
**JP-U- H0 549 780**  
**JP-U- S5 447 770**  
**US-A- 2 721 756**  
**US-A- 3 276 808**  
**US-A- 3 519 302**  
**US-A- 5 735 561**



## **DESCRIPTION**

**[0001]** The present invention relates to a device to connect a lifting appliance, such as a crane, to an object that shall be lifted. The device is especially suited for use together with lifting tools in the form of extended bodies of textile material, rope or wire, which is formed with hoops or hooks in at least one end, or as endless grommets. Such lifting tools are often used when one wants to lift objects that are not fitted with lifting lugs for a crane hook and are used to form the connection between the crane hook and the lifting lug. A hoop can comprise one or more straps, each of which stretches from one place on the object to the crane hook, or possibly to the crane hook via a spreader beam.

**[0002]** When large objects with partly irregular shapes, such as, for example, part of an offshore structure that shall be moved, it is not always possible to fasten the hoop directly onto the structure part. The structure part often weighs several tens of tonnes and sometimes several hundred tonnes. The structure part has sharp edges and a hoop can therefore be damaged during the lift. Therefore, it is common to weld or securely bolt lifting lugs or other types of lifting points to the structure part. However, for such heavy lifts the lugs welded on the structure must be certified before the lift can start. The certification regulations are very strict for the offshore industry. Both the welding and the certification of this take a long time and the whole decommissioning of, for example, a platform will therefore take considerably longer time than if one could fasten the hoop directly to the structure part. Furthermore, one is dependent on the basis material in the structure that shall be lifted being of sufficient good quality, for example, that the material has no internal weaknesses, such as rifts, which can lead to a lug welded on being ripped off.

**[0003]** One can envisage the use of a hook or other L-formed device to form the connection, but these do not provide a safe grip as they could easily come lose if the object should make contact with something during the lift. They will also lead to an unfavourable load of the structure that shall be lifted with potential askew loads and local force concentrations that can reduce the capacity of the structure. From WO 2008/022368 is known a solution where two L-shaped devices grip a beam; one from each side.

**[0004]** From US 5863085 is known a tubular shaped lifting block that is adapted to receive an end of a tube to be lifted. The use of this requires that there is actually a tube end on the structure that can receive the lifting block. Moreover, it is a high risk that the tubular lifting block can slide off the tube end, even if the structure is tilted only slightly.

**[0005]** A lifting block is known from US 4092038 that is adapted to encircle a tubular element on the structure to be lifted. Although, it is relatively easy to mount it can easily slide along the tubular element and the structure may therefore suddenly tilt viciously. This tilting may be fatal both to equipment and persons in the vicinity. To avoid this sliding, stop means are arranged adjacent the lifting block. The stop means have to be welded to the structure. This welding may weaken the structure and has to be controlled and certified. The lifting block must also be adapted closely in diameter to the tubular element that it is placed around.

**[0006]** JPH0444274U shows a lifting device for a pallet. Inclined notches are formed on the underside of the pallet, into which a tube can be positioned. Lifting straps can be attached to each end of the tubes.

**[0007]** This device is only capable of lifting pallets that have been prepared with the inclined notches. The lifting must be done with the pallet in a completely horizontal position. If the centre of gravity of the load is outside the centre of the pallet, the pallet may become skewed and there is a great risk that the pallet will slide relative to the tubes. The result may be that the lifting straps slide off the tubes and the load falls down.

**[0008]** Consequently, this lifting device is not suitable for lifting objects with a centre of gravity away from the volumetric centre of the object or where the centre of gravity is unknown.

**[0009]** US 3276808 shows a similar lifting device as JPH0444274U. Also here notches have been formed at the underside of the pallet. This device has substantially the same disadvantages as JPH0444274U.

**[0010]** US 2721756 shows another lifting device similar to JPH0444274U and US 3276808. This has substantially the same disadvantages as the above prior art.

**[0011]** US 3519302 shows yet another lifting device for lifting pallets, which also have substantially the same drawbacks as JPH0444274U, US 3276808 and US 2721756.

**[0012]** JP2002362878 shows a lifting device for lifting the undercarriage of a belt driven vehicle. The device is specially formed

to fit against the underside of the undercarriage. The device is not suitable for lifting other objects, such as portions of frameworks in the offshore industry.

**[0013]** Thus, there are today no known devices that make it easy to connect a hoop with such a heavy structure part in a simple and safe way. Therefore, the invention has the aim of providing a device that makes it possible to connect a lifting tool with a large object in a safe and easy way. This is achieved by the features that are given in the subsequent claim 1.

**[0014]** The lifting device is fitted quickly and simply and the time it takes, for example, to decommission an offshore structure is thereby considerably reduced. This also reduces the costs. The lifting forces are transferred as pressure forces only in the structure that is lifted. Thereby, any weaknesses in the structure material have less significance.

**[0015]** It is preferred that the lifting device according to the invention has a contact surface against the structure which is large enough so that the lifting forces do not lead to essential, permanent, i.e. plastic, deformations in the lifting device.

**[0016]** In a first embodiment the main part is fitted at both ends with a trunnion-formed end comprising a groove with a generally circular cross section and an externally arranged thickening, as the groove is able to receive a hoop or a loop on a wire, and the thickening prevents the hoop or the wire from sliding out from the groove. Thereby, the device can easily be connected with a hoop or a wire.

**[0017]** In one embodiment, the guiding parts have features for anchoring of a temporary fastening element to hold the device in place until the lifting forces are established. Thereby, the device can temporarily hang on to the object that shall be lifted until the lifting forces are connected and the lift has begun.

**[0018]** In a further embodiment the guiding parts are set up to reach over the beam or the strut, which the main part is placed on the underside of, and the guiding parts are fitted at their upper ends with fastening means for a hoop or other extended body. Thereby, a device is provided which is very simple in its construction and consists of relatively few parts.

**[0019]** It is advantageous that the fastening means comprises a hole through each of the guiding parts and a peg that is arranged to be led through the holes. Thus, a shackle can easily be connected to the device.

**[0020]** In an alternative embodiment, the contact surface is formed by a plate that is located between the guiding parts. Thereby, a good contact surface is ensured against the object that shall be lifted. This gives a good distribution of forces.

**[0021]** In a further variant at least one support plate is connected at a right angle with the plate that forms the contact surface. This support plate transfers forces to the main part. Thereby, a good shoring up of the plate that makes up the contact surface and a good force transfer to the main part is ensured. Then, the plate that makes up the contact surface can advantageously have smaller dimensions.

**[0022]** In another embodiment, at least a part of the first contact surface comprises an end edge on a support plate that is arranged transverse to the main part. This leads to a simple construction at the same time as the forces are transferred in a secure way.

**[0023]** As the device substantially comprises steel plates that are welded together and possibly a steel tube that forms the trunk of the main part, a device is provided that is both simple to produce and simple in its structure.

**[0024]** The invention shall now be explained in more detail with reference to the enclosed figures, in which:

Figure 1 shows a large structure part that is lifted with the help of a device according to the invention.

Figure 1a shows a detail of figure 1 and a device according to the invention.

Figure 2 shows a first embodiment of a lifting device according to the invention in detail.

Figure 3 shows a second embodiment of a lifting device according to the invention in detail.

Figure 4 shows a third embodiment of a lifting device according to the invention in detail.

Figure 5 shows a fourth embodiment of a lifting device according to the invention in use, and

Figures 6a and 6b show the fourth embodiment in more detail.

**[0025]** Figure 1 shows a structure part 1 which is a part of a larger offshore structure that is about to be decommissioned. The structure part 1 hangs in a crane (not shown) via a crane hook 2 that can be placed on a crane vessel (not shown). A system of hoops 3 extends from the crane hook 2. These couple the crane hook 2 via a spreader beam 17 and hooks 4 to a device 5 according to the invention, which in the following will be called a lifting block, which together is set to lift the structure part 1.

**[0026]** Figure 1a shows a detail of figure 1 around the lifting device 5. The lifting device 5 is arranged under an I-beam 26 in the structure part 1 and lies in a corner formed by the I-beam 26 and a strut 27. The strut 27 also has an I-beam form. The I-beam 26 has a flat underside against the lifting device 5 and the strut 27 also has a flat side against the lifting device 5.

**[0027]** It is clear that the lifting block 5 can be formed to lie against other types of beams than I-beams and also against struts with a round or oval cross section.

**[0028]** The lifting block 5 according to the invention stretches underneath the whole of the I-beam 26 and has, on either side, a trunnion-like projection 28 to receive a loop 30 at the end of a hoop.

**[0029]** Figure 2 shows the lifting block 5 according to the invention in more detail in a first embodiment. The projection 28 has a disc 29 outermost and inside this there is a cylindrical section 31, which the loop 30 of the hoop 3 is set up to rest against. Inside the cylindrical section 31, guiding plates 32 are arranged on each side. The guiding plates 32 are set up to be placed on the outside of the I-beam 26 and prevent the lifting block 32 from gliding sidewise with respect to this.

**[0030]** A contact surface 33 is arranged between the guiding plates 32. This is set up to lie against the underside of the I-beam 26.

**[0031]** The cylindrical section 31 is extended inside the guiding plates 32 and forms a continuous cylinder 34. A support plate 35 is arranged in parallel with and in the middle of the guiding plates 32. The edge 36 of the support plate 35 is set up to lie against the strut 27. Thereby, the lifting block transfers the lifting forces into the I-beam 26 and the strut 27.

**[0032]** The guiding plates 32 are fitted with a number of holes 37 that are used to fasten temporarily the lifting block 5 to the I-beam 26 until the hoops are subjected to tension and the lifting block is held in place by the hoops alone. The temporary fastening to the I-beam can be made by threading bolts or pins through the holes 37 so that the lifting block 5 is hanging in the flange 38 of the I-beam 26 (see figure 1 a). Instead of holes, protrusions can also be arranged for the fastening of the straps. However, other ways to arrange a temporary fastening for the lifting block can also be imagined.

**[0033]** It is preferred that the lifting block 5 is constructed by welding together a pipe 34 with the different plates 28, 32, 33 and 35. It can be made in different sizes adjusted to the different dimensions used for the I-beams 26. The lifting block 5 must be certified for offshore lifts, but this certification can be made in good time before use and it can be made on land.

**[0034]** When the hoops are subjected to tension in that the crane hook 2 is pulled up, the hoops will force the lifting block 5 in toward the I-beam 26 and the strut 27, at the same time as the lifting block 5 will automatically glide into a correct position on the temporary suspension 37 between the beam 26 and the strut 27 as shown in figure 1 a. The pipe 34 has a dimension, which will tolerate with a good margin the forces to which it is subjected. As long as the hoop is taut (even with relatively limited tension), it will stay within the plate 28. The plate 28 is dimensioned so that the loop 30 must be opened relatively widely so that it is possible to thread it over the plate 28. The lift can therefore be carried out with the assurance that the loop 30 will not jump off the lifting block 5. The lifting block will transfer a part of the horizontal lifting forces into the lower flange of the beam 26 in the junction between the beam 26 and the strut 27.

**[0035]** Figure 3 shows a second embodiment of the lifting block according to the invention. It is substantially similar to the embodiment in figure 2 apart from the guiding plates 32 being rotated with respect to the contact plate 33, so that the upper edge 39 (upper in the sense of uppermost in the figure) forms an angle with the contact plate 33. This rotated position ensures that the guiding plate 32 will extend outside both the I-beams in the structure that form the corner against which the lifting device shall lie. This embodiment is particularly favourable if the corner is made by two beams of the same width. The holes 37 are placed so that it is possible temporarily to fasten the lifting block 5 to the flanges on both the adjoining I-beams.

**[0036]** Figure 4 shows a third embodiment of the lifting block 5, where the guiding plates 32 are extended with respect to the embodiment in figure 2, so that they extend along a greater length of the I-beam. An arched plate 40 is arranged at the extended end of the guiding plates 32. This is set up to lie against a round strut on the structure that shall be lifted. The curvature of the

plate 40 must be adapted to the different diameters on the round strut on the structure. Therefore, lifting blocks of different dimensions must be produced.

[0037] Figure 5 shows a fourth embodiment of the lifting block 5 according to the invention. Here, the guiding plates 32 are extended so that they stretch over the I-beam 26. The guiding plates 32 that also function as lifting plates are fitted at the upper end with holes 41 and a peg 42 that stretches between the holes 41. A lifting shackle 43 is fastened to the peg 42. A hoop is in turn fastened to the lifting shackle 43.

[0038] The lifting block 5 in figure 5 is shown in more detail in the figures 6a and 6b. Figure 6a shows the lifting block seen in perspective from above. Figure 6b shows the lifting block 5 seen in perspective from below. From above and below means in this context in relation to the orientation that the lifting block has when in use. The lifting block 5 comprises a pipe part 44 that extends between the two guiding and lifting plates 32. A contact plate 33 also runs between the guiding and lifting plates 32. A support plate 35 that has a contact edge 36 is placed halfway between, and in parallel with, the guiding and lifting plates 32. A pair of stiffening plates 45 is arranged between the pipe part 44 and the contact plate 33. Both of these run between the guiding and lifting plates 32. The holes 41 in the upper end of the guiding and lifting plates 32 are also visible.

[0039] Furthermore, the guiding and lifting plates 32 are fitted with holes 37 that can be used to fasten the lifting device temporarily to the I-beams 26 in the same way as for the earlier embodiment.

[0040] In the case shown in figure 5, the lifting device shall be placed in a corner between the beam 26 and the strut 27 that form an angle of about 45°. Thus, the contact edge 36 of the support plate 35 and the contact plate 33 form a corresponding angle so that they make good contact against both the I-beam 26 and the strut 27 in the corner. This is ensured by tightening the lifting tool 3 by lifting the crane hook 2. The lifting block 5 thereby automatically will be pulled into a correct position with the help of the guiding and lifting plates 32. The lifting plate 33 will transfer parts of the horizontal lifting forces in the lower flange of the beam 26 in the cross between the beam 26 and the strut 27.

[0041] When the lifting block is placed in the corner between the I-beam 26 and the strut 27, the peg 42 is threaded through the hole 41 in one of the guiding and lifting plates 32, through the ears of the shackle 43 (the shackle 43 is threaded through the loop 30 of the hoop in advance) and further through the hole 41 in the other guiding and lifting plate 32. Thereafter, the peg 42 is secured in a way that is well known for lifting shackles.

[0042] In this embodiment, the hoops will be in safe engagement with the lifting blocks without having to be taut.

[0043] Instead of the guiding parts also functioning as anchoring points for hoops, it is also possible to use separate lifting plates that are formed with a hole in the lower end so that they can be threaded onto the trunnion-formed protrusions, such as shown in, for example, figure 2.

## REFERENCES CITED IN THE DESCRIPTION

This list of references cited by the applicant is for the reader's convenience only. It does not form part of the European patent document. Even though great care has been taken in compiling the references, errors or omissions cannot be excluded and the EPO disclaims all liability in this regard.

### Patent documents cited in the description

- [WO2008022366A \[0003\]](#)
- [US5863085A \[0004\]](#)
- [US4092038A \[0005\]](#)
- [US3276808A \[0009\] \[0010\] \[0011\]](#)
- [US2721756A \[0010\] \[0011\]](#)
- [US3519302A \[0011\]](#)
- [JP2002362879E \[0012\]](#)

## PATENTKRAV

1. Indretning til at forbinde et løfteudstyr til et objekt, som skal løftes, idet indretningen (5) omfatter en hoveddel, hvilken hoveddel har en første kontaktoverflade (33), som er komplementær til et første langsgående element (26) af objektet (1), som skal løftes, når hoveddelen strækker sig i det væsentlige tværgående i forhold til det første langsgående element (26), kendetegnet ved, at hoveddelen har en anden kontaktoverflade (36), som er komplementær til et andet element (27) på objektet (1), som skal løftes, hvilke kontaktoverflader (33, 36) danner en fast vinkel i forhold til hinanden, hvilken vinkel svarer til vinklen imellem det første og det andet element (26, 27), hvilken hoveddel er indrettet til at optage vægten af objektet via den første og den anden kontaktoverflade (33, 36), og at hver ende (29, 31) af hoveddelen er forsynet med forbindelsesfunktioner til et løfteværktøj, og at indretningen yderligere omfatter et par af styringsdele (32), som er anbragt vinkelret på hoveddelen, idet styringsdelene (32) er anbragt med en indbyrdes afstand, som er en smule større end bredden af det første element (26).
2. Indretning ifølge krav 1, kendetegnet ved, at udstrækningerne af kontaktoverfladerne (33, 36) er tilpasset til vægten af objektet (1), som skal løftes, således at permanente deformationer i det væsentlige undgås.
3. Indretning ifølge krav 1 eller 2, kendetegnet ved, at forbindelsesfunktionerne er tapformede endeelementer (29, 31), som omfatter en rille (31) med et generelt cirkulært tværsnit og en ydre fortykkelse (29), og således at rillen (31) er i stand til at modtage en ring eller en løkke på en wire og fortykkelsen (29) forhindrer ringen eller wiren i at glide ud af rillen (31).
4. Indretning ifølge et hvilket som helst af de foregående krav, kendetegnet ved, at styringsdelene (32) har funktioner (37) til forankring af et midlertidigt fastgørelseselement til at holde indretningen på plads indtil løftekræfterne påføres til den.
5. Indretning ifølge et hvilket som helst af de foregående krav, kendetegnet ved, at styringsdelene (32) har en længde, der rækker over det første element (26) til den modstående side af det første element fra den første kontaktoverflade (33), og at styringsdelene (32) er udstyret med fastgørelsesorganer (41, 42, 43) til en ring (30) eller løftewire, ved deres øvre ender.
6. Indretning ifølge krav 5, kendetegnet ved, at fastgørelsesorganerne omfatter et hul (41) i hver af styringsdelene (32) og en dyvel (42), som passer igennem hullerne (41).
7. Indretning ifølge et hvilket som helst af de foregående krav, kendetegnet ved, at kontaktoverfladen (33) er dannet af en plade, som er placeret imellem styringsdelene (32).

8. Indretning ifølge krav 7, kendetegnet ved, at i det mindste én støtteplade (35) er forbundet i en ret vinkel til pladen, som danner den første kontaktoverflade (33).

9. Indretning ifølge et hvilket som helst af de foregående krav, kendetegnet ved, at i det mindste en del af den første kontaktoverflade (36) omfatter en endekant på en støtteplade (35), som er anbragt tværgående i forhold til hoveddelen.

10. Indretning ifølge et af de foregående krav, kendetegnet ved, at den i det væsentlige omfatter stålplader, som er svejset sammen.

11. Indretning ifølge krav 10, kendetegnet ved, at den også omfatter et stålør (34), som danner et skaft af hoveddelen.

DRAWINGS

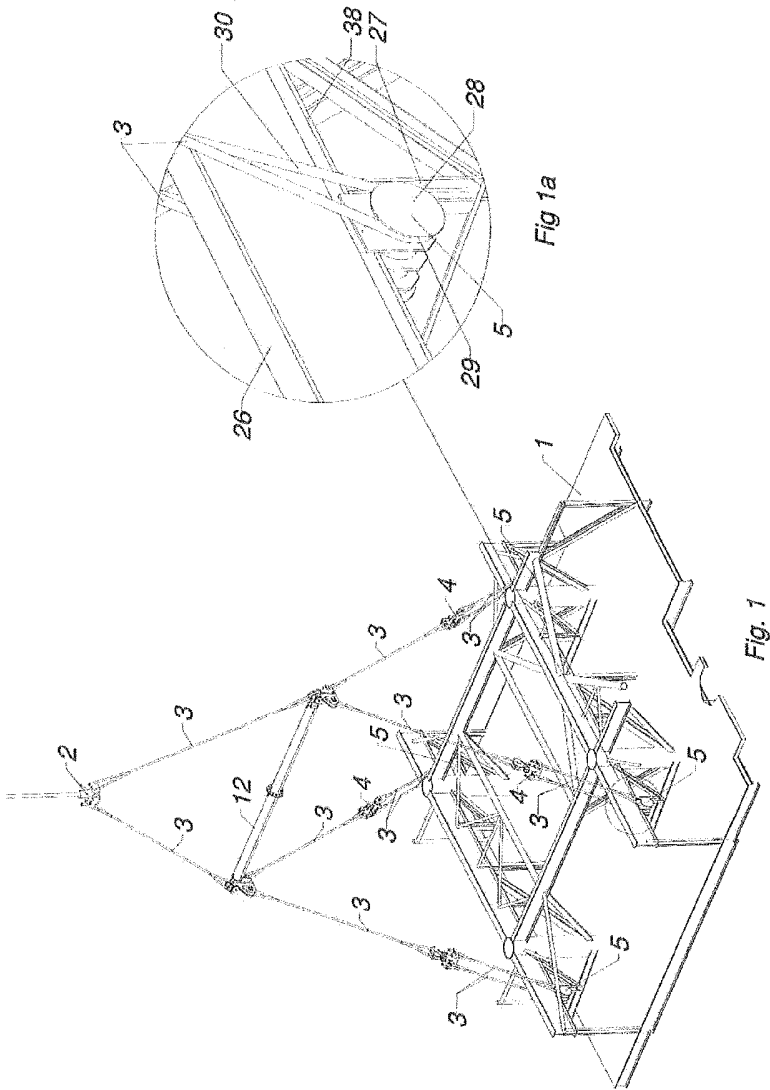

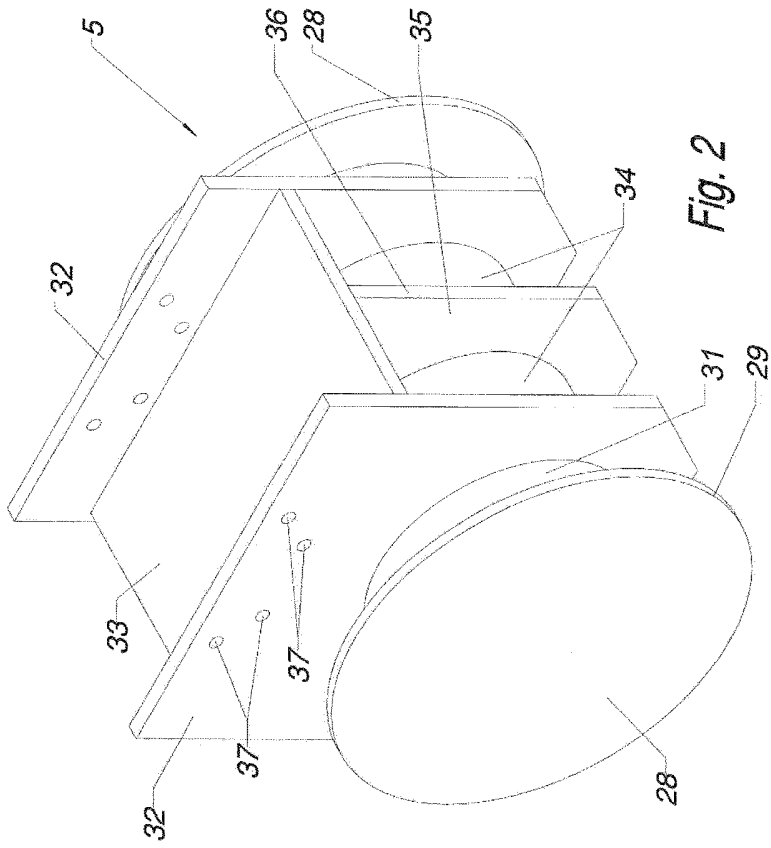

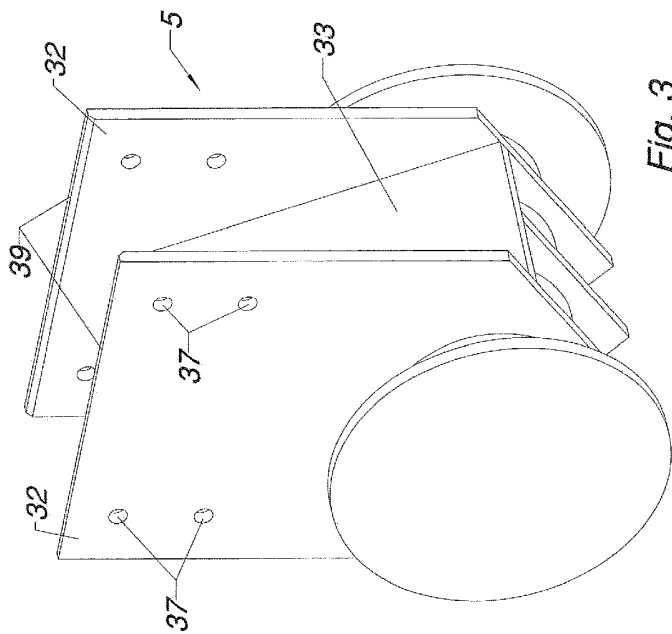

Fig. 3

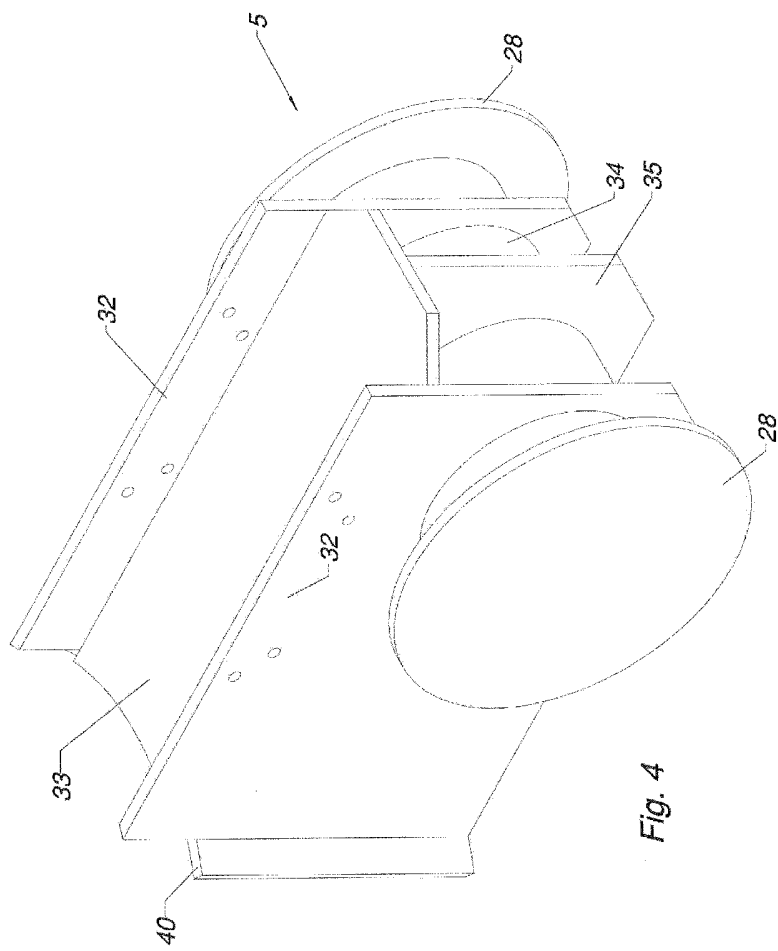
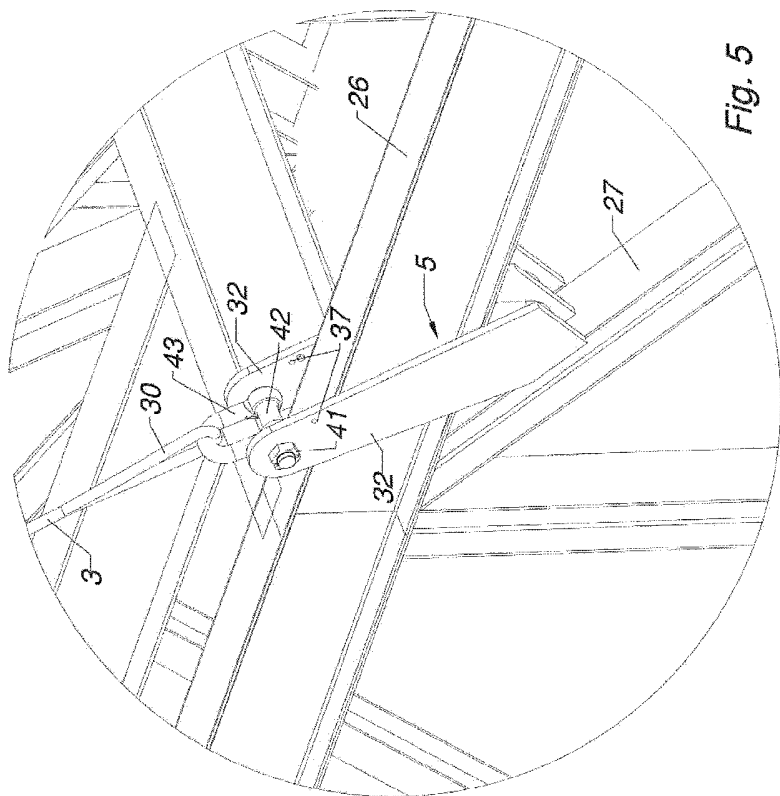

Fig. 4



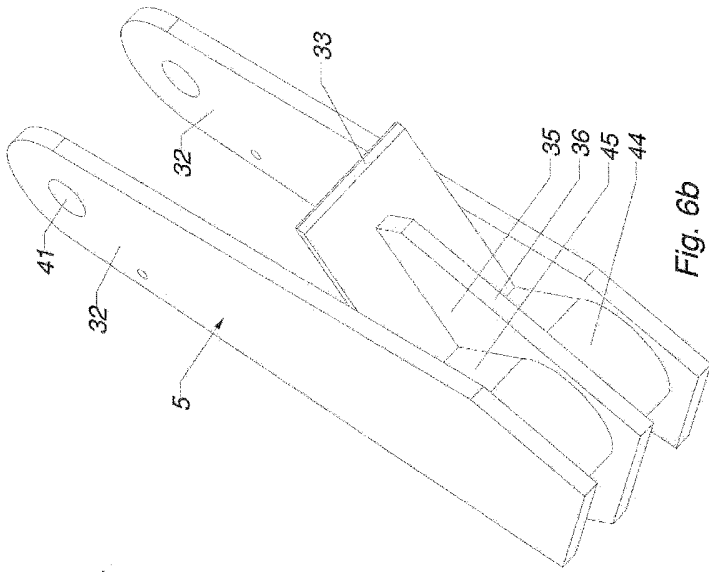

Fig. 6b

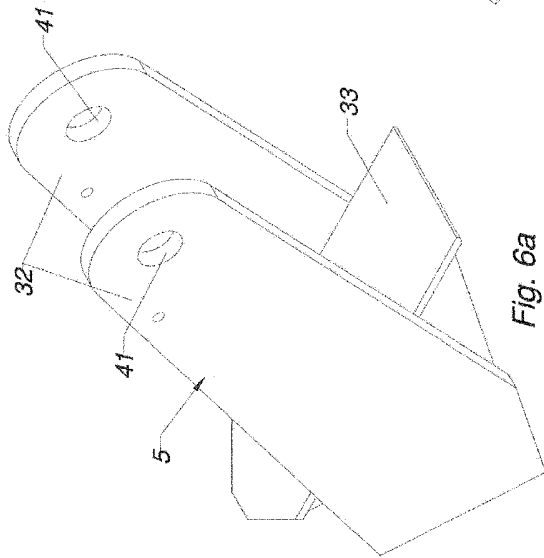

Fig. 6a