

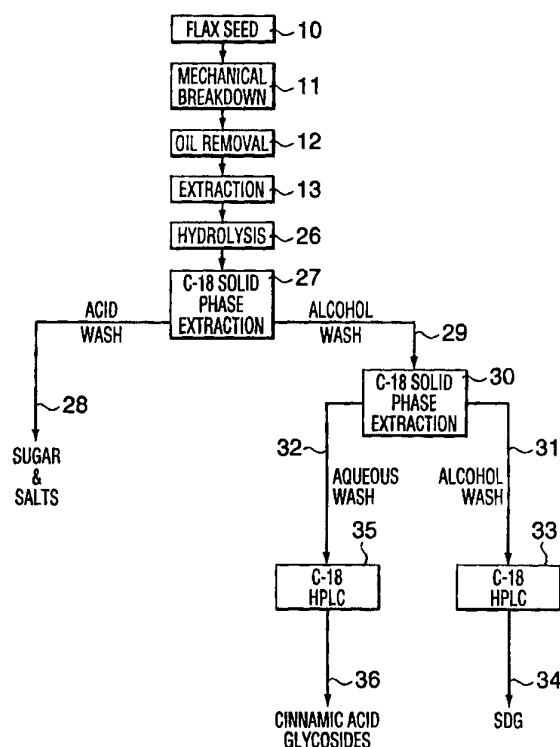

## INTERNATIONAL APPLICATION PUBLISHED UNDER THE PATENT COOPERATION TREATY (PCT)

(51) International Patent Classification <sup>6</sup> : <b>C07H 15/203, C07G 3/00</b>	<b>A3</b>	(11) International Publication Number: <b>WO 96/30468</b> (43) International Publication Date: 3 October 1996 (03.10.96)
<p>(21) International Application Number: PCT/CA96/00192</p> <p>(22) International Filing Date: 29 March 1996 (29.03.96)</p> <p>(30) Priority Data: 08/415,050 31 March 1995 (31.03.95) US</p> <p>(60) Parent Application or Grant (63) Related by Continuation US 415,050 (CIP) Filed on 31 March 1995 (31.03.95)</p> <p>(71) Applicant (for all designated States except US): HER MAJESTY IN RIGHT OF CANADA, represented by THE MINISTER OF AGRICULTURE AND AGRI-FOOD CANADA [CA/CA]; 930 Carling Avenue, Ottawa, Ontario K1A 0C5 (CA).</p> <p>(72) Inventors; and (75) Inventors/Applicants (for US only): WESTCOTT, Neil, D. [CA/CA]; 170 Mount Allison Crescent, Saskatoon, Saskatchewan S7H 4A5 (CA). MUIR, Alister, D. [CA/CA]; 210 Konihowski Road, Saskatoon, Saskatchewan S7S 1B1 (CA).</p>	<p>(74) Agents: EADES, Norris, M. et al.; Kirby, Eades, Gale, Baker, P.O. Box 3432, Station D, Ottawa, Ontario K1P 6N9 (CA).</p> <p>(81) Designated States: AU, CA, CN, HU, JP, KR, PL, US, European patent (AT, BE, CH, DE, DK, ES, FI, FR, GB, GR, IE, IT, LU, MC, NL, PT, SE).</p> <p><b>Published</b> <i>With international search report.</i> <i>Before the expiration of the time limit for amending the claims and to be republished in the event of the receipt of amendments.</i></p> <p>(88) Date of publication of the international search report: 20 February 1997 (20.02.97)</p>	
(54) Title: PROCESS FOR EXTRACTING AND PURIFYING LIGNANS AND CINNAMIC ACID DERIVATIVES FROM FLAXSEED		
(57) Abstract		

A process is described for extracting secoisolariciresinol diglycoside (SDG) and cinnamic acid derivatives from flaxseed which comprises contacting a substantially oil-free flaxseed meal with an aliphatic alcohol solvent, e.g. a mixture of methanol or ethanol with water, to extract phenolics comprising SDG and cinnamic acid derivatives into the alcohol solvent and separating residual solids from the phenolic-rich alcohol solvent. The phenolic-rich alcohol solvent is concentrated by removing solvent therefrom and the phenolic-rich extract obtained is subjected to a base-catalyzed hydrolysis to liberate lignans and cinnamic acid derivatives therefrom in a non-complexed form. Thereafter, the hydrolyzed extract is fractionated into a fraction containing SDG and a fraction containing cinnamic acid derivatives. Either or both of these fractions are then subjected to chromatographic separation to thereby obtain SDG and/or cinnamic acid derivatives at a purity of greater than 95 %.



**FOR THE PURPOSES OF INFORMATION ONLY**

Codes used to identify States party to the PCT on the front pages of pamphlets publishing international applications under the PCT.

<b>AM</b>	Armenia	<b>GB</b>	United Kingdom	<b>MW</b>	Malawi
<b>AT</b>	Austria	<b>GE</b>	Georgia	<b>MX</b>	Mexico
<b>AU</b>	Australia	<b>GN</b>	Guinea	<b>NE</b>	Niger
<b>BB</b>	Barbados	<b>GR</b>	Greece	<b>NL</b>	Netherlands
<b>BE</b>	Belgium	<b>HU</b>	Hungary	<b>NO</b>	Norway
<b>BF</b>	Burkina Faso	<b>IE</b>	Ireland	<b>NZ</b>	New Zealand
<b>BG</b>	Bulgaria	<b>IT</b>	Italy	<b>PL</b>	Poland
<b>BJ</b>	Benin	<b>JP</b>	Japan	<b>PT</b>	Portugal
<b>BR</b>	Brazil	<b>KE</b>	Kenya	<b>RO</b>	Romania
<b>BY</b>	Belarus	<b>KG</b>	Kyrgystan	<b>RU</b>	Russian Federation
<b>CA</b>	Canada	<b>KP</b>	Democratic People's Republic of Korea	<b>SD</b>	Sudan
<b>CF</b>	Central African Republic	<b>KR</b>	Republic of Korea	<b>SE</b>	Sweden
<b>CG</b>	Congo	<b>KZ</b>	Kazakhstan	<b>SG</b>	Singapore
<b>CH</b>	Switzerland	<b>LI</b>	Liechtenstein	<b>SI</b>	Slovenia
<b>CI</b>	Côte d'Ivoire	<b>LK</b>	Sri Lanka	<b>SK</b>	Slovakia
<b>CM</b>	Cameroon	<b>LR</b>	Liberia	<b>SN</b>	Senegal
<b>CN</b>	China	<b>LT</b>	Lithuania	<b>SZ</b>	Swaziland
<b>CS</b>	Czechoslovakia	<b>LU</b>	Luxembourg	<b>TD</b>	Chad
<b>CZ</b>	Czech Republic	<b>LV</b>	Latvia	<b>TG</b>	Togo
<b>DE</b>	Germany	<b>MC</b>	Monaco	<b>TJ</b>	Tajikistan
<b>DK</b>	Denmark	<b>MD</b>	Republic of Moldova	<b>TT</b>	Trinidad and Tobago
<b>EE</b>	Estonia	<b>MG</b>	Madagascar	<b>UA</b>	Ukraine
<b>ES</b>	Spain	<b>ML</b>	Mali	<b>UG</b>	Uganda
<b>FI</b>	Finland	<b>MN</b>	Mongolia	<b>US</b>	United States of America
<b>FR</b>	France	<b>MR</b>	Mauritania	<b>UZ</b>	Uzbekistan
<b>GA</b>	Gabon			<b>VN</b>	Viet Nam

## INTERNATIONAL SEARCH REPORT

International Application No

PCT/CA 96/00192

A. CLASSIFICATION OF SUBJECT MATTER  
IPC 6 C07H15/203 C07G3/00

According to International Patent Classification (IPC) or to both national classification and IPC

## B. FIELDS SEARCHED

Minimum documentation searched (classification system followed by classification symbols)  
IPC 6 C07H C07G C11B

Documentation searched other than minimum documentation to the extent that such documents are included in the fields searched

Electronic data base consulted during the international search (name of data base and, where practical, search terms used)

## C. DOCUMENTS CONSIDERED TO BE RELEVANT

Category *	Citation of document, with indication, where appropriate, of the relevant passages	Relevant to claim No.
A	CHEMICAL ABSTRACTS, vol. 119, no. 3, 19 July 1993 Columbus, Ohio, US; abstract no. 26895, WILSON T.C. ET AL: "Supercritical fluid extraction of polar materials from animal feeds and plant materials" page 762; column 2; XP002021633 see abstract & NATL. MEET. - AM. CHEM. SOC. DIV. ENVIRON. CHEM, vol. 33, no. 1, 1993, pages 391-394, --- -/--	1

Further documents are listed in the continuation of box C.

Patent family members are listed in annex.

## \* Special categories of cited documents :

- "A" document defining the general state of the art which is not considered to be of particular relevance  
 "E" earlier document but published on or after the international filing date  
 "L" document which may throw doubts on priority claim(s) or which is cited to establish the publication date of another citation or other special reason (as specified)  
 "O" document referring to an oral disclosure, use, exhibition or other means  
 "P" document published prior to the international filing date but later than the priority date claimed

- "T" later document published after the international filing date or priority date and not in conflict with the application but cited to understand the principle or theory underlying the invention  
 "X" document of particular relevance; the claimed invention cannot be considered novel or cannot be considered to involve an inventive step when the document is taken alone  
 "Y" document of particular relevance; the claimed invention cannot be considered to involve an inventive step when the document is combined with one or more other such documents, such combination being obvious to a person skilled in the art.  
 "&" document member of the same patent family

Date of the actual completion of the international search

19 December 1996

Date of mailing of the international search report

17. 01. 97

Name and mailing address of the ISA

European Patent Office, P.B. 5818 Patentlaan 2  
NL - 2280 HV Rijswijk  
Tel. (+ 31-70) 340-2040, Tx. 31 651 epo nl,  
Fax: (+ 31-70) 340-3016

Authorized officer

Day, G

## INTERNATIONAL SEARCH REPORT

International Application No

PL/CA 96/00192

C.(Continuation) DOCUMENTS CONSIDERED TO BE RELEVANT		
Category *	Citation of document, with indication, where appropriate, of the relevant passages	Relevant to claim No.
A	<p>LEBENSMITTEL-WISSENSCHAFT UND-TECHNOLOGIE, vol. 26, no. 4, 1993, LONDON UK, pages 312-317, XP000610486 B. DAVE OOMAH AND G. MAZZA: "Processing of Flaxseed Meal: Effect of Solvent Extraction on Physicochemical Characeristics" see the whole document ---</p>	1
A	<p>JOURNAL OF THE AMERICAN OIL CHEMISTS' SOCIETY, vol. 71, no. 6, 1 June 1994, pages 603-607, XP000450510 VARGA T K ET AL: "SIMULTANEOUS EXTRACTION OF OIL AND ANTINUTRITIONAL COMPOUNDS FROM FLAXSEED" see the whole document -----</p>	1