

B. B. BROYLES.

Improvement in Grain and Middlings Feeder for Millstones.

No. 128,702.

Patented July 9, 1872.

Fig. 1.

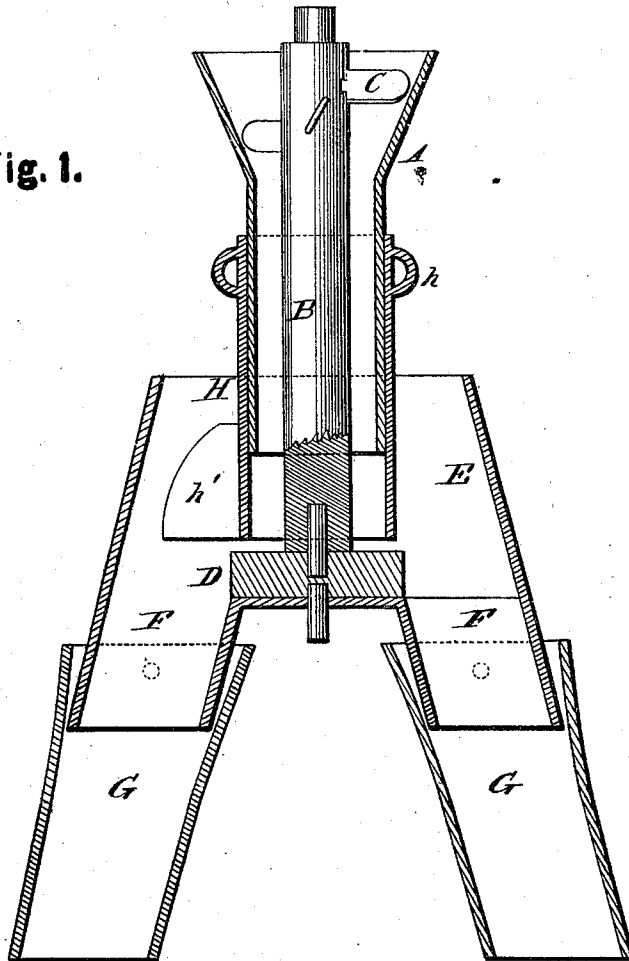

WITNESSES.

*E. A. Bates*  
*George C. Mopham.*

INVENTOR.

*Benjamin B. Broyles,*  
*Chipman Hosmer & Co.,*  
*Atty.*

B. B. BROYLES.

Improvement in Grain and Middlings Feeder for Millstones.

No. 128,702.

Patented July 9, 1872.

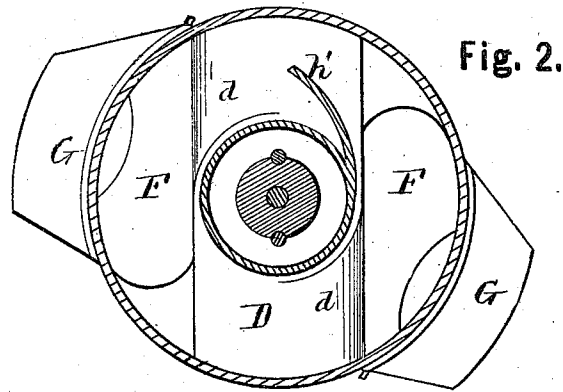

WITNESSES.

*E. A. Bates*  
*J. A. Armolly*

INVENTOR.

*B. B. Broyles*  
*Chipman & Sons Co.,*  
*Utica,*

# UNITED STATES PATENT OFFICE.

BENJAMIN B. BROYLES, OF FREEDOM, TENNESSEE.

IMPROVEMENT IN GRAIN AND MIDLINGS FEEDERS FOR MILLSTONES.

Specification forming part of Letters Patent No. 128,702, dated July 9, 1872.

*To all whom it may concern:*

Be it known that I, BENJAMIN B. BROYLES, of Freedom, in the county of Washington and State of Tennessee, have invented a new and valuable Improvement in Middlings and Grain Feeder; and I do hereby declare that the following is a full, clear, and exact description of the construction and operation of the same, reference being had to the annexed drawing making a part of this specification, and to the letters and figures of reference marked thereon.

Figure 1 of the drawing is a representation of a vertical section of my invention. Fig. 2 is a plan section of the piece D.

This invention has relation to grain or middlings feeders for millstones; and consists in the construction and novel arrangement of an apparatus through which the grain is conducted from the hopper to the stones, and which operates to scatter said grain in the proper manner for grinding, and is furnished with means of adjustment for the regulation of the feed according to the speed of the stones, all substantially as hereinafter described.

In the drawing, A represents a hopper, through which passes a vertical shaft, B, armed with beaters C to loosen and draw the grain down toward the stones. At its lower end said shaft is attached to a transverse or horizontal piece, D, arranged within a funnel or feeding-box, E, constructed with two short tubes, F, depending from opposite sides of the piece D. These tubes pass into and are hinged to extensions G. Said tubes, together with the extensions G, diverge from their upper to their lower ends. The extensions, being hinged, may be brought toward each other at their lower ends for the purpose of being inserted in the eye of the stone, after which, the bottom of the box E being placed on the balance-rim, said extensions spread apart above the face of the lower stone. The whole of the apparatus, with the exception of the hopper A and the regulating-tube H, rotate with the upper stone. The grain or middlings passes down through the hopper-tube, and runs off on either side of the piece D into the tubes F, and thence to the stones. The piece

D is to be made of highly-polished metal, to which nothing will adhere. The sides of said piece are parallel. The upper surface is formed with convex inclines *d*, located at either end and on opposite sides of the piece D. The side terminations of said inclines are respectively at the ends of the piece D, and at curved shoulders concentric with the shaft B. The grain or middlings escaping from the lower end of the regulating-tube runs down these inclines, which, it will be noticed, conduct directly to the tubes F. The tube H, which is raised or lowered to regulate the feed to the tubes F, and for such purpose is furnished near its upper end with loops *h*, is also provided with a curved wing, *h'*, projecting near its lower end, and adapted to push the grain or middlings toward the inclines leading to the tubes F, and thus keep the lower end of the tube H clear. The wing or arm *h'*, besides being curved, is placed at an angle so as to press downward. When the regulating-tube is properly adjusted some convenient means must be employed to retain it in position. The loops *n* offer convenient facilities for coupling any supports.

To prevent the accumulation of grain or middlings around the base of the funnel E the mouths of the tubes F are so shaped as to leave no ledges or resting places in the way of the grain or middlings. The sides of the tubes nearest the piece D are therefore flattened and made flush with the sides of said piece. The outer sides of the tubes coincide with the form of the funnel E. The upper parts of the extensions G coincide with the tubes F. In this way the flat surfaces serve as a lock to prevent the tubes G from being brought closer together than necessary. The lower ends of the extensions may be either circular, oval, or otherwise shaped, as desired.

What I claim as my invention, and desire to secure by Letters Patent, is—

1. The feeding apparatus for millstones, having the hopper A, shaft B with arms C, piece D with incline *d*, and funnel E with depending tubes F, all constructed and combined substantially as and for the purpose specified.

2. The vertically-adjustable regulating-tube

H, having the wing *h'*, in combination with the hopper A, funnel E, and tubes F, substantially as described.

3. The extension tubes G hinged to the tubes F of a millstone-feeder, all constructed substantially as described.

In testimony that I claim the above I have

hereunto subscribed my name in the presence of two witnesses.

BENJAMIN BAINBRIDGE BROYLES.

Witnesses:

JOHN B. KLEPPER,

THOMAS KLEPPER.