



US 20130138153A1

(19) **United States**
(12) **Patent Application Publication**
Jackson

(10) **Pub. No.: US 2013/0138153 A1**
(43) **Pub. Date: May 30, 2013**

(54) **DYNAMIC STABILIZATION ASSEMBLY
HAVING PRE-COMPRESSED SPACERS WITH
DIFFERENTIAL DISPLACEMENTS**

filed on Aug. 1, 2008, provisional application No. 60/927,111, filed on May 1, 2007, provisional application No. 60/932,567, filed on May 31, 2007, provisional application No. 60/994,068, filed on Sep. 17, 2007.

(71) Applicant: **Roger P. Jackson**, Prairie Village, KS (US)

(72) Inventor: **Roger P. Jackson**, Prairie Village, KS (US)

(21) Appl. No.: **13/694,982**

(22) Filed: **Jan. 23, 2013**

Publication Classification

(51) **Int. Cl.**
A61B 17/70 (2006.01)
(52) **U.S. Cl.**
CPC *A61B 17/7049* (2013.01)
USPC **606/264**

Related U.S. Application Data

(63) Continuation of application No. 12/459,492, filed on Jul. 1, 2009, now Pat. No. 8,366,745, which is a continuation-in-part of application No. 12/148,465, filed on Apr. 18, 2008, said application No. 12/459,492 is a continuation-in-part of application No. 12/156,260, filed on May 30, 2008, now Pat. No. 7,951,170.

(60) Provisional application No. 61/134,480, filed on Jul. 10, 2008, provisional application No. 61/137,743,

(57) **ABSTRACT**

A dynamic longitudinal connecting member assembly includes an anchor member having an integral or otherwise fixed elongate core extending through at least two elastic spacers and at least one outer sleeve or trolley. The anchor member and the outer sleeve each attach to at least one bone anchor. The spacers have differing durometers and/or geometries, resulting in greater axial movement of the sleeve in one direction than in an opposite direction. The spacers are compressed prior to attachment to the bone anchors.

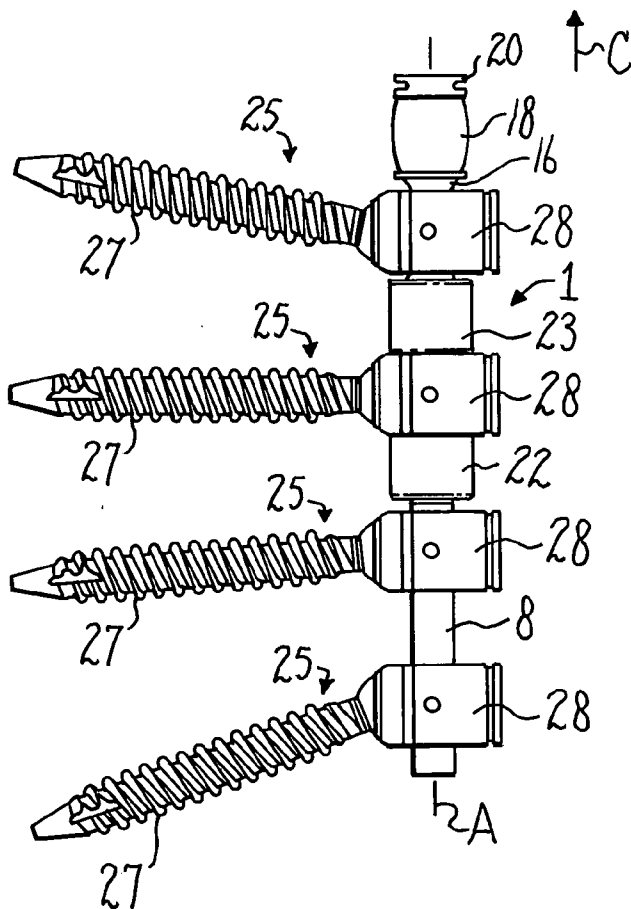

Fig. 1.

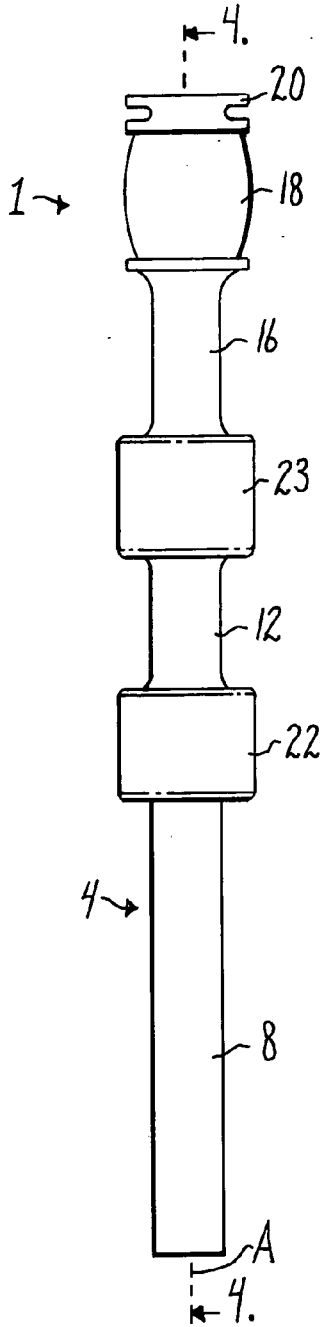

Fig. 2.

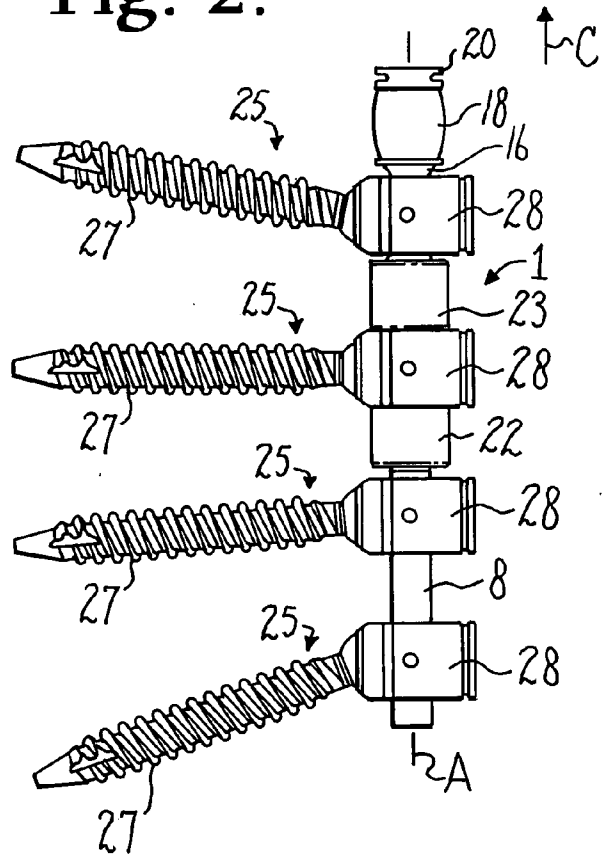

Fig. 3.

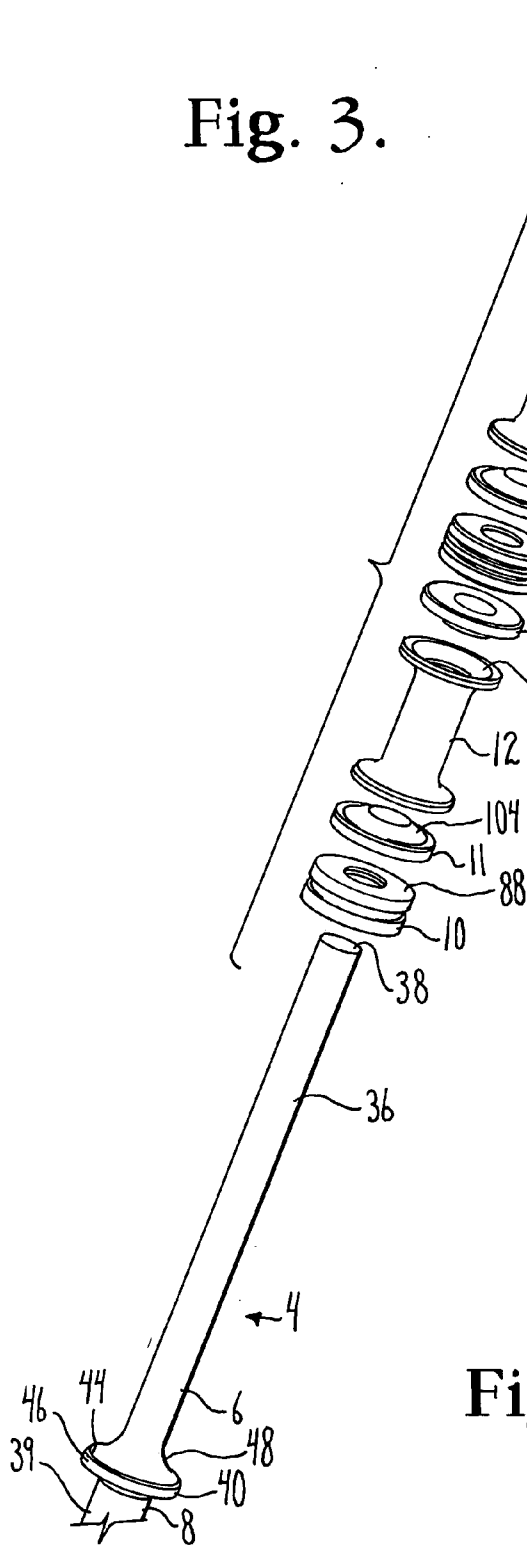

Fig. 4.

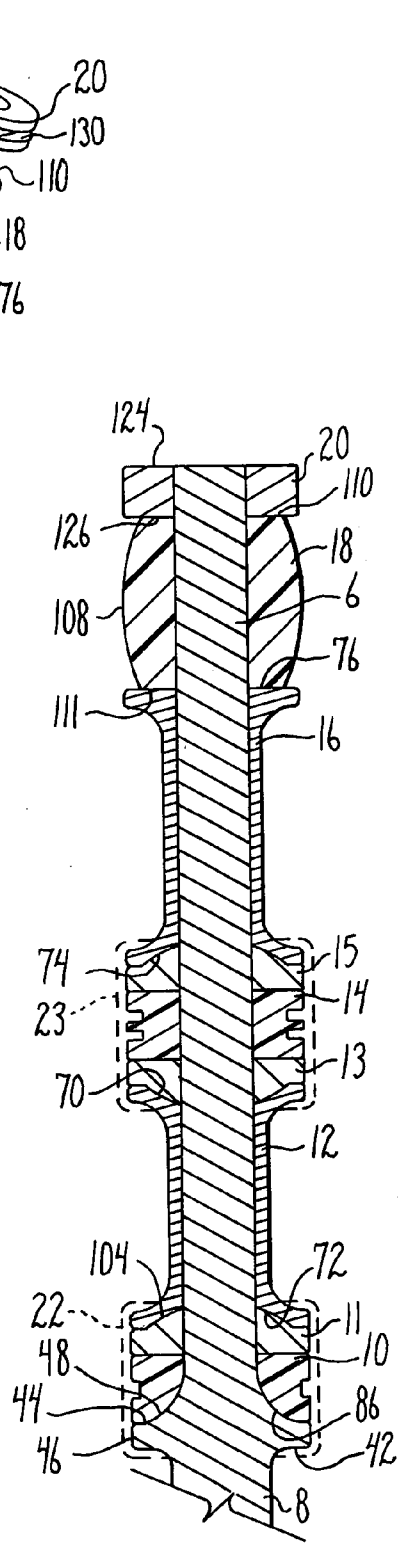

Fig. 5

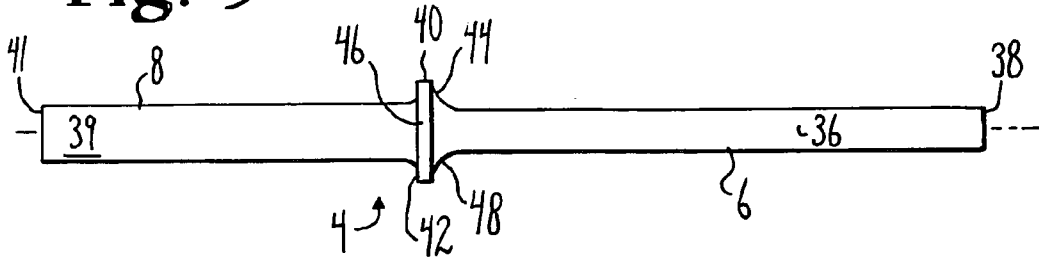

Fig. 6.

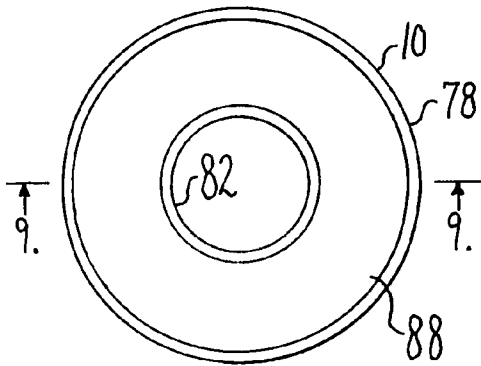

Fig. 8.

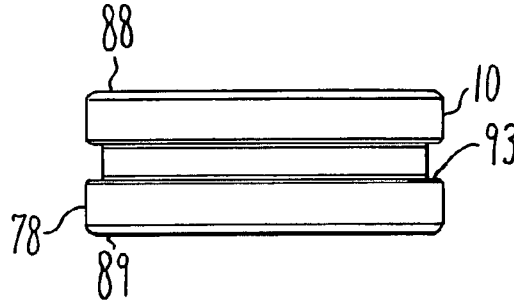

Fig. 7.

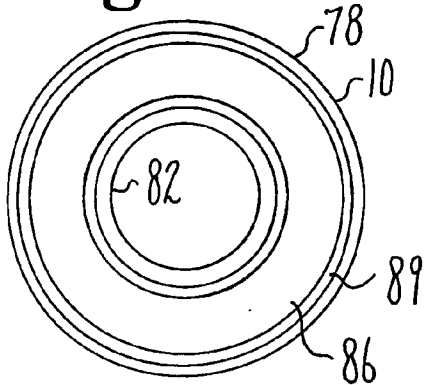

Fig. 9.

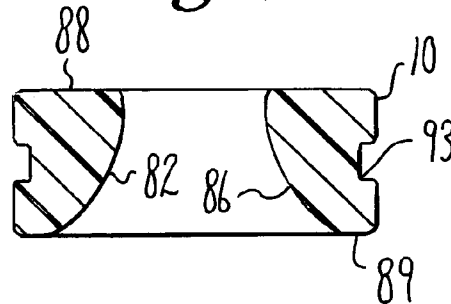

Fig. 10.

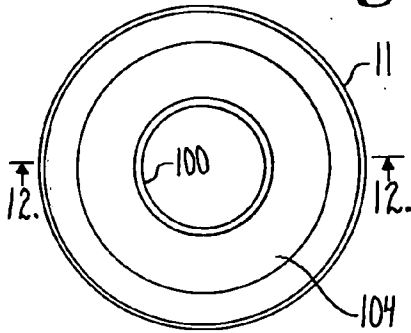

Fig. 11.

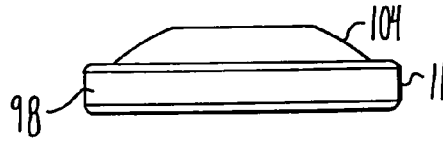

Fig. 12.

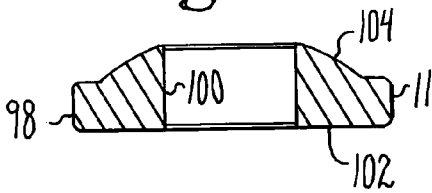

Fig. 14.

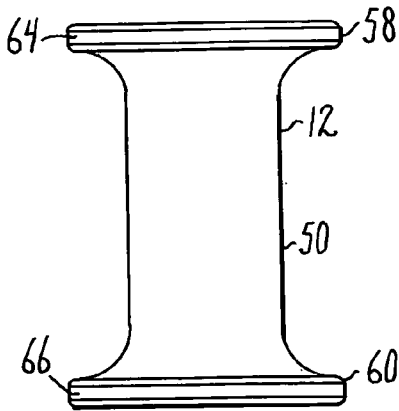
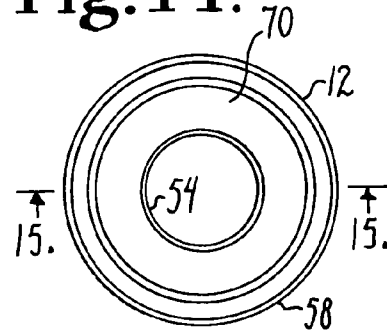

Fig. 13.

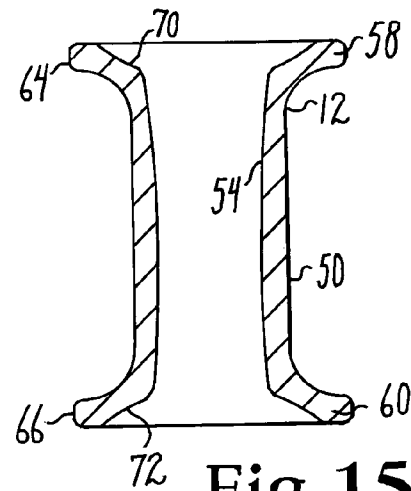

Fig. 15.

Fig. 16.

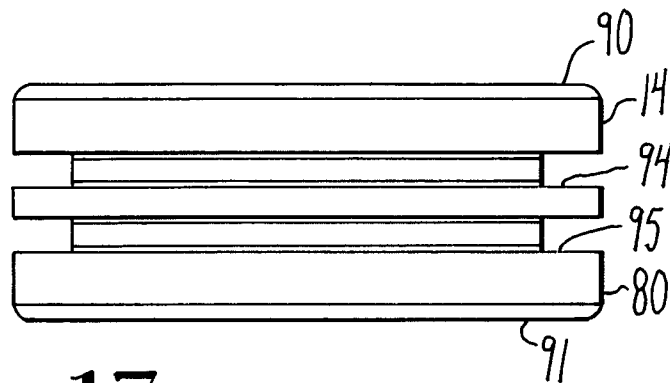
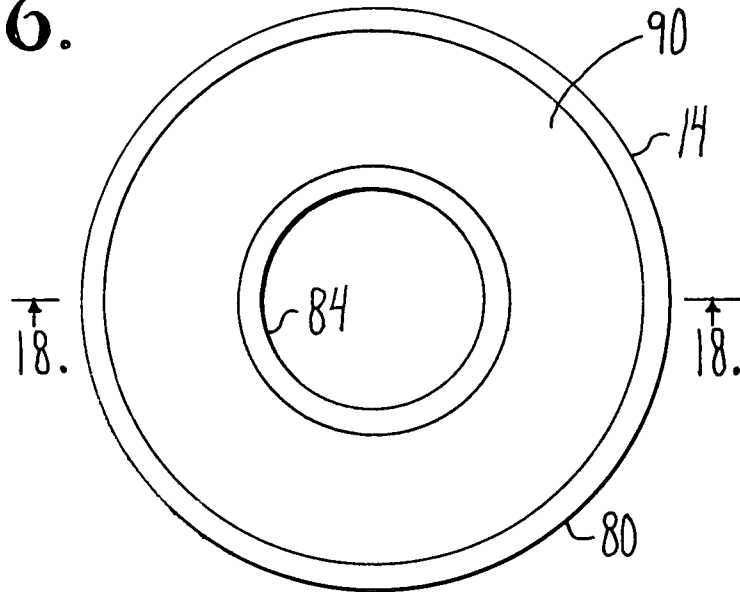

Fig. 17.

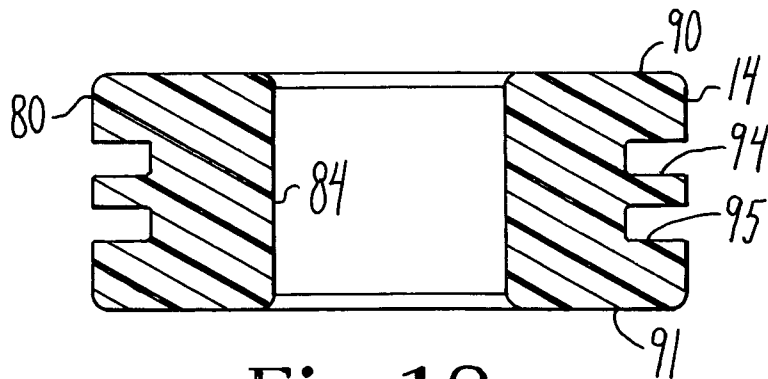

Fig. 18.

Fig.19.

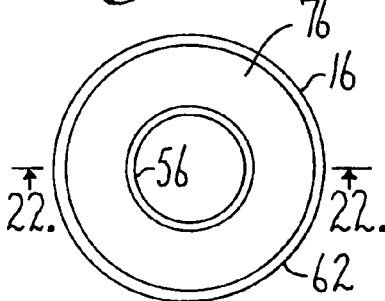

Fig.20.

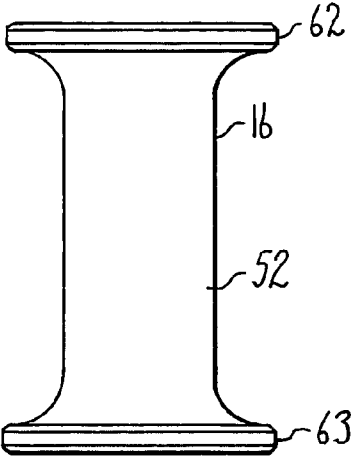
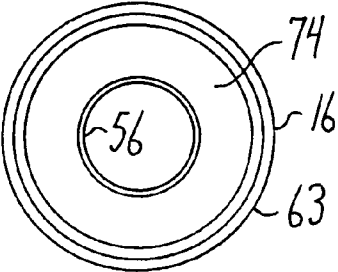

Fig.21.

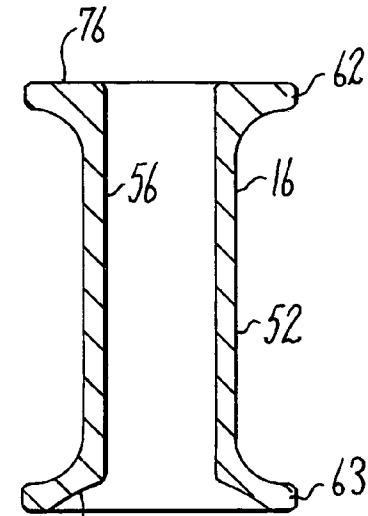

Fig.22.

Fig. 23.

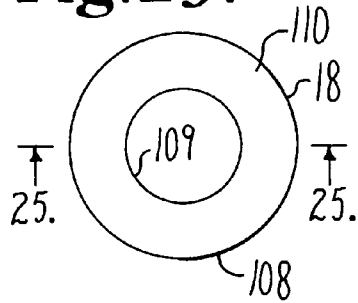

Fig. 24.

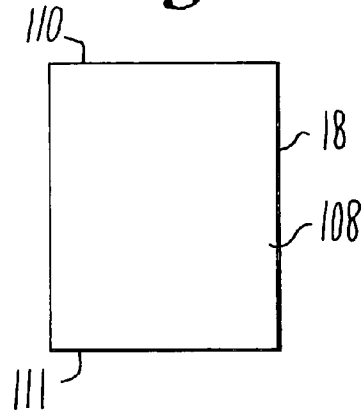

Fig. 25.

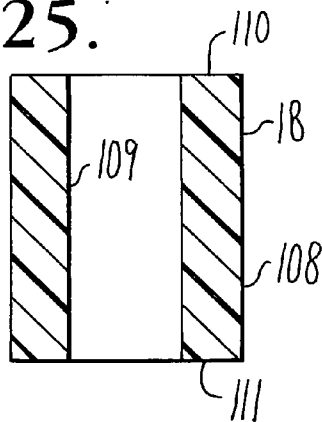

Fig. 27.

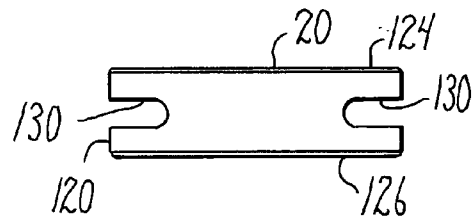

Fig. 26.

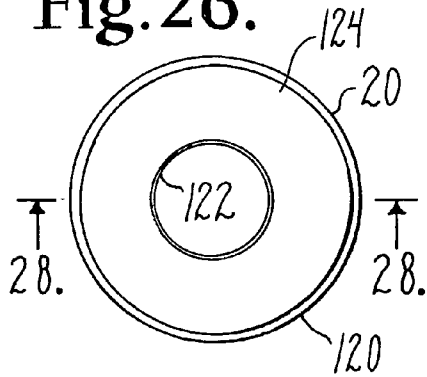
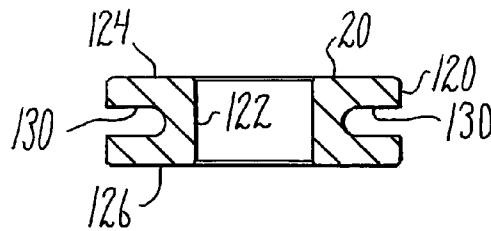
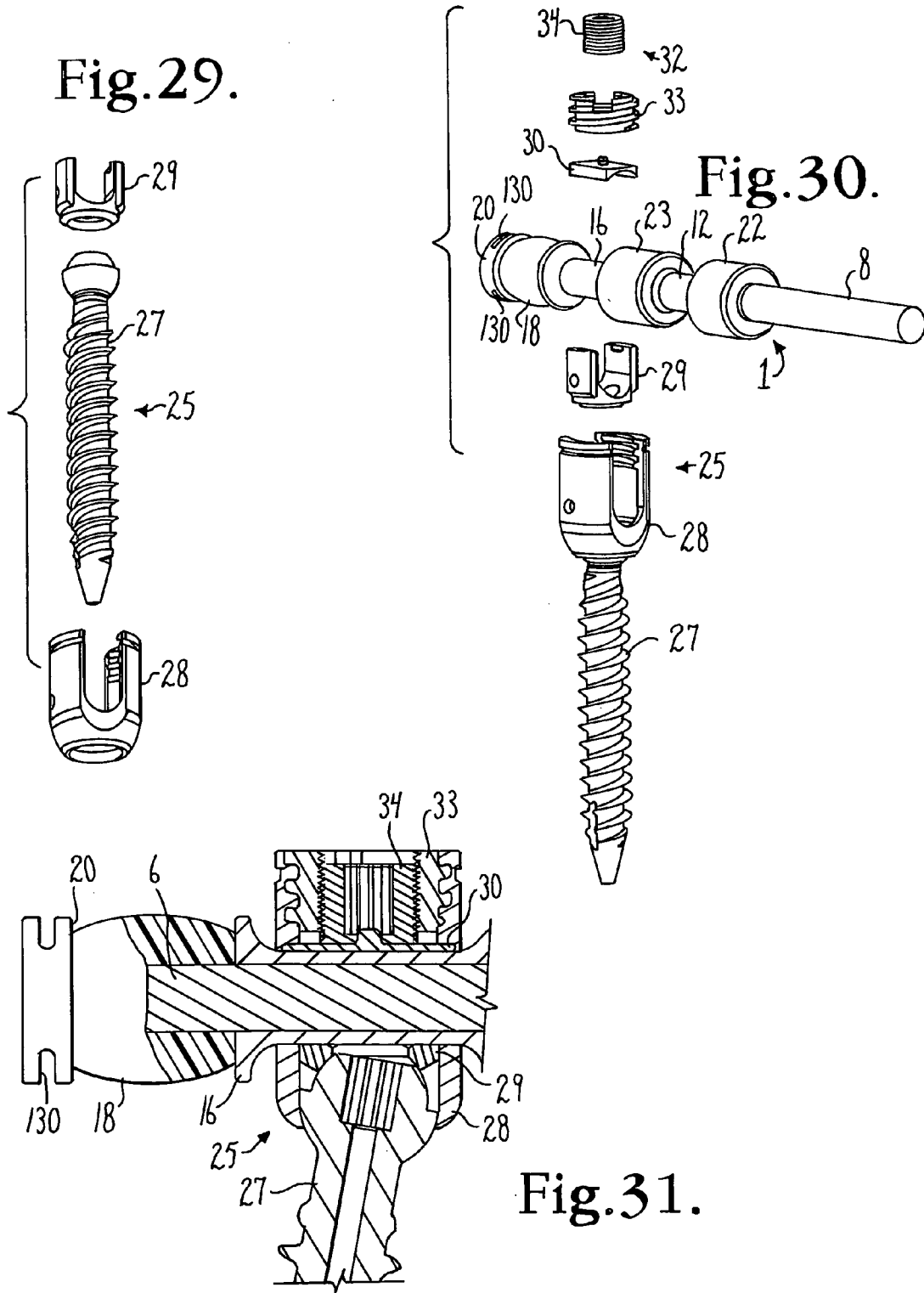

Fig. 28.





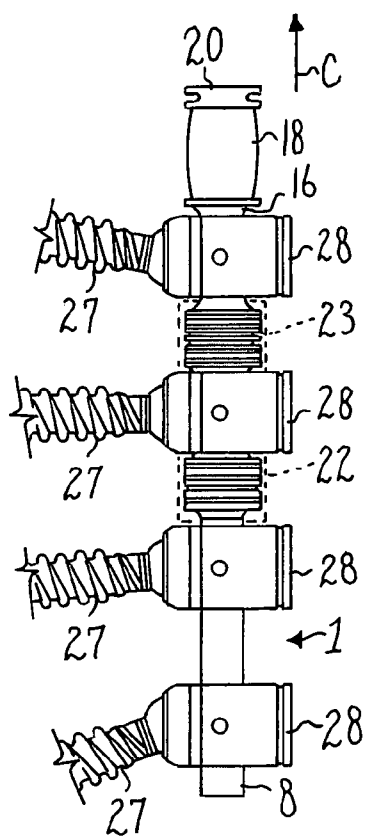

Fig.32.

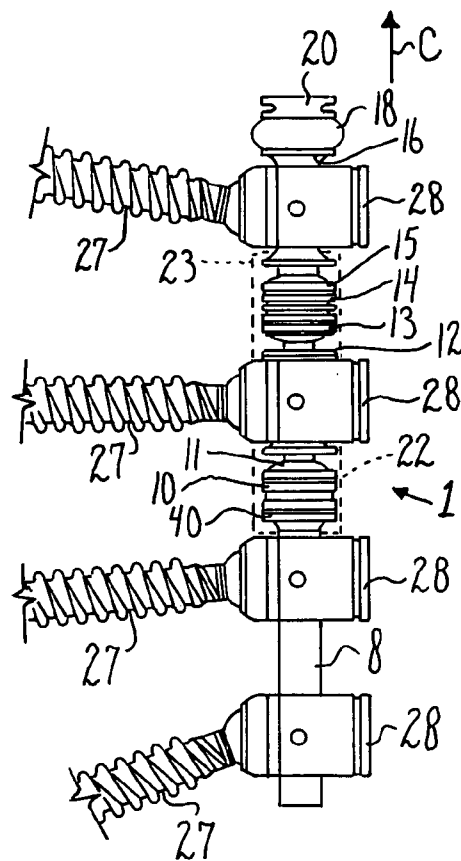

Fig.33.

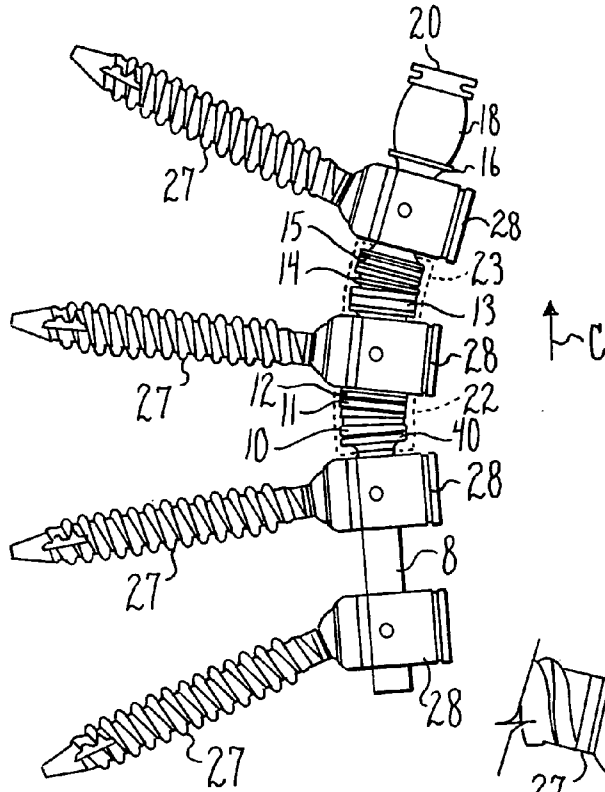

Fig. 34.

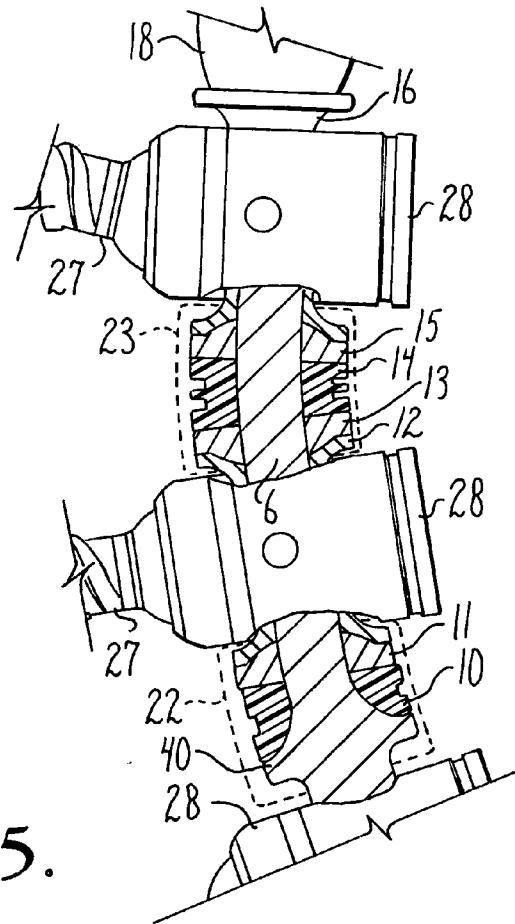

Fig. 35.

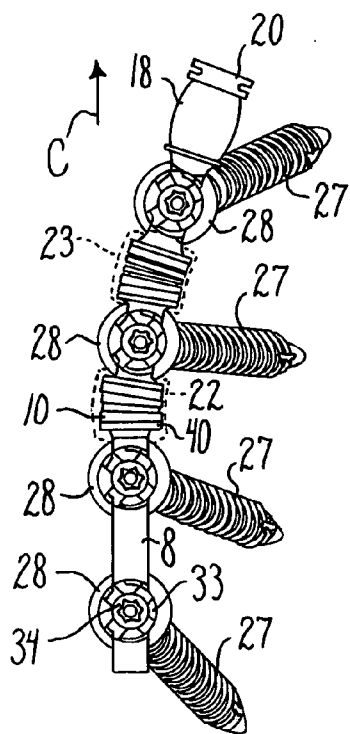

Fig. 36.

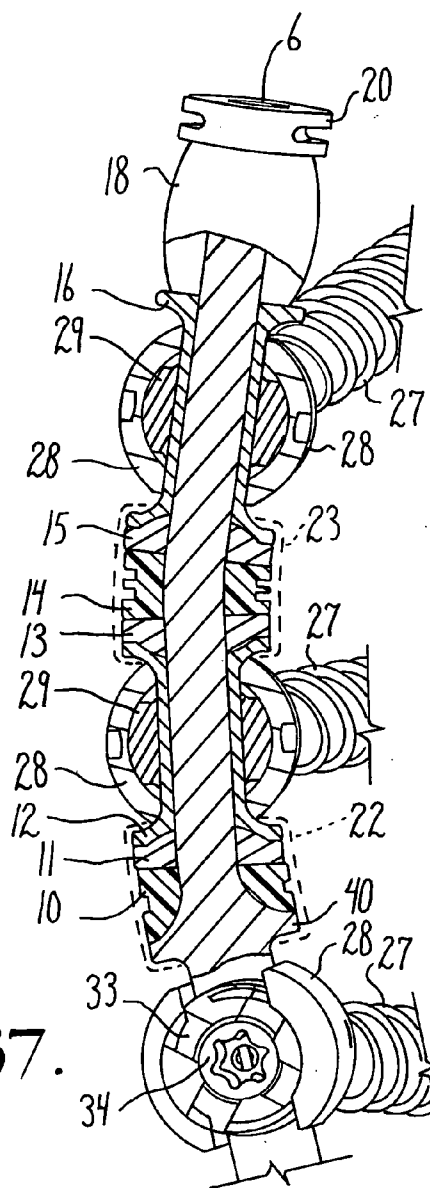

Fig. 37.

Fig.38.

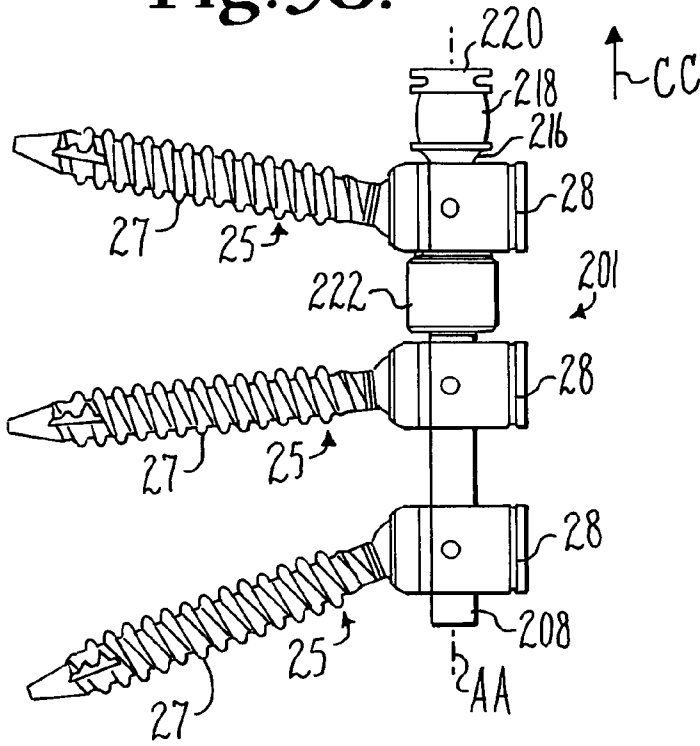

Fig.39.

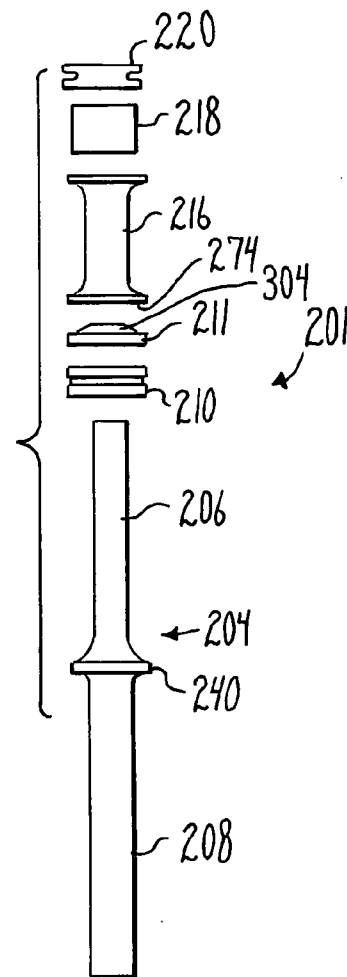

Fig. 40.

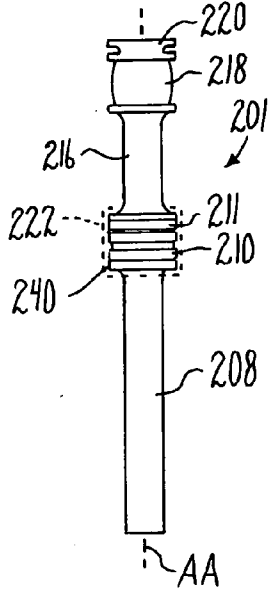

Fig. 41.

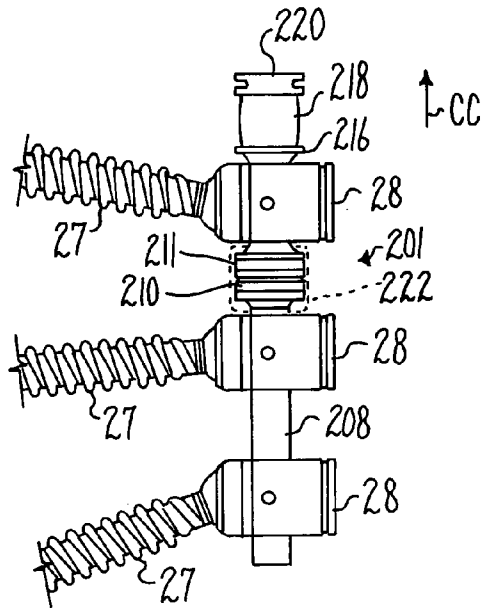

Fig. 42.

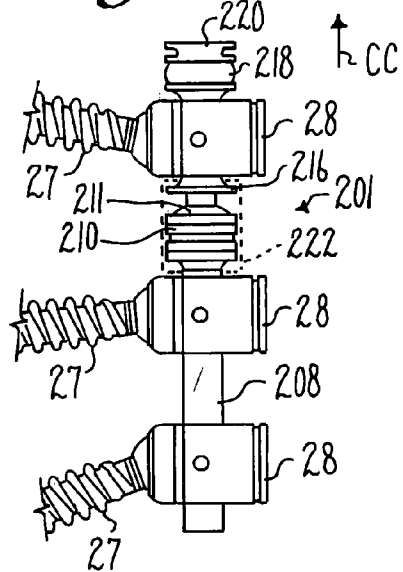
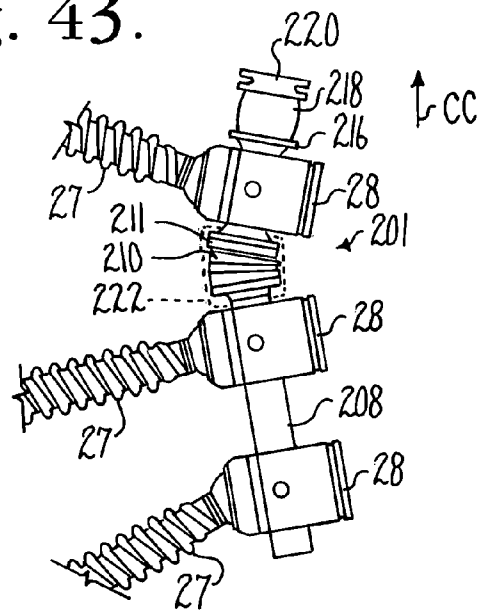

Fig. 43.



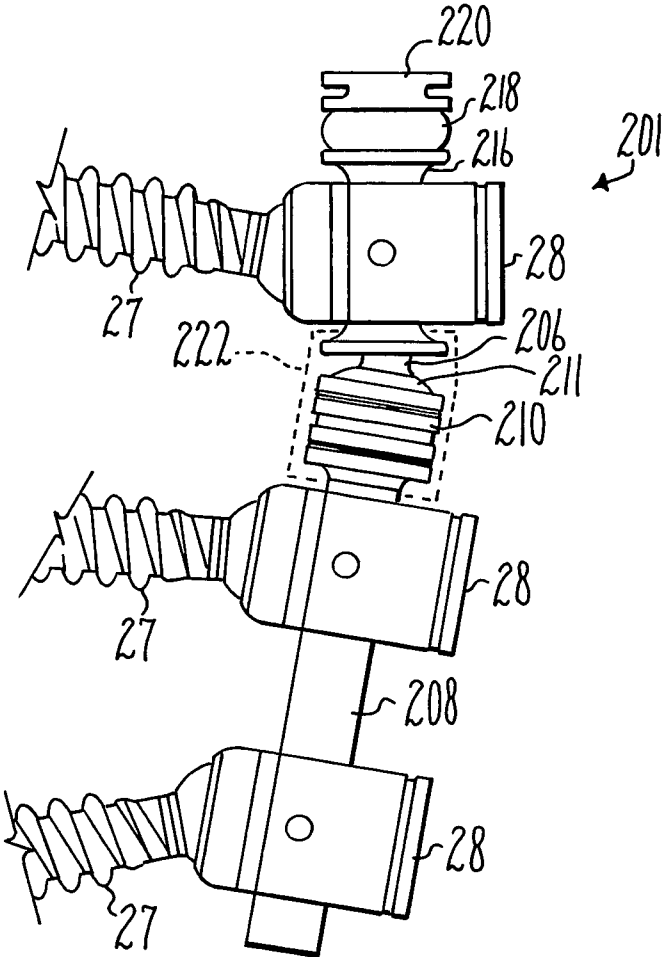

Fig. 44.

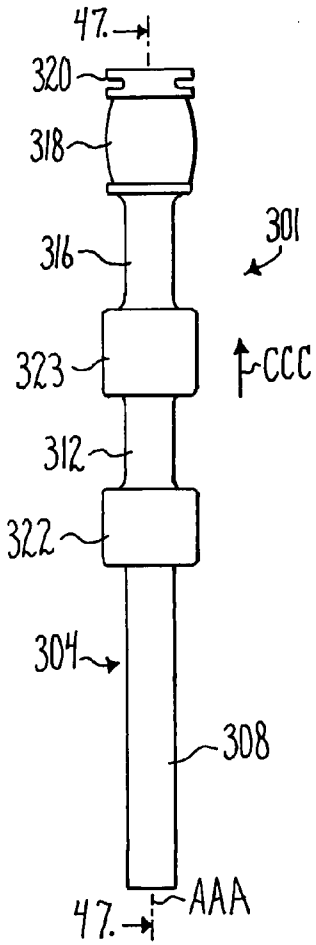

Fig. 45.

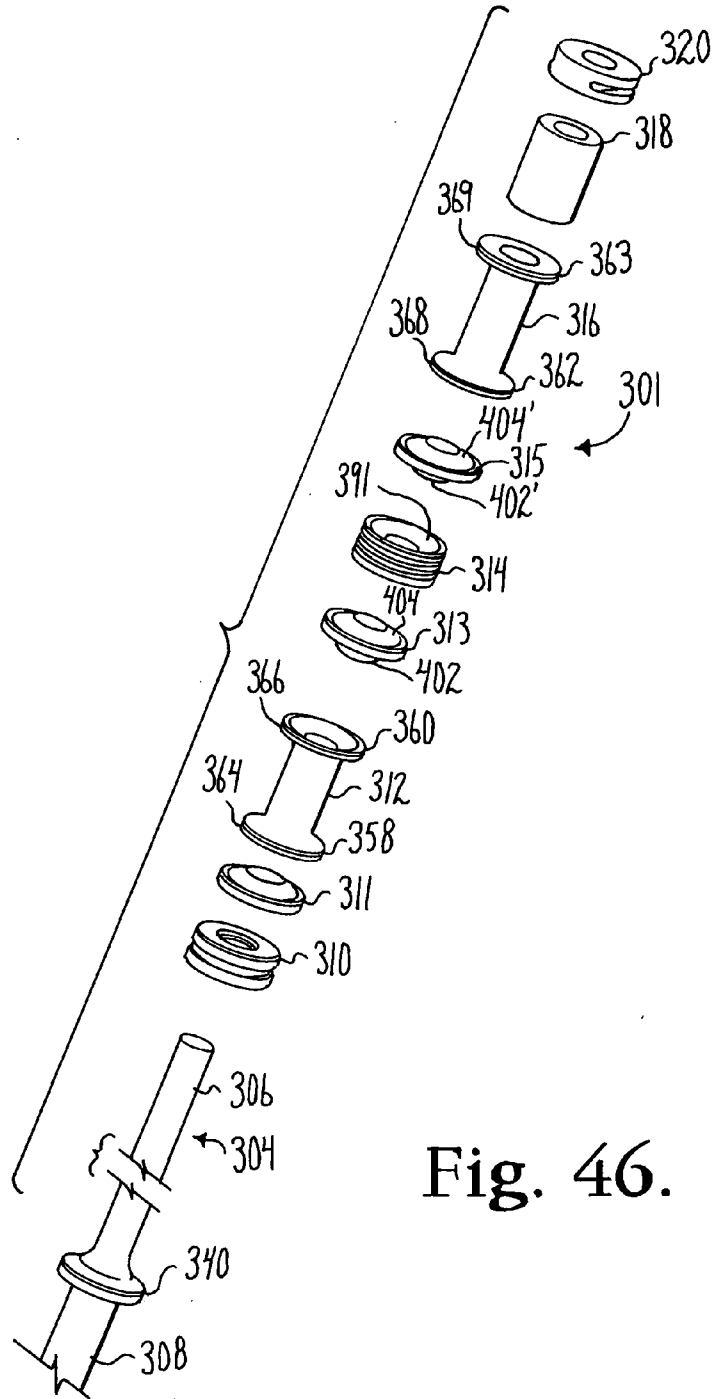
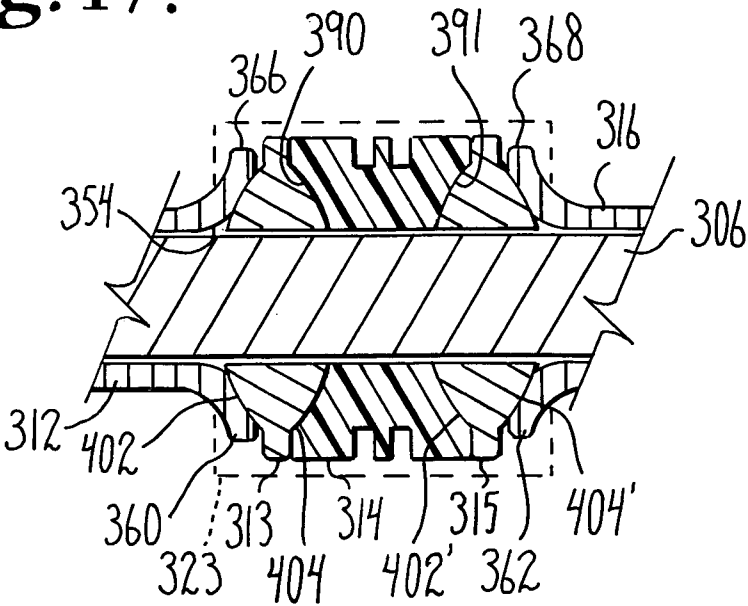

Fig. 46.

Fig.47.



**DYNAMIC STABILIZATION ASSEMBLY
HAVING PRE-COMPRESSED SPACERS WITH
DIFFERENTIAL DISPLACEMENTS**

**CROSS-REFERENCE TO RELATED
APPLICATIONS**

[0001] This application is a continuation of U.S. patent application Ser. No. 12/459,492, filed Jul. 1, 2009 which claimed the benefit of U.S. Provisional Patent Application Ser. No. 61/134,480, filed Jul. 10, 2008 and claimed the benefit of U.S. Provisional Patent Application Ser. No. 61/137,743, filed Aug. 1, 2008, all of which are incorporated by reference herein. U.S. application Ser. No. 12/459,492 is also a continuation-in-part of U.S. patent application Ser. No. 12/148,465, filed Apr. 18, 2008, that claims the benefit of U.S. Provisional Patent Application Ser. No. 60/927,111, filed May 1, 2007, all of which are incorporated by reference herein. Application Ser. No. 12/459,492 is also a continuation-in-part of U.S. patent application Ser. No. 12/156,260, filed May 30, 2008, now U.S. Pat. No. 7,951,170, issued May 31, 2011, that claimed the benefit of U.S. Provisional Patent Application Ser. No. 60/932,567, filed May 31, 2007, and the benefit of U.S. Provisional Patent Application Ser. No. 60/994,068, filed Sep. 17, 2007, all of which are incorporated by reference herein.

BACKGROUND OF THE INVENTION

[0002] The present invention is directed to dynamic fixation assemblies for use in bone surgery, particularly spinal surgery, and in particular to longitudinal connecting members and cooperating bone anchors or fasteners for such assemblies, the connecting members being attached to at least two bone anchors.

[0003] Historically, it has been common to fuse adjacent vertebrae that are placed in fixed relation by the installation therealong of bone screws or other bone anchors and cooperating longitudinal connecting members or other elongate members. Fusion results in the permanent immobilization of one or more of the intervertebral joints. Because the anchoring of bone screws, hooks and other types of anchors directly to a vertebra can result in significant forces being placed on the vertebra, and such forces may ultimately result in the loosening of the bone screw or other anchor from the vertebra, fusion allows for the growth and development of a bone counterpart to the longitudinal connecting member that can maintain the spine in the desired position even if the implants ultimately fail or are removed. Because fusion has been a desired component of spinal stabilization procedures, longitudinal connecting members have been designed that are of a material, size and shape to largely resist bending (flexion, extension and lateral), torsion, shear, distraction and compression, and thus substantially immobilize the portion of the spine that is to be fused. Thus, longitudinal connecting members are typically uniform along an entire length thereof, and usually made from a single or integral piece of material having a uniform diameter or width of a size to provide substantially inelastic rigid support in all planes.

[0004] An alternative to fusion, which immobilizes at least a portion of the spine, and the use of more rigid longitudinal connecting members or other rigid structure has been a "soft" or "dynamic" stabilization approach in which a flexible loop-, S-, C- or U-shaped member or a coil-like and/or a spring-like member is utilized as an elastic longitudinal connecting

member fixed between a pair of pedicle screws in an attempt to create, as much as possible, a normal loading pattern between the vertebrae in flexion, extension, side bending, distraction, compression and torsion. Another type of soft or dynamic system known in the art includes bone anchors connected by flexible cords or strands, typically made from a plastic material. Such a cord or strand may be threaded through cannulated spacers that are disposed between adjacent bone anchors when such a cord or strand is implanted, tensioned and attached to the bone anchors. The spacers typically span the distance between bone anchors, providing limits on the bending, movement of the cord or strand and thus strengthening and supporting the overall system. Shear forces are not well resisted by the typical cord and spacer stabilization systems. Such tensioned cord and spacer systems may also cause facet joint compression during spinal movement, especially flexion.

[0005] The complex dynamic conditions associated with spinal movement create challenges for the design of elongate elastic longitudinal connecting members that exhibit an adequate fatigue strength to provide stabilization and protected motion of the spine, without fusion, and that allow for some natural movement of the portion of the spine being reinforced and supported by the elongate elastic or flexible connecting member. A further challenge are situations in which a portion or length of the spine requires a more rigid stabilization, possibly including fusion, while another portion or length may be better supported by a more dynamic system that allows for protective movement.

SUMMARY OF THE INVENTION

[0006] A longitudinal connecting member assembly according to the invention has an inner elongate core of circular or non-circular cross-section that is integral or otherwise fixed to a first bone anchor attachment portion. A first elastic spacer surrounds the core and is slidable along the core at a location between a pair of adjacent bone anchors. At least one outer inelastic sleeve or tube-like trolley member also surrounds the core and is in sliding relationship with the core. The outer sleeve also engages at least one bone anchor. A second elastic spacer of durometer or geometry differing from the first elastic spacer also surrounds the core and is located at a side of the at least one sleeve member opposite the first elastic spacer. The inner core, elastic spacers and inelastic sleeve or sleeves cooperate dynamically, with the spacers being at least somewhat pre-compressed resulting in little-to-no or more substantial deformation of the spacers prior to insertion, and controlling movement of the sleeve allowing greater travel of the sleeve along the core in a single direction; for example, advantageously allowing greater operative travel of the sleeve in a cephalad or cranial direction and more limited movement in a caudal or caudad direction after insertion. In addition, in certain embodiments, the sleeve or tube trolley members feature inner surfaces having non-linear relief for improved core member function with respect to bending stress, wear and fatigue life concerns.

[0007] In another embodiment, an improved longitudinal connecting member adapted for cooperating with a plurality of bone anchors that are implanted in a patient's spine is provided, wherein the longitudinal connecting member includes a substantially rigid anchor portion that extends along a longitudinal axis of the connecting member and is joined with a core portion that also extends along the longitudinal axis. The anchor portion formed of a first material and

the core portion is formed of a second material. The core portion includes a reduced diameter relative to the anchor portion, such that the second material and the reduced diameter cooperate so as to enable at least some flexing of the core portion. The anchor portion is directly engaged by first and second bone anchors while the core portion is indirectly engaged by a third bone anchor. Furthermore, the longitudinal connection member provides for greater movement in the cephalad direction than in the caudad direction.

[0008] A first inelastic sleeve is slidably received over the core portion so as to be located between the third bone anchor and the core portion. A pair of elastic spacers is received over the core portion such that each of the spacers is adjacent to an end of the first sleeve. A crimp ring engages the core portion and is located so as to bias the spacers. Additionally, an elastic over-mold surrounds at least one of the spacers and a respective adjacent end of the first sleeve.

[0009] In a further embodiment, the elastic over-mold grips both the anchor portion and the first sleeve.

[0010] In another further embodiment, the anchor portion includes a first end plate and the elastic over-mold is molded about the first end plate.

[0011] In some further embodiments, the elastic over-mold is made from a composite material comprising elongate reinforcement strands imbedded in a polymer.

[0012] In some further embodiments, the core is made from a polymer. Furthermore, in some embodiments, the polymer is polyetheretherketone.

[0013] In another further embodiment, the first sleeve substantially blocks flexing of the portion of the core that is surrounded by the first sleeve. Additionally, in some embodiments, the core flexes primarily between the first sleeve and the anchor portion.

[0014] In yet another further embodiment, the longitudinal connecting member also includes a second inelastic sleeve slidably received over the core portion so as to be located between a fourth bone anchor and the core portion; a third elastic spacer received over the core portion so as to be located between the second inelastic sleeve and the crimp ring; and a second elastic over-mold surrounding a second end of the first sleeve, the third spacer and an adjacent end of the second sleeve. In some embodiments, the first sleeve substantially blocks flexing of the portion of the core that is surrounded by the first sleeve; and the second sleeve substantially blocks flexing of the portion of the core that is surrounded by the second sleeve. Accordingly, in some embodiments, the core flexes primarily between the first sleeve and the anchor portion; and between the first sleeve and the second sleeve.

Objects and Advantages of the Invention

[0015] An object of the invention is to provide dynamic medical implant stabilization assemblies having longitudinal connecting members that include a flexible, pre-tensioned portion that can allow for controlled bending, torsion, compression and distraction of the assembly. Another object of the invention is to provide such an assembly including elastic pre-compressed spacers of various durometers and/or geometries. A further object of the invention is to provide dynamic medical implant longitudinal connecting members that may be utilized with a variety of bone screws, hooks and other bone anchors. Additionally, it is an object of the invention to provide a lightweight, reduced volume, low profile assembly including at least two bone anchors and a longitudinal con-

necting member therebetween. Furthermore, it is an object of the invention to provide apparatus and methods that are easy to use and especially adapted for the intended use thereof and wherein the apparatus are comparatively inexpensive to make and suitable for use.

[0016] Other objects and advantages of this invention will become apparent from the following description taken in conjunction with the accompanying drawings wherein are set forth, by way of illustration and example, certain embodiments of this invention.

[0017] The drawings constitute a part of this specification and include exemplary embodiments of the present invention and illustrate various objects and features thereof.

BRIEF DESCRIPTION OF THE DRAWINGS

[0018] FIG. 1 is an enlarged side elevational view of a dynamic fixation connecting member assembly according to the invention.

[0019] FIG. 2 is a reduced side elevational view of the assembly of FIG. 1 shown with four bone screws and in an operative position with respect to a human spine.

[0020] FIG. 3 is an enlarged and partial exploded perspective view of the assembly of FIG. 1 including a solid core anchor, a first differential compression spacer, a first pressure washer, a first sleeve, a second pressure washer, a second differential compression spacer, a third pressure washer, a second sleeve, an elastic bumper and a crimping ring.

[0021] FIG. 4 is an enlarged and partial cross-sectional view taken along the line 4-4 of FIG. 1 and with two optional over-molded coverings shown in phantom.

[0022] FIG. 5 is an enlarged side elevational view of the solid core anchor of FIG. 3.

[0023] FIG. 6 is an enlarged top plan view of the first differential compression spacer of FIG. 3.

[0024] FIG. 7 is an enlarged bottom plan view of the first spacer of FIG. 3.

[0025] FIG. 8 is an enlarged side elevational view of the first spacer of FIG. 3.

[0026] FIG. 9 is an enlarged cross-sectional view taken along the line 9-9 of FIG. 6.

[0027] FIG. 10 is an enlarged top plan view of the first pressure washer of FIG. 3.

[0028] FIG. 11 is an enlarged side elevational view of the first pressure washer of FIG. 3.

[0029] FIG. 12 is an enlarged cross-sectional view taken along the line 12-12 of FIG. 10.

[0030] FIG. 13 is an enlarged side elevational view of the first sleeve of FIG. 3.

[0031] FIG. 14 is an enlarged top plan view of the first sleeve of FIG. 3.

[0032] FIG. 15 is an enlarged cross-sectional view taken along the line 15-15 of FIG. 14.

[0033] FIG. 16 is an enlarged top plan view of the second spacer of FIG. 3.

[0034] FIG. 17 is an enlarged side elevational view of the second spacer of FIG. 3.

[0035] FIG. 18 is an enlarged cross-sectional view taken along the line 18-18 of FIG. 16.

[0036] FIG. 19 is, an enlarged top plan view of the second sleeve of FIG. 3.

[0037] FIG. 20 is an enlarged bottom plan view of the second sleeve of FIG. 3.

[0038] FIG. 21 is an enlarged side elevational view of the second sleeve of FIG. 3.

[0039] FIG. 22 is an enlarged cross-sectional view taken along the line 22-22 of FIG. 19.

[0040] FIG. 23 is an enlarged top plan view of the bumper of FIG. 3.

[0041] FIG. 24 is an enlarged side elevational view of the bumper of FIG. 3.

[0042] FIG. 25 is an enlarged cross-sectional view taken along the line 25-25 of FIG. 23.

[0043] FIG. 26 is an enlarged top plan view of the crimping ring of FIG. 3.

[0044] FIG. 27 is an enlarged side elevational view of the crimping ring of FIG. 3.

[0045] FIG. 28 is an enlarged cross-sectional view taken along the line 28-28 of FIG. 26.

[0046] FIG. 29 is an enlarged exploded perspective view of a portion of one of the bone screws shown in FIG. 2.

[0047] FIG. 30 is an enlarged perspective view of the connecting member of FIG. 1 shown with one of the bone screws of FIG. 2 in exploded perspective view.

[0048] FIG. 31 is an enlarged and partial side elevational view of the assembly of FIG. 1, shown with a bone screw of FIG. 2, with portions broken away to show the detail thereof.

[0049] FIG. 32 is a partial side elevational view of the assembly of FIGS. 1 and 2 with optional over-molds shown in phantom and with differential displacement in a caudal direction.

[0050] FIG. 33 is a partial side elevational view of the assembly of FIGS. 1 and 2 with optional over-molds shown in phantom and with differential displacement in a cephalad direction.

[0051] FIG. 34 is a side elevational view of the assembly of FIGS. 1 and 2 with optional over-molds shown in phantom and shown operatively responding to spinal extension or lordosis.

[0052] FIG. 35 is an enlarged and partial side elevational view, similar to FIG. 34 with portions broken away to show the detail thereof.

[0053] FIG. 36 is a rear elevational view of the assembly of FIGS. 1 and 2 with optional over-molds shown in phantom and shown operatively responding to spinal scoliosis.

[0054] FIG. 37 is an enlarged and partial rear elevational view, similar to FIG. 36 with portions broken away to show the detail thereof.

[0055] FIG. 38 is an enlarged side elevational view of a second embodiment of a dynamic connecting member assembly according to the invention shown with three bone screws.

[0056] FIG. 39 is an enlarged and exploded side elevational view of the assembly of FIG. 38.

[0057] FIG. 40 is an enlarged side elevational view of the assembly of FIG. 38 with the optional over-mold in phantom.

[0058] FIG. 41 is an enlarged and partial side elevational view of the assembly of FIG. 38 with the optional over-mold shown in phantom and the spacer shown under operative compression.

[0059] FIG. 42 is a partial side elevational view of the assembly of FIG. 38 with the optional over-mold shown in phantom and differential displacement in a cephalad direction in response to spinal distraction or tension.

[0060] FIG. 43 is a side elevational view of the assembly of FIG. 38 with the optional over-mold shown in phantom and shown in compression and operatively responding to spinal extension or lordosis.

[0061] FIG. 44 is an enlarged side elevational view of the assembly of FIG. 38 with the optional over-mold shown in phantom and shown operatively responding to spinal distraction as well as flexion.

[0062] FIG. 45 is an enlarged side elevational view of a third embodiment of a dynamic connecting member assembly according to the invention.

[0063] FIG. 46 is a reduced and partial exploded perspective view of the assembly of FIG. 45.

[0064] FIG. 47 is an enlarged and partial cross sectional view taken along the line 47-47 of FIG. 45 with an optional over-mold shown in phantom.

DETAILED DESCRIPTION OF THE INVENTION

[0065] As required, detailed embodiments of the present invention are disclosed herein; however, it is to be understood that the disclosed embodiments are merely exemplary of the invention, which may be embodied in various forms. Therefore, specific structural and functional details disclosed herein are not to be interpreted as limiting, but merely as a basis for the claims and as a representative basis for teaching one skilled in the art to variously employ the present invention in virtually any appropriately detailed structure. It is also noted that any reference to the words top, bottom, up and down, and the like, in this application refers to the alignment shown in the various drawings, as well as the normal connotations applied to such devices, and is not intended to restrict positioning of the connecting member assemblies of the application and cooperating bone anchors in actual use.

[0066] With reference to FIGS. 1-37, the reference numeral 1 generally designates a non-fusion dynamic stabilization longitudinal connecting member assembly according to the present invention. The connecting member assembly 1 includes an inelastic anchor member, generally 4, having an inelastic elongate inner core 6 extending from a bone anchor attachment portion 8; a first elastic differential compression spacer 10; a first hard or inelastic contoured pressure washer 11; a first inelastic sleeve or sleeve trolley 12; a second inelastic contoured pressure washer 13; a second elastic differential compression spacer or elastic bumper 14; a third inelastic contoured pressure washer 15; a second inelastic sleeve 16; a third elastic differential compression spacer or elastic bumper 18; and an inelastic crimping ring 20; all substantially symmetrically aligned with respect to a central axis A of the anchor member 4. The elongate core 6 of the anchor member 4 is receivable within the spacers, sleeves, pressure washers, bumper and crimping ring. Thus, the axis A of the anchor member 4 is also the axis of the fully assembled assembly 1. An optional over-molded sleeve or casing 22 can surround a portion of the anchor member 4 extending to the bone anchor attaching portion 8, the spacer 10, the washer 11 and a portion of the sleeve 12. A second over-molded sleeve or casing 23 surrounds a portion of the sleeve 12, the washer 13, the spacer 14, the washer 15 and a portion of the sleeve 16. As will be described in greater detail below, when fully assembled and all components fixed in position, as shown in FIGS. 1, 2 and 4, for example, the spacers 10 and 14 and the bumper 18 are in compression, with the more elastic bumper 18 shown being slightly deformed and bulging outwardly due to the compressive force placed thereupon. The pre-compressed spacers and bumpers in turn place axial forces upon the sleeves 12 and 16, the sleeves thus being in a dynamic relationship with the spacers and movable with respect to the core. In particular, FIG. 2 illustrates placement of the assembly 1 and cooperating bone screws as posi-

tioned along a human spine with the elastic bumper **18** being at a top or upper position, the bumper **18** and spacers **10** and **14** having varying elasticities to allow for more movement of the assembly **1** in a cephalad or cranial direction and more limited movement in a caudad direction.

[0067] As illustrated in FIG. 2, the dynamic connecting member assembly **1** cooperates with at least three bone anchors and is illustrated with four bone anchors in the form of polyaxial bone screws, generally **25**, the assembly **1** being captured and fixed in place at the anchor portion **8**, the inelastic sleeve **12** and the inelastic sleeve **16** by the bone screws **25**. Because the anchor portion **8** and the sleeves **12** and **16** have substantially solid, substantially hard, inelastic cylindrical surfaces, the connecting member assembly **1** may be used with a wide variety of bone screws and other bone anchors already available for cooperation with more rigid rods including fixed, monoaxial bone screws, hinged bone screws, polyaxial bone screws, and bone hooks and the like, with or without compression inserts, that may in turn cooperate with a variety of closure structures having threads, flanges, or other structure for fixing the closure structure to the bone anchor, and may include other features, for example, external or internal drives, break-off tops and inner set screws. The bone anchors, closure structures and the connecting member assembly **1** are then operably incorporated in an overall spinal implant system for correcting degenerative conditions, deformities, injuries, or defects to the spinal column of a patient.

[0068] In the particular embodiment of the assembly **1** being illustrated herein, wherein the sleeves **12** and **16** are advantageously relatively thin so as to result in an assembly having a low profile, the bone screws **25** are equipped with upper and lower pressure inserts to closely hold the sleeves and yet not crush the sleeves against the inner core **6**. In particular, with reference to FIGS. 29, 30 and 31, the illustrated polyaxial screws **25** each include a shank **27**, a receiver or head **28**, a lower pressure insert **29**, an upper pressure insert **30** and a closure structure, generally **32** that further includes an outer fastener **33** and an inner set screw **34**. The illustrated shank **27** for insertion into a vertebra (not shown) is pivotally attached to the open receiver or head **28**. The shank **27** includes a threaded outer surface and optionally includes a central cannula or through-bore disposed along an axis of rotation of the shank **27**. The through bore provides a passage through the shank interior for a length of wire or pin inserted into the vertebra prior to the insertion of the shank **27**, the wire or pin providing a guide for insertion of the shank **27** into the vertebra. The receiver **28** includes a pair of spaced and generally parallel arms that form an open generally U-shaped channel therebetween that is open at distal ends of such arms. The receiver arms each include radially inward or interior surfaces that have a discontinuous guide and advancement structure mateable with cooperating structure on the outer fastener **33**. The guide and advancement structure may be a partial helically wound flangeform configured to mate under rotation with a similar structure on the outer fastener **33** or a buttress thread, a square thread, a reverse angle thread or other thread like or non-thread like helically wound advancement structures for operably guiding under rotation and advancing the fastener **33** downward between the receiver arms and having such a nature as to resist splaying of the receiver arms when the fastener **33** is advanced between the receiver arms.

[0069] The illustrated shank **27** is top loaded into the receiver **28** and has a curved head for sliding, pivotal engagement with an inner surface of the receiver **28**. However, a

variety of polyaxial connections may be possible. For example, a spline capture connection as described in U.S. Pat. No. 6,716,214, and incorporated by reference herein, may be used wherein the bone screw shank includes a capture structure mateable with a retaining structure disposed within the receiver. The retaining structure includes a partially spherical surface that is slidably mateable with a cooperating inner surface of the receiver, allowing for a wide range of pivotal movement between the shank **27** and the receiver **28**. Polyaxial bone screws with other types of capture connections may also be used according to the invention, including but not limited to, threaded connections, frictional connections utilizing frusto-conical or polyhedral capture structures, integral top or downloadable shanks, and the like. Also, as indicated above, polyaxial and other bone screws for use with connecting members of the invention may have bone screw shanks that attach directly to the connecting member or may include compression members or inserts, such as the members **29** and **30** that engage the bone screw shank and cooperate with the shank, the receiver and the closure structure to secure the connecting member assembly to the bone screw and/or fix the bone screw shank at a desired angle with respect to the bone screw receiver that holds the longitudinal connecting member assembly. Furthermore, although the closure structure **32** of the present invention is illustrated with the polyaxial bone screw **25** having an open receiver or head **28**, it foresees that a variety of closure structures may be used in conjunction with any type of medical implant having an open or closed head or receiver, including monoaxial bone screws, hinged bone screws, hooks and the like used in spinal surgery.

[0070] To provide a biologically active interface with the bone, the threaded shank **27** may be coated, perforated, made porous or otherwise treated. The treatment may include, but is not limited to a plasma spray coating or other type of coating of a metal or, for example, a calcium phosphate; or a roughening, perforation or indentation in the shank surface, such as by sputtering, sand blasting or acid etching, that allows for bony ingrowth or ongrowth. Certain metal coatings act as a scaffold for bone ingrowth. Bio-ceramic calcium phosphate coatings include, but are not limited to: alpha-tri-calcium phosphate and beta-tri-calcium phosphate ($\text{Ca}_3(\text{PO}_4)_2$), tetra-calcium phosphate ($\text{Ca}_4\text{P}_2\text{O}_9$), amorphous calcium phosphate and hydroxyapatite ($\text{Ca}_{10}(\text{PO}_4)_6(\text{OH})_2$). Coating with hydroxyapatite, for example, is desirable as hydroxyapatite is chemically similar to bone with respect to mineral content and has been identified as being bioactive and thus not only supportive of bone ingrowth, but actively taking part in bone bonding. It is also foreseen that combinations of the above can be used, such as a composite of titanium plasma spray and hydroxyapatite.

[0071] The closure structure **32** can be any of a variety of different types of closure structures for use in conjunction with the present invention with suitable mating structure on the interior surface of the upstanding arms of the receiver **28**. The illustrated closure structure **27** is in two pieces with the outer fastener **33** rotatable between the spaced arms and the inner set screw **34** rotatable within the outer fastener **33**. However, single piece closures may be used and other structures, such as slide-in closure structures may be used as an alternative to helically wound closures. The illustrated outer fastener **33** is substantially cylindrical and includes an outer helically wound guide and advancement structure in the form of a flange form that may take a variety of forms, including those described in Applicant's U.S. Pat. No. 6,726,689, which

is incorporated herein by reference. It is also foreseen that according to the invention the closure structure guide and advancement structure could alternatively be a buttress thread, a square thread, a reverse angle thread or other thread like or non-thread like helically wound advancement structure for operably guiding under rotation and advancing the closure structure downward between the receiver arms and having such a nature as to resist splaying of the arms when the closure structure is advanced into the U-shaped channel formed by the arms. The illustrated closure 32 further includes the inner set screw 34 with an internal drive in the form of an aperture utilized for assembly of the set screw and removal of the entire closure 32. It is foreseen that the closure structure may alternatively include an external drive, such as a break-off head designed to allow such a head to break from a base of the closure at a preselected torque, for example, 60 to 120 inch pounds. Such a closure structure would also include a base having an internal drive to be used for closure removal.

[0072] Returning to the longitudinal connecting member assembly 1 illustrated in FIGS. 1-37, the assembly 1 is elongate, with the inner core 6 being a substantially solid, smooth and in the form of a uniform cylinder or rod having an outer cylindrical surface 36 and a substantially circular cross-section. The core 6 and integral anchor attachment portion 8 may be made from metal, metal alloys or other suitable materials, including plastic polymers such as polyetheretherketone (PEEK), ultra-high-molecular weight-polyethylene (UHMWP), polyurethanes and composites, including composites containing carbon fiber and layers of different materials. It is noted that although an anchor member 4 is illustrated in which the components 6 and 8 are integral, the core 6 and the anchor attachment portion 8 may be made from different materials, for example, the core 6 may be made out of PEEK and inserted into and fixed and/or adhered to a bone anchor attachment portion 8 made out of titanium. The core 6 and attachment portion 8 may include a small central lumen or through-bore (not shown) extending along the central axis A. Such a lumen may be used as a passage through the entire assembly 1 interior for a length of a guide wire for aiding insertion of the assembly 1 between implanted bone screws 25 in a percutaneous or less invasive procedure.

[0073] With particular reference to FIGS. 3 and 5, the anchor member 4 is substantially cylindrical along an entire length thereof along the axis A and includes at least two or more circular cross-sections along the length thereof. The illustrated member 4 includes the slender and thus more flexible core 6 of a first circular cross-section and the bone anchor attachment portion 8 that has a second circular cross-section that is larger than the core 6 cross-section and thus is more rigid than the core 6. The core 6 terminates at an end 38. Prior to final assembly by the vendor or manufacturer, the core 6 is typically of a length greater than that shown in the drawing figures so that the core 6 may be grasped by a tool (not shown) near the end 38 and pulled along the axis A in a direction away from the anchor attachment portion 8, in certain embodiments, tensioning the core 6 and putting compressive forces on the spacers and bumper, as will be described in greater detail below. Between the core 6 and the portion 8 is a buttress plate or annular enlargement 40 that has a third circular cross-section that is larger than the attachment portion 8 cross-section. The buttress plate 40 is integral with and disposed between the core 6 and the portion 8. Although the illustrated anchor member 4 is substantially cylindrical, it is foreseen

that the core 6, the portion 8 and the plate 40 may have other forms, including but not limited to oval, square and rectangular cross-sections as well as other curved or polygonal shapes. The bone anchor attachment portion 8 is of a length along the axis A for cooperating with at least one and up to a plurality of bone attachment members, such as the bone screws 25, hooks or other types of bone anchors. The portion 8 is substantially solid and rigid, with an outer cylindrical surface 39 that terminates at an end 41. The plate 40 includes a first substantially flat and annular face 42 facing away from the core 6 and an opposed face 44 facing toward the core 6. The faces 42 and 44 extend radially from the axis A. An outer cylindrical surface 46 extends between the faces 42 and 44. A gently sloping transition surface or flange 48 bridges between and connects the outer cylindrical surface 36 of the core 6 with the substantially flat facing face 44 of the buttress plate 40.

[0074] With particular reference to FIGS. 13-15 and 19-22, the sleeves 12 and 16 are each sized and shaped to be slidably received over the core 6 along the axis A and each have a length measured along the axis A that is sufficient for the attachment of at least one bone screw 25 thereon. Similar to the inelastic anchor member 4, the inelastic sleeves 12 and 16 may be made from metal, metal alloys or other suitable materials, including plastic polymers such as polyetheretherketone (PEEK), ultra-high-molecular weight-polyethylene (UHMWP), polyurethanes and composites, including composites containing carbon fiber. The sleeves 12 and 16 may be made of the same material as the cooperating core 6, for example, the anchor member 4 and the sleeves 12 and 16 may all be made from PEEK; or, for example, the core 6 may be made from one material, such as PEEK, while the sleeves 12 and 16 may be made from another material, such as a metal (e.g. stainless steel or titanium). In order to have low or no wear debris, the sleeve 12 and 16 inner surfaces and/or cooperating core 6 outer surfaces may be coated with an ultra thin, ultra hard, ultra slick and ultra smooth coating, such as may be obtained from ion bonding techniques and/or other gas or chemical treatments.

[0075] The illustrated sleeves 12 and 16 each are substantially cylindrical, having outer cylindrical bone anchor attachment surfaces 50 and 52, respectively, that are each of substantially the same diameter as the outer surface 39 of the bone anchor attachment portion 8. Each of the sleeves 12 and 16 further include a substantially cylindrical inner surface 54 and 56, respectively, that define a through-bore for the passage of the core 6 therethrough. While the surface 56 is shown as being cylindrical, the illustrated surface 54 of the sleeve 12 is preferably curved and shown as slightly hour-glass or hyperboloid-like in configuration running along the axis A, and/or at least has non-linear relief at one or both ends. The slightly curved surface 54 results in at least a partially non-linear inner lumen that decreases both bending stresses along the core 6 and wear debris between the parts. For example, if the core 6 is flexed, the inner surface 54 allows deformation of the core over a longer area or length resulting in reduced stresses and a longer fatigue life. Furthermore, if the core 6 is made from a material such as PEEK, the curved surface 54 and/or end surface non-linear relief reduces contact wear and bending stresses along the core 6 surface that is received in the sleeve 12. The sleeve 12 includes a pair of opposed end plates 58 and 60 and the sleeve 16 includes a pair of opposed end plates 62 and 63. The illustrated plates 58, 60, 62 and 63 have outer cylindrical surfaces 64, 66, 68 and 69, respectively, that

are of substantially the same diameter as the buttress plate outer cylindrical surface 46. The sleeve 12 includes opposed curved and slightly concave flanged end surfaces 70 and 72, each running from the inner surface 54 radially outwardly toward respective cylindrical surfaces 64 and 66. The illustrated concave surfaces 70 and 72 are partially spherical. The sleeve 16 includes one concave end surface 74 and an opposed planar end surface 76. The illustrated surface 74 is partially spherical.

[0076] With reference to FIGS. 6-9, 16-18 and 23-25, the elastic spacers 10 and 14 and the elastic bumper 18 are sized and shaped to be slidingly received over the core 6 and may be made from a variety of elastic materials of different durometers and materials, including, but not limited to natural or synthetic elastomers such as polyisoprene (natural rubber), and synthetic polymers, copolymers, and thermoplastic elastomers, for example, polyurethane elastomers such as polycarbonate-urethane elastomers. In order to have low or no wear debris, the spacers 10 and 14 and bumper 18 inner and side surfaces may also be coated with an ultra thin, ultra hard, ultra slick and ultra smooth coating, such as may be obtained from ion bonding techniques and/or other gas or chemical treatments.

[0077] The illustrated spacers 10 and 14 advantageously cooperate with the core 6 of the anchor member 4, providing directed axial movement, limitation and protection of movement by the sleeves 12 and 16 along the core 6 located between bone screws 25. With particular reference to FIGS. 6-9 and 16-18, the illustrated spacers 10 and 14 are substantially similar in geometry, differing only with regard to inner surfaces that define through bores for receiving the anchor member core 6 and number of optional outer grooves. Each of the spacers 10 and 14 have an external substantially cylindrical outer surface 78 and 80, respectively, and internal surfaces 82 and 84, respectively, each defining through bores. The internal surface 82 is further defined by a flared or conical outwardly extending surface 86 sized and shaped for cooperating with the transition surface 48 of the anchor member 4. The spacer 10 includes opposed substantially planar and annular end surfaces 88 and 89 and the spacer 14 includes opposed substantially planar and annular end surfaces 90 and 91. When cooperating with the core 6, the end surfaces 88 and 89 and 90 and 91 are substantially perpendicular to the axis A. It is foreseen that in some embodiments, the spacers 10 and 14 may be of circular, square, rectangular or other cross-section including curved or polygonal shapes. In the illustrated embodiment, both the spacers 10 and 14 further include optional compression grooves, the spacer 10 having a single groove 93 and the spacer 14 having a pair of grooves 94 and 95. Spacers according to the invention may include one, none or any desired number of grooves that allow for some additional compression of the spacers 10 and 14 when pressed upon in an axial direction between the bone anchor attachment portion 8 and the cooperating sleeves 12 and 16. The illustrated groove 93 and groove pair 94 and 95 are substantially uniform and circular in cross-section, being formed in the respective external surfaces 78 and 80 and extending radially toward respective internal surfaces 82 and 84. The size of the internal surfaces 82 and 84 allow for some axially directed sliding movement of the respective spacers 10 and 14 with respect to the core surface 36. The illustrated spacer 14 is more elastic than the spacer 10, both with respect to geometry, by having more grooves than the spacer 10 and also may be made from a material with greater elasticity (lower durom-

eter) than the spacer 14, resulting in an assembly that advantageously provides for greater travel of the assembly in a cephalad direction, if desired.

[0078] With particular reference to FIGS. 10-12, the domed articulating wear or pressure washer 11 is shown. With reference to FIG. 3, for example, it is noted that the pressure washers 13 and 15 are identical to the illustrated pressure washer 11, thus the discussion herein of the pressure washer 11 also applies to the washers 13 and 15. The pressure washer 11 has an external substantially cylindrical outer surface 98 and internal substantially cylindrical surface 100, defining a through bore sized and shaped to receive the core 6. The washer 11 further includes a substantially planar end surface 102 and an opposed, curved, convex surface 104 sized and shaped for cooperation with a substantially concave surface of a cooperating sleeve, such as the surface 70, surface 72 or the surface 74. The illustrated convex surface 104 is at least partially spherical. When cooperating with the core 6, the end surface 102 is substantially perpendicular to the axis A. The size of the internal surface 100 allows for some axially directed sliding movement of the washer 11 with respect to the core surface 36. The washer 11 is preferably made from a firm material, such as metal and metal alloys with titanium being particularly preferred; or other suitable materials, including plastic polymers such as polyetheretherketone (PEEK), ultra-high-molecular weight-polyethylene (UHMWPE), polyurethanes and composites, including composites containing carbon fiber. In order to reduce wear debris, the washers 11, 13 and 15 are preferably made from a material different than the cooperating sleeves 12 and 16. For example, the sleeves 12 and 16 may be made of a titanium alloy while the washers 11, 13 and 15 may be made from a high molecular weight polyethylene. With particular reference to the washer 11 and as shown in FIG. 4, with the convex surface 104 slidingly engaging the concave surface 72 of the sleeve 12, the pressure washer 11 advantageously allows for tilt, slide and rotation of the washers along the core 6 and with respect to the sleeve 12, maintaining substantially full contact between the washer 11 and the sleeve 12, resulting in better load distribution along the assembly 1, keeping stresses on the inside of the tubular sleeve 12, rather than on an outer surface or end, and thus allowing for better angulation, translation and compression of the entire assembly 1, as each of the pressure washers 11, 13 and 15 have curved, convex surfaces fully contacting and cooperating with substantially similarly curved concave inner surfaces of the sleeves 12 and 16. Thus, the core 6, cooperating compressible spacers 10 and 14, sleeves 12 and 16 and washers 11, 13 and 15 allow for some twist or turn, providing some relief for torsional stresses.

[0079] The over-molded coverings 22 and 23 are preferably thin, soft and elastic, primarily provide protection to the body by keeping wear debris within the assembly 1 and keeping scar tissue out of the assembly 1 at the juncture between the spacers, washers and sleeves. Particularly when the assembly 1 is placed in tension as shown in FIG. 33, the over-molded sections 22 and 23 provide a covering over the components that may separate, for example, the pressure washer 11 and the sleeve 12, guarding against gaps that might otherwise irritate scar and surrounding body tissue. The over-molded sections 22 and 23 may be made of a variety of materials including natural and synthetic plastics and composites. The illustrated over-molds 22 and 23 are a molded thermoplastic elastomer, for example, polyurethane or a polyurethane blend; however, any suitable polymer material may be used.

[0080] The illustrated over-mold 22 is fabricated around and about the surfaces 42 and 46 of the anchor plate 40, the entire spacer 10, the entire washer 11 and the entire end plate 60 of the sleeve 12. The illustrated over-mold 23 is fabricated around and about the surfaces of the end plate 58 of the sleeve 12, the entire washer 13, the entire spacer 14, the entire washer 15 and the entire end plate 63 of the sleeve 16. The over-molds 22 and 23 are fabricated from an initially flowing elastomer, as will be described more fully below, with the elastomer engaging and possibly adhering to the surfaces of the sleeves, washers and spacers being covered thereby. Each formed elastomer is substantially cylindrical, but thin so as to also be flexible and deformable when the assembly 1 is bent, compressed or stretched as shown in the drawing figures. In both spinal flexion and extension, the over-molds 22 and 23 completely surround or cover the assembly 1 components as also illustrated in the drawing figures. It is foreseen that the material for the over-molds 22 and 23 may be sized and made from such materials so as to provide for relatively more or less bendability, as well as compressibility and stretchability.

[0081] With particular reference to FIGS. 23-25, the elastic bumper 18 is substantially cylindrical, including an outer surface 108 and an inner surface 109 forming a substantially cylindrical through bore that opens at planar end surfaces 110 and 111 and operatively extends along the axis A. The bumper 18 may further include a compression groove or grooves similar in form and function to the compression grooves 93, 94 and 95 described above with respect to the spacers 10 and 14. The bumper 18 is sized and shaped to slidably receive the core 6 through the inner surface 109. The bumper 18 is preferably made from an elastomeric material such as polyurethane, but may be made from any suitable elastomeric material. The bumper 18 is typically more elastic than either of the spacers 10 and 14, providing greater movement of the sleeve 16 in a direction toward the bumper 18 than toward the spacer 14.

[0082] With particular reference to FIGS. 26-28, the crimping ring 20 is substantially cylindrical and includes an outer surface 120 and an inner surface 122 forming a substantially cylindrical through bore that opens at planar end surfaces 124 and 126 and operatively extends along the axis A. The crimping ring 20 is sized and shaped to receive the elongate core 6 through the inner surface 122. The crimping ring 20 further includes a pair of opposed crimp or compression grooves 130 that are pressable and deformable inwardly toward the axis A upon pre-compression of the spacers 10 and 14 and the bumper 18 during assembly of the assembly 1. The crimping ring 20 is preferably made from a stiff, but deformable material, including metals and metal alloys. As an alternative to the grooves 130, in certain embodiments of the invention, the crimp ring 20 may include an inner helical thread (not shown) with the core 6 having a mating helical outer thread (not shown), for fixing the ring 20 on the core 6 and compressing the spacers 10 and 14 and bumper 18 to a desired degree.

[0083] The illustrated dynamic connecting member assembly 1 having pre-compressed spacers is shown cooperating with four polyaxial bone screws 25 as shown in FIG. 2. In use, the bone screws 25 are implanted into vertebrae (not shown). Each vertebra may be pre-drilled to minimize stressing the bone. Furthermore, when a cannulated bone screw shank is utilized, each vertebra will have a guide wire or pin inserted therein that is shaped for the bone screw cannula of the bone screw shank 27 and provides a guide for the placement and angle of the shank 27 with respect to the cooperating vertebra.

A further tap hole may be made and the shank 27 is then driven into the vertebra by rotation of a driving tool (not shown) that engages a driving feature on or near a top portion of the shank 27. It is foreseen that both the screws 25 and the longitudinal connecting member assembly 1 may be inserted in a conventional, percutaneous or other minimally invasive surgical manner.

[0084] With particular reference to FIGS. 1-4, the longitudinal connecting member assembly 1 is assembled to provide pre-compressed spacers 10 and 14 and bumper 18 prior to implanting the assembly 1 in a patient. FIGS. 1, 2 and 4 illustrated the pre-compressed, ready to use assembly 1, while FIG. 32 illustrates the assembly 1 during spinal movement that results in further compression of the spacers 10 and 14, while FIG. 33 illustrates the assembly 1 during spinal movement that results in further compression of the bumper 18 and extension of the assembly 1 at the spacers 10 and 14. With particular reference to FIG. 3, the assembly 1 is assembled by first providing the anchor member 4 that has a core 6 that is longer in the axial direction A than the core 6 illustrated in the drawing figures. The spacer 10 is first loaded onto the core 6 by inserting the core 6 end 38 into the bore defined by the inner surface 82 with the face 89 directed toward the buttress plate 40. The spacer 10 is moved along the core 6 until the surface 86 contacts the surface 48. The pressure washer 11 is then threaded on the core 6 with the face 102 facing the end surface 88 of the spacer 10. The sleeve 12 is then threaded onto the core 6 with the concave face 72 of the plate 60 facing the convex surface 104 of the pressure washer 11. The core 6 is then received in the bore of the pressure washer 13, with the convex face of the washer 13 facing the concave face 70 of the sleeve 12. The spacer 14 is thereafter loaded onto the core 6 by inserting the core 6 end 38 into the bore defined by the inner surface 84 with the face 91 facing the toward the pressure washer 13. The spacer 14 is moved along the core 6 until the spacer 14 contacts the pressure washer 13. The pressure washer 15 is then threaded on the core with a planar face thereof facing the planar face 90 of the spacer 14. The sleeve 16 is then threaded onto the core 6 with the concave face 74 facing the convex end surface of the pressure washer 15. The core 6 is received in the bore defined by the inner cylindrical surface 56 and the sleeve 16 is moved along the core 6 until the sleeve 16 abuts the pressure washer 15. The bumper 18 is thereafter loaded onto the core 6 by inserting the core 6 end 38 into the bore defined by the inner surface 109 with the face 111 facing the toward the planar end surface 76 of the sleeve 16. The bumper 18 is moved along the core 6 until the surface 111 contacts the surface 76. The crimping ring 20 is thereafter loaded onto the core 6 by inserting the core 6 end 38 into the bore defined by the inner surface 122 with the face 126 facing the toward the surface 110 of the bumper 18. The crimping ring 20 is moved along the core 6 until the surface 126 contacts the surface 110. It is noted that due to the symmetrical nature of the sleeve 12, the spacer 14, the bumper 18 and the crimping ring 20, these components may be loaded onto the core 6 from either side thereof.

[0085] After the crimping ring 20 is loaded onto the core 6, manipulation tools (not shown) are used to grasp the core 6 near the end 38 and at the bone anchor attachment portion 8, placing some tension on the core 6. The spacer 10, the sleeve 12, the spacer 14, the sleeve 16, the bumper 18 and the crimping ring 20 are moved toward the buttress plate 40 and into contact with one another. A desired amount of axial

compressive force is placed on the components loaded on the core 6, followed by deforming the crimping ring at the crimp grooves 120 and against the core 6. When the manipulation tools are released, the crimping ring 20, now firmly and fixedly attached to the core 6 holds the spacers 10 and 14 and the bumper 18 in compression and the spacers and bumper place axial tension forces on the core 6, resulting in a dynamic relationship between the core 6 and the spacers 10, 14 and the bumper 18. The spacers 10 and 16 are slidable with respect to the core 6, but also are limited by the buttress plate of the anchor member 4 and end plates of the sleeves 12 and 16. Furthermore, the bumper 18 that is compressed between the sleeve surface 76 and the crimping ring surface 116 is also slidable with respect to the core 6. The spacers 10 and 14 and the bumper 18 place a distractive force on the core 6 along the axis A and between the buttress plate 40 and the crimping ring 20, but also are movable with respect to the core 6, thus being able to respond to jolting and other body movements and thereafter spring back into an originally set location. The sleeves 12 and 16 that may compress slightly, but are more rigid than the spacers 10 and 14, keep the spacers 10 and 14 in an approximate desired axially spaced relation. However, the spacers 10 and 14 also advantageously slide along the core 6 in response to outside forces. The core 6 is then trimmed to be approximately flush with the end surface 114 of the crimping ring 20.

[0086] It is noted that mechanical characteristics of the assembly components, such as creep, may require the spacers 10 and 14 and the bumper 18 to be compressed at a higher load and then allowed to reach a steady state before placement and molding of the over-mold coverings 22 and 23 and eventual operative use with the bone screws 25. The over-molds 22 and 23 are fabricated by first placing the anchor portion 8 and/or the sleeves 12 or 16 in a jig or other holding mechanism such that the jig frictionally engages such portion 8 and/or sleeves 12 and 16, followed by fabricating the over-mold 22 about and between the plate 40, the spacer 10, the pressure washer 11 and an end portion of the sleeve 12 and the over-mold 23 about and between an opposite end portion of the sleeve 12, the washer 13, the spacer 14, the washer 15 and an end portion of the sleeve 16 as best shown in phantom in FIG. 4. In a preferred method of fabrication of the over-molds 22 and 23, an elastic, polymeric material flows about the desired components of the assembly 1 at room temperature, followed by a vacuum cure. It is noted that in some embodiments of the invention, the over-molds 22 and 23 may be fabricated about the desired assembly 1 components prior to compression of the spacers 10 and 14 and the bumper 18. In other embodiments, the over-molds 22 and 23 may be fabricated about the spacers 10 and 14 after an initial compression of the spacers, followed by a final compression step after cure of the over-molds.

[0087] With reference to FIGS. 2 and 29-37, the assembly 1 is eventually positioned in an open or percutaneous manner in cooperation with the bone screws 25 with the over-molds 22 and 23 disposed between bone screws 25, with a bone screw attached to each of the sleeves 12 and 16 and, as illustrated, two bone screws 25 attached to the anchor portion 8. A closure structure 32 is used to attach each screw 25 to the assembly 1 with the sleeves 12 and 16 and the anchor portion 8 each being cradled between a lower pressure insert 29 and an upper pressure insert 30.

[0088] With particular reference to FIGS. 2, 32-33, a desired placement of the assembly 1 is shown wherein an

arrow C indicates movement of the bone screws 25 attached to the sleeves 12 and 15 generally in a cephalad or cranial direction. Specifically, FIG. 2 illustrated a pre-compressed assembly 1 in a neutral position, FIG. 32 illustrates compression of the spacers 10,14 and FIG. 33 shows extension or tension of the assembly at spacers 10,14 and movement of the sleeves 12 and 16 in a cephalad direction (arrow c). FIGS. 32-33 illustrate how the assembly 1 allows greater movement of the sleeves and thus the bone screws 25 and attached spinal segments in the cephalad direction than in the caudad direction, the elastic bumper 18 being the most compressible component of the assembly 1 and the spacer 14 being more elastic and thus more compressible than the spacer 10 due to the geometry thereof (e.g., an extra groove in the spacer 14). In other embodiments of the invention, the spacer 14 may be made from a material of different durometer than the spacer 10, to allow for a desirable increased upward or cephalad movement of a portion of the assembly 10.

[0089] With reference to FIGS. 34 and 35, supported spinal extension as well as movement in the cephalad direction C is also possible with the assembly 1. The washers 11, 13 and 15 are slidable and rotatable with respect to the cooperating sleeves 12 and 16, advantageously providing steady, balanced and controlled load distribution during angulation, both spinal extension and flexion as well as during compression and tension. Furthermore, the washers 11, 13, and 15 and sleeves 12 and 16 cooperate with the spacers 10 and 14 to aid in bending and tilting of the assembly 1, supporting and controlling the spine in response to lordosis and kyphosis, for example, and also providing for rotation and tilting of the assembly in both coronal and sagittal planes, supporting and controlling the spine in the case of scoliosis as shown in FIGS. 36 and 37. Thus, once attached to the bone screws 25, the assembly 1 is substantially dynamically loaded and oriented relative to the cooperating vertebra, providing relief (e.g., shock absorption) and protected movement with respect to not only flexion and extension, but also to distractive, compressive, torsional and shear forces placed on assembly 1 and bone screws 25.

[0090] If removal of the assembly 1 from any of the bone screw assemblies 25 is necessary, or if it is desired to release the assembly 1 at a particular location, disassembly is accomplished by using a driving tool (not shown) with a driving formation cooperating with the closure structure 32 to rotate and remove the closure structure from the receiver 28. Disassembly is then accomplished in reverse order to the procedure described previously herein for assembly.

[0091] Eventually, if the spine requires more rigid support, the connecting member assembly 1 according to the invention may be removed and replaced with another longitudinal connecting member, such as a solid rod, having the same diameter as the rod portions 8, utilizing the same bone screw 25 components. Alternatively, if less support is eventually required, a less rigid, more flexible assembly, for example, an assembly 1 made with elastic spacers and bumper of different durometer or geometry may replace the assembly 1, also utilizing the same bone screws 25.

[0092] With reference to FIGS. 38-44, an alternative embodiment of a dynamic longitudinal connecting member, generally 201 is substantially similar to the assembly 1 with the exception that it is shorter than the assembly 1, cooperating with fewer bone screws along an elastic and more flexible portion thereof. Similar to the assembly 1, the assembly 201 provides for greater movement in the cephalad direction as

indicated by the arrow marked CC. The assembly 201 includes an anchor member, generally 204, having an elongate segment or inner core 206 and a bone anchor attachment portion 208; an elastic spacer 210; a pressure washer 211; a sleeve 216; an elastic bumper 218; and a crimping ring 220; all substantially symmetrically aligned with respect to a central axis AA of the anchor member 204. The elongate core 206 of the anchor member 204 is receivable within the spacer 210, the washer 211, the sleeve 216, the bumper 218 and the crimping ring 220. Thus, the axis AA of the anchor member 204 is also the axis of the fully assembled assembly 201. When fully assembled and fixed with all components fixed in position, the spacer 210 and the bumper 218 are placed in compression as shown in FIG. 40 and an elastic over-mold or covering 222 is applied about a buttress plate 240 of the anchor 204, the spacer 210, the washer 211 and a portion of the sleeve 212 (the covering 222 shown in phantom in FIG. 40) prior to attachment to three bone screws 25 as shown in FIG. 38.

[0093] In the illustrated embodiment, the anchor member 204 is substantially similar to the anchor member 4 previously described herein with respect to the assembly 1. Therefore, the member 204 includes the core 206, the bone anchor attachment portion 208 and the integral buttress plate 240 identical or substantially similar in size and shape to the respective core 6, attachment portion 8 and buttress plate 40 of the anchor member 4 previously described herein. The member 204 differs from the member 4 only in that the length of the core 206 is shorter than the core 6 as the core 206 holds only one sleeve 216, one cooperating spacer 210 and one washer 211 as compared to the core 6 that holds two sleeves, two spacers and three cooperating washers. The spacer 210 is identical or substantially similar to the spacer 10 previously described herein. The sleeve 216 is identical or substantially similar to the sleeve 16, having a concave end surface 274 identical or substantially similar to the concave end surface 74 of the sleeve 16 previously described herein. The washer 211 is identical or substantially similar to the washer 11 previously described herein, having a substantially convex end surface 304 identical or substantially similar to the end surface 104 of the washer 11. The surface 304 is slidably engageable with the concave surface 274 of the sleeve 216 such that a full and even surface contact occurs between the sleeve 216 and the washer 211, providing better load distribution along the assembly 201, keeping stresses on the inside of the sleeve 216 rather than on an outer surface during angulation, translation and compression. The bumper 218 and the crimping ring 220 are identical or substantially similar to the respective bumper 18 and the crimping ring 20 previously described herein with respect to the assembly 1.

[0094] The assembly 201 is assembled in a manner substantially similar to the manner of assembly previously described herein with respect to the assembly 1, the assembly 201 however, does not include a second spacer or second sleeve. Therefore, the core 206 is first received within a through bore of the spacer 210, followed by the washer 211, then within an inner surface of the sleeve 216, followed by an inner through bore of the bumper 218 and then an inner through bore of the crimping ring 220. Similar to what has been described previously with respect to the assembly 1, the core 206 may initially be of a longer length measured along the axis AA than is shown in the drawing figures, allowing for a manipulation tool to grasp the core 206 near an end thereof that extends through the crimping ring bore. The spacer 210

and bumper 220 are compressed, followed by deformation of the crimping ring 220 against the core 206. Then, the covering 222 is fabricated about the plate 240, the spacer 210, the washer 211 and an end portion of the sleeve 216. The assembly is now in dynamic relationship with the spacer 210, washer 211, sleeve 216 and bumper 218 being slidable with respect to the core 206, the sleeve 216 being more readily movable in a direction toward the bumper 218 due to the greater elasticity of the bumper 218 as compared to the spacer 210.

[0095] The assembly 201 may then be implanted, cooperating with three bone screws 25 as illustrated in FIG. 38 and as previously described herein with respect to the assembly 1. Unlike the assembly 1 that provides for a more dynamic and flexible connection between three illustrated bone screws 25, the assembly 201 provides for dynamic stabilization between first and second bone screws 25 and a more rigid connection between the second bone screw 25 and a third bone screw 25 as both the second and third bone screws are attached to the rigid attachment portion 208.

[0096] FIGS. 41 and 42 illustrate a range of axial or spinal movement of the assembly in a cephalad direction as noted by the arrow CC. FIG. 41 shows the spacer 210 being compressed and thus the sleeve 216 and attached bone screw 25 moving in a caudal direction. FIG. 42 shows the bumper 218 in a fully compressed state with the sleeve 216 and attached bone screw 25 moving in a cephalad direction. As illustrated in FIG. 42, the optional over-mold 222 covers the portion of the assembly 201 that is being stretched and tensioned, covering a gap formed between the sleeve 216 and the pressure washer 211, protecting spinal tissue and retaining any wear debris within the assembly 201.

[0097] With reference to FIG. 43, the assembly 201 is shown in an angulated or bent position as it would be in response to spinal extension, for example. The load on the assembly 201 being stabilized by movement of the pressure washer 211 with respect to the sleeve 216 and also by partial compression of the spacer 210 along a groove thereof.

[0098] With reference to FIG. 44, the assembly 201 is shown in an angulated or bent position as it would be in response to spinal flexion, for example. The load on the assembly 201 is also distractive, causing a gap between the sleeve 216 and the pressure washer 211. The over-mold 222 advantageously stretches and prevents tissue from entering into the gap between the sleeve 216 and the washer 211.

[0099] With reference to FIGS. 45-47, an alternative embodiment of a dynamic longitudinal connecting member, generally 301 is substantially similar to the assembly 1 with the exception of some aspects of the geometry of the sleeve or tube trolley members, one of the spacers and two of the pressure washers located on either side of such spacer. Similar to the assembly 1, the assembly 301 provides for greater movement in the cephalad direction as indicated by the arrow marked CCC. The assembly 301 includes an anchor member, generally 304, having an elongate segment or inner core 306 and a bone anchor attachment portion 308; elastic spacers 310 and 314; pressure washers 311, 313 and 314; sleeves or tube trolleys 312 and 316; an elastic bumper 318; and a crimping ring 320, all substantially symmetrically aligned with respect to a central axis AAA of the anchor member 304. The elongate core 306 of the anchor member 304 is receivable within the spacers 310 and 314, the washers 311, 313 and 315, the sleeves 312 and 316, the bumper 318 and the crimping ring 320. Thus, the axis AAA of the anchor member 304 is also the

axis of the fully assembled assembly 301. When fully assembled and fixed with all components fixed in position, the spacers 310 and 314 and the bumper 318 are placed in compression as shown in FIG. 45 and an optional elastic over-mold or covering 322 is applied about a buttress plate 340 of the anchor 304, the spacer 310, the washer 311 and a portion of the sleeve 312 and an optional elastic over-mold or covering 323 is applied about a portion of the sleeve 312, the washer 313, the spacer 314, the washer 315 and a portion of the sleeve 316, both over-molds 322 and 323 molded over such component parts prior to attachment of the assembly 310 to three bone anchors such as the bone screws 25, in the same positions shown for the assembly 1 in FIG. 32, for example.

[0100] The anchor member 304, the spacer 310, the pressure washer 311, the sleeve 312, the bumper 318 and the crimping ring 320 are identical or substantially similar to the respective anchor member 4, spacer 10, pressure washer 11, sleeve 12, bumper 18 and crimping ring 20 of the assembly 1 and therefore shall not be discussed in great detail herein. The sleeve 312 has a curved inner surface 354 substantially similar to the curved inner surface 54 previously described herein with respect to the sleeve 12. The sleeve 316 has a curved inner surface 355 that is also substantially similar to the curved inner surface 54 previously described herein with respect to the sleeve 12. In substantially all other aspects of form and function, the sleeve 316 is substantially similar to the sleeve 16 previously described herein with respect to the assembly 1. The sleeve 312 includes a pair of opposed end plates 358 and 360 and the sleeve 316 includes a pair of opposed end plates 362 and 363. The illustrated plates 358, 360, 362 and 363 have outer cylindrical surfaces 364, 366, 368 and 369, respectively, that are substantially smaller in diameter than an outer diameter of the spacer 314 and the washers 313 and 315, allowing gaps for greater relative tilting or articulation of the sleeves 312 and 316 with respective adjacent washers 313 and 315, as will be described in greater detail below.

[0101] Thus, the assembly 301 primarily differs from the assembly 1 in the geometry of the washers 313 and 315 and the spacer 314. The elastic spacer 314 is substantially similar to the spacer 14 in form, function and materials with the exception that rather than having opposed planar side surfaces 90 and 91, the spacer 314 has opposed side surfaces 390 and 391 that are curved and concave. In particular, the illustrated surfaces 390 and 391 are cupped shaped, sized and shaped to closely slidingly mate with the dome shaped washers 313 and 315, as will be described in greater detail below, allowing for articulating movement between the spacer 314 and the washers 313 and 315, in addition to compression of the spacer 314.

[0102] The pressure washers 313 and 315 are identical to one another and also are substantially similar to the pressure washer 11 previously described above with the exception that the washers 313 and 315 have opposed, curved, convex side surfaces sized and shaped for cooperation with a substantially concave surface of a cooperating sleeve 312 or the concave surfaces 390 or 391 of the spacer 314. The illustrated washer 313 has opposed curved surfaces 402 and 404 and the washer 315 has opposed curved surfaces 402' and 404'.

[0103] The assembly 301 is assembled in a manner substantially similar to the manner of assembly previously described herein with respect to the assembly 1. Also, similar to what has been described previously with respect to the assembly 1, the core 306 may initially be of a longer length

measured along the axis AAA than is shown in the drawing figures, allowing for a manipulation tool to grasp the core 306 near an end thereof that extends through the crimping ring bore. The spacers 310 and 314 and the bumper 318 are compressed, followed by deformation of the crimping ring 320 against the core 306. Then, the coverings 322 and 323 are fabricated on the assembly 301 at the locations shown in the figures and as described above. The assembly 301 is now in dynamic relationship with the spacers 310 and 314, washers 311, 313 and 315, sleeves 312 and 316 and bumper 318 being slidable with respect to the core 306, both sleeves 312 and 316 being more readily movable in a direction toward the bumper 318 due to the greater elasticity of the bumper 318 as compared to the spacers 310 and 314.

[0104] The assembly 301 may then be implanted, cooperating with three bone screws 25 as previously illustrated with respect to the assembly 1. Like the assembly 1, the assembly 301 provides for a dynamic and flexible connection between three bone anchors. Furthermore, the double domed articulating wear washers 313 and 315 cooperating with the cupped spacer 314 allow for increased flexion and extension over the assembly 1 having the spacer 14 with planar surfaces. While the assembly 1 spacer 14, for example, elastically compresses when the assembly bends during spinal flexion or extension, the pressure washers 313 and 315 may slidingly articulate along the surfaces 390 and 391 of the spacer 314 during spinal flexion or extension. If compression accompanies the bending movement, the spacer 314 may also compress slightly in response to the spinal movement. As illustrated in FIG. 47, the end plates 358 and 360 of the sleeve 312 and the end plates 362 and 363 of the sleeve 316 are sized and shaped to have a smaller outer diameter than the pressure washers and spacers of the assembly 301 as well as provide a gap between such plates and adjacent components of the assembly 301, providing clearance for articulated movement between the components.

[0105] It is to be understood that while certain forms of the present invention have been illustrated and described herein, it is not to be limited to the specific forms or arrangement of parts described and shown.

What is claimed and desired to be secured by Letters Patent is as follows:

1. A longitudinal connecting member adapted for cooperation with a plurality of bone anchors implanted in a spine, the improvement wherein the longitudinal connecting member comprises:

- a) a substantially rigid anchor portion extending along a longitudinal axis of the connecting member, the anchor portion being formed of a first material and being directly engaged by first and second bone anchors;
- b) a core portion joined with an end of the anchor portion, extending along the longitudinal axis and indirectly engaged by a third bone anchor, the core portion being formed of a second material and having a reduced diameter relative to the anchor portion, wherein the second material and the reduced diameter cooperate so as to enable at least some flexing of the core portion;
- c) a first inelastic sleeve slidingly received over the core portion so as to be located between the third bone anchor and the core portion;
- c) a pair of elastic spacers received over the core portion such that each of the spacers is adjacent to an end of the first sleeve;

- d) a crimp ring engaging the core portion and being located so as to bias the spacers; and
 - e) an elastic over-mold surrounding the at least one of the spacers and a respective adjacent end of the first sleeve; wherein
 - f) the longitudinal connection member provides for greater movement in the cephalad direction than in the caudad direction.
- 2.** The improvement of claim **1**, wherein
- a) the elastic over-mold grips both the anchor portion and the first sleeve.
- 3.** The improvement of claim **1**, wherein
- a) the anchor portion includes has a first end plate and the elastic over-mold is molded about the first end plate.
- 4.** The improvement of claim **1**, wherein
- a) the elastic over-mold is made from a composite material comprising elongate reinforcement strands imbedded in a polymer.
- 5.** The improvement of claim **1**, wherein
- a) the core is made from a polymer.
- 6.** The improvement of claim **5**, wherein
- a) the polymer is polyetheretherketone.
- 7.** The improvement of claim **1**, wherein
- a) the first sleeve substantially blocks flexing of the portion of the core that is surrounded by the first sleeve.
- 8.** The improvement of claim **7**, wherein
- a) the core flexes primarily between the first sleeve and the anchor portion.
- 9.** The improvement of claim **1**, wherein the longitudinal connecting member further comprises:
- a) a second inelastic sleeve slidingly received over the core portion so as to be located between a fourth bone anchor and the core portion;
 - b) a third elastic spacer received over the core portion so as to be located between the second inelastic sleeve and the crimp ring; and
 - c) a second elastic over-mold surrounding a second end of the first sleeve, the third spacer and an adjacent end of the second sleeve.
- 10.** The improvement of claim **9**, wherein:
- a) the first sleeve substantially blocks flexing of the portion of the core that is surrounded by the first sleeve; and
 - b) the second sleeve substantially blocks flexing of the portion of the core that is surrounded by the second sleeve.
- 11.** The improvement of claim **10**, wherein
- a) the core flexes primarily:
 - i) between the first sleeve and the anchor portion; and
 - ii) between the first sleeve and the second sleeve.

* * * * *