

W. CLOSE.
 Improvement in Self-Acting Expansive Rail and Chair.
 No. 128,592. Patented July 2, 1872.

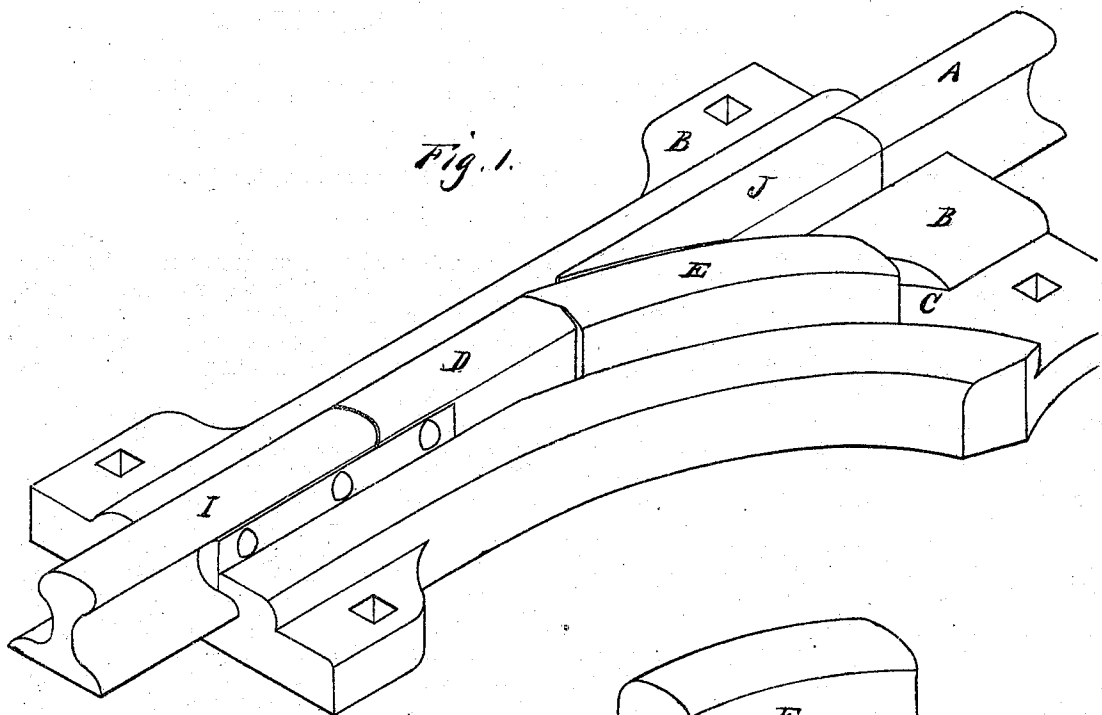

Fig. 1.

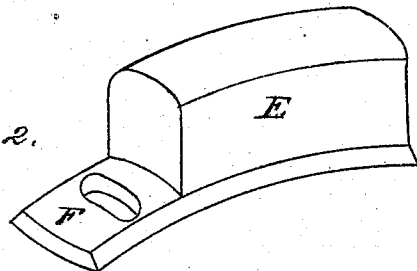

Fig. 2.

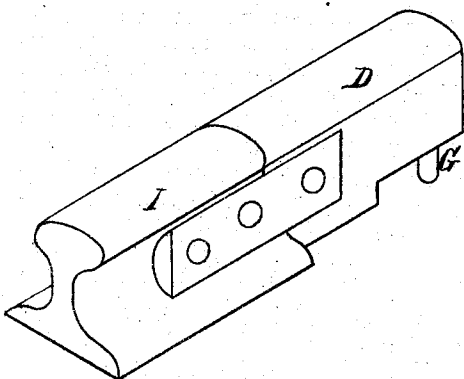
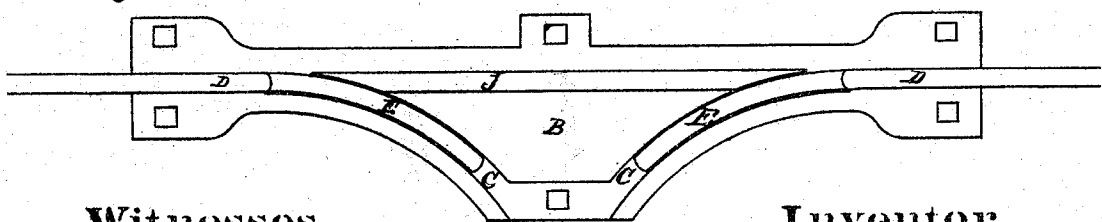

Fig. 3.



Witnesses
Geo. N. Strong
John L. Smith.

Inventor
William Close
 By his Attorneys
Smith & Strong.

UNITED STATES PATENT OFFICE.

WILLIAM CLOSE, OF SACRAMENTO, CALIFORNIA.

IMPROVEMENT IN SELF-ACTING EXPANSION RAILS AND CHAIRS.

Specification forming part of Letters Patent No. 128,592, dated July 2, 1872.

SPECIFICATION.

To all whom it may concern:

Be it known that I, WILLIAM CLOSE, of Sacramento, in the county of Sacramento and State of California, have invented a new and useful Self-Acting Expansion Rail and Chair; and I do hereby declare that the following is a full and exact description of the same, reference being had to the accompanying drawing and to the letters of reference marked thereon.

The object of my invention is to provide a self-acting expansion rail and chair, to be employed at switches or other necessary points along a line of railroad, for the purpose of accommodating the line of track to the constant expansion and contraction which takes place during the day and night from the changes of temperature, and which causes serious trouble from the binding of switch-rails, or even the tearing up of portions of the track. My invention consists in the use of a short curved section or rail, which moves in a curved track at the outside of each line of rails. This track or curve is so situated that the line of rails forms a tangent to it, and the short rail is connected with one end of a rail in the line, so that when the line expands or contracts this short rail moves in its curved track. The end of the rail which meets the one first mentioned is beveled or cut away in a tapering manner, so that the curved piece can pass into the line, and by this construction the wheel will always have a full bearing on the rail, whatever its position.

Referring to the accompanying drawing for a more complete explanation of my invention—

Figure 1 is a perspective view of my device applied to a switch. Fig. 2 shows the joint. Fig. 3 is an adaptation of my device to any portion of the line of road.

A is the stationary end of the throw-rail of the switch. This end is secured in any suitable manner in the chair B. This chair may be made of cast-iron, and is formed with the curved track C, and also so as to hold the end of the rail D securely in place, and at the same time admit of the longitudinal movement of this rail which will be caused by expansion and contraction in the line of rails. E is a

short curved section or rail, which fits into the track or guide C loosely enough to move freely in the line of the curve; but it is held securely in place by being slightly spread or flanged at the bottom, as shown. The bottom part of the rail E is extended out at F, and has an opening made, into which a pin, G, extends from the rail D. By this means any movement of the rail D is communicated to the section E. The succeeding rail I is united to the short rail D by fish-plates in the usual manner. The short section J, which fills the space between the rails A and D, may be made separately, of steel; or it may be cast with the chair B, so as to be rigid, and the top can be case-hardened. The end of this section is beveled away in a curve so as to allow the curved rail E to move past it and form a full connection with the part D.

By this construction I am enabled to give the wheels nearly or quite their full bearing upon the rails whatever may be the position of the curved section E, as the rail D always meets it at a tangent, while by its movements it automatically keeps all the space caused by contraction to be filled, and also allows the necessary room for expansion.

If it is desired to place the device at any portion of the line where there are no switches it is only necessary to make two of the curved sections E, as shown at Fig. 3. These will act to take up all expansion, or fill the space caused by contraction from each direction, and as many may be employed at different points as may be desired.

I have found in practice that with a curve of two feet radius an expansion or movement of nine inches can be allowed, and the triangular space left open at the point of the section J will at no time be more than two inches in length by one-half an inch base, thus making the bearing practically a complete one for the wheels.

Having thus described my invention, what I claim, and desire to secure by Letters Patent, is—

1. The chair B, constructed to receive the line of rails A J D, and provided with the curved track C, substantially as and for the purpose described.

2. The curved rail E, moving in the track C, and connected with the section D, substantially as herein described.

3. The extended lug, perforated as shown, and the pin G on the section D, for uniting the parts D and E and allowing the necessary side movement, substantially as described.

4. An automatic expansion device for rail-

ways, constructed and operating substantially as herein described.

In witness whereof I have hereunto set my hand.

WILLIAM CLOSE.

Witnesses:

GEO. H. STRONG,

JOHN L. SMITH.