

(19)



(11)

EP 1 533 562 B1

(12)

EUROPEAN PATENT SPECIFICATION

(45) Date of publication and mention
of the grant of the patent:
03.10.2007 Bulletin 2007/40

(51) Int Cl.:
F21V 15/02^(2006.01)

(21) Application number: **03026674.6**

(22) Date of filing: **20.11.2003**

(54) **Protective grid for work light**

Schutzgitter für eine Arbeitsleuchte

Grille de protection pour lampe de travail

(84) Designated Contracting States:
BE DE FR GB NL

(43) Date of publication of application:
25.05.2005 Bulletin 2005/21

(73) Proprietor: **All-Line Inc.**
Taipei (TW)

(72) Inventor: **Stekelenburg, Albert**
Taipei (TW)

(74) Representative: **LOUIS, PÖHLAU, LOHRENTZ**
Postfach 3055
90014 Nürnberg (DE)

(56) References cited:
US-A- 1 717 756 **US-A- 5 408 399**
US-A- 5 984 490

EP 1 533 562 B1

Note: Within nine months from the publication of the mention of the grant of the European patent, any person may give notice to the European Patent Office of opposition to the European patent granted. Notice of opposition shall be filed in a written reasoned statement. It shall not be deemed to have been filed until the opposition fee has been paid. (Art. 99(1) European Patent Convention).

Description

Field of the Invention

[0001] The present invention is relating to the lighting device, especially to the work lamp with grid adopted on the rear side thereof.

Background of the invention

[0002] Work lamp or normally known as work light, especially the lighting device having halogen bulb or tube, is a conventional lighting instrument widely used in indoor as well as outdoor, mainly for in work place or plant, and large space lighting. The reasons of using halogen light bulb or tube are that it can produce stronger light and covered by the stiff outer shell.

[0003] Fig. 1 shows the conventional halogen work light, it comprising a main body A, on front side; a lamp, such as halogen bulb or B adopted inside said main body A, and the back (rear) side C of said main body A, provided a wire box D which the electrical wires inside.

[0004] However, on the rear side C of the above-mentioned main body A always causes the heat. Under the high temperature, to those people who repairing, maintenance, as well as working nearby, the risk is always existed.

[0005] In certain working places, always use the portable halogen work light as lighting device. But, due to it always hit by other articles, therefore, in order to prevent the harm caused by hit, the improvement normally is to increase the thickness of the shell of rear portion or whole lighting device.

[0006] US 1 717 756 discloses a protective grid-formed into a wire cage-arranged on the rear side of the housing of a work light to prevent the hands of the operator or other persons from coming in direct contact with this housing which becomes very hot when the work light is illuminated.

Summary of the Invention

[0007] The main object and purpose of the present invention is to provide a protective grid on the rear side of halogen work light.

[0008] Said protective grid including the connecting plate which can be connected to the main body and plurality of grid rods.

[0009] The protective area of said protective grid is in such a way that the wire box can be still bared to enable for installment, repair as well as maintenance.

[0010] Said protective grid can be composed by vertical rods, horizontal rods, slope rods, netting rods and as the like.

Brief description of the drawings

[0011]

Figure 1 is the prospective view of the conventional halogen light.

Figure 2 is the rear prospective view of the main body of the present invention.

Figure 3 is the prospective view of the main body and protective grid of the present invention.

Detailed Description of Preferred Embodiments

[0012] Refer to Fig. 2 & 3, the construction of the present invention is adopt a protective grid on the rear side of main body 10, said protective grid comprising grid body 20 and connecting plate 30 connected respectively.

[0013] Main body 10 is conventional structure and normally comprising a lamp body 11 and a wire box 12 and lamp body 11 further including a rear portion 13.

[0014] In the embodiment of the present invention, proper place around the rear portion 13, provides the connecting member for adopting said protective grid, such as screwing holes 14 and protrusion plate 15.

[0015] Grid body 20 constructed as to cover the rear portion 13 of main body 10. The configuration can be by parallel grids rods, netting or crossed by horizontal and vertical rods. Said rods 21 can be formed by bending and their both ends fixed to the connecting plate 30.

[0016] Said connecting plate 30 is the structure which can be connected to the rear portion 13 of said lamp body 11. As shown in drawings, connecting plate 30 providing the hole 31 which corresponding to screwing holes respectively, it can be but not limited to use screw 32 to connect with said lamp body 11.

[0017] The way and structure of connecting the grid body 20 to the rear portion 13 of said lamp body is limited to the above-mentioned embodiment.

[0018] Refer to drawings, between protective grid and rear portion 13, there are plurality of gap formed by rods to prevent hit, touch or unnecessary contact to said rear portion 13. Meanwhile, by adopting the protective grid in rear portion 13, under the protective grid, there is still an open space which to avoid influence to the wire box 12 as well as relating external connecting devices.

[0019] Due to versatile shapes of lamp body 11, therefore, the protective grid can be designed to comply with the rear portion of lamp body respectively.

[0020] Said main body 10 of work light can be adopted and fixed to the lamp frame as well as adopted as the portable way.

[0021] The embodiment disclosed in the specification is only one of the examples. Any minor change or modification derived from the inventive concept of the present invention will still fall within the scope of the present invention, as defined by the appended claims.

55 **Claims**

1. A halogen work light with a main body (10) comprising a lamp body (11)

and a wire box (12) and with a protective grid adopted in the rear portion (13) of the main body (10), whereby said protective grid of the halogen work light is spaced with the rear portion (13) of said main body (10),

characterized by

a) the main body (10) is providing a connecting member for adopting said protective grid whereby said connecting member is comprising a screwing hole (14) and a protrusion plate (15);
b) said protective grid is comprising a grid body (20) and a connecting plate (30) whereby said grid body (20) is constructed as to cover the rear portion (13) of the main body (10);

c) said connecting plate (30) of the grid body (20) is providing a hole (31) which is corresponding to the screwing hole (14) of the connecting member of the main body (10) to use a screw (32) to connect with said lamp body (11);

d) said protective grid is constructed by plurality of grid rods (21)

whereby both ends of said grid rods (21) are fixed to the connecting plates (30) of the grid body (20);

e) said protective grid is in such a way that the wire box (12) is bared to enable for installment, repair as well as maintenance.

2. A halogen work light as claimed in claim 1, **whereby** the grid rods (21) of the protecting grid are formed by bending.

3. A halogen work light in accordance with any one of the preceding claims, **whereby** the grid rods (21) of the protecting grid are arranged by vertical in parallel, horizontal in parallel, crossed vertical and horizontal as well as crossed by slope rods.

4. A halogen work light in accordance with any one of the preceding claims **whereby** the main body (10) is adopted as the portable way.

Patentansprüche

1. Halogenarbeitsleuchte, mit einem Hauptkörper (10), der einen Lampenkörper (11) und einen Anschlusskasten (12) umfasst, und einem Schutzgitter, das im hinteren Teil (13) des Hauptkörpers (10) vorgesehen ist, wobei das Schutzgitter der Halogenarbeitsleuchte von dem hinteren Teil (13) des Hauptkörpers (10) beabstandet ist,

dadurch gekennzeichnet, dass

a) der Hauptkörper (10) ein Verbindungsorgan zum Anbringen des Schutzgitters aufweist, wobei das Verbindungsorgan eine Gewindebohrung (14) und eine vorstehende Platte (15) aufweist;

b) das Schutzgitter einen Gitterkörper (20) und eine Verbindungsplatte (30) aufweist, wobei der Gitterkörper (20) so beschaffen ist, dass er den hinteren Teil (13) des Hauptkörpers (10) abdeckt;

c) die Verbindungsplatte (30) des Gitterkörpers (20) eine Bohrung (31) aufweist, die der Gewindebohrung (14) des Verbindungsorgans des Hauptkörpers (10) entspricht, damit eine Schraube (32) verwendet werden kann, um eine Verbindung mit dem Lampenkörper (11) zu schaffen;

d) das Schutzgitter aus mehreren Gitterstäben (21) konstruiert ist, wobei beide Enden der Gitterstäbe (21) an den Verbindungsplatten (30) des Gitterkörpers (20) befestigt sind;

e) das Schutzgitter so beschaffen ist, dass der Anschlusskasten (12) freiliegt, um eine Installation, eine Reparatur sowie eine Wartung zu ermöglichen.

2. Halogenarbeitsleuchte nach Anspruch 1, **wobei** die Gitterstäbe (21) des Schutzgitters durch Biegen gebildet sind.

3. Halogenarbeitsleuchte nach einem der vorhergehenden Ansprüche, **wobei** die Gitterstäbe (21) des Schutzgitters vertikal und parallel, horizontal und parallel, gekreuzt und vertikal und horizontal sowie gekreuzt und schräg angeordnet sind.

4. Halogenarbeitsleuchte nach einem der vorhergehenden Ansprüche, **wobei** der Hauptkörper (10) tragbar ausgebildet ist.

Revendications

1. Lampe de travail halogène avec un corps principal (10) comprenant un corps de lampe (11) et un boîtier à fil métallique (12) et avec une grille de protection reçue dans la partie arrière (13) du corps principal (10), ladite grille de protection de la lampe de travail halogène étant disposée à distance de la partie arrière (13) dudit corps principal (10), **caractérisée par**

- a) le corps principal (10) présente un élément de raccordement destiné à recevoir ladite grille de protection
 ledit élément de raccordement comprenant un trou de vissage (14) et une plaque en saillie (15) ; 5
- b) ladite grille de protection comprend un corps de grille (20) et une plaque de raccordement (30), ledit corps de grille (20) étant conçu de façon à couvrir la partie arrière (13) du corps principal (10) ; 10
- c) ladite plaque de raccordement (30) du corps de grille (20) présente un trou (31) qui correspond au trou de vissage (14) de l'élément de raccordement du corps principal (10) pour utiliser une vis (32) pour le raccordement avec ledit corps de lampe (11) ; 15
- d) ladite grille de protection est constituée d'une pluralité de barreaux de grille (21), les deux extrémités desdits barreaux de grille (21) étant fixées aux plaques de raccordement (30) du corps de grille (20) ; 20
- e) ladite grille de protection est conçue de telle sorte que le boîtier à fil métallique (12) est laissé découvert pour permettre les opérations d'installation, de réparation, ainsi que de maintenance. 25
2. Lampe de travail halogène selon la revendication 1, dans laquelle 30
 les barreaux de grille (21) de la grille de protection sont formés par cintrage.
3. Lampe de travail halogène selon l'une quelconque des revendications précédentes, 35
 dans laquelle
 les barreaux de grille (21) de la grille de protection sont agencés verticalement en parallèle, horizontalement en parallèle, sont croisés verticalement et horizontalement et sont croisés par des barreaux en biais. 40
4. Lampe de travail halogène selon l'une quelconque des revendications précédentes, 45
 dans laquelle
 le corps principal (10) est adopté de manière portable. 50

50

55

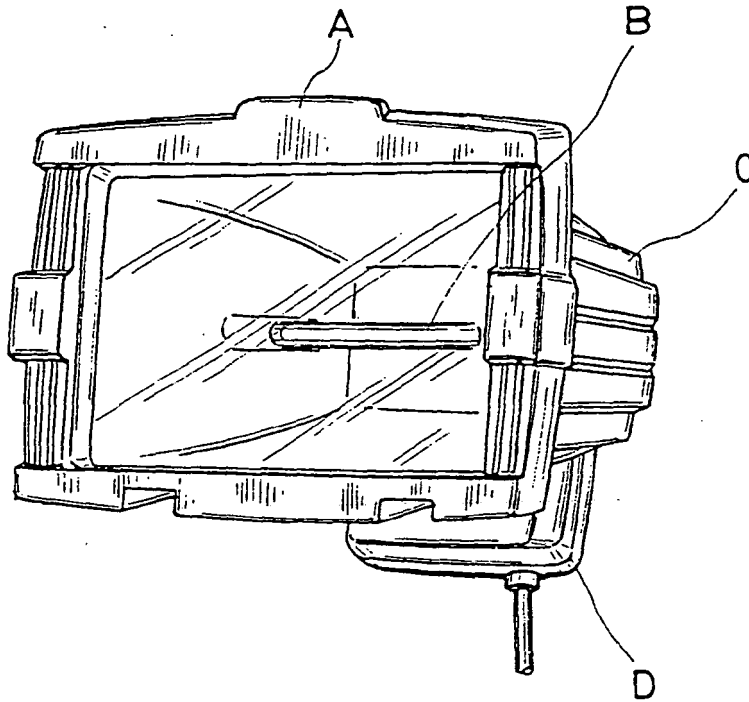

FIG. 1
(PRIOR ART)

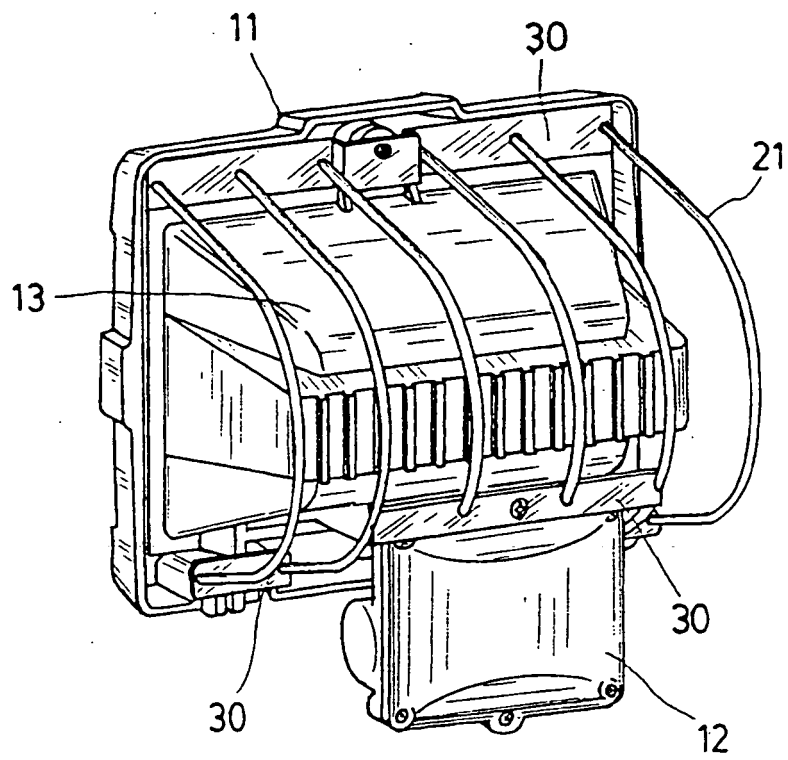

FIG. 2

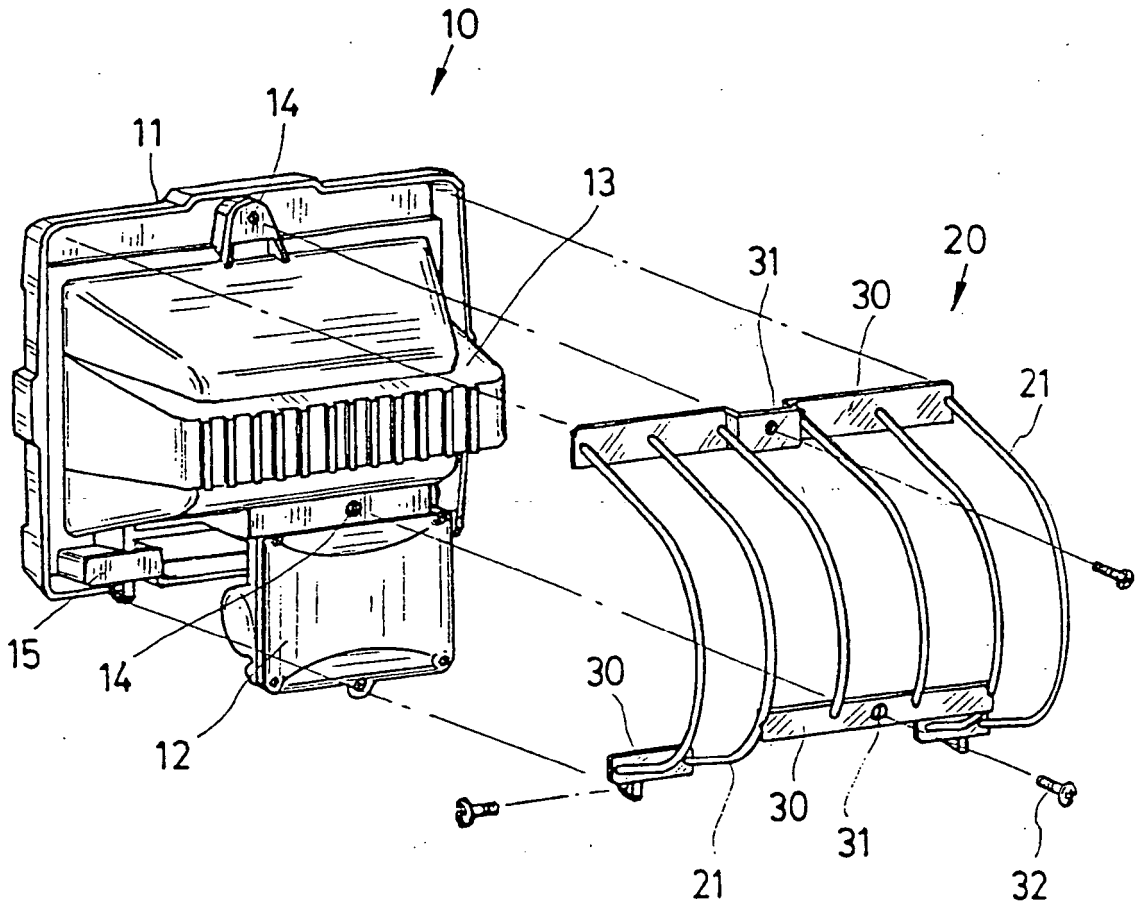

FIG. 3

REFERENCES CITED IN THE DESCRIPTION

This list of references cited by the applicant is for the reader's convenience only. It does not form part of the European patent document. Even though great care has been taken in compiling the references, errors or omissions cannot be excluded and the EPO disclaims all liability in this regard.

Patent documents cited in the description

- US 1717756 A [0006]