

L. WEINFELD.
 THRESHING MACHINE.
 APPLICATION FILED OCT. 27, 1910.

1.014,189.

Patented Jan. 9, 1912.

3 SHEETS-SHEET 2.

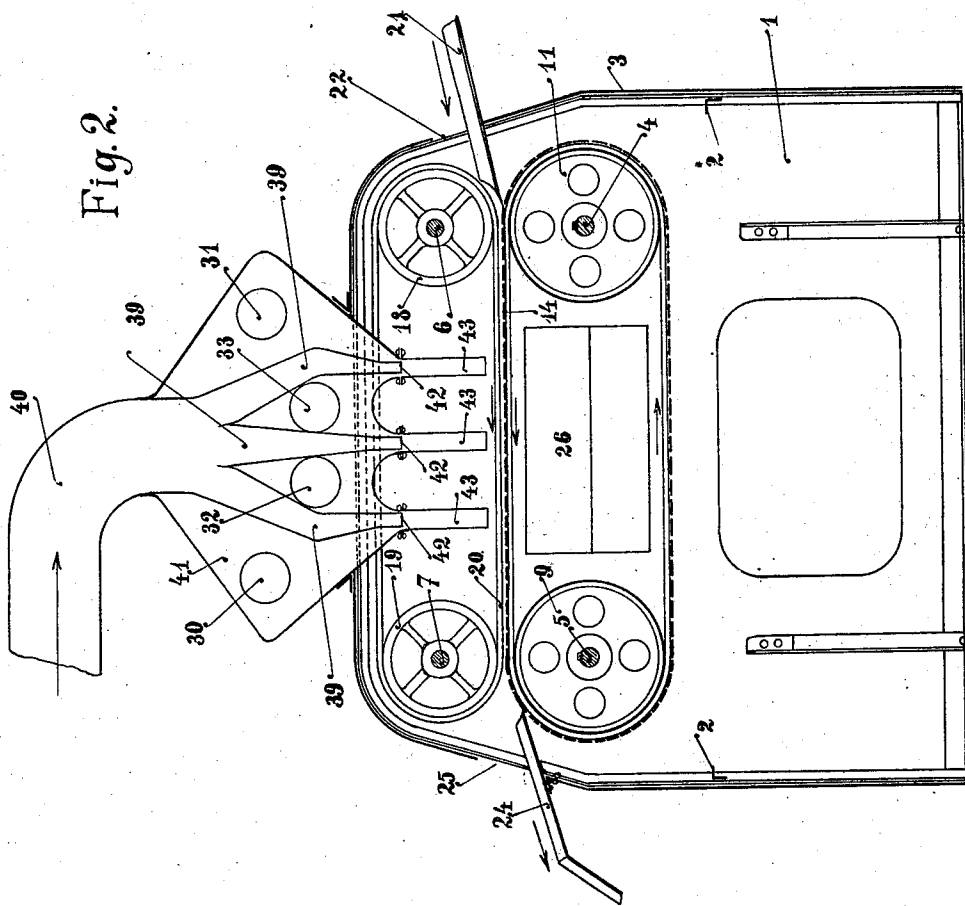

Fig. 2.

Witnesses:

M. Hamilton
Albert Hamilton

Inventor:

Ludwig Weinfeld
 by his attorneys
Hamilton Hamilton
James Hamilton

L. WEINFELD.
 THRESHING MACHINE.
 APPLICATION FILED OCT. 27, 1910.

1,014,189.

Patented Jan. 9, 1912.

3 SHEETS-SHEET 3.

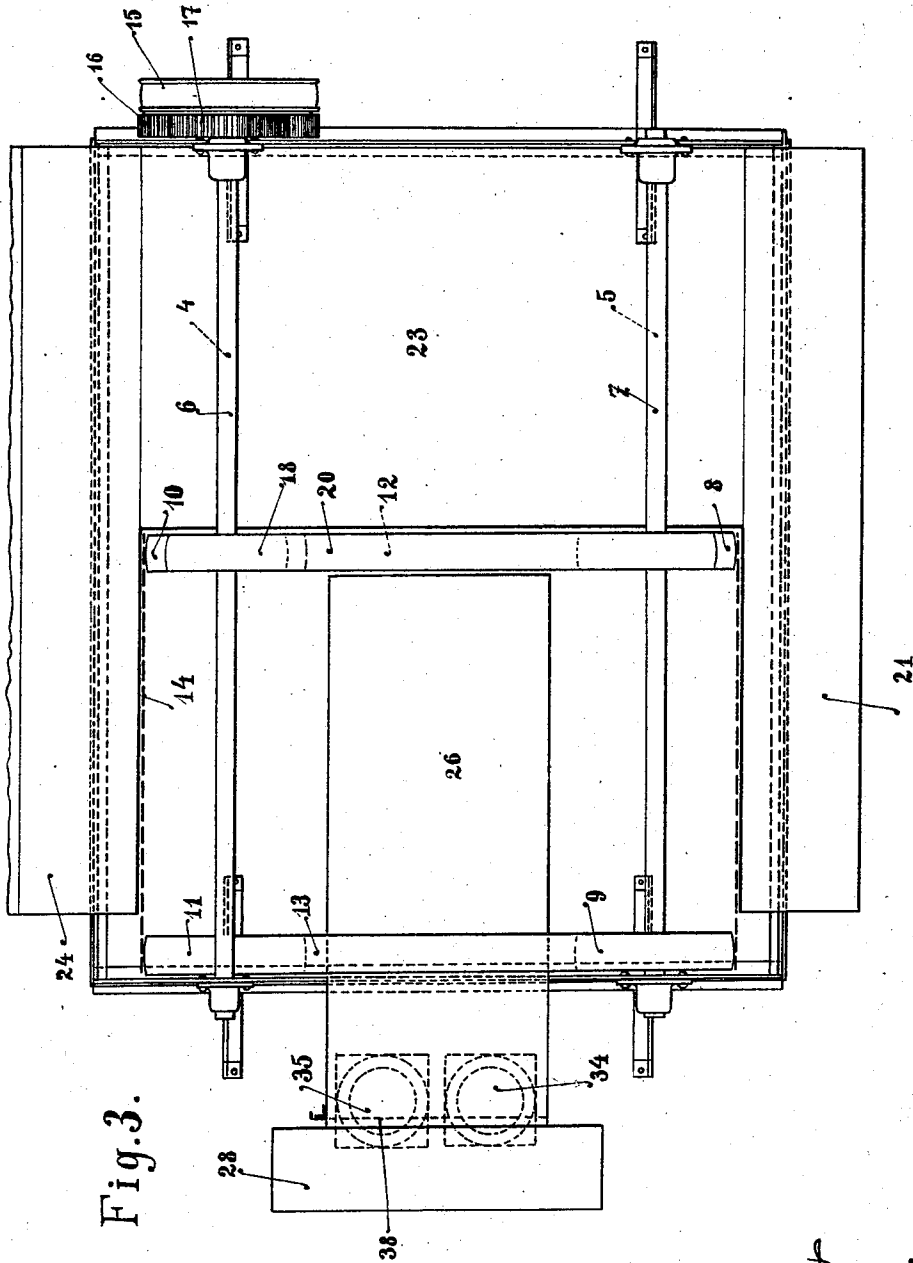

Fig. 3.

Witnesses:

M. Hamilton
Albert Hamilton

Inventor:

Ludwig Weinfeld
 by his attorneys
Hamilton Hamilton
James Hamilton

UNITED STATES PATENT OFFICE.

LUDWIG WEINFELD, OF VIENNA, AUSTRIA-HUNGARY.

THRESHING-MACHINE.

1,014,189.

Specification of Letters Patent.

Patented Jan. 9, 1912.

Application filed October 27, 1910. Serial No. 589,410.

To all whom it may concern:

Be it known that I, LUDWIG WEINFELD, engineer, a subject of the Emperor of Austria-Hungary, residing at Vienna, in the Province of Lower Austria and Empire of Austria-Hungary, have invented certain new and useful Improvements in Threshing-Machines, of which the following is a specification.

This invention relates to a machine for threshing cereals, in which machine hard granular materials, preferably cereal-grains, are thrown with suitable power against the ears, whereby the grains on the ears are removed therefrom. The projectile or missile grains may be flung against the ears, by means of jets of air or vapor.

In the drawings Figure 1 is a sectional elevation of one constructional form of the new threshing machine, Fig. 2 a vertical transverse section, taken at A-A of Fig. 1 and Fig. 3 a plan thereof with the nozzle-containing casing and the upper part of the covering-plate of the machine removed.

The threshing machine illustrated in Figs. 1, 2 and 3 consists of two vertical frames 1 connected together by angle-irons 2. A covering-plate 3 is placed over the two frames 1, whereby there is formed between the latter a chamber which is closed at its top.

The frames 1 carry shafts 4, 5, 6 and 7. On the shaft 4 are keyed the pulleys 10, 11 and the pulleys 8, 9 are similarly mounted on the shaft 5. Over the pulleys 8 and 10 passes an endless belt 12, and over the pulleys 9 and 11 runs another endless belt 13, to which belts an endless screen 14 is attached. The shaft 4 carries also a pulley 15 rigidly connected with a toothed-wheel 16 engaging with a toothed-wheel 17 of the shaft 6. On the latter there is mounted a pulley 18 and the shaft 7 carries a similar pulley 19 which is connected with the pulley 18 by a belt 20 the lower portion of which fits closely against an endless screen 14.

The pulley 15 driven by any suitable power causes the shaft 4 to rotate and by means of the toothed-wheels 16 and 17, the shaft 6 is also rotated, whereby the endless screen 14 and the belt 20 are moved in such a manner that the upper side of the screen 14 and the under side of the belt 20 run in the same direction and with the same speed.

At the front of the machine the lower end of a chute 21 extends through an opening

22 of the cover plate 3 into the interior chamber toward one end of the screen 14 near the top thereof; and from the back of the machine there leads another chute or apron 24 the upper end of which projects through an aperture 25 of the cover plate 3 toward the other end of the screen 14 near the top thereof. At the right hand of the screen 14 (see Fig. 3), the lower end of the chute 21 is connected with the upper end of the chute 24 by a horizontal supporting table 23.

A slanting hopper 26 open on its upper side is arranged between the two horizontal parts of the screen 14 and projects outwardly through an aperture in the left hand frame 1 (Figs. 1 and 3). By means of a curved part 27, the hopper is connected to a vertical rectangular tube 28 which discharges into a reservoir 29 from which lead the tubes 30, 31, 32 and 33. At the lowest point of the curved part 27 of the hopper 26, short tubes 34, and 35 are arranged on each of which a bag 36 may be attached. Each of the short tubes 34 and 35 is provided with a slide-valve 37, by which they may be opened or closed. A slide-valve 38 is provided between the curved part 27 of the hopper 26 and the tube 28. Above the screen 14, nozzles 39 are arranged which project downwardly from the tube 40 and are surrounded by a casing 41, into which the above mentioned tubes 30, 31, 32 and 33 lead from the grain reservoir 29. The ends of the nozzles 39 project into openings 42 of the casing 41, from which openings rectangular downwardly directed tubes 43 riveted to the casing, extend almost to the screen 14.

The operation of the threshing machine is as follows: The halms are placed crosswise on the chute or inclined plane 21 in such a manner that the ears are on the left, reference being made to Fig. 3. The halms slide down the chute 21 and through the aperture 22 of the covering-plate 3 into the interior of the chamber and are fed to the screen 14 which moves in the direction of the arrows, shown in Fig. 2. The halms are thus held between the belt 20 and the screen, move along with the latter through the machine, and pass under the tubes 43 through which air is blown by the nozzles 39. A suitable quantity of cereal grains having been dumped into the casing 41, they fall into the tubes 43 through the clear space of the open-

ings 42. In the tubes 43 the grains are caught in the air blast coming from the nozzles 39 and are thrown violently against the ears fed by the screen 14. The grains on the ears are moved by the projectile or missile grains, so that a perfect projectile or missile results. The threshing grains mixed with the grains removed from the ears fall for the most part through the screen 14 and flow down through the hopper 26 and the short tubes 35 into the bags 36, the slide-valves 37 being opened and slide-valve 38 being closed. If, on the contrary, the slide-valves 37 are closed and the slide-valve 38 is opened, the air blast coming from the nozzles 39 will blow the grains through the hopper 26 and the tube 28 into the grain reservoir 29 and from there through the tubes 30, 31, 32 and 33 into the casing 41. In this way, the casing 41 may always be fed anew with fresh grains for threshing the ears. The casing 41 being again sufficiently filled, the slide-valve 38 is shut and the slide-valves 37 opened, so that the bags may again be filled with threshed grains. The threshed halms, on leaving the screen 14 pass onto the inclined plane 24 and may be gathered outside the machine. They may also be discharged upon a rocking screen or any other cleaning device in order to collect any loose grains still left between the stalks. During the whole threshing process, the halms are maintained perfectly stretched, so that the straw leaves the machine unbroken and fit to be used in manifold ways.

For producing the blast of air in the nozzles 39, the tube 40 communicates with a reservoir of compressed air or with an ordinary blower-fan, the power of which is sufficient for the purpose sought.

It is to be understood that I do not confine myself to the described details of construction of the machine, since the same may be arranged in some different manner for attaining the purpose set out. The feeding devices as well as the carrying devices may be constructed in some other way than that shown in the drawings and instead of leading back part of the threshed out grains to the ballistic or projecting device by means of a blast of air blowing through the machine, the grains may be fed back by means of any other suitable feeding device.

What I claim as my invention and desire to secure by Letters Patent is:

1. Threshing machine comprising the combination of means for flinging hard granular materials with means for producing a relative movement of the ears of cereals transversely to the jets of the said granular materials, for the purpose described.

2. Threshing machine comprising the combination of nozzles fed with compressed air with means for introducing hard granu-

lar materials in the jets of air for giving them a flinging movement, means for leading the ears of cereals transversely to the jets of the said granular materials and means for holding fast the halms on the leading means, for the purpose described.

3. Threshing machine comprising the combination of nozzles fed with compressed air with means for introducing hard granular materials in the jets of air for giving them a flinging movement, means for leading the ears of cereals transversely to the jets of the said granular materials, the said leading means consisting of a perforated movable plane, means for holding fast the halms on the said leading means and means for collecting the cereal grains falling through the perforations of the leading means, for the purpose described.

4. Threshing machine comprising the combination of nozzles fed with compressed air with a casing surrounding the said nozzles and having openings through which the nozzles blow out, the said casing being fed with hard granular materials, which pass the openings of the casing in order to get into the jets of air coming from the nozzles, means for leading the ears of cereals transversely to the jets of the said granular materials, the said leading means consisting of a perforated movable plane, means for holding fast the halms on the leading means and means for collecting the cereal grains falling through the perforations of the leading means, for the purpose described.

5. Threshing machine comprising the combination of nozzles fed with compressed air with a casing surrounding the said nozzles and having openings through which the nozzles blow out, the said casing being fed with hard granular materials which pass the openings of the casing in order to get into the jets of air coming from the nozzles, means for leading the ears of cereals transversely to the jets of the said granular materials, the said leading means consisting of a perforated movable plane, means for holding fast the halms on the leading means, means for collecting the cereal grains falling through the perforations of the leading means and means for connecting the collecting means with the said casing for conducting a portion of the cereal grains into this casing, for the purpose described.

6. Threshing machine comprising the combination of nozzles fed with compressed air with a casing surrounding the said nozzles and having openings through which the nozzles blow out, the said casing being fed with hard granular materials, which pass the openings of the casing in order to get into the jets of air coming from the nozzles, means for leading the ears of cereals transversely to the jets of the said granular materials, the said leading means consisting of

a perforated movable plane, means for holding fast the halms on the leading means, hoppers for collecting the cereal grains falling through the perforations of the leading means and means for connecting the said hoppers with the said casing for conducting a portion of the cereal grains into this casing, for the purpose described.

7. Threshing machine comprising the combination of nozzles fed with compressed air with a casing surrounding the said nozzles and having openings through which the nozzles blow out, the said casing being fed with hard granular materials, which pass the openings of the casing in order to get into the jets of air coming from the nozzles, means for leading the ears of cereals trans-

versely to the jets of the said granular materials, the said leading means consisting of a perforated movable plane, means for holding fast the halms on the leading means, hoppers for collecting the cereal grains falling through the perforations of the leading means and a tube connecting the said hoppers with the said casing for conducting a portion of the cereal grains into this casing, for the purpose described.

In testimony whereof I affix my signature in presence of two witnesses.

LUDWIG WEINFELD.

Witnesses:

SIEGFRIED NEUTRA,
ADA MARIA BERGER.

Copies of this patent may be obtained for five cents each, by addressing the "Commissioner of Patents, Washington, D. C."
