

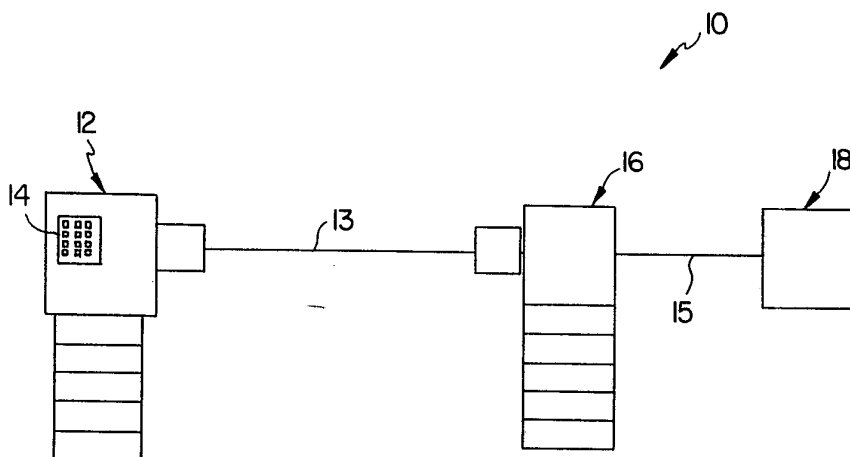

INTERNATIONAL APPLICATION PUBLISHED UNDER THE PATENT COOPERATION TREATY (PCT)

(51) International Patent Classification⁵ : H04M 3/42, H04Q 3/70 H04M 1/274	A1	(11) International Publication Number: WO 93/21720 (43) International Publication Date: 28 October 1993 (28.10.93)
(21) International Application Number: PCT/US93/03572 (22) International Filing Date: 15 April 1993 (15.04.93) (30) Priority data: 101596 15 April 1992 (15.04.92) IL (71) Applicant (for all designated States except US): ENCO-TONE LTD. [IL/IL]; 6 Shlomo Ben-Yosef Str., P.O. Box 25110, 32 961 Haifa (IL). (72) Inventors; and (75) Inventors/Applicants (for US only) : LABATON, Isaac, J. [IL/IL]; 6 Shlomo Ben-Yosef Str., P.O. Box 25110, 32 961 Haifa (IL). KELLY, Michael, K. [US/US]; 2915 East Redfield, Phoenix, AZ 85032 (US).		(74) Agents: LECHTER, Michael, A. et al.; Streich Lang, 2100 First Interstate Bank Plaza, 100 West Washington, Phoenix, AZ 85003-1897 (US). (81) Designated States: CA, JP, KR, US, European patent (AT, BE, CH, DE, DK, ES, FR, GB, GR, IE, IT, LU, MC, NL, PT, SE). Published <i>With international search report.</i>

(54) Title: METHODS AND APPARATUS FOR CONTROLLING ACCESS TO TOLL FREE TELEPHONE SERVICE

**(57) Abstract**

A system (10) for controlling access to communications lines (30) is disclosed. The system includes a personal device (12) and a central device (16). The personal device (12) includes a communications link address circuit embodying a plurality of addresses (44), an algorithm circuit (42), a processor (50) and a transmitting module (22). The processor (50) selects an address in accordance with the algorithm which is transmitted by the module (22). The central device (16) has a selection circuit (60) which designates one of the communication lines (30), retrieved from a candidate circuit (62), as an accessible link in accordance with the algorithm.

FOR THE PURPOSES OF INFORMATION ONLY

Codes used to identify States party to the PCT on the front pages of pamphlets publishing international applications under the PCT.

AT	Austria	FR	France	MR	Mauritania
AU	Australia	GA	Gabon	MW	Malawi
BB	Barbados	GB	United Kingdom	NL	Netherlands
BE	Belgium	GN	Guinea	NO	Norway
BF	Burkina Faso	GR	Greece	NZ	New Zealand
BG	Bulgaria	HU	Hungary	PL	Poland
BJ	Benin	IE	Ireland	PT	Portugal
BR	Brazil	IT	Italy	RO	Romania
CA	Canada	JP	Japan	RU	Russian Federation
CF	Central African Republic	KP	Democratic People's Republic of Korea	SD	Sudan
CG	Congo	KR	Republic of Korea	SE	Sweden
CH	Switzerland	KZ	Kazakhstan	SK	Slovak Republic
CI	Côte d'Ivoire	LI	Liechtenstein	SN	Senegal
CM	Cameroon	LK	Sri Lanka	SU	Soviet Union
CS	Czechoslovakia	LU	Luxembourg	TD	Chad
CZ	Czech Republic	MC	Monaco	TG	Togo
DE	Germany	MG	Madagascar	UA	Ukraine
DK	Denmark	ML	Mali	US	United States of America
ES	Spain	MN	Mongolia	VN	Viet Nam
FI	Finland				

METHODS AND APPARATUS FOR CONTROLLING ACCESS
TO TOLL FREE TELEPHONE SERVICE

Reference to Related Application

5 Reference is made to co-pending PCT Application Serial No. PCT/US92/10492, entitled "Methods and Apparatus for Data Encryption and Transmission" filed by the same inventors. The entire content of the foregoing patent application is hereby incorporated herein by this reference.

10

Technical Field

The present invention relates, generally, to methods and apparatus for controlling access to toll free telephone service, and more particularly to a system for restricting the
15 unauthorized use of toll free telephone numbers by providing a dialing device and a receiving device which cooperate, in accordance with a predetermined algorithm, to effect a desired call completion path.

20 Background Art and Technical Problems

Presently known telephone services, and particularly toll free or "Green Line" telephone services, are increasingly used in the sale and marketing of merchandise, and in the transmission of confidential data and information. In the banking and
25 credit card industries, for example, account information is exchanged and substantial financial transactions are effected through the use of toll free telephone lines.

The providers of services involving toll free access typically
30 assume the financial and security risks associated with the use of toll free lines. In particular, the use of toll free lines is predicated on the idea that the provider of the service agrees in advance to pay for incoming calls, regardless of the geographic source of the call, and further regardless of the
35 identity of the calling party. Consequently, providers of toll free telephone services have experienced considerable fraud and abuse through the unauthorized use of such telephone lines.

Attempts have been made to restrict access to toll free telephone lines, for example by blocking incoming calls from certain area codes or geographic locations. Indeed, certain U.S. providers of toll free telephone service restrict access
5 to the toll free lines to only calls placed from the continental United States. Other providers of toll free telephone services have implemented call blocking functions in which all incoming calls from area codes wherein substantial abuses have occurred are simply precluded from accessing the
10 toll free services. While this is generally effective in curtailing certain unauthorized uses of the toll free lines, it necessarily reduces the effectiveness of the toll free service inasmuch as large segments of potentially desirable users are precluded from using the toll free services.

15

Perpetrators of toll free telephone fraud have developed sophisticated equipment and techniques for intercepting dual tone multi-frequency (DTMF) transmission of toll free telephone numbers, as well as confidential (financial credit card)
20 information often transmitted in connection with a toll free call. Once intercepted, the toll free telephone numbers and confidential information are often subsequently used to perpetrate financial fraud on the account holders as well as the toll free service providers. Specifically, an unauthorized
25 user in possession of a toll free number and/or access code may utilize this information to access toll free lines and, in some circumstances, access the accounts as well. Moreover, tracing the identity of the unauthorized user is inherently problematic inasmuch as such fraud is often effected through the use of
30 telephones, rather than in person.

A system is thus needed which permits providers and users of toll free telephone service the flexibility of convenient access to the toll free numbers, yet which precludes the
35 fraudulent use of data transmitted over public telephone lines.

Summary of the Invention

The present invention provides methods and apparatus for controlling access to toll free telephone lines which overcomes many of the short-comings of the prior art.

5 In accordance with one aspect of the present invention, a transmitting device ("personal device") is configured to select one of a plurality of telephone numbers in accordance with a predetermined algorithm embedded in the transmitting device. Once a particular telephone number is selected, a DTMF data
10 packet is transmitted to a central device configured to cooperate with the telephone switch (e.g. PBX) located at the toll free service provider's facility. The central device also incorporates the foregoing algorithm used by the personal device to select the transmitted telephone number. In
15 addition, the central device includes a plurality of telephone lines, corresponding to the plurality of telephone numbers associated with the personal device. In accordance with the foregoing algorithm, one of the plurality of telephone lines is designated as the accessible line at any given instant; the
20 remaining telephone lines are inaccessible. The accessible telephone line at any given instant corresponds to the particular telephone number selected by the personal device at that time.

25 In accordance with another aspect of the invention, the telephone number selected and transmitted by the personal device, and the accessible telephone line selected by the central device, are updated in a predetermined fashion in accordance with the foregoing algorithm. Thus, each accessible
30 telephone number line communication path remains valid for a predetermined time period as determined by the algorithm. Thus, in the event a DTMF transmission of a telephone number is intercepted by an unauthorized user, the toll free number and associated account data may not readily be used, because
35 the unauthorized user lacks access to the algorithm used to determine the discreet windows of time during which the

particular intercepted toll free number constitutes the accessible telephone line.

Brief Description of the Drawing Figures

5 The subject invention will hereinafter be described in conjunction with the appended drawing figures, wherein like numerals denote like elements, and:

Figure 1 is a schematic block diagram of a toll free telephone
10 line control system;

Figure 2 is a schematic block diagram of the personal device shown in Figure 1;

15 Figure 3 is a schematic block diagram of the central device shown in Figure 1; and

Figure 4 is a schematic block diagram of an exemplary telephone line selection implementation in accordance with the present
20 invention.

Detailed Description of a Preferred Exemplary Embodiment

A preferred embodiment of the toll free telephone line control system which is the subject of the present invention is
25 conveniently described in the context of a credit card/financial account access scheme. Those skilled in the art will appreciate, however, that the subject invention may be employed in any suitable context involving the use of any data communications path, including but not limited to communication
30 paths involving toll telephone service, wireless communication paths, and the like.

Referring now to Figures 1-4, an exemplary embodiment of a toll free telephone access control system 10 suitably comprises a
35 personal device 12 including a key pad 14, a central device 16, a switch 18, and respective voice/data communication links 13 and 15, for example conventional telephone lines.

Communications link 13 is configured to maintain communication between personal device 12 and central device 16. Communications link 13 suitably comprises conventional public telephone company communication lines.

5

Switch 18 suitably comprises a conventional telephone switch board, for example, a private branch exchange (PBX). Switch 18 may be conveniently located at the facilities of the company which provides the toll free telephone service. In
10 circumstances where a toll free number is used to access a computer to retrieve information relating to, for example, savings, checking or credit card accounts and the like, switch 18 may be advantageously configured to communicate directly with such a computer system (not shown). Alternatively, switch
15 18 may be configured to direct incoming toll free telephone calls to various human operators, as desired.

Those skilled in the art will appreciate that switch 18 typically interfaces with communications link 13 via a
20 conventional telephone interface system, for example, a T1 line. In accordance with a preferred embodiment of the present invention, central device 16 is suitably interposed between the T1 line and switch 18. Consequently, an incoming call received at the T1 interface may be appropriately routed through central
25 device 16 to switch 18, as discussed in greater detail below.

As an alternate embodiment, switch 18 can be positioned before the central device 16 if desired. The alternate embodiment is particularly useful when direct inward dialing technology is
30 employed. In direct inward dialing, a group of n telephone numbers and m physical telephone lines, $n \gg m$, is allocated to a customer. In this scenario, the switch 18 will select the physical line to be used by an incoming number. The central device 16 then determines accessibility as discussed herein.

35

With particular reference to Figure 2, personal device 12 suitably comprises a control unit 20, for example a micro-

processor, microcontroller, or other central processing unit (CPU), a dual tone multi-frequency (DTMF) module 22, a RAM 24, and key pad 14.

5 RAM 24 suitably comprises a plurality of memory sectors, including an algorithm sector 42, a telephone number sector 44, a protocol sector 46, a code sector 48 and a control sector 50. Control sector 50 suitably embodies various control software for performing supervisory, communication, and other system
10 level functions. Code sector 48 suitably comprises data corresponding to a personal identification number (PIN) or other identifying code corresponding to the individual or entity to which the particular personal device 12 has been assigned, as discussed in greater detail below. Protocol
15 sector 46 suitably comprises data corresponding to predetermined protocol and other related communication parameters for maintaining proper coordination between personal device 12 and central device 16, as discussed in greater detail below. Telephone number sector 44 suitably includes a
20 plurality of toll free telephone numbers, one of which is suitably selected in accordance with a predetermined algorithm or mathematical function resident in algorithm sector 42.

In accordance with one aspect of the present invention, key
25 pad 14 is used to enter an access code, e.g., a PIN, and a telephone number or other enabling number assigned to personal device 14 by the provider of the subject toll free telephone service.

30 In accordance with a further aspect of the invention, entry by the user of a PIN or other access code into key pad 14 enables device 12 to perform the functions described herein. As an additional security mechanism, device 12 may be configured to select a second PIN number from PIN sector 48 in accordance
35 with the aforementioned algorithm. The second PIN number retrieved from PIN sector 48 may advantageously be transmitted to central device 16 along with the selected telephone number.

In this way, an unauthorized user who observes or otherwise intercepts the PIN number entered onto key pad 14 will not thereby gain access to the second PIN number actually transmitted. Conversely, an unauthorized user who intercepts
5 the second PIN number which is actually transmitted will not necessarily thereby derive the PIN number entered onto key pad 14 by the authorized user.

Upon entering the foregoing information, the algorithm embedded
10 in RAM 24 (discussed in greater detail below) selects one of the plurality of toll free telephone numbers resident in telephone number sector 44 of RAM 24. In accordance with various control software resident in control sector 50 and various protocol parameters resident in protocol sector 46, the
15 selected toll free telephone number is applied to DTMF module 22. DTMF module 22 generates a data packet comprising DTMF tones corresponding to the selected telephone number and applies this data packet to communications link 13. In practical effect, personal device 12 dials a toll free
20 telephone number, selected in accordance with the predetermined algorithm embedded within personal device 12, in response to the entry of the access information (e.g., PIN and telephone number) by the user of personal device 12.

25 With particular reference to Figure 3, central device 16 suitably comprises a controller 26, for example a micro-processor, microcontroller, or other suitable control device, and a RAM 25 including a function sector 60, a telephone line sector 62, a protocol sector 64, a PIN sector 66, and a control
30 sector 68. Control sector 68 suitably embodies software for supervisory control, system level function, and the like. PIN sector 66 suitably includes a look-up table or other memory array for maintaining PIN or other access code numbers. Protocol sector 64 embodies protocol and other parameters for
35 maintaining communication with personal device 12. Telephone number sector 62 suitably comprises the addresses or other identifying parameters corresponding to the plurality of toll

free telephone lines maintained by the provider of the toll free service which is the subject of the present invention. Function sector 60 suitably comprises a function or other algorithm which is either identical to or compatible with the
5 algorithm executed by personal device 12, as discussed in greater detail below.

A suitable communications interface module 17, for example a T1 line interface module, is configured to receive DTMF tones
10 from personal device 12. Those skilled in the art will appreciate that appropriate DTMF compatible hardware and software may be employed in conjunction with interface module 17 and central device 16 to ensure the compatible operation of central device 16 with the DTMF-transmitted data.

15

In accordance with a further aspect of the invention, access to a toll free telephone line is controlled by central device 16 such that access is limited to personal devices 12.

20 More particularly, switch 18 includes a number of telephone lines owned or otherwise operated by the provider of the toll free service. Of these, a discrete group of telephone lines are designated as candidate lines for the purpose of this invention. Central device 16, in accordance with the
25 predetermined algorithm embedded therein, selects one of these candidate lines to be the accessible line at any given moment; the remaining candidate lines remain inaccessible and, hence, are incapable of receiving incoming telephone calls.

30 As discussed above, personal device 12 selects a particular telephone number from a plurality of telephone numbers set forth in telephone number sector 44 of RAM 24, in accordance with an algorithm which is identical (or at least compatible) with the algorithm used by central device 16 to select the
35 accessible line. Thus, at any particular point in time, the telephone number selected and dialed by personal device 12 corresponds to the accessible line selected by central device

16. Inasmuch as all of the candidate lines except the accessible line are inaccessible, only the telephone number selected by personal device 12 which corresponds to the accessible line is capable of establishing communication
5 between personal device 12 and switch 18. Consequently, an unauthorized user not in possession of personal device 12 is precluded from accessing the toll free telephone lines controlled by central device 16, inasmuch as the unauthorized user has no way of determining which of the plurality of
10 candidate lines is the accessible line at any given moment. Indeed, if the toll free telephone number corresponding to any one of the candidate telephone lines which is not then the current accessible line is dialed, communication will not likely be established because the telephone line corresponding
15 to the dialed number is likely to be disconnected, or if connected, such connection will be momentary due to lack of appropriate protocol.

Once the toll free telephone call is placed through the
20 accessible line, thereby establishing communication between personal device 12 and switch 18, the accessible line remains active until the call is terminated by the user of personal device 12. In this regard, the algorithm embodied in central device 16 may either cease operating for the duration of the
25 telephone call, or may continue to operate, allowing additional parties to establish communication with additional telephone lines, as desired.

In accordance with another aspect of the invention, a plurality
30 of identical or similarly programmed personal devices 12 are provided to a select group of individuals or entities designated by the provider of the toll free service as having access to the toll free telephone lines controlled by central device 16. By entering the appropriate enabling codes into
35 personal device 12, an authorized user may readily access the then current accessible line, even though the user of the device has no way of knowing which line is accessible. That

is, the selection of the appropriate telephone number by personal device 12 and the concomitant designation of a corresponding accessible telephone line by central device 16 is transparent to an authorized user.

5

In an alternate embodiment of the invention, two or more telephone lines may be selected and sequentially transmitted by personal device 12, while two or more telephone lines corresponding thereto are simultaneously made accessible by
10 central device 16, thereby facilitating higher volume telephone traffic.

In accordance with a further aspect of an invention, the unauthorized interception of DTMF signals does not thereby
15 permit access to one of the toll free lines controlled by central device 16. In particular, if the DTMF signal corresponding to the dialed telephone number (and, hence, corresponding to the then active line) is intercepted during transmission, the unauthorized interception may be analyzed to
20 reveal the dialed telephone number. However, if this dialed number is subsequently dialed by the unauthorized user, chances are remote that the intercepted telephone number will correspond to the accessible line at any arbitrary time during which the unauthorized user attempts to access the toll free
25 line. Moreover, the actual data which is transmitted in accordance with the subject invention may be encrypted to inhibit the determination of the dialed number and PIN number by an unauthorized user who has intercepted the data. Suitable encryption schemes are set forth in a related PCT Application
30 entitled "Methods and Apparatus for Data Encryption and Transmission" filed on December 4, 1992 by the same inventors.

Referring now to Figure 4, an exemplary scheme for selecting an active line from a plurality of candidate lines suitably
35 comprises a multiplexer 28 having select lines S1, S2 . . . Sn and a plurality of candidate telephone lines schematically represented as respective lines 30 interposed between

multiplexer 28 and communications interface module 17. Those skilled in the art will appreciate that the function of multiplexer 28 may be implemented in hardware or software as part of central device 16, as desired.

5

With continued reference to Figure 4, the algorithm resident in central device 16 applies logical signals to respective select lines S1-Sn to thereby designate a particular one of candidate lines 30 as the accessible link. Although the particular candidate line which functions as the accessible line changes periodically as a function of the foregoing algorithm, at any given moment the accessible line functions to maintain communication between communications link 13 and switch 18 via a second communications link 15. By varying the logical signals applied to select lines S1-Sn in accordance with the algorithm, a different one of candidate lines 30 constitutes the accessible line at any given moment.

The aforementioned process is applicable to telephone systems that use hunting group technology. In a hunting group, a block of telephone numbers is set up in an exchange such that an incoming call which encounters a busy number is routed to an open line. Usually, but not always, a leading number is used for all incoming calls. The present invention is able to determine that leading number at any given point in time. Access to all other numbers would be restricted.

In accordance with another aspect of the present invention, the selection algorithm suitably comprises a dynamic mathematical function of time (e.g., Greenwich Mean Time ("GMT")) expressed in terms of, for example, the current year, month, date, hour, minute and/or second. Inasmuch as the same dynamic mathematical function is employed in both personal device 12 and central device 16, the telephone number selected by personal device 12 to be dialed desirably corresponds to the accessible line selected by central device 16. However, those skilled in the art will appreciate that typical DTMF

transmission requires on the order of 30 milliseconds per digit. Thus, transmission of a data packet comprising, for example, 15-20 digits may require on the order of 450-600 milliseconds. Thus, it may be desirable to employ a suitable
5 mechanism for ensuring that a data packet transmitted by personal device 12 is received and processed by central device 16 during a particular state of the subject algorithm ("validity window"); stated another way, a selected telephone number remains valid for a particular validity window defined
10 by the execution of the algorithm by personal device 12. In addition, the particular accessible line selected by central device 16 remains valid (accessible) for a particular validity window defined by central device 16. Accordingly, it may be desirable to offset the operation of the algorithm within
15 central device 16 with respect to the operation of the algorithm within personal device 12 by a predetermined period of time sufficient to account for the time required to transmit the DTMF signals from personal device 12 to central device 16.

20 Alternatively, personal device 12 may be configured to monitor each validity window and to delay transmission of a data packet until the beginning of a subsequent validity window of sufficient duration to ensure satisfactory transmission of a data packet within a validity window. As yet a further
25 alternative, a data packet may be transmitted by personal device 12 without regard to whether sufficient time remains within the then current validity window to transmit the data packet to central device 16. In the event the validity window associated with central device 16 changes before central device
30 16 processes the data packet received from personal device 12, central device 16 may be configured to transmit an appropriate message to personal device 12 requesting that a new telephone number be transmitted. This process may be repeated a number of times until a data packet is successfully transmitted and
35 processed within a validity window.

Those skilled in the art will also appreciate that personal device 12 and central device 16 suitably include an appropriate mechanism (not shown) for monitoring or otherwise generating a signal representative of GMT. For example, personal device 5 12 and central device 16 may comprise an internal hardware or software clocking mechanism configured to track GMT, which mechanism may be periodically recalibrated to coincide with GMT. Alternatively, the respective devices 12, 16 may comprise a signal input terminal for directly receiving a signal 10 representative of GMT from an external source. Those skilled in the art will further appreciate that the subject algorithm may be based on a time value which is either offset from or otherwise a function of GMT or some other dynamic variable which may be conveniently calibrated from time to time to 15 ensure synchronous operation between personal device 12 and central device 16.

In accordance with a further aspect of the present invention, the subject selection algorithm may comprise any suitable 20 algorithm, including but not limited to a mathematical function which sequentially selects an accessible line from among the various candidate telephone lines. For example, a simple function $F(T)=1+T^2$, where T corresponds to the output of a hardware or software counter (not shown) which is controlled 25 (incremented) by GMT, may be employed to select among the various candidate lines, each candidate line having an address corresponding to the various anticipated values of $F(T)$. Alternatively, a counter or analogous device may be employed to sequentially designate each candidate line as the accessible 30 line in a repeating sequence, wherein the period of time in which a particular telephone line remains active is controlled by a predetermined function.

In accordance with the further aspect of the invention, 35 personal device 12 assembles a data packet including the aforementioned DTMF signals and which also comprises a PIN or other code which identifies a particular personal device 12

either uniquely or as one of a predefined class of devices. When the data packet is received by central device 16, controller 26 extracts the PIN from the data packet and applies the PIN code number as an argument to PIN sector 66 of RAM 25.

5 In this regard, PIN sector 66 may comprise a look-up table which associates the PIN number received from personal device 12 with a particular authorized user. In this way, central device 16 may ascertain which user has dialed the toll free number and, hence, central device 16 may thereby discriminate

10 among various users. For example, the provider of the subject toll free telephone service may desire to limit the ability of certain users to access certain telephone numbers only at predetermined times or only from predetermined locations. Moreover, if a personal device is reported as stolen, this

15 information may be incorporated into PIN sector 66, and access to the toll free numbers from the stolen device may be restricted, as desired.

Although the invention has been described herein in conjunction

20 with the appended drawing figures, those skilled in the art will appreciate that the scope of the invention is not so limited. Various modifications in the selection and arrangement of the various components and method steps discussed herein may be made without departing from the spirit

25 of the invention as set forth in the appended claims.

CLAIMS**We claim:**

1. A System for controlling access to communication links, comprising:
 - 5 a personal device, comprising:
 - a communication link address circuit embodying a plurality of addresses;
 - an algorithm circuit configured to effect a predetermined algorithm;
 - 10 a processor configured to select one of said plurality of addresses in accordance with said algorithm; and
 - a transmitting module configured to transmit a data packet corresponding to said selected address over a data link;
 - 15 a central device configured to communicate with said personal device through said data link, said central device comprising:
 - a candidate circuit configured to store indicia of a plurality of said communication links;
 - 20 a selection circuit configured to designate one of said communication links as an accessible link in accordance with said algorithm to thereby establish communication between said personal device and said central device.
- 25 2. The System of Claim 1 wherein said algorithm circuit is configured to effect an algorithm which is a mathematical function of GMT.
- 30 3. A method for controlling access to communication links, comprising the steps of:
 - entering an access code into a personal device;
 - selecting a communication link address from a set of said communication link addresses in accordance with a predetermined
 - 35 algorithm;
 - transmitting said selected address to a central device comprising a plurality of said communication links;

designating one of said plurality of communication links as an accessible link corresponding to said selected address in accordance with said algorithm; and

establishing communication between said personal device and
5 said central device through said accessible link.

4. The Method of Claim 3, wherein said step of selecting one of a plurality of said communication link addresses in accordance with a predetermined algorithm comprises selecting
10 said address in accordance with a mathematical function of GMT.

5. A method for controlling access to telephone service to authorized users, the method comprising the steps of:

devoting a plurality of telephone lines to the service;
15 associating each of the plurality of lines with a value, each of the values being derivable from a mathematical function;

periodically computing one of the values from the mathematical function;

20 selecting one or more of the plurality of telephone lines corresponding to the computed value, the one or more of the telephone lines being accessible for telephone service, the remaining lines of the set are inaccessible for telephone service; and

25 providing the accessible number to the authorized users.

6. The method of claim 5 wherein the mathematical function utilizes the date and the time as variables.

30 7. The method of claim 5 wherein a plurality of mathematical functions are utilized.

8. The method of claim 5 further comprising the step of limiting access to the mathematical function to the authorized
35 users.

9. The method of claim 8 wherein the step of limiting access further comprises furnishing the authorized users with an access code; and

requiring that the access code be transmitted and received
5 before use of the accessible line is permitted.

10. The method of claim 9 wherein the step of limiting access further includes encoding the access code by performing a mathematical transform on the access code input by the
10 authorized user, and transmitting the transformed access code.

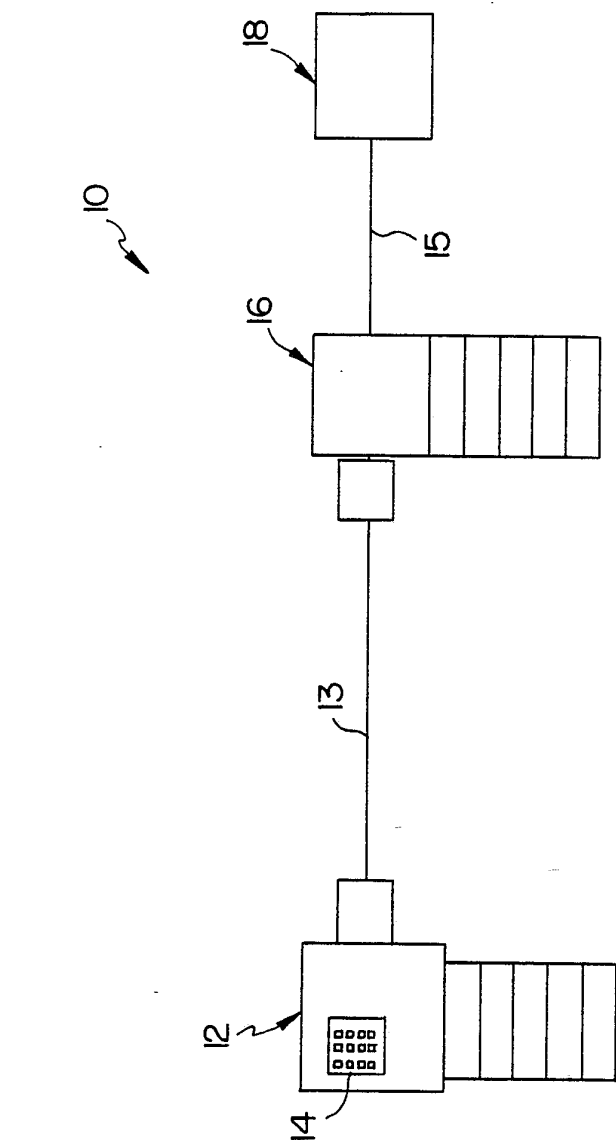

FIG. 1

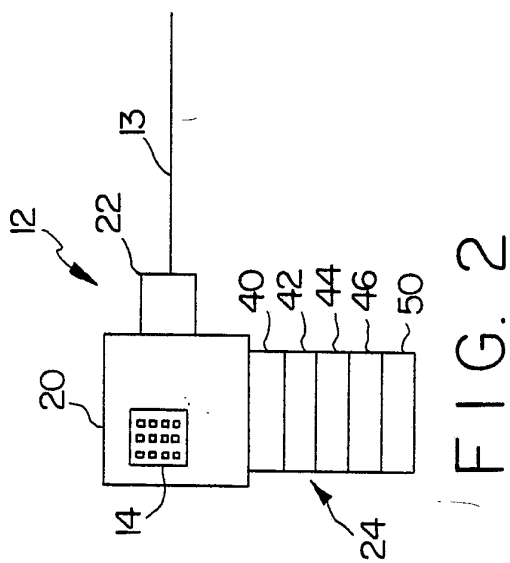

FIG. 2

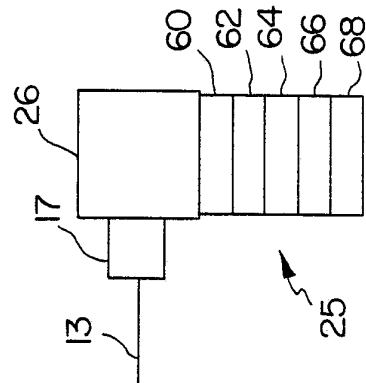

FIG. 3

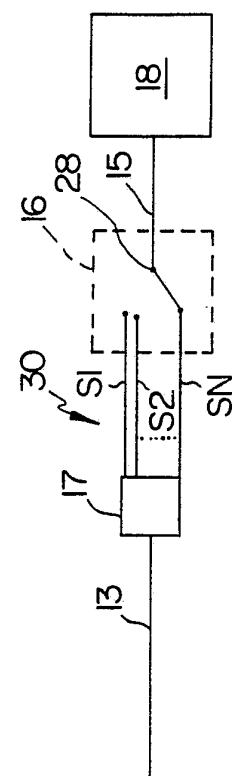
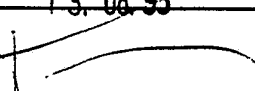

FIG. 4

INTERNATIONAL SEARCH REPORT

International Application No

PCT/US 93/03572

I. CLASSIFICATION OF SUBJECT MATTER (if several classification symbols apply, indicate all) ⁶		
According to International Patent Classification (IPC) or to both National Classification and IPC		
Int.Cl. 5 H04M3/42; H04Q3/70; H04M1/274		
II. FIELDS SEARCHED		
Minimum Documentation Searched ⁷		
Classification System	Classification Symbols	
Int.Cl. 5	H04M ; H04Q ; H04L	
Documentation Searched other than Minimum Documentation to the Extent that such Documents are Included in the Fields Searched ⁸		
III. DOCUMENTS CONSIDERED TO BE RELEVANT⁹		
Category ^o	Citation of Document, ¹¹ with indication, where appropriate, of the relevant passages ¹²	Relevant to Claim No. ¹³
A	US,A,4 761 808 (HOWARD) 2 August 1988 see column 2, line 44 - column 3, line 2 ---	1-10
A	PATENT ABSTRACTS OF JAPAN vol. 11, no. 271 (E-536)3 September 1987 & JP,A,62 072 266 (KOMAKI NORIO) 2 April 1987 see abstract ---	1-10
A	BELL SYSTEM TECHNICAL JOURNAL vol. 61, no. 7, September 1982, NEW YORK US pages 1737 - 1744 D.SHEINBEIN 'STORED PROGRAM CONTROLLED NETWORK: 800 SERVICE USING SPC NETWORK CAPABILITY' see page 1744, line 3 - line 5 -----	
<p>^o Special categories of cited documents : ¹⁰</p> <p>"A" document defining the general state of the art which is not considered to be of particular relevance</p> <p>"E" earlier document but published on or after the international filing date</p> <p>"I" document which may throw doubts on priority claim(s) or which is cited to establish the publication date of another citation or other special reason (as specified)</p> <p>"O" document referring to an oral disclosure, use, exhibition or other means</p> <p>"P" document published prior to the international filing date but later than the priority date claimed</p> <p>"T" later document published after the international filing date or priority date and not in conflict with the application but cited to understand the principle or theory underlying the invention</p> <p>"X" document of particular relevance; the claimed invention cannot be considered novel or cannot be considered to involve an inventive step</p> <p>"Y" document of particular relevance; the claimed invention cannot be considered to involve an inventive step when the document is combined with one or more other such documents, such combination being obvious to a person skilled in the art.</p> <p>"&" document member of the same patent family</p>		
IV. CERTIFICATION		
Date of the Actual Completion of the International Search	Date of Mailing of this International Search Report	
10 AUGUST 1993	13. 08. 93	
International Searching Authority	Signature of Authorized Officer	
EUROPEAN PATENT OFFICE	VANDEVENNE M.J. 	

**ANNEX TO THE INTERNATIONAL SEARCH REPORT
ON INTERNATIONAL PATENT APPLICATION NO.**

US 9303572
SA 73593

This annex lists the patent family members relating to the patent documents cited in the above-mentioned international search report. The members are as contained in the European Patent Office EDP file on
The European Patent Office is in no way liable for these particulars which are merely given for the purpose of information. 10/08/93

Patent document cited in search report	Publication date	Patent family member(s)	Publication date
US-A-4761808	02-08-88	None	
