



- (51) **International Patent Classification:**
C07H 21/02 (2006.01) *C12Q 1/68* (2018.01)
- (21) **International Application Number:**
PCT/IL2019/050741
- (22) **International Filing Date:**
03 July 2019 (03.07.2019)
- (25) **Filing Language:** English
- (26) **Publication Language:** English
- (30) **Priority Data:**
PCT/IL2018/050726
04 July 2018 (04.07.2018) IL
PCT/IL2018/051400
27 December 2018 (27.12.2018) IL
- (71) **Applicant: ADOR DIAGNOSTICS LTD.** [CY/CY]; 28 Oktovriou, 313, Omrania Building, 3rd Floor, Limassol, 3105 (CY).
- (72) **Inventor; and**
(71) **Applicant (for BB only): TADMOR, Ari** [IL/IL]; 13 Yair Stern Street, 4641213 Herzlia (IL).
- (72) **Inventors: SCHNELL, Amit**; 21 Nuriyot, 3606811 Kiryat Tivon (IL). **HODKO, Dalibor**; 13334 Gem Court, Poway, San Diego, California 92064 (US). **SWANSON,**

Paul D.; 10854 Susie Lane, Santee, California 92071 (US). **HURGIN, Vladimir**; 45 Natan Alterman Street, 7085147 Gan Yavne (IL). **SCHMITT, Mario**; 1a Ulmenweg, 66482 Zweibruecken (DE). **WEBER, Lutz**; Tunnelstr. 2, 66981 Muenchweiler (DE). **LIPSHITZ, Asaf**; 57/5 Rahel Imenu Street, 7177108 Modiin (IL). **ZAHAVI, Eran**; 12 Carmel Street, 7630512 Rehovot (IL). **NEUMEIER, Michel**; Bliestalstr. 29a, 66399 Mandelbachtal (DE). **ROZIN, Gideon**; 2 Lehi Street, Kiryat Ono (IL). **YAO, Zuxu**; 13388 Cooper Greens Way, San Diego, California 92129 (US). **HODKO, Nives**; 13334 Gem Court, Poway, San Diego, California 92064 (US). **SIRIS, Genrikh**; Am Heimgarten 63, 82024 Taufkirchen (DE). **RZEHAK, Otto**; Gorresstrasse 7, 80798 Munich (DE). **SECHSER, Benjamin**; Therese-Giehse-Allee 35, 81739 Munich (DE). **KAISER, Stefan**; Margit-Schramm Str. 23, 80639 Munich (DE). **DEUTER, Klaus**; St. Ulrichstr. 12a, 85716 Unterschleissheim (DE).

(74) **Agent: SANFORD T. COLB & CO.** et al.; 4 Shaar Hagai Street, P.O. Box 2273, 7612201 Rehovot (IL).

(81) **Designated States (unless otherwise indicated, for every kind of national protection available):** AE, AG, AL, AM, AO, AT, AU, AZ, BA, BB, BG, BH, BN, BR, BW, BY, BZ, CA, CH, CL, CN, CO, CR, CU, CZ, DE, DJ, DK, DM, DO, DZ, EC, EE, EG, ES, FI, GB, GD, GE, GH, GM, GT, HN, HR, HU, ID, IL, IN, IR, IS, JO, JP, KE, KG, KH, KN, KP,

(54) **Title:** SYSTEM, APPARATUS AND METHOD FOR COMPUTERIZED AUTOMATIC DIAGNOSIS

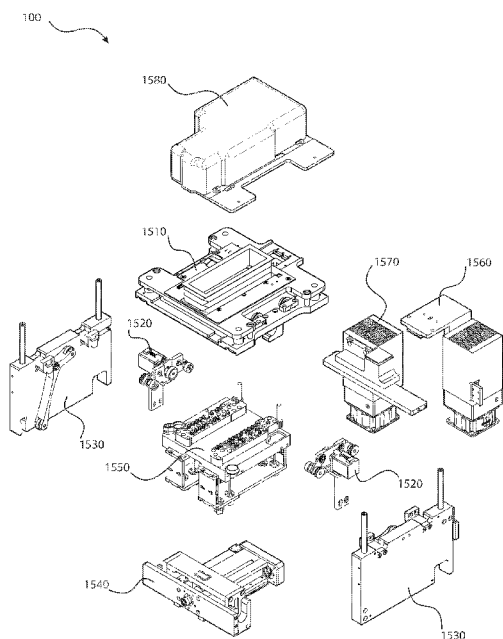

Fig. 11B

(57) **Abstract:** A computerized automated diagnostic system including a cartridge configured to contain reagents for carrying out a diagnostic biological process and to receive a biological sample to be tested using the reagents and an instrument operative to interact with the cartridge to carry out multiple steps in the diagnostic biological process, the cartridge having multiple operative states including a non-functionalized state in which the cartridge does not include the reagents and does not include the biological sample, a partially functionalized state in which the cartridge does include the reagents and does include the biological sample and in which a carbon array assembly is mounted onto the cartridge and forms part of the cartridge and a fully functionalized state upon insertion of the cartridge, onto which the carbon array assembly is mounted, into clamped engagement with the instrument.



KR, KW, KZ, LA, LC, LK, LR, LS, LU, LY, MA, MD, ME, MG, MK, MN, MW, MX, MY, MZ, NA, NG, NI, NO, NZ, OM, PA, PE, PG, PH, PL, PT, QA, RO, RS, RU, RW, SA, SC, SD, SE, SG, SK, SL, SM, ST, SV, SY, TH, TJ, TM, TN, TR, TT, TZ, UA, UG, US, UZ, VC, VN, ZA, ZM, ZW.

- (84) Designated States** (*unless otherwise indicated, for every kind of regional protection available*): ARIPO (BW, GH, GM, KE, LR, LS, MW, MZ, NA, RW, SD, SL, ST, SZ, TZ, UG, ZM, ZW), Eurasian (AM, AZ, BY, KG, KZ, RU, TJ, TM), European (AL, AT, BE, BG, CH, CY, CZ, DE, DK, EE, ES, FI, FR, GB, GR, HR, HU, IE, IS, IT, LT, LU, LV, MC, MK, MT, NL, NO, PL, PT, RO, RS, SE, SI, SK, SM, TR), OAPI (BF, BJ, CF, CG, CI, CM, GA, GN, GQ, GW, KM, ML, MR, NE, SN, TD, TG).

Published:

- *with international search report (Art. 21(3))*
- *before the expiration of the time limit for amending the claims and to be republished in the event of receipt of amendments (Rule 48.2(h))*

(88) Date of publication of the international search report:

05 March 2020 (05.03.2020)

INTERNATIONAL SEARCH REPORT

International application No.

PCT/IL 19/50741

A. CLASSIFICATION OF SUBJECT MATTER

IPC - C07H 21/02; C12Q 1/68 (2019.01)

CPC - C12Q 1/6883; C12Q 2600/118; C12Q 2600/158

According to International Patent Classification (IPC) or to both national classification and IPC

B. FIELDS SEARCHED

Minimum documentation searched (classification system followed by classification symbols)

See Search History document

Documentation searched other than minimum documentation to the extent that such documents are included in the fields searched

See Search History document

Electronic data base consulted during the international search (name of data base and, where practicable, search terms used)

See Search History document

C. DOCUMENTS CONSIDERED TO BE RELEVANT

Category*	Citation of document, with indication, where appropriate, of the relevant passages	Relevant to claim No.
Y	US 2018/0099276 A1 (Boehringer Ingelheim Vetmca GmbH); 12 April 2018 (12.04.2018) Abstract, Figures 1-2; para [00307], para [0002], para [0047], para [00281], para [0062], para [0073], para [00125], para [0086], para [00134] and entire document	1-4
Y	US 2010/0062454 A1 (Kido et al.) 11 March 2010 (11.03.2010), Abstract; para [0003], para [0012], para [0031]	1-4
P/Y	WO 2018/122856 A1 (Hodko et al) 5 July 2018 (05.07.2018) Abstract; para [0016]-[0020]	1-4
P/Y	WO 2018/122852 A1 (Schnell), 5 July 2018 (05.07.2018) Abstract, pg 2-7	1-4
Y	WO 2018/065116 A1 (Boehringer Ingelheim Vetmca GmbH); 12 April 2018 (12.04.2018); pg 3 In 20 - pg 8 In 5; figure 1	1-4

 Further documents are listed in the continuation of Box C. See patent family annex.

* Special categories of cited documents:

"A" document defining the general state of the art which is not considered to be of particular relevance

"D" document cited by the applicant in the international application

"E" earlier application or patent but published on or after the international filing date

"L" document which may throw doubts on priority claim(s) or which is cited to establish the publication date of another citation or other special reason (as specified)

"O" document referring to an oral disclosure, use, exhibition or other means

"P" document published prior to the international filing date but later than the priority date claimed

"T" later document published after the international filing date or priority date and not in conflict with the application but cited to understand the principle or theory underlying the invention

"X" document of particular relevance; the claimed invention cannot be considered novel or cannot be considered to involve an inventive step when the document is taken alone

"Y" document of particular relevance; the claimed invention cannot be considered to involve an inventive step when the document is combined with one or more other such documents, such combination being obvious to a person skilled in the art

"&" document member of the same patent family

Date of the actual completion of the international search

2 January 2020

Date of mailing of the international search report

21 JAN 2020

Name and mailing address of the ISA/US

Mail Stop PCT, Attn: ISA/US, Commissioner for Patents

P.O. Box 1450, Alexandria, Virginia 22313-1450

Facsimile No. 571-273-8300

Authorized officer

Lee Young

Telephone No. PCT Helpdesk: 571-272-4300

INTERNATIONAL SEARCH REPORT

International application No.

PCT/IL 19/50741

Box No. II Observations where certain claims were found unsearchable (Continuation of item 2 of first sheet)

This international search report has not been established in respect of certain claims under Article 17(2)(a) for the following reasons:

- 1. Claims Nos.:
because they relate to subject matter not required to be searched by this Authority, namely:

- 2. Claims Nos.:
because they relate to parts of the international application that do not comply with the prescribed requirements to such an extent that no meaningful international search can be carried out, specifically:

- 3. Claims Nos.: 5-50, 58-80, 84-100, 107-180, 190-194
because they are dependent claims and are not drafted in accordance with the second and third sentences of Rule 6.4(a).

Box No. III Observations where unity of invention is lacking (Continuation of item 3 of first sheet)

This International Searching Authority found multiple inventions in this international application, as follows:

----- see supplemental box -----

- 1. As all required additional search fees were timely paid by the applicant, this international search report covers all searchable claims.
- 2. As all searchable claims could be searched without effort justifying additional fees, this Authority did not invite payment of additional fees.
- 3. As only some of the required additional search fees were timely paid by the applicant, this international search report covers only those claims for which fees were paid, specifically claims Nos.:

- 4. No required additional search fees were timely paid by the applicant. Consequently, this international search report is restricted to the invention first mentioned in the claims: it is covered by claims Nos.:
1-4

Remark on Protest

- The additional search fees were accompanied by the applicant's protest and, where applicable, the payment of a protest fee.
- The additional search fees were accompanied by the applicant's protest but the applicable protest fee was not paid within the time limit specified in the invitation.
- No protest accompanied the payment of additional search fees.

-----continued from Box III-----

This application contains the following inventions or groups of inventions which are not so linked as to form a single general inventive concept under PCT Rule 13.1. In order for all inventions to be searched, the appropriate additional search fees must be paid.

Group I: Claims 1-4 is directed towards a computerized automated diagnostic system comprising: a cartridge configured to contain reagents for carrying out a diagnostic biological process and to receive a biological sample to be tested using said reagents; and an instrument operative to interact with said cartridge to carry out multiple steps in said diagnostic biological process. said cartridge having multiple operative states including: a non-functionalized state in which said cartridge does not include said reagents and does not include said biological sample; a partially functionalized state in which said cartridge does include said reagents and does include said biological sample and in which a carbon array assembly is mounted onto said cartridge and forms part of said cartridge; and a fully functionalized state upon insertion of said cartridge, onto which said carbon array assembly is mounted, into clamped engagement with said instrument.

Group II: Claims 51-57 is directed towards for use in a computerized automated diagnostic system, a cartridge for carrying out a diagnostic biological process on a biological sample to be tested, said cartridge comprising a Polymerase Chain Reaction (PCR) array, said PCR array including: a plurality of aliquot chambers receiving purified sample nucleic acid material; a plurality of different dry reagent plugs, each in liquid communication with one of said plurality of aliquot chambers; a plurality of PCR chambers, each in liquid communication with one of said plurality of different dry reagent plugs; and a plurality of gas springs, each in liquid communication with one of said plurality of PCR chambers, said plurality of PCR chambers being located adjacent an edge of said cartridge.

Group III: Claims 81-83 is directed towards For use in a computerized automated diagnostic system, a cartridge for carrying out a diagnostic biological process on a biological sample to be tested, said cartridge comprising a room-temperature shelf-storable electrophoretic array, said room-temperature shelf-storable electrophoretic array including: a multiplicity of immobilized, mutually spaced and mutually electrically separated microgel deposits, each of said multiplicity of immobilized, mutually spaced and mutually electrically separated microgel deposits containing materials suitable for performing rolling circle amplification and binding of at least one of said multiplicity of pre-selected nucleic acid target molecules, each of said microgel deposits containing at least the following elements pre-anchored therein: an RCA probe specific to of at least one of said multiplicity of preselected nucleic acid target molecules; and at least one primer.

Group IV: Claims 101-106 is directed towards an automated diagnostic instrument suitable for use with a cartridge to perform computerized automatic in-vitro molecular diagnostics, the instrument comprising: a cartridge holder assembly; at least one cartridge insertion drive assembly; at least one cartridge clamping side assembly; a cartridge clamping drive assembly; cartridge actuation assembly, said cartridge actuation assembly comprising: a plurality of valve pins configured to be selectively linearly displaced parallel to a pin displacement axis in order to open and close valves within the cartridge; a plurality of valve pin linear driving motors, each valve pin linear driving motor corresponding to and being configured to drive one of said plurality of valve pins, said plurality of valve pin linear driving motors comprising first and second arrays of valve pin linear driving motors, said arrays being arranged in first and IO second planes extending generally perpendicularly to said pin displacement axis, said first plane lying above said second plane and said valve pin linear driving motors of said first and second arrays in said first and second planes being mutually offset from each other, and an optical assembly.

Group V: Claims 181-189 is directed towards a method for constructing a carbon array subassembly useful in a computerized automated diagnostic system, the method comprising: forming registration apertures in a double-sided adhesive layer; and forming liquid inlet apertures and liquid outlet apertures in said double-sided adhesive layer.

The inventions listed as Groups I-III do not relate to a single general inventive concept under PCT Rule 13.1 because, under PCT Rule 13.2, they lack the same or corresponding special technical features for the following reasons:

Special Technical Features

Group I requires said cartridge having multiple operative states including: a non-functionalized state in which said cartridge does not include said reagents and does not include said biological sample; a partially functionalized state in which said cartridge does include said reagents and does include said biological sample and in which a carbon array assembly is mounted onto said cartridge and forms part of said cartridge; and a fully functionalized state upon insertion of said cartridge, onto which said carbon array assembly is mounted, into clamped engagement with said instrument, not required by groups II-V.

Group II requires said cartridge comprising a Polymerase Chain Reaction (PCR) array, said PCR array including: a plurality of aliquot chambers receiving purified sample nucleic acid material; a plurality of different dry reagent plugs, each in liquid communication with one of said plurality of aliquot chambers; a plurality of PCR chambers, each in liquid communication with one of said plurality of different dry reagent plugs; and a plurality of gas springs, each in liquid communication with one of said plurality of PCR chambers, said plurality of PCR chambers being located adjacent an edge of said cartridge, not required by groups I and III- V.

Group III requires said cartridge comprising a room-temperature shelf-storable electrophoretic array, said room-temperature shelf-storable electrophoretic array including: a multiplicity of immobilized, mutually spaced and mutually electrically separated microgel deposits, each of said multiplicity of immobilized, mutually spaced and mutually electrically separated microgel deposits containing materials suitable for performing rolling circle amplification and binding of at least one of said multiplicity of pre-selected nucleic acid target molecules, each of said microgel deposits containing at least the following elements pre-anchored therein: an RCA probe specific to of at least one of said multiplicity of preselected nucleic acid target molecules; and at least one primer, not required by groups I and II and IV and V.

-----continued in Box below-----

-----continued from Box above-----

Group IV requires a cartridge holder assembly; at least one cartridge insertion drive assembly; at least one cartridge clamping side assembly; a cartridge clamping drive assembly; cartridge actuation assembly, said cartridge actuation assembly comprising: a plurality of valve pins configured to be selectively linearly displaced parallel to a pin displacement axis in order to open and close valves within the cartridge; a plurality of valve pin linear driving motors, each valve pin linear driving motor corresponding to and being configured to drive one of said plurality of valve pins, said plurality of valve pin linear driving motors comprising first and second arrays of valve pin linear driving motors, said arrays being arranged in first and IO second planes extending generally perpendicularly to said pin displacement axis, said first plane lying above said second plane and said valve pin linear driving motors of said first and second arrays in said first and second planes being mutually offset from each other, and an optical assembly, not required by Groups I-III and V.

Group V requires a method for constructing a carbon array subassembly useful in a computerized automated diagnostic system, the method comprising: forming registration apertures in a double-sided adhesive layer; and forming liquid inlet apertures and liquid outlet apertures in said double-sided adhesive layer, not required by Groups I-IV.

Shared Technical Features:

Groups I-IV share the common feature of a computerized automated diagnostic system comprising: a cartridge. However, these shared technical features do not represent a contribution over prior art, because the shared technical feature is anticipated by US 2013/0140177 A1 to Edan Diagnostics (hereinafter Edan). Edan discloses a computerized (para [0127], Each board may also include one or more memory devices. The memory of each board may be one or more devices (e.g., RAM, ROM, Flash memory, hard disk storage, etc.) for storing data and/or computer code for completing and/or facilitating the various processes described herein) automated (para [0087], automated mechanism) diagnostic system (para [0005], diagnostic system) comprising: a cartridge (para [0005], diagnostic system includes a removable assay cartridge).

Groups I and V share the technical feature of a carbon array subassembly useful in a computerized automated diagnostic system. However, these shared technical features do not represent a contribution over prior art, because the shared technical feature is anticipated by US 2010/0062454 A1 to Kido et al.(hereinafter Kido). Kido discloses a carbon array subassembly useful in a computerized automated diagnostic system (para [0003], method for predicting the risk of acquiring influenza, which is characterized by low price, low invasiveness, and applicability to total automation) that has a carbon array subassembly (para [0012], carbon protein arrays).

As the shared technical features were known in the art at the time of the invention, they cannot be considered special technical features that would otherwise unify the groups. Therefore, Groups I-V lack unity under PCT Rule 13.

Note : Claims 5-50, 58-80, 84-100, 107-180, 190-194 are unsearchable because they are dependent claims and are not drafted in accordance with the second and third sentences of Rule 6.4(a).