



(22) Date de dépôt/Filing Date: 2004/07/16

(41) Mise à la disp. pub./Open to Public Insp.: 2006/01/16

(45) Date de délivrance/Issue Date: 2012/01/03

(51) Cl.Int./Int.Cl. *H01R 13/62* (2006.01),
H01R 13/46 (2006.01)

(72) Inventeurs/Inventors:
NANDA, AMAR KANT, CA;
UMEDALY, MOSSADIQ, CA

(73) Propriétaire/Owner:
XANTREX TECHNOLOGY INC., US

(74) Agent: SMART & BIGGAR

(54) Titre : DISPOSITIF A CONNECTEUR ELECTRIQUE ET COUVERCLE CONNEXE

(54) Title: ELECTRICAL CONNECTOR APPARATUS AND COVER THEREFOR

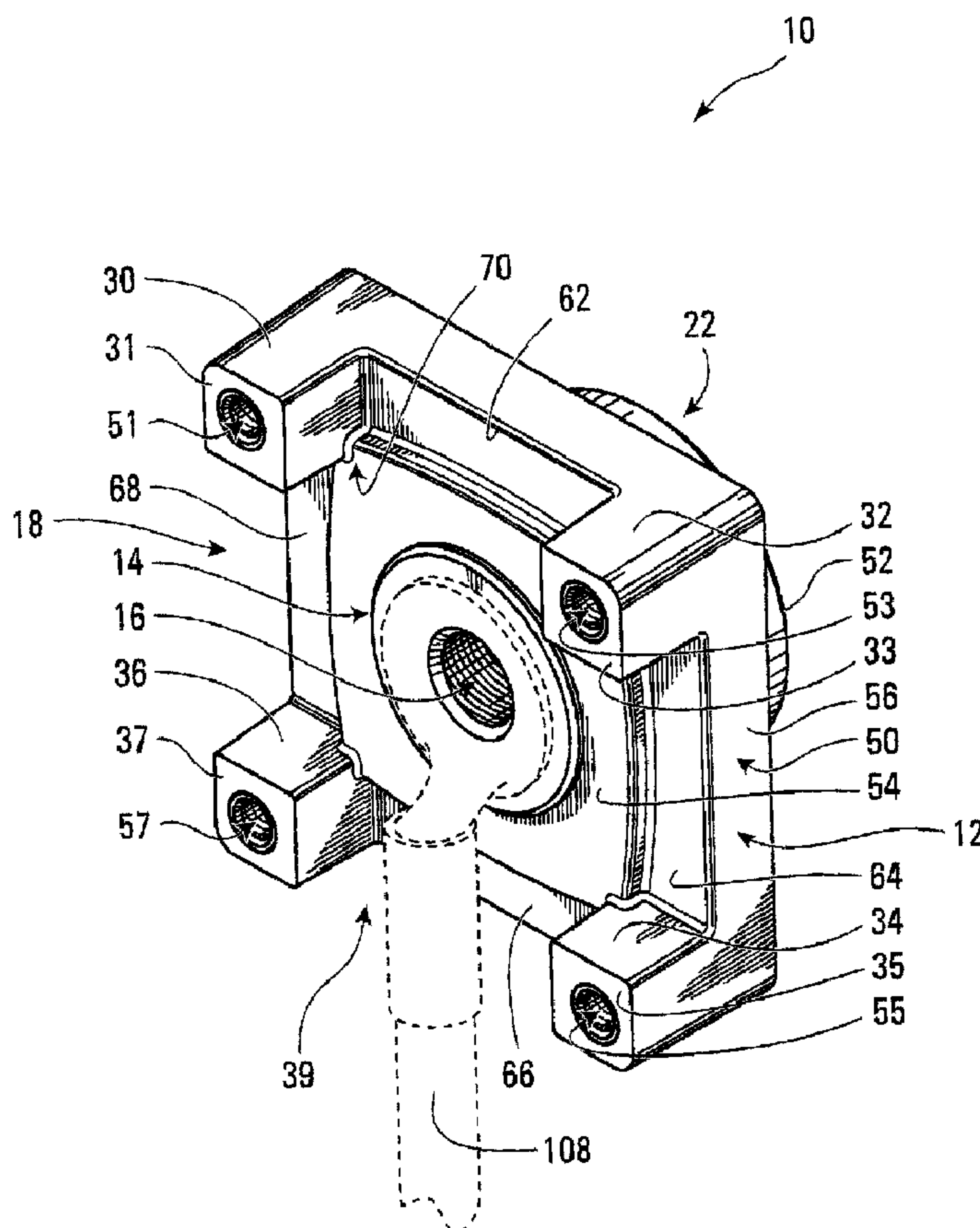

(57) Abrégé/Abstract:

An electrical connector apparatus includes an electrically insulating base, and a conductor extending through the base. The conductor may include a first electrical terminal located on a first side of the base and a second electrical terminal located on a

(57) **Abrégé(suite)/Abstract(continued):**

second side of the base. The apparatus further includes at least three spaced apart guides on the first side of the base, all of the spaced apart guides being adjacent the first electrical terminal and being operable to guide a wire terminated to the first electrical terminal to extend in any direction between two adjacent guides. A cover may be applied to the electrical connector, the cover including a housing including joined rigid wall portions configured to extend about a perimeter and over a top of an electrical terminal, at least one of the wall portions having a conductor opening. The cover apparatus further includes a conductor guard having a rigid guide wall extending from at least one of the wall portions, adjacent the conductor opening, to guard a wire terminated to the electrical terminal against small-radius bends near the electrical terminal.

ELECTRICAL CONNECTOR APPARATUS AND COVER THEREFOR**ABSTRACT**

5

An electrical connector apparatus includes an electrically insulating base, and a conductor extending through the base. The conductor may include a first electrical terminal located on a first side of the base and a second electrical terminal located on a second side of the base. The apparatus further includes at least three spaced apart guides on the first side of the base, all of the spaced apart guides being adjacent the first electrical terminal and being operable to guide a wire terminated to the first electrical terminal to extend in any direction between two adjacent guides. A cover may be applied to the electrical connector, the cover including a housing including joined rigid wall portions configured to extend about a perimeter and over a top of an electrical terminal, at least one of the wall portions having a conductor opening. The cover apparatus further includes a conductor guard having a rigid guide wall extending from at least one of the wall portions, adjacent the conductor opening, to guard a wire terminated to the electrical terminal against small-radius bends near the electrical terminal.

10

15

20

ELECTRICAL CONNECTOR APPARATUS AND COVER THEREFOR

BACKGROUND OF THE INVENTION

1. Field of Invention

5 This invention relates to electrical connector apparatus and covers therefor.

2. Description of Related Art

10 Methods for terminating an electrical conductor abound. One common method involves the use of a screw terminal. Various types of screw terminals exist including barrier-type screw terminals that employ a row of screw terminals each of which is separated from an adjacent one by a barrier. The barriers tend to define a particular direction in which a wire or crimp connector may be installed on the screw terminal. Typically they permit a crimp connector or wire to be installed in only two directions, each about 180
15 degrees apart from the other. This can be limiting, especially where high current DC cables, for example are to be connected to the screw terminal.

20 Lead acid-type batteries typically have terminals which may include a conductive disk with a threaded stud projecting therefrom. The stud however is susceptible to being broken off due to excessive tightening torque, requiring replacement of the terminal or replacement of the battery. Typically this type of terminal is molded into a battery casing and is not easily removed.

SUMMARY OF THE INVENTION

25 The present invention provides a way of fastening electrical conductors, particularly relatively high current electrical conductors to a device having an internal printed circuit board, without placing strain on the printed circuit board, while providing an easy way of mounting a connector to the device. The invention need not be employed in this specific application and may be used
30 generally anywhere a connector is required to connect one wire to another, especially on a device, where the two wires may be on opposite sides of a wall, barrier or bulkhead of the device.

In accordance with one aspect of the invention, there is provided an electrical connector apparatus. The electrical connector apparatus includes an electrically insulating base, and a conductor extending through the base. The conductor may include a first electrical terminal located on a first side of the base and a second electrical terminal located on a second side of the base. The first electrical terminal includes a first threaded opening in the conductor. The apparatus further includes at least three spaced apart guides on the first side of the base, all of the spaced apart guides being adjacent the first electrical terminal and being operable to guide a wire terminated to the first electrical terminal to extend in any direction between two adjacent guides.

The first and second sides of the base may be on opposite sides of the base. The second electrical terminal may include a second threaded opening in the conductor. The first and second threaded openings may be coterminous and form a threaded passageway through the conductor. The first and second threaded openings may be coaxial. The base may be molded about the conductor.

The base may include a mounting portion. The mounting portion may include a flat surface on the second side of the base. The flat surface may have threaded inserts disposed therein, for receiving fasteners for fastening the base to a device. The base may include a projection extending from the flat surface. The flat surface may have threaded inserts disposed therein and symmetrically about the projection. The flat surface may have an o-ring groove extending around the projection for receiving an o-ring for sealing the connector against a mounting surface.

The base may include a stage portion on the first side of the base. The spaced apart guides may be disposed about the stage portion. The base may include bridging surface portions extending between the guides, adjacent the stage portion. The base may include a first opening in the stage portion that

-3-

extends to a cavity in the base. The base may further include a second opening in a distal end of the projection extending to the cavity. The conductor may include a rotation preventer operable to prevent rotation of the conductor relative to the base. The rotation preventer may include a flat surface on the conductor. The rotation preventer may be in the cavity.

The conductor may have first and second end portions with first and second distal surfaces respectively, and a length, measured between the first and second distal surfaces, that is slightly longer than the bore such that the first and second end portions project slightly beyond the distal ends of the projection and the stage portion.

The conductor may have first and second coterminous openings in the first and second distal surfaces respectively, forming a passageway through the conductor. The first and second coterminous openings and the passageway may be coaxial.

The first and second coterminous openings and the passageway may be threaded for receiving first and second bolts in the first and second openings respectively, for securing connectors on respective wires to the first and second electrical terminals respectively.

The guides may have respective flat planar distal end surfaces and the flat planar distal end surfaces may be disposed at a distance from the stage portion. The flat planar distal end surfaces may be coplanar. The guides may have respective threaded inserts in respective flat planar distal end surfaces, the threaded inserts being operable to receive fasteners for fastening a cover to the base.

The apparatus may further include a cover apparatus including a housing including joined rigid wall portions configured to extend about a perimeter and over a top of an electrical terminal, at least one of the wall portions having a

-4-

conductor opening, the cover apparatus further including a conductor guard comprising a rigid guide wall extending from at least one of the wall portions, adjacent the conductor opening, to guard a wire terminated to the electrical terminal against small-radius bends near the electrical terminal.

5

In accordance with another aspect of the invention, there is provided a cover apparatus for covering an electrical terminal. The cover apparatus includes a housing including joined rigid wall portions configured to extend about a perimeter and over a top of an electrical terminal, at least one of the wall portions having a conductor opening. The cover apparatus further includes a conductor guard having a rigid guide wall extending from at least one of the wall portions, adjacent the conductor opening, to guard a wire terminated to the electrical terminal against small-radius bends near the electrical terminal.

10

15

The rigid guide wall may have an outwardly flared shape.

The wall portions and the rigid guide wall may be embodied in a unitary piece of insulating material.

20

The insulating material may include plastic.

At least one of the wall portions may have a landing formed therein, the landing having an opening, for receiving a fastener for securing the cover to the electrical terminal.

25

At least one of the wall portions may be curved and may be configured to extend over the top portion of the electrical terminal.

30

At least one of the wall portions may be curved and may be positioned opposite the wall portion having a conductor opening.

-5-

The wall portion extending over the top portion of the electrical terminal and the wall portion positioned opposite the wall portion having the conductor opening may be joined by an angled wall portion.

5 At least one of the wall portions may have a test probe opening operable to receive a test probe to permit contacting the test probe with the electrical terminal without requiring removal of the cover from the electrical terminal.

10 At least one of the wall portions may be curved and may be configured to extend over the top portion of the electrical terminal and may have a test probe opening operable to receive a test probe to permit contacting the test probe with the electrical terminal without requiring removal of the cover from the electrical terminal.

15 The wall portions configured to extend about a perimeter the electrical terminal may have edges that lie in a common plane. The rigid guide wall may be generally U-shaped and may have first and second leg portions having edges lying in the common plane. The rigid guide wall may include a curved joining portion joining the first and second leg portions, the curved joining
20 portion having a radius of curvature becoming progressively larger progressively farther away from the housing.

25 Other aspects and features of the present invention will become apparent to those ordinarily skilled in the art upon review of the following description of specific embodiments of the invention in conjunction with the accompanying figures.

BRIEF DESCRIPTION OF THE DRAWINGS

In drawings which illustrate embodiments of the invention,

30

Figure 1 is a perspective view of an electrical connector apparatus according to a first embodiment of the invention;

- Figure 2 is a plan view of a first side of the electrical connector apparatus shown in Figure 1;
- 5 Figure 3 is a top view of the electrical connector apparatus shown in Figure 1;
- Figure 4 is a side elevational view of a second side of the electrical connector apparatus shown in Figure 1;
- 10 Figure 5 is a perspective view of a device on which the electrical connector apparatus shown in Figure 1 is to be installed;
- Figure 6 is a side view of the electrical connector apparatus shown in Figure 1, shown mounted on a wall of the device shown in Figure 5;
- 15 Figure 7 is a perspective view of a cover apparatus according to another embodiment of the invention;
- 20 Figure 8 is a top view of the cover apparatus shown in Figure 7;
- Figure 9 is a first side view of the cover apparatus shown in Figure 7;
- 25 Figure 10 is a bottom view of the cover apparatus shown in Figure 7;
- Figure 11 is a second side view of the cover apparatus shown in Figure 7;
- Figure 12 is a front view of the cover apparatus shown in Figure 7;
- 30 Figure 13 is a rear view of the cover apparatus shown in Figure 7.

-7-

DETAILED DESCRIPTION

Referring to Figure 1, an electrical connector apparatus according to a first embodiment of the invention is shown generally at **10**. The apparatus includes an electrically insulating base **12**, a conductor **14** extending through the base and having a first electrical terminal **16** located on a first side **18** of the base. Referring to Figure 3, the conductor **14** further includes a second electrical terminal **20** located on a second side **22** of the base **12**, opposite the first side **18**.

Referring back to Figure 1, the apparatus **10** includes at least three spaced apart guides on the first side of the base **12** and in the embodiment shown there are four spaced apart guides identified as first, second, third and fourth guides **30**, **32**, **34**, and **36**. All of the spaced apart guides **30**, **32**, **34**, **36** are adjacent the first electrical terminal **16** and are operable to guide a wire **108** terminated to the first electrical terminal **16** to extend in a sector **39** between two adjacent guides. Each of the guides **30**, **32**, **34** and **36** has an outer, distal surface **31**, **33**, **35** and **37**, and may be fitted with a respective threaded insert **51**, **53**, **55** and **57** in its respective distal surface. The guides confine the movement of the wire **108** connected to the first electrical terminal **16** to cause it to extend from the first electrical terminal in a direction defined between adjacent guides such as guides **34** and **36** as shown.

Referring to Figure 5, the apparatus **10** may be mounted to an outside of a device **40** such as an inverter, for example, with fasteners **41** for holding the apparatus **10** being installed from an inside area **43** of the device, so that the fasteners cannot be seen or accessed from the outside of the device.

Referring to Figures 1-4, the base **12** further includes a mounting portion **50**, a projection **52**, and a raised stage portion **54** seen best in Figures 1-3. In the embodiment shown, the mounting portion **50** includes a wall **56** having a generally rectangular outer perimeter although the outer perimeter may be

-8-

any suitable shape. The wall **56** defines the first and second opposite sides **18** and **22** of the base **12**.

5 On the first side **18** of the base **12**, the guides **30**, **32**, **34**, **36** project from the wall **56** and the wall has generally coplanar bridging surface portions **62**, **64**, **66** and **68** that extend between successive guides. The raised stage portion **54** projects outwardly of the bridging surface portions **62**, **64**, **66** and **68** by about 1 mm and defines a relatively flat planar area **70** surrounded by the guides and bridging surface portions **62**, **64**, **66** and **68**. A first cylindrical opening **72** is formed in the flat planar area **70** and extends in a first direction to a cavity **71**. A second cylindrical opening **74** in a distal end **76** of the projection **52** extends in a second, opposite direction, into the cavity.

15 On the second side **22** of the base **12**, the wall **56** has a first flat mounting surface **58** having a central axis **60**. Threaded inserts **61**, **63**, **65** and **67** are installed symmetrically about the central axis **60** in the flat mounting surface **58**. The projection **52** has a cylindrical shape and extends outwardly from the first flat mounting surface **58** and is centered on the central axis **60**. The flat mounting surface **58** has an o-ring groove **59** therein for receiving an o-ring for sealing the connector against a mounting surface of a device such as device **40**.

25 In the embodiment shown, the conductor **14** is provided by a brass member that extends through the base **12**, from the first side **18** to the second side **22**. The conductor **14** has a section **78** having a rotation preventer, which in the embodiment shown includes at least one flat surface **79** that is received in the cavity **71** to hold it against rotation relative to the base **12**. The conductor **14** also has first and second end portions **80** and **82** extending in opposite directions from the section **78**. In the embodiment shown, the section **78** has a flat surface **79** to prevent relative rotation between the conductor **14** and the base **12**. In general, any method of preventing such relative rotation would work, including simple projections extending from the conductor **14** into the

-9-

base **12** or flat surfaces on portions of the end portions **80** and **82** that are embedded within the base, for example. It will be appreciated that the cavity **71** and openings **72** and **74** need not be pre-formed in the base **12**, but rather may be formed by molding the base around the conductor **14**. Pre-forming of the cavity **71** and openings **72** and **74** may be required where the base is formed in two halves that are joined together about the conductor **14**, for example.

The first and second end portions **80** and **82** of the conductor **14** are dimensional to project slightly beyond a distal surface of the raised stage portion **54** and a distal surface of the projection **52**. The first and second end portions **80** and **82** have first and second generally flat distal surfaces **86** and **88** respectively. In the embodiment shown the first and second generally flat distal surfaces **86** and **88** have first and second coterminous, coaxial openings **90** and **92** respectively forming a passageway **94** formed along an axis of symmetry **96** of the conductor **14** coincident with the central axis **60**. Referring to Figure 6, in the embodiment shown, the first and second openings **90** and **92** and passageway **94** are threaded for receiving first and second bolts **100** and **102** in the first and second openings **90** and **92** respectively, for securing crimp connectors **104** and **106**, to which respective external and internal wires **108** and **110** may be attached to the opposite ends of the conductor **14**. The first and second openings **90** and **92** and surrounding first and second generally flat distal surfaces **86** and **88** respectively act as the first and second electrical terminals **16** and **20** respectively.

Referring to Figure 5, in use, a device **40** on which the apparatus **10** is to be used is configured to include a circular opening **120** having a diameter slightly larger than the diameter of the projection **52**. Additional openings such as opening **122** are formed in a wall **124** of the device **40** to facilitate receiving fasteners **41** such as screws therein to permit the fasteners **41** to engage with the threaded inserts **61**, **63**, **65** and **67** in the mounting surface **58**. The

-10-

apparatus **10** is mounted to the device **40** such that the projection **52** projects inwardly into the device through the opening **120** and such that the fasteners **41** are inserted into the openings **122** from inside the device **40**. This ensures that the apparatus cannot be easily removed from the device **40** without opening it up. Referring to Figure **6**, when the apparatus **10** is mounted to the device **40**, the o-ring **71** seals the connector against the wall **124** of the device, thus making the device usable for both indoor and outdoor applications. A wire **110** internal to the device, from a circuit such as an inverter circuit inside the device may be connected to the second electrical terminal **20** by engagement of the second bolt **102** with a ring of a crimp connector **106** on the wire and by engagement of the second bolt **102** with the threads in the second opening **92**. The conductor **14** is thus electrically connected to the wire **110**.

The guides **30**, **32**, **34** and **36** project outwardly, generally normal to the surface of the wall **124** of the device **40**. An external wire **108**, such as from a battery, for example, may be connected to the first electrical terminal **16** by engagement of the first bolt **100** with a ring of a first crimp connector **104** on the external wire **108** and engaging the threads on the first bolt with the threads in the first opening **90**. The external wire **108** is thus electrically connected to the first electrical terminal **16** and is connected to the first terminal through the conductor **14**. As the first bolt **100** is tightened in the first opening **90**, the high torque forces involved as the bolt is tightened may have a tendency to rotate the crimp connector **104** about the central axis **60**. The guides adjacent the crimp connector **104**, only one of which is shown at **36** in Figure **6**, limit the range of rotation of the crimp connector to only a small sector, thus permitting the external wire **108** to extend from the connector generally radially, in a generally well-defined direction. The raised stage portion **54** and protruding generally flat distal surface **86** of the conductor **14** ensure a good, maximum surface area contact between the crimp connector **104** and the protruding generally flat distal surface **86** and provide clearance between the crimp connector **104** and the bridging surface portions **62**, **64**, **66**

-11-

and **68** to avoid deforming the crimp connector **104** when the first bolt **100** is fully tightened in the first opening **90**. A similar advantage is achieved at the second electrical terminal **20** due to the second end portion **82** of the conductor **14** projecting slightly beyond the end of the projection **52**.

5

Additional wires may be connected to the first electrical terminal **16** by overlaying crimp connectors connected to respective such wires so that respective rings of the crimp connectors are axially aligned to receive the first bolt **100**, and by securing the bolt with the crimp connectors thereon to the first opening **90**. Respective wires may be arranged to extend between respective pairs of guides **30**, **32**, **34** and **36** such that each wire extends generally radially from the opening in a sector determined by the spacing of the respective pair of guides and the width (diameter) of the crimp portion of the respective crimp connector.

10

15

Referring to Figure 7, in accordance with another aspect of the invention, there is provided a cover apparatus **150**, in accordance with one embodiment of the invention, for covering an electrical connector apparatus such as the one described above. In the embodiment shown the cover apparatus **150** includes a main housing **151** comprised of first **152**, second **154**, third **156**, fourth **158**, fifth **160** and sixth **162** joined rigid wall portions configured to extend about the perimeter and top of the base of the electrical connector apparatus **10** described above. The first, second, third and fourth wall portions **152**, **154**, **156** and **158** have respective edges **172**, **174**, **176** and **178** each having an edge surface lying in a common plane. In use, when the cover apparatus **150** is installed on the connector apparatus **10**, the common plane would be coincident with a mounting surface on a wall such as wall **124** the device **40**, or spaced apart slightly therefrom.

20

25

30

At least one of the wall portions has a conductor opening **180** and in the embodiment shown, the conductor opening is in the third wall portion **156**. The cover apparatus **150** further includes a conductor guard **190** comprising a

-12-

rigid guide wall **192** extending outwardly of the third wall portion **156**, adjacent the conductor opening **180**, to guard a wire terminated to the connector apparatus **10** described above against small-radius bends near the connector apparatus.

5

In the embodiment shown, the wall portions **152**, **154**, **156**, **158**, **160** and **162** and the rigid guide wall **192** are embodied in a unitary piece of electrically insulating material such as hard plastic.

10

The first and second side wall portions **152** and **154** are generally flat. The third wall portion **156** is generally flat with the rigid guide wall **192** extending therefrom. The fourth wall portion **158**, disposed opposite the third wall portion **156** is convexly curved. Thus, the wall portion on a side of the cover opposite to the side from which the rigid guide wall extends is convexly

15

curved. The sixth wall portion **162** extending over the top portion of the electrical terminal is curved and joins the first, second and third side wall portions **152**, **154** and **156**. The fifth wall portion **160** extends between the fourth wall portion **158** and the fifth wall portion **160** and joins each of these wall portions such that it extends at an angle relative to the common plane in which the edges **172**, **174**, **176** and **178** lie.

20

25

At least one of the wall portions has a test probe opening **179** operable to receive a test probe to permit the test probe to contact the electrical terminal without requiring removal of the cover therefrom. In the embodiment shown, the test probe opening **179** is in the sixth wall portion **162**.

30

In the embodiment shown, the rigid guide wall **192** is generally U-shaped having first and second leg portions **194** and **196** and a curved joining portion **197** joining the first and second leg portions **194** and **196**. The first and second leg portions **194** and **196** are terminated in respective coplanar edges

-13-

198 and **200** that are coplanar with the edges **172**, **174**, **176**, and **178** of the main housing **151**. The first and second leg portions **194** and **196** also have distal portions **202** and **204** terminated in a single continuous distal edge **206** that defines an access opening **208** through which a wire connected to the connector apparatus **10** housed by the cover apparatus **150** may extend. The rigid guide wall **192** is configured such that the first and second leg portions **194** and **196** become progressively longer, progressively farther away from the third wall portion **156**, and such that the radius of curvature of the joining portion **197** becomes progressively larger such that the access opening **208** is slightly larger than the conductor opening **180** in the third wall portion **156**. The rigid guide wall **192** thus has an outwardly flared shape. This reduces any chance of cutting insulation on a wire extending into the housing due to rubbing of the insulation on the distal edge **206**.

In the embodiment shown, the first and second wall portions **152** and **154** have first and second landings **220** and **222** formed at right angles therein, to align with corresponding fastener openings in an electrical connector with which the cover apparatus **150** is to be used. In the embodiment shown, the first and second landings **220** and **222** align with corresponding threaded inserts **51**, **53**, **55** and **57** in the guides **30**, **32**, **34** and **36** of the connector apparatus **10** described above. The landings **220** and **222** have first and second openings **224** and **226** respectively therein for receiving a fastener (not shown) for fastening the cover apparatus **150** to the connector apparatus **10**. The sixth wall portion **162** has first and second recessed areas **228** and **230** adjacent the first and second landings **220** and **222** respectively, facilitating application of a tool such as a screw driver to fasteners received in the first and second openings **224** and **226**. In the embodiment shown, the threaded inserts **51**, **53**, **55** and **57** in the guides **30**, **32**, **34** and **36** are arranged symmetrically at a common distance from the central axis **60**. Similarly, the first and second landings **220** and **222** and first and second openings **224** and **226** are arranged symmetrically about an axis of the cover at distances similar to those of the threaded inserts. Consequently, the cover

-14-

apparatus **150** may be placed on the connector apparatus **10** at one of four orientations, allowing the cover apparatus to permit a wire connected to the connector apparatus to extend in any of four directions from the connector apparatus. Similar symmetrical connector and cover arrangements could be made with other connectors having three or more guides and correspondingly shaped covers.

5

Different cover apparatuses of the type described may be colored red and black, for example and used on positive and negative terminals on the device **40**, for example.

10

While specific embodiments of the invention have been described and illustrated, such embodiments should be considered illustrative of the invention only and not as limiting the invention as construed in accordance with the accompanying claims.

15

-15-

THE EMBODIMENTS OF THE INVENTION IN WHICH AN EXCLUSIVE PROPERTY OR PRIVILEGE IS CLAIMED ARE DEFINED AS FOLLOWS:

1. An electrical connector apparatus comprising:
 - 5 an electrically insulating base;
 - a conductor extending through said base said conductor comprising a first electrical terminal located on a first side of
10 said base and a second electrical terminal located on a second side of said base, said first electrical terminal comprising a first threaded opening in said conductor; and
 - at least three spaced apart guides on said first side of said
15 base, all of said spaced apart guides being adjacent said first electrical terminal and being operable to guide a wire terminated to said first electrical terminal to extend in any direction between two adjacent said guides.
- 20 2. The apparatus of claim 1 wherein said first and second sides of said base are on opposite sides of said base.
3. The apparatus of claim 1 wherein said second electrical terminal
25 comprises a second threaded opening in said conductor.
4. The apparatus of claim 3 wherein said first and second threaded openings are coterminous and form a threaded passageway through said conductor.
- 30 5. The apparatus of claim 3 wherein said first and second threaded openings are coaxial.

-16-

6. The apparatus of claim 5 wherein said base is molded about said conductor.
- 5 7. The apparatus of claim 1 wherein said base includes a mounting portion.
8. The apparatus of claim 7 wherein said mounting portion includes a flat surface on said second side of said base.
- 10 9. The apparatus of claim 8 wherein said flat surface has threaded inserts disposed therein, for receiving fasteners for fastening said base to a device.
- 15 10. The apparatus of claim 10 wherein said base includes a projection extending from said flat surface.
11. The apparatus of claim 10 wherein said flat surface has threaded inserts disposed therein symmetrically about said projection.
- 20 12. The apparatus of claim 10 wherein said flat surface has an o-ring groove therein, the o-ring groove extending around said projection.
13. The apparatus of claim 10 wherein said base includes a stage portion on said first side of said base.
- 25 14. The apparatus of claim 13 wherein said at least three spaced apart guides are disposed about said stage portion.
- 30 15. The apparatus of claim 14 wherein said base includes bridging surface portions extending between said guides, adjacent said stage portion.

-17-

- 5
16. The apparatus of claim 15 wherein said base includes a first opening in said staging portion that extends to a second coterminous opening in a distal end of said projection forming a bore extending through said base, said bore being operable to hold said conductor therein.
- 10
17. The apparatus of claim 16 wherein said conductor has first and second end portions with first and second distal surfaces respectively, and a length, measured between said first and second distal surfaces, that is slightly longer than said bore such that said first and second end portions project slightly beyond the distal end of said projection and the staging portion.
- 15
18. The apparatus of claim 17 wherein said conductor includes a rotation preventer operable to prevent rotation of the conductor relative to the base.
19. The apparatus of claim 18 wherein said rotation preventer includes a flat surface on said conductor.
- 20
20. The apparatus of claim 17 wherein said conductor has first and second coterminous openings in said first and second distal surfaces respectively, forming a passageway through said conductor.
- 25
21. The apparatus of claim 17 wherein said first and second coterminous openings and said passageway are coaxial.
- 30
22. The apparatus of claim 20 wherein said first and second coterminous openings and said passageway are threaded for receiving first and second bolts in said first and second openings respectively, for securing connectors on respective wires to said first and second electrical terminals respectively.

-18-

23. The apparatus of claim 1 wherein said guides have respective flat planar distal end surfaces.
- 5 24. The apparatus of claim 12 wherein said guides have respective flat planar distal end surfaces and wherein said flat planar distal end surfaces are disposed at a distance from said staging portion.
- 10 25. The apparatus of claim 24 wherein said flat planar distal end surfaces are coplanar.
- 15 26. The apparatus of claim 24 wherein said guides have respective threaded inserts in respective said flat planar distal end surfaces, said threaded inserts being operable to receive fasteners for fastening a cover to said base.
- 20 27. The apparatus of claim 1 further comprising a cover apparatus including a housing comprising joined rigid wall portions configured to extend about a perimeter and over a top of an electrical terminal, at least one of said wall portions having a conductor opening, and a conductor guard comprising a rigid guide wall extending from said at least one of said wall portions, adjacent said conductor opening, to guard a wire terminated to said electrical terminal against small-radius bends near said electrical terminal.
- 25 28. The apparatus of claim 27 wherein said rigid guide wall has an outwardly flared shape.
- 30 29. The apparatus of claim 27 wherein said wall portions and said rigid guide wall are embodied in a unitary piece of insulating material.
- 30 30. The apparatus of claim 29 wherein said insulating material comprises plastic.

- 5
- 10
- 15
- 20
- 25
- 30
31. The apparatus of claim 27 wherein at least one of said wall portions has a landing formed therein, said landing having an opening, for receiving a fastener.
 32. The apparatus of claim 27 wherein at least one of said wall portions is curved and is configured to extend over said top portion of the electrical terminal.
 33. The apparatus of claim 32 wherein at least one of said wall portions is curved and is positioned opposite said at least one of said wall portions having a conductor opening.
 34. The apparatus of claim 33 wherein said wall portion extending over said top portion of the electrical terminal and said wall portion positioned opposite said at least one of said wall portions having a conductor opening are joined by an angled wall portion.
 35. The apparatus of claim 27 wherein at least one of said wall portions has a test probe opening operable to receive a test probe to permit contacting the test probe with the electrical terminal without requiring removal of the cover from the electrical terminal.
 36. The apparatus of claim 27 wherein at least one of said wall portions is curved and is configured to extend over said top portion of the electrical terminal and has a test probe opening operable to receive a test probe to permit contacting the test probe with the electrical terminal without requiring removal of the cover from the electrical terminal.

-20-

- 37.** The apparatus of claim **27** wherein said wall portions configured to extend about a perimeter the electrical terminal have edges that lie in a common plane.
- 5 **38.** The apparatus of claim **37**, wherein said rigid guide wall is generally U-shaped and has first and second leg portions having edges lying in said common plane.
- 10 **39.** The apparatus of claim **38** wherein said rigid guide wall includes a curved joining portion joining the first and second leg portions, the curved joining portion having a radius of curvature becoming progressively larger progressively farther away from said housing.

+

1/8

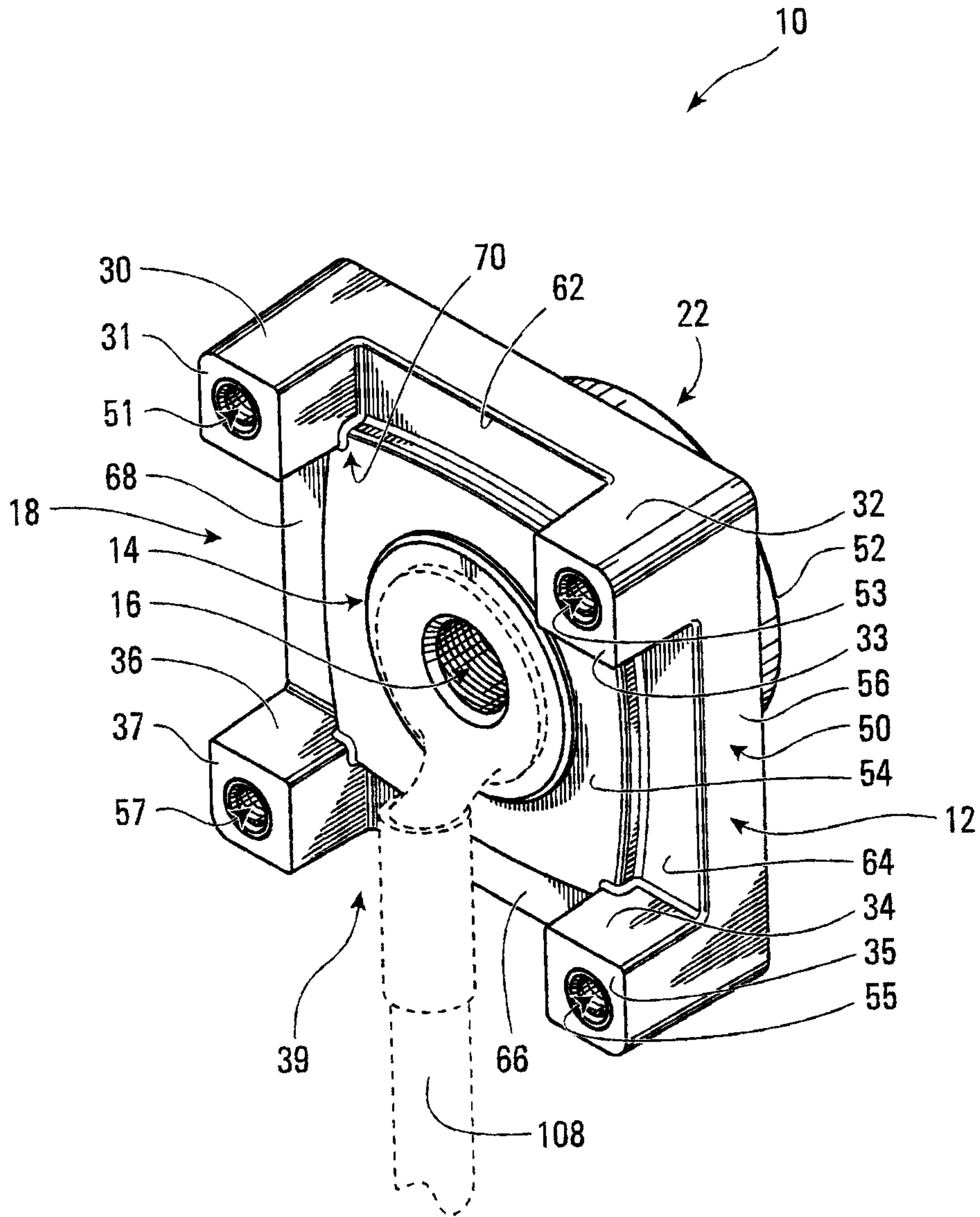

FIG. 1

+

+

2/8

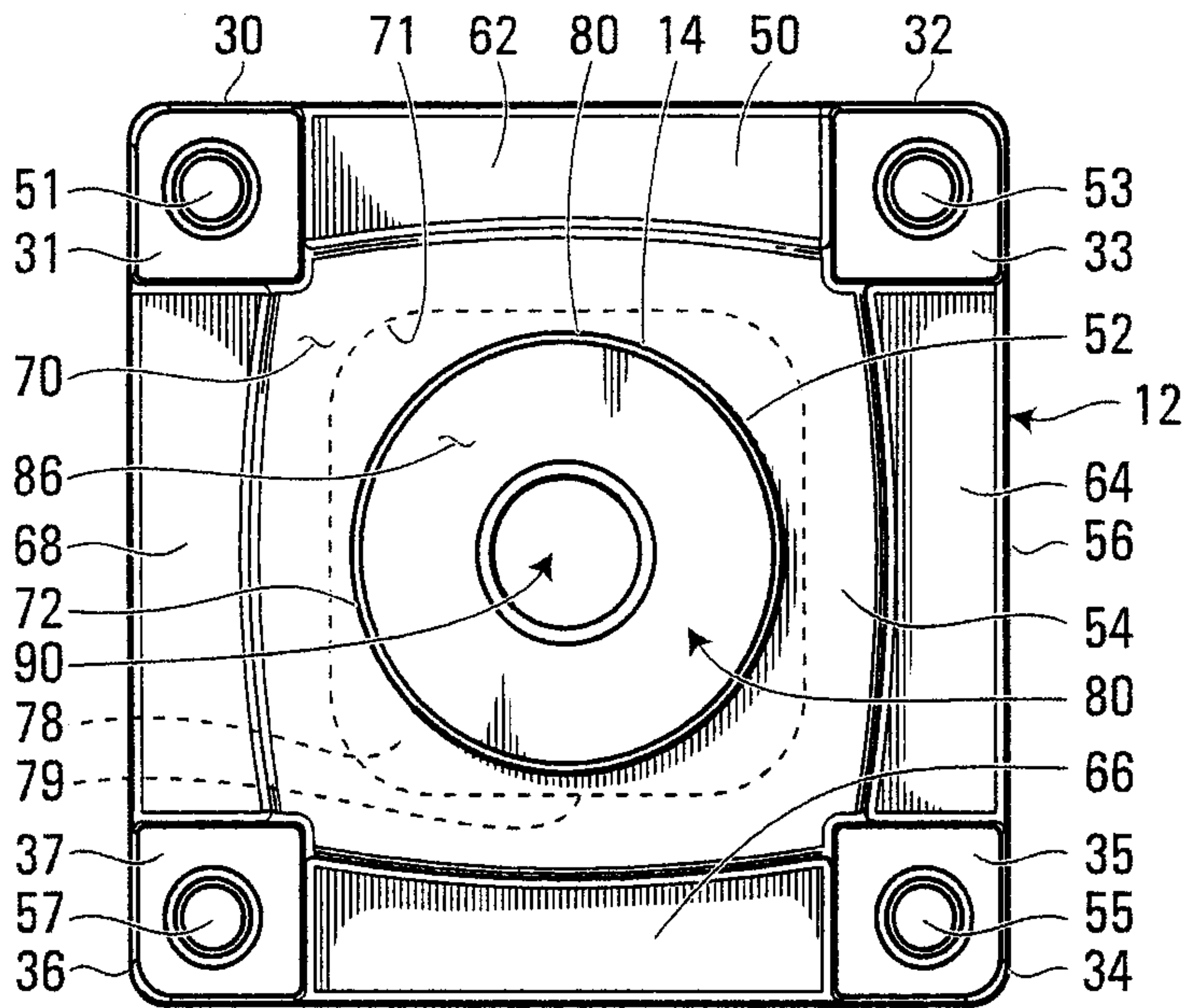

FIG. 2

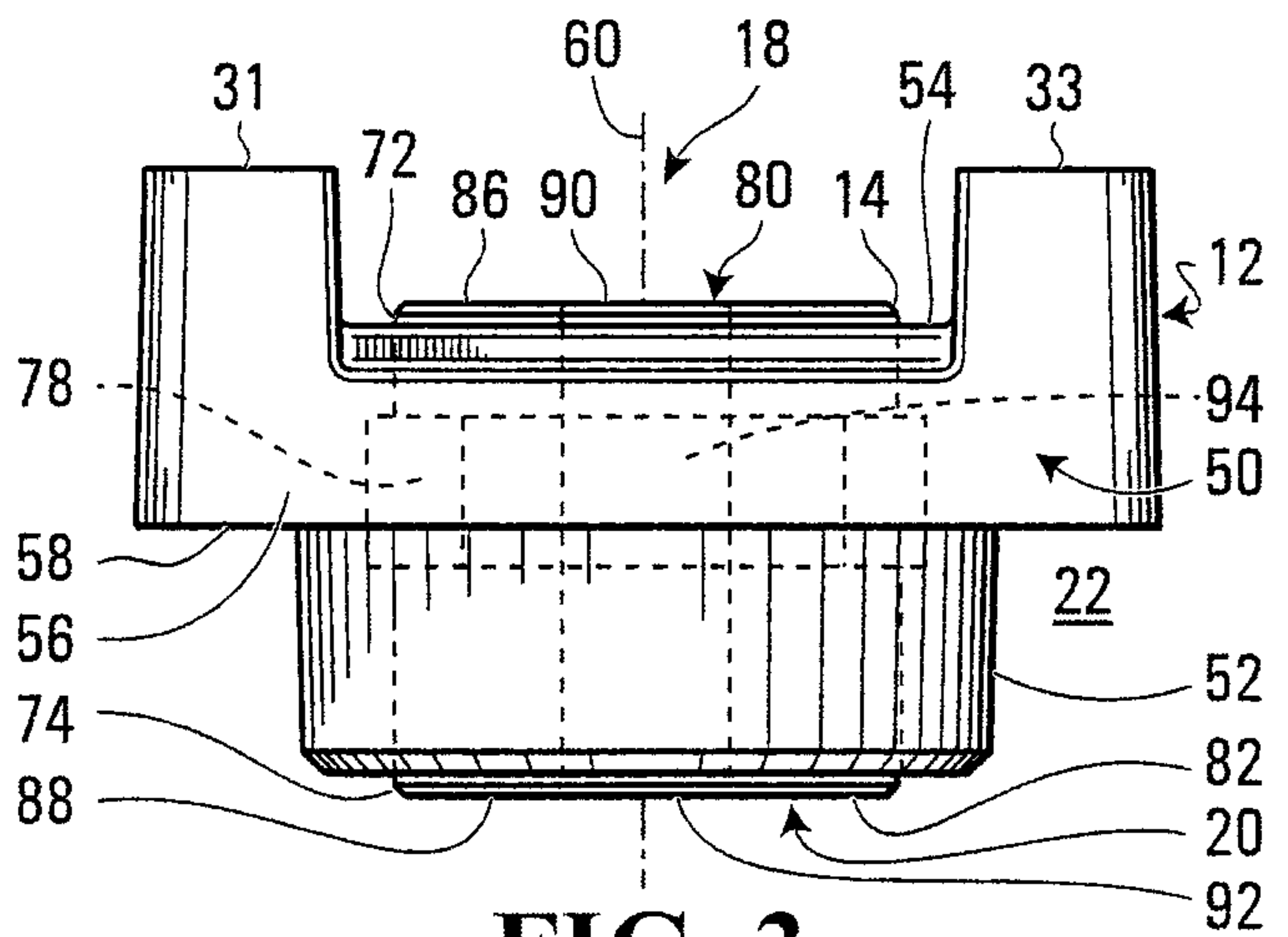

FIG. 3

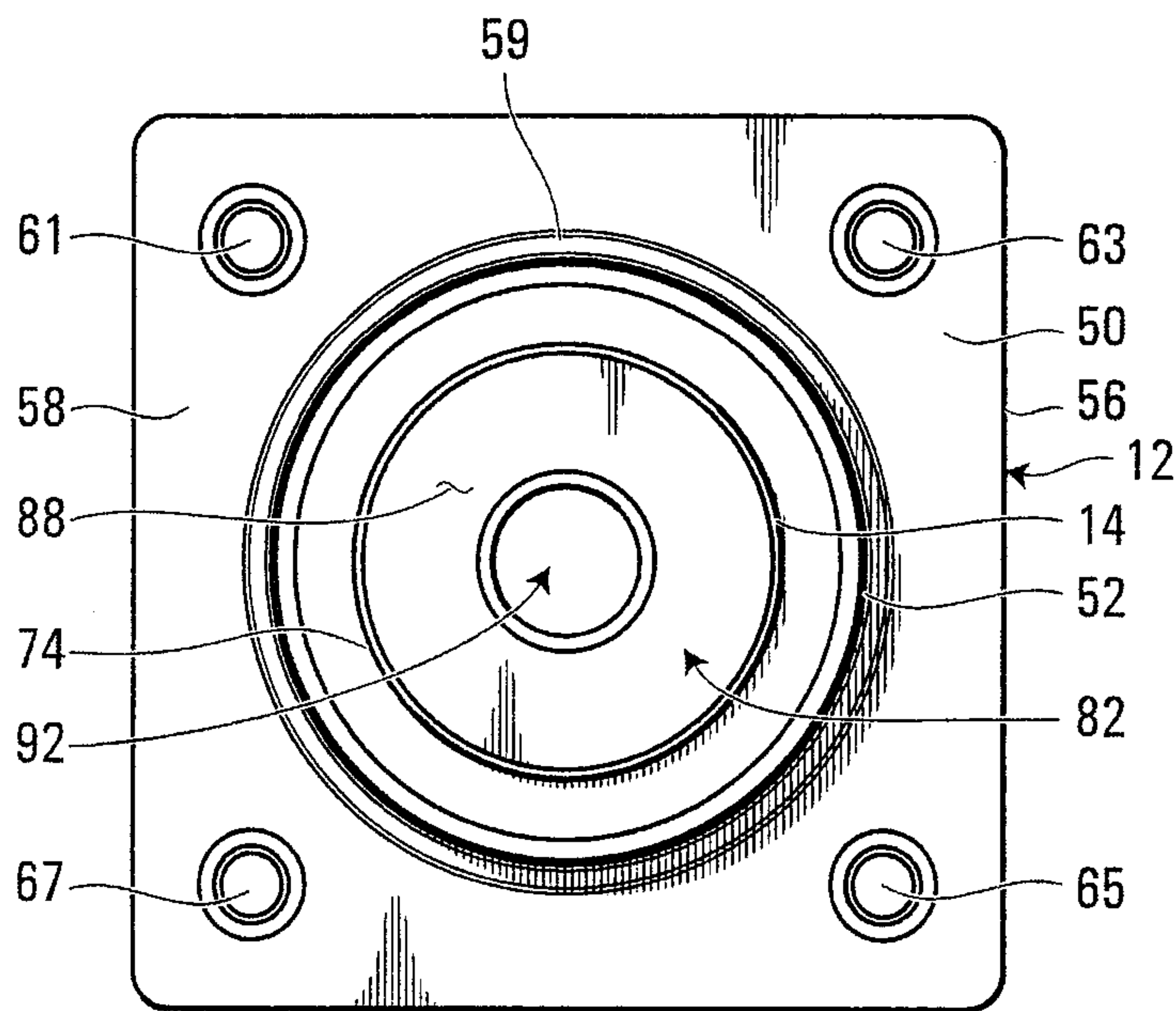

FIG. 4

+

3/8

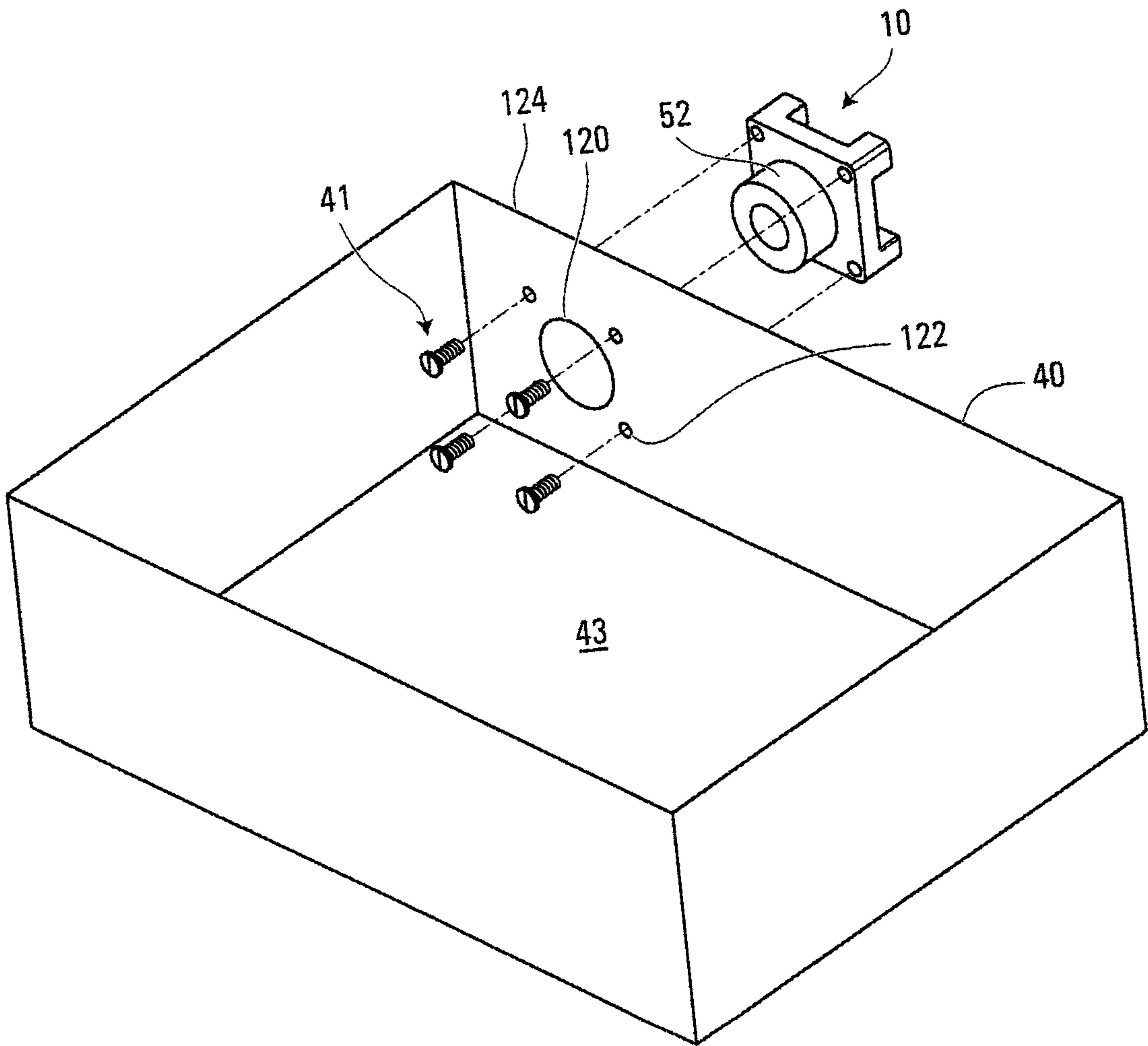

FIG. 5

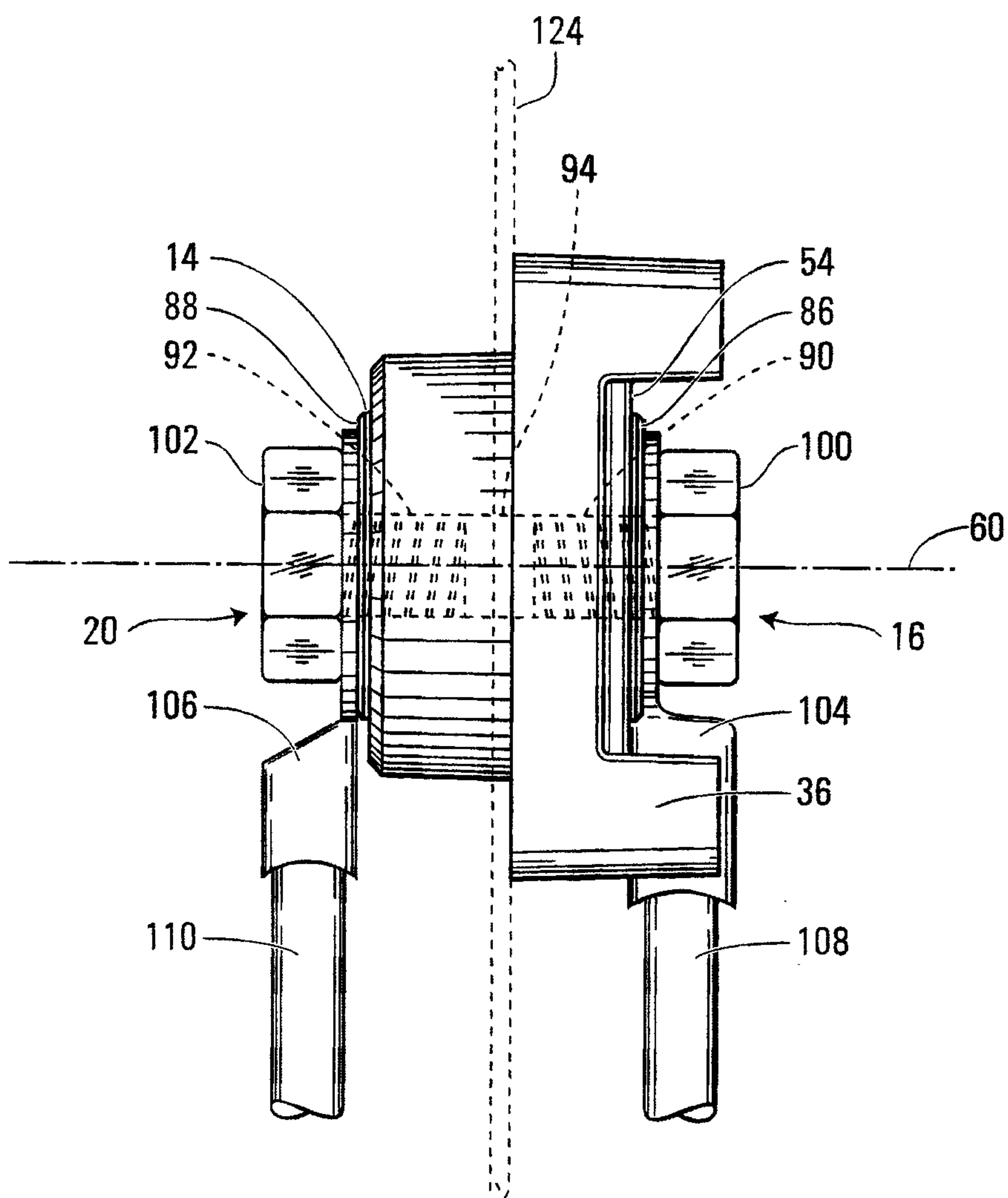

FIG. 6

5/8

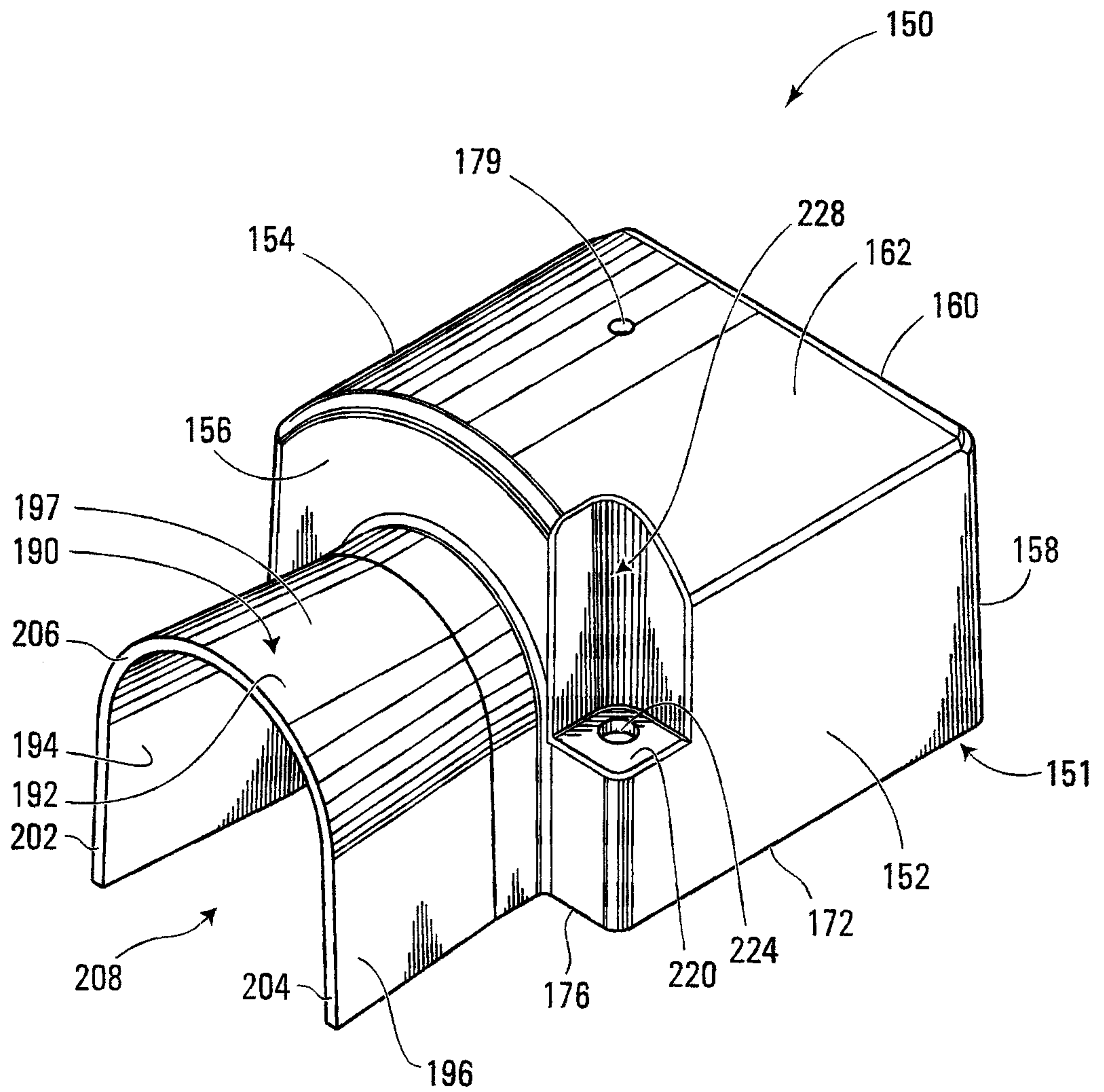

FIG. 7

+

6/8

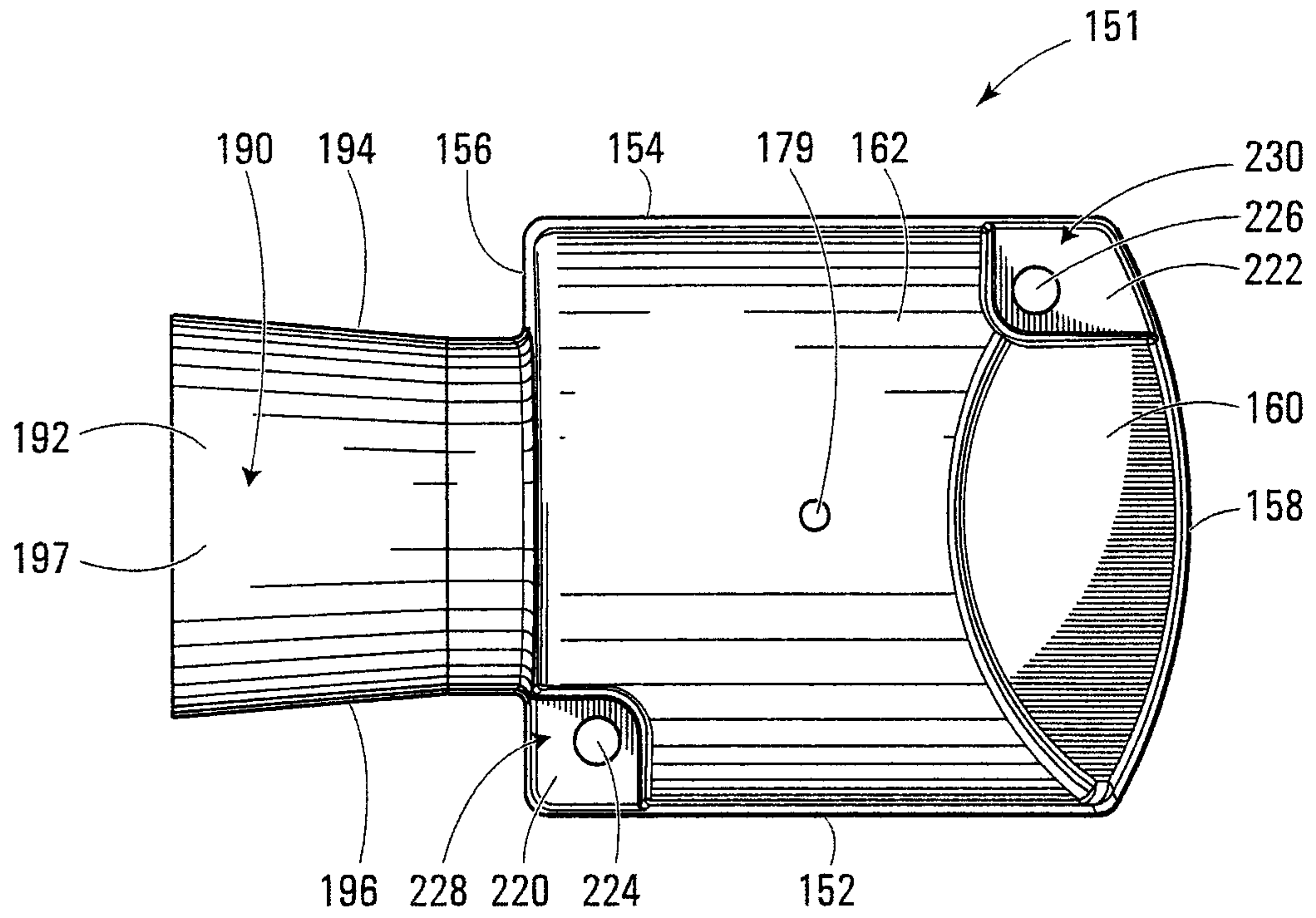

FIG. 8

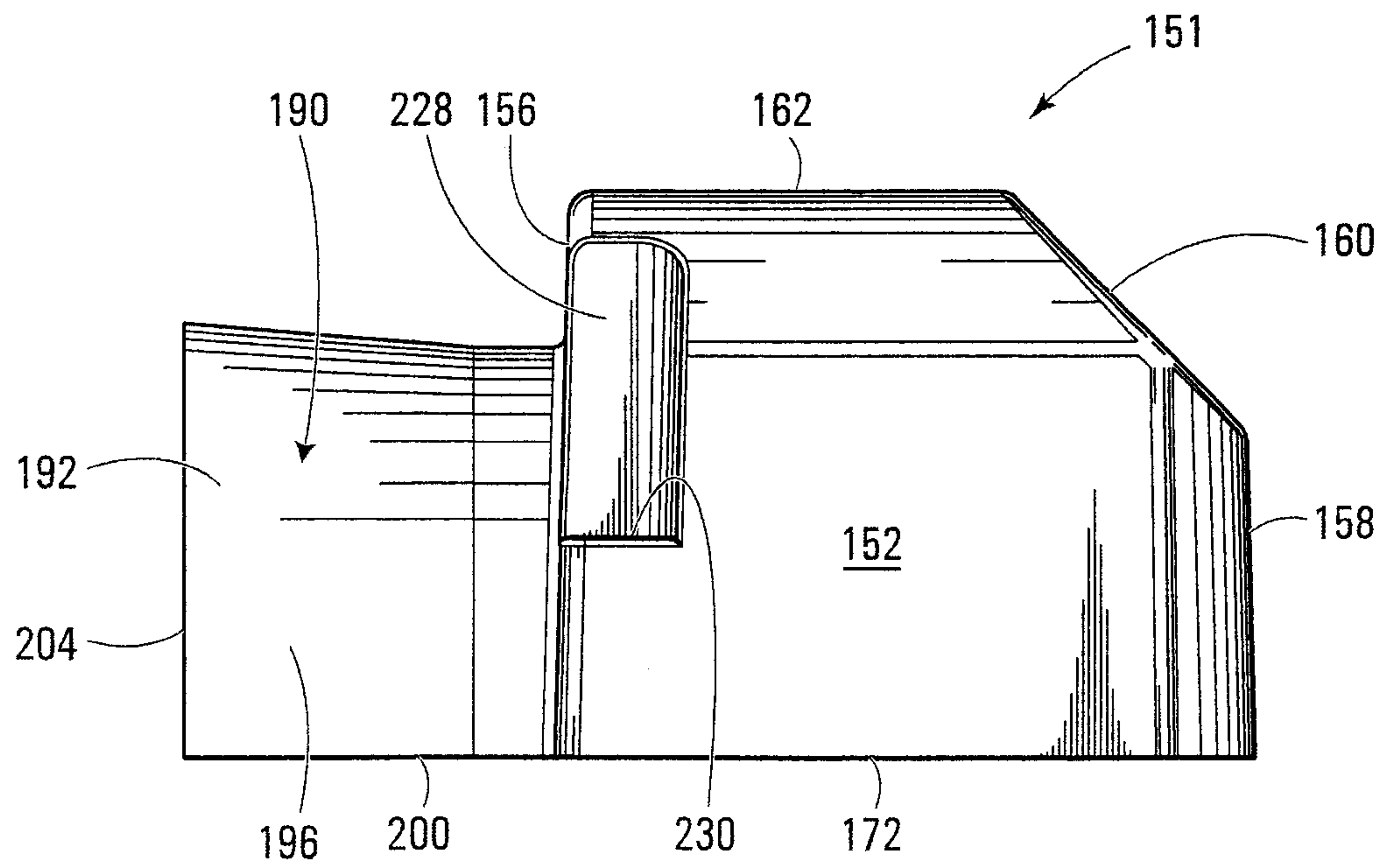

FIG. 9

+

+

7/8

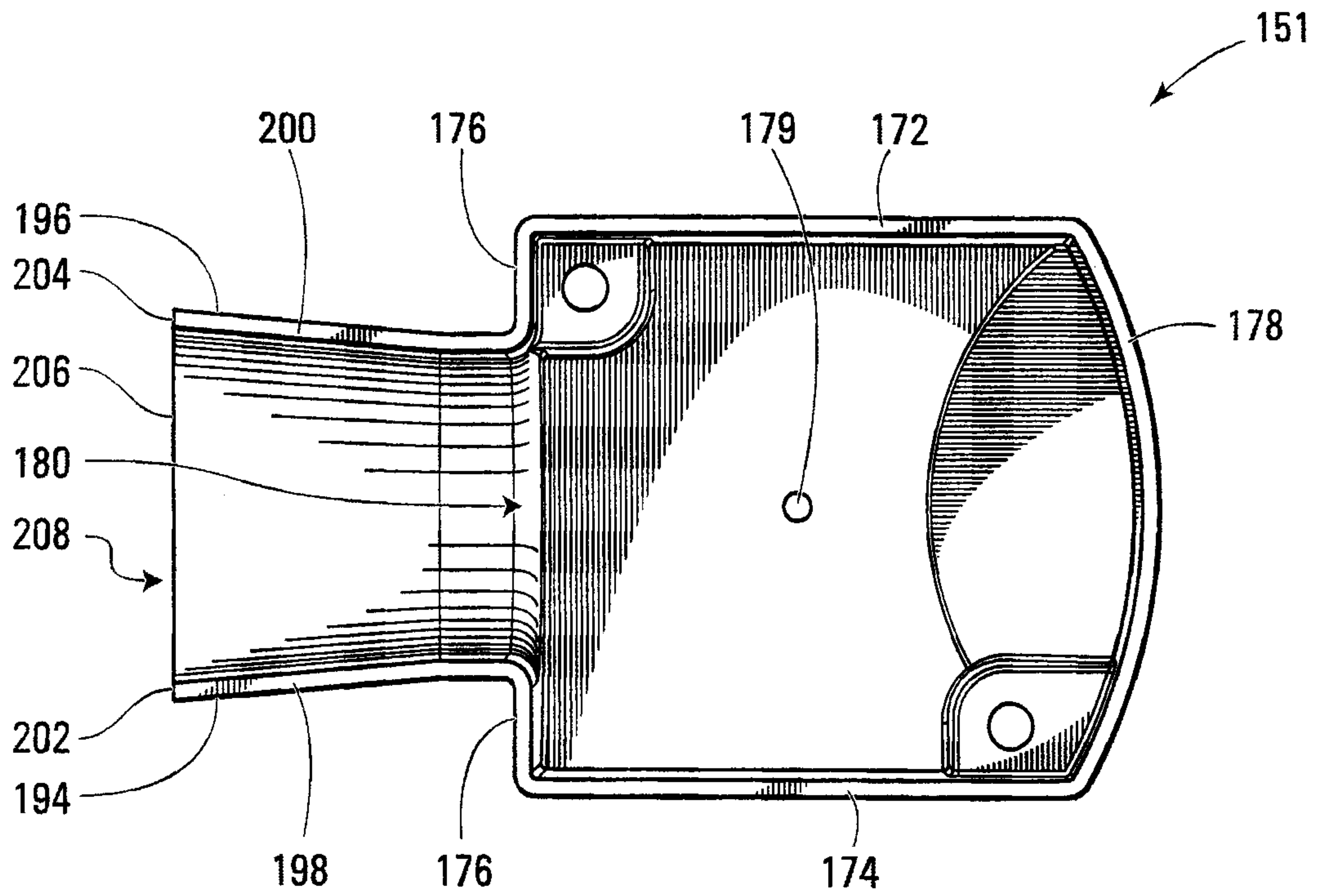

FIG. 10

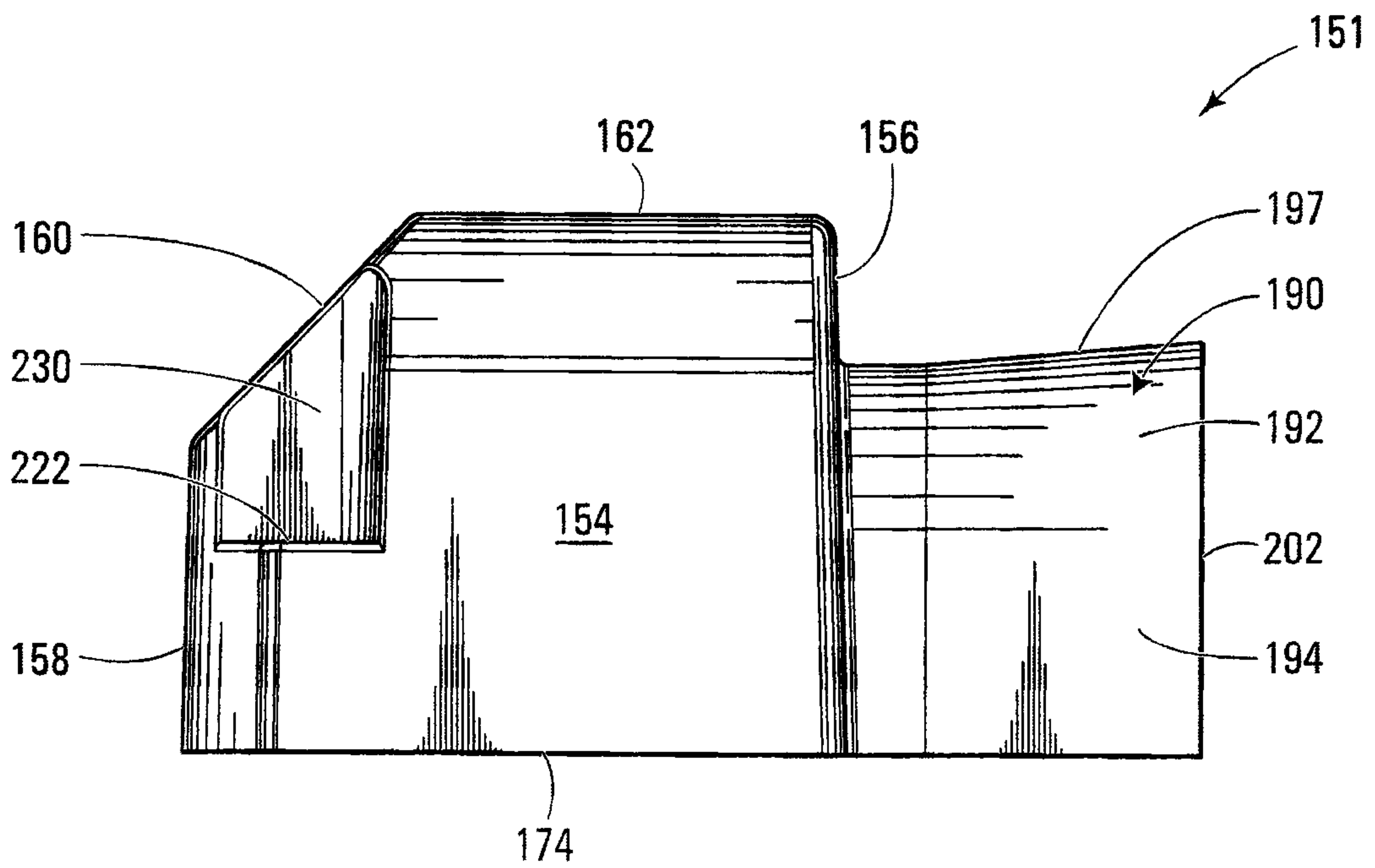

FIG. 11

+

8/8

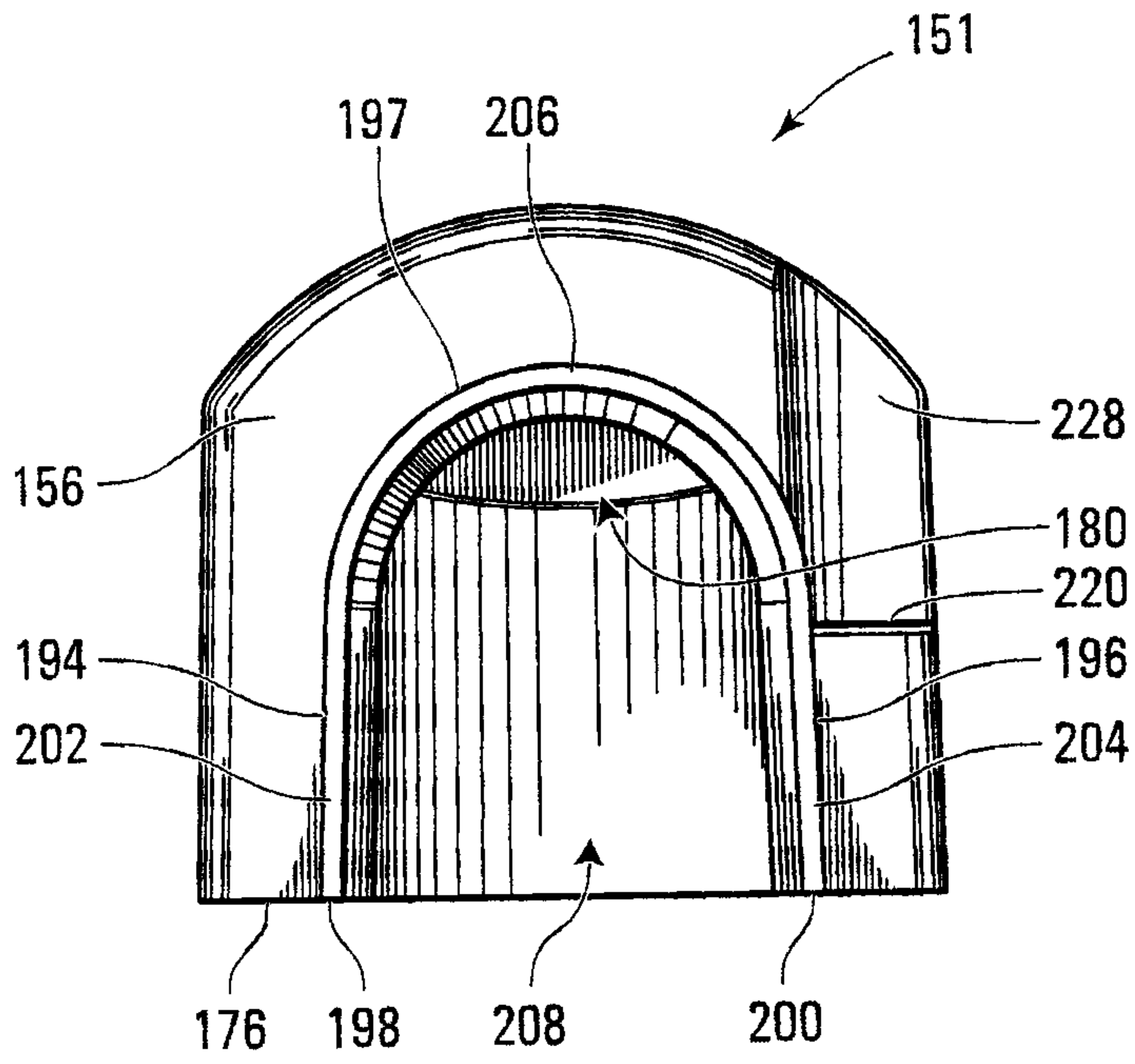

FIG. 12

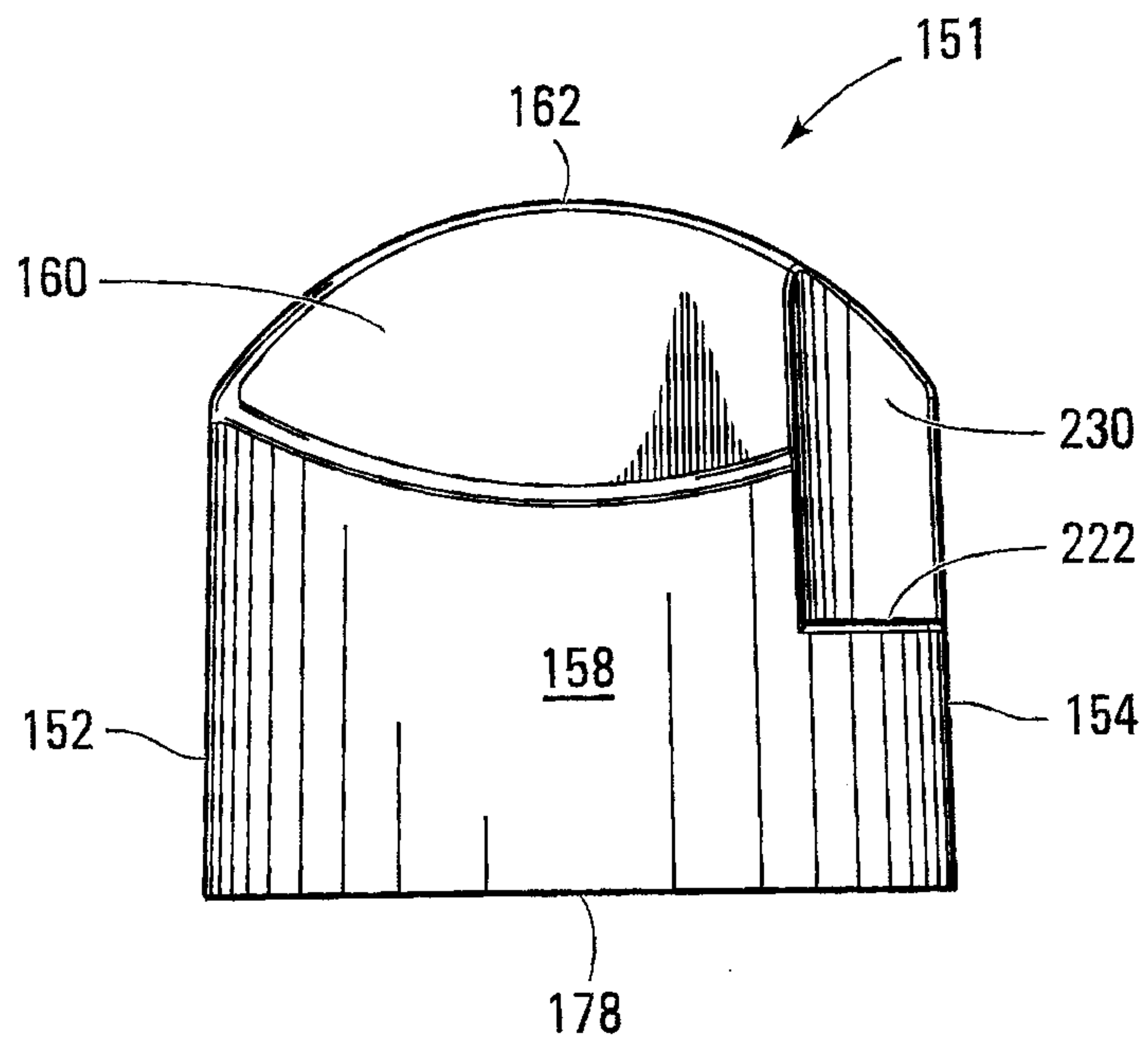

FIG. 13

