

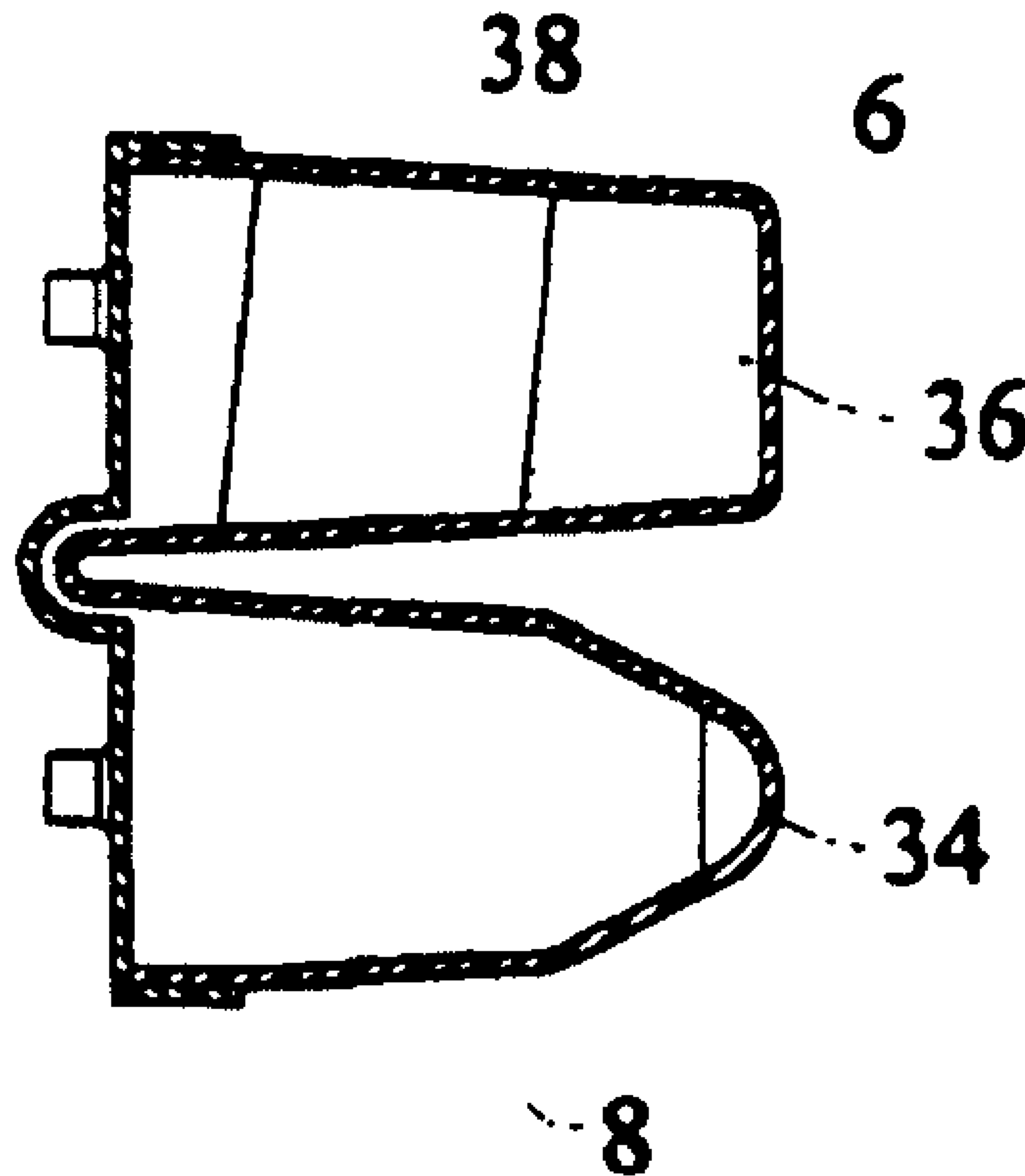

(86) Date de dépôt PCT/PCT Filing Date: 2000/04/11
 (87) Date publication PCT/PCT Publication Date: 2000/10/19
 (45) Date de délivrance/Issue Date: 2012/01/24
 (85) Entrée phase nationale/National Entry: 2000/12/12
 (86) N° demande PCT/PCT Application No.: US 2000/008718
 (87) N° publication PCT/PCT Publication No.: 2000/061256
 (30) Priorité/Priority: 1999/04/12 (US60/128,800)

(51) Cl.Int./Int.Cl. *A61K 35/16* (2006.01),
A61K 35/14 (2006.01), *B01D 21/26* (2006.01),
B04B 11/00 (2006.01), *B04B 15/00* (2006.01),
B04B 5/02 (2006.01)
 (72) Inventeurs/Inventors:
 BLASETTI, LOU, US;
 KEVY, SHERWIN V., US
 (73) Propriétaire/Owner:
 HARVEST TECHNOLOGIES CORPORATION, US
 (74) Agent: RIDOUT & MAYBEE LLP

(54) Titre : METHODE ET APPAREIL PERMETTANT DE PRODUIRE UN PLASMA RICHE EN PLAQUETTES ET/OU UN
 CONCENTRE DE PLAQUETTES
 (54) Title: METHOD AND APPARATUS FOR PRODUCING PLATELET RICH PLASMA AND/OR PLATELET
 CONCENTRATE



(57) Abrégé/Abstract:

Platelet rich plasma and/or platelet concentrate is prepared by placing whole blood in a first chamber (6) of a sterile processing disposable having two chambers (6, 8). The processing disposable is subjected to a first centrifugation to separate red blood cells

(57) **Abrégé(suite)/Abstract(continued):**

(36), and the resulting platelet rich plasma supernatant (38) is decanted to the second chamber (8). The processing disposable is subjected to a second centrifugation to concentrate platelets. A volume of the platelet poor plasma supernatant in the second chamber (8) is removed, and the platelets are re-suspended in the remaining plasma. The second chamber (8) may contain anticoagulant (34) to preclude aggregation of the platelets.

PCTWORLD INTELLECTUAL PROPERTY ORGANIZATION
International Bureau

INTERNATIONAL APPLICATION PUBLISHED UNDER THE PATENT COOPERATION TREATY (PCT)

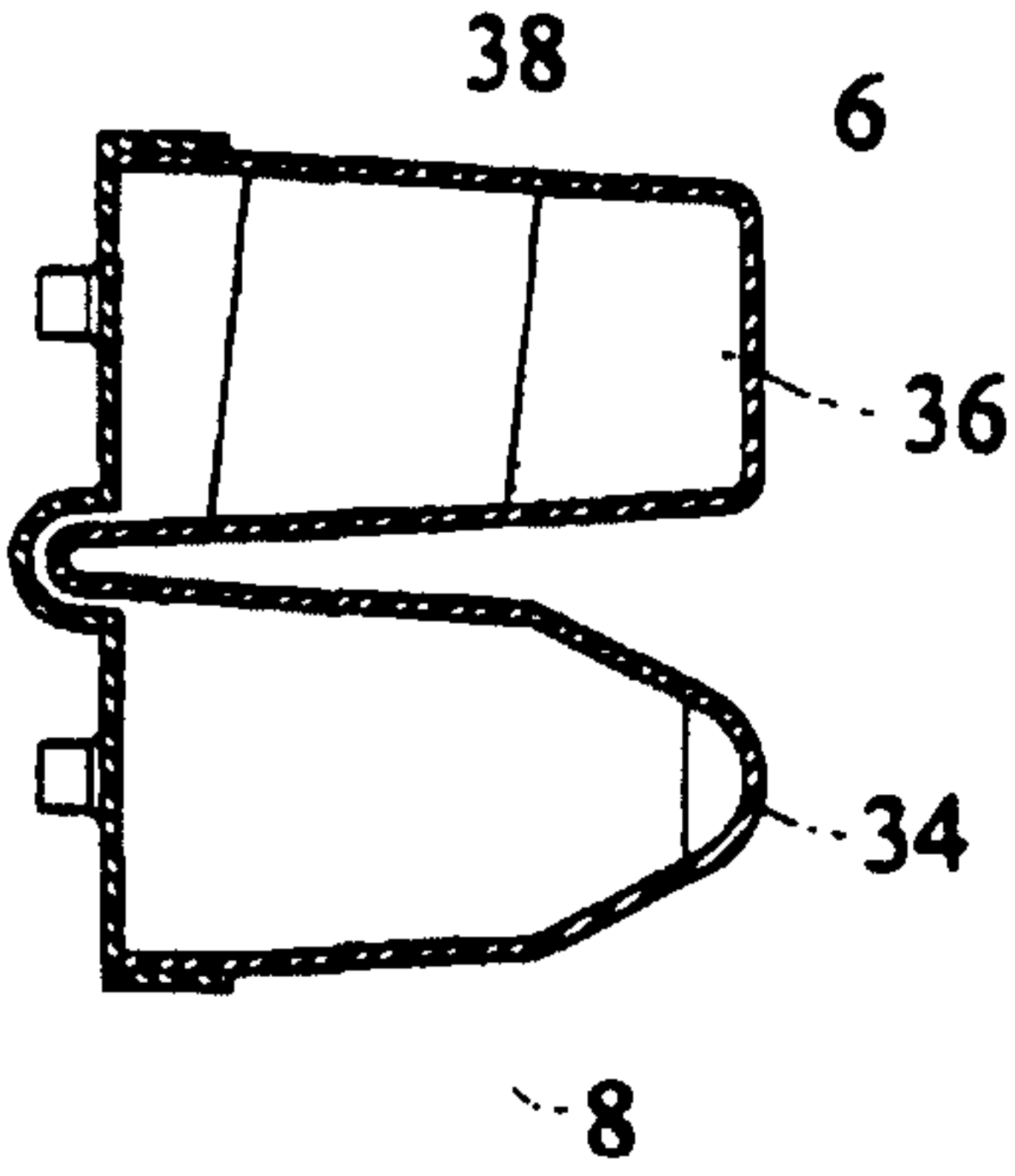
<p>(51) International Patent Classification ⁷ : B01D 21/26, B04B 5/02</p>	<p>A1</p>	<p>(11) International Publication Number: WO 00/61256</p> <p>(43) International Publication Date: 19 October 2000 (19.10.00)</p>
<p>(21) International Application Number: PCT/US00/08718</p> <p>(22) International Filing Date: 11 April 2000 (11.04.00)</p> <p>(30) Priority Data: 60/128,800 12 April 1999 (12.04.99) US</p> <p>(71) Applicant (for all designated States except US): HARVEST TECHNOLOGIES CORPORATION [US/US]; 77 Accord Park Drive D-7, Norwell, MA 02061 (US).</p> <p>(72) Inventors; and (75) Inventors/Applicants (for US only): BLASETTI, Lou [US/US]; 11 Ketch Lane, North Quincy, MA 02171 (US). KEVY, Sherwin, V. [US/US]; 6 Strathmore Road, Brookline, MA 02445 (US).</p> <p>(74) Agent: CLARK, Conrad, J.; Clark & Brody, Suite 600, 1750 K Street, NW, Washington, DC 20006 (US).</p>		<p>(81) Designated States: CA, CN, JP, US, European patent (AT, BE, CH, CY, DE, DK, ES, FI, FR, GB, GR, IE, IT, LU, MC, NL, PT, SE).</p> <p>Published <i>With international search report.</i></p>
<p>(54) Title: METHOD AND APPARATUS FOR PRODUCING PLATELET RICH PLASMA AND/OR PLATELET CONCENTRATE</p>		
<p>(57) Abstract</p>		
<p>Platelet rich plasma and/or platelet concentrate is prepared by placing whole blood in a first chamber (6) of a sterile processing disposable having two chambers (6, 8). The processing disposable is subjected to a first centrifugation to separate red blood cells (36), and the resulting platelet rich plasma supernatant (38) is decanted to the second chamber (8). The processing disposable is subjected to a second centrifugation to concentrate platelets. A volume of the platelet poor plasma supernatant in the second chamber (8) is removed, and the platelets are re-suspended in the remaining plasma. The second chamber (8) may contain anticoagulant (34) to preclude aggregation of the platelets.</p>	 <p>The diagram shows a cross-section of a sterile processing disposable, which is a U-shaped container with two chambers, 6 and 8, separated by a central divider. Chamber 6 is the upper chamber and chamber 8 is the lower chamber. A curved channel, 36, connects the two chambers. A small reservoir, 34, is located at the bottom of chamber 8. A label 38 points to the upper portion of chamber 6. The entire device is labeled 8 at the bottom.</p>	

combination also provides more secure placement of organic materials, for example, into an orthopedic defect. Some properties of

PRP/PC and thrombin (e.g., hemostasis and wound sealing) are similar to those of fibrin glue, except that fibrin glue has a greater adhesive property because of its concentration of fibrinogen above baseline levels.

A typical method of producing PC involves subjecting whole blood collected in a blood bag system to centrifugation to separate PRP from red blood cells. Then, the PRP is expressed from the first bag to a second bag and again subjected to centrifugation, which results in a concentration ("pellet") of platelets (PC) and a supernatant of platelet poor plasma (PPP). The majority of the PPP is expressed to a third bag, leaving the concentrated platelets and a small proportion of PPP behind in the second bag, which is used for re-suspending the concentrated platelets. This method, with a typical platelet recovery efficiency of only 45%, is too cumbersome for point-of-care use and, as a result, does not lend itself to point-of-care production of autologous blood products.

One automated system for the production of autologous fibrinogen from plasma is known from US Patent 5,707,331 (Wells). That patent teaches a system for automated processing of whole blood by centrifugation into a plasma component that is further processed by physiochemical precipitation and further centrifugation into a fibrinogen component. The fibrinogen is recovered and provides a fibrin sealant when combined with thrombin.

The ability to produce PRP/PC on demand from small amounts of whole blood would greatly facilitate clinical utility of PRP/PC, and availability of autologous PRP/PC would eliminate the need for homologous PRP/PC, which may carry the risk of transmitting human disease. Further, it is often desirable to provide PRP/PC of a selected concentration to achieve a

particular therapeutic outcome. However, the known methods presently used for producing PRP/PC are time consuming, inefficient, and do not lend themselves to production from small amounts of whole blood.

Accordingly, it is an object of this invention to provide a method and
5 apparatus for processing efficiently small volumes of whole blood into PRP or PC of any selected concentration on demand, at the point of care, and in the clinical setting.

SUMMARY OF THE INVENTION

In accordance with the invention, small amounts of PRP or PC are
10 easily produced by an automated method preferably carried out by a centrifuge such as that shown in US Patent 5,707,331 (Wells). The centrifuge shown in the '331 Wells patent receives a disposable container, or processing disposable (PD), having two chambers, and in the method of the present invention, whole blood is first placed in one chamber of the PD. The
15 centrifuge is then operated to cause the red blood cells to sediment to the bottom of one chamber resulting in a supernatant of PRP. The centrifugation is stopped/reduced causing the PRP to drain to the second chamber, either by gravity or by centrifugal transfer.

PRP in the second chamber is then centrifuged a second time by
20 restarting/accelerating the centrifuge. The centrifuge is then stopped, resulting in: (1) red blood cells in the one chamber, (2) platelets (PC) at the bottom of the second chamber, and (3) platelet poor plasma (PPP) as the supernatant in the second chamber. The foregoing operation of the centrifuge is preferably automated.

The operator may then produce PRP/PC of a desired concentration by obtaining a prescribed volume of the plasma supernatant and re-suspending the platelets.

In a preferred embodiment, the operator inserts a blunt cannula attached to a syringe into the second chamber and withdraws a desired volume of plasma, which leaves behind a known volume of plasma. A second blunt cannula attached to a syringe is then inserted into the second chamber where the remaining known volume of plasma is used to re-suspend and recover the PRP/PC having increased platelet concentration.

There may be other ways to recover the platelets and plasma. For example, after completion of the automated steps, the operator could decant plasma from the second chamber by tilting the disposable container to cause an amount of plasma to return to the first chamber, leaving the desired amount of plasma in the second chamber. The remaining plasma and the platelets would then be mixed and recovered.

In one example, a patient's whole blood sample is obtained, containing a typical platelet count of $220 \times 10^3/\mu\text{l}$. Based on a typical platelet recovery efficiency of 60% and processing a typical blood volume of 50ml, re-suspending the PC in 5ml of PPP will provide PRP with a platelet concentration of $1,320 \times 10^3/\mu\text{l}$, a six-fold increase in the platelet concentration.

Thus, according to the present invention, there is provided a method for producing a physiological fluid of selected composition comprising the steps of: placing a physiological fluid having a plurality of components in a first chamber of a sterile container of a defined volume having horizontally spaced first and second chambers; subjecting said physiological fluid to centrifugation to

separate at least one of said components from a more dense first supernatant; decanting said first supernatant to said second chamber; subjecting said first supernatant to centrifugation to separate a second of said components from a second supernatant; removing a predetermined amount of said second
5 supernatant from said second chamber whereby a remainder of said second supernatant is in said second chamber; and re-suspending said second of said components in said remainder of said second supernatant in said second chamber.

According to another aspect of the present invention, there is provided a
10 method for making platelet rich plasma of increased concentration at point of care comprising the steps of placing blood in a first chamber of a sterile container having first and second chambers, wherein at least said second chamber is of a defined volume, subjecting said container and blood to centrifugation to provide a supernatant comprising platelet rich plasma,
15 transferring said platelet rich plasma from said first chamber to said second chamber, subjecting said platelet rich plasma to centrifugation to provide separated platelets and platelet poor plasma, removing a portion of said platelet poor plasma from said second chamber and leaving a remaining portion of said platelet poor plasma and said separated platelets in said second chamber, and
20 suspending said separated platelets in said remaining portion of said platelet poor plasma to obtain said platelet rich plasma of increased concentration.

BRIEF DESCRIPTION OF THE DRAWINGS

Figure 1 illustrates a disposable processing tube and centrifuge in accordance with the invention.

Figure 2 is a side view of the processing tube shown in figure 1, partly in vertical cross section.

Figures 3a through 3f are schematic cross sections of the processing tube of figure 2 showing the various orientations of the processing tube during operation of the centrifuge in accordance with the invention.

DETAILED DESCRIPTION OF THE PREFERRED EMBODIMENT

Figure 1 schematically illustrates a centrifuge system 2 and a processing disposable (PD) 4 in accordance with the invention. The preferred centrifuge is that described in United States Patent 5,707,331 (Wells) programmed to operate as will be described in connection with figure 3. As will be appreciated, the rotor of the centrifuge 2 is designed to accept one or more PDs 4 simultaneously. In the preferred embodiment, the centrifuge accepts one or two PDs. A counterweight is placed opposite a filled PD when only one is used.

The PD used in accordance with the invention and shown in figure 2 is that shown in the noted '331 patent. This PD is preferably made of molded plastic and includes at least two chambers 6, 8. The two chambers are connected by a bridge 10, which connects the two chambers, preferably, at their tops. The chambers are closed by a lid 12, which maintains sterility of the fluid paths.

The lid includes extensions 18 and 20 having respective openings 22 and 24 for permitting access to the interior of the chambers. Chamber 6 includes a shelf 26 for assisting in the separation of PRP from cellular components, as will be described in more detail below. Chamber 6 also includes a hollow tube 28, which extends from the opening 22 through the

shelf 26 to facilitate insertion of fluids into the chamber 6. The perimeter of the shelf allows plasma below the shelf 26 to flow upward.

Referring now to figures 3a through 3f, the operation of the centrifuge 2 in accordance with the process of the invention will be described. In the first step of the process, chamber 6 of the PD 4 is provided with a measured quantity of a physiological fluid 32 to be processed, such as whole human blood. A quantity (e.g., 1-5ml and preferably 2ml) of anticoagulant 34, preferably ACD-A, is added to chamber 8. Then, the PD is subjected to centrifugation as illustrated in figure 3b. This separates heavier components of the physiological fluids, such as red blood cells 36, from the supernatant, such as PRP 38. The ACD-A 34 remains in chamber 8.

The first centrifugation illustrated in figure 3b causes the red blood cells to separate from the PRP but does not significantly separate platelets from the remainder of the plasma. In the preferred embodiment, this first centrifugation is done at about 1200G (approximately 3600RPM) for a period of about two minutes.

For clarity figures 3a through 3f do not illustrate the shelf 26, but it should be noted that in the preferred embodiment, the shelf is located as close as possible to the boundary between the separated components, namely the red blood cells 36 and the plasma 38. The preferred method for accomplishing this is to determine the concentration of red blood cells in the patient's blood (i.e., the hematocrit) and to provide a quantity of blood that will fill the volume below the shelf with the red blood cells. Preferably, the chamber 6 is designed to accept 50ml of patient's blood as the nominal volume. This amount is adjusted during operation of the equipment in

accordance with the hematocrit, and applicants have found that the volume of whole blood required will be in the range of 40ml-60ml.

After the red blood cells have been centrifugally separated, the PD is locked in the gravity drain position shown in figure 3c. This is described further in the '311 Wells patent and is preferably done by electrical activation of a magnet that moves a locking plate into engagement with a holder having the PD therein. When the PD is in this position, the PRP 38 in chamber 6 drains into the chamber 8 by gravity. For example, 25 ml of PRP is transferred to chamber 8. The PRP 38 also mixes with the ACD-A 34, previously in chamber 8, as it flows into the chamber through the flow channel 16.

It is often desirable during the draining step shown in figure 3c to continue rotation of the rotor at a slow speed, e.g., 60RPM, to provide a slight centrifugal force to ensure retention of the red blood cells 36 in the chamber 6.

As illustrated in figure 3d, the centrifuge is then accelerated again to subject the PRP 38 to centrifugation. The second centrifugation separates platelets 40 from the PPP supernatant 42. In the preferred embodiment, the second centrifugation is at about 1000G (approximately 3000RPM) for a period of about eight minutes.

It will be appreciated that the specific rotation rates for the first and second centrifugation steps can be varied. For example, the second centrifugation can be a hard spin. Also, the disclosed preferred rates are for a centrifuge having a maximum rotor radius of four inches (i.e., the radius of

rotation measured from the axis to the bottom of the chamber). Centrifuges with other dimensions will require different rotation rates.

The ACD-A is provided in the chamber 8 for minimizing platelet aggregation. It has been found that the presence of an anticoagulant in the second chamber reduces aggregation of the platelets, thus shortening the overall time required for processing.

The next step in the process of the invention is shown in figure 3e. In this step, the centrifugation has been stopped, and the PD is allowed to assume an upright orientation, with the red blood cells 36 remaining in chamber 6, the platelets 40 at the bottom of chamber 8, and the PPP 42 as the supernatant in chamber 8. A hypodermic syringe 44 with a blunt cannula 46 is used for removing a predetermined amount of PPP. This is accomplished by inserting the blunt cannula through the opening 24 to a predetermined depth. The operator may determine that depth manually, or, as shown in figure 3e, a height adjusting guide 48 may be provided over the cannula to stop insertion at the desired depth. The guide may take any of several forms, the preferred form being a hollow tube that fits over the cannula and engages the bottom of the syringe. Also, a kit having a plurality of such guides of different lengths may be provided for allowing the operator to select one for withdrawal of different, predetermined amounts of PPP.

It will be appreciated that the described use of cannula 46 with height adjusting guide 48 removes from the chamber 8 a predetermined amount of fluid that in this case is equal to the difference between the volume of fluid in the chamber initially and the desired volume of fluid as defined by the height of the guide 48.

Further, removal of a desired amount of PPP may be accomplished by decanting some of the plasma back to chamber 6, either manually or by centrifugal transfer using the multiple-decanting features of the centrifuge described in the '331 Wells patent.

Continuing with the process shown in figure 3e, the syringe is operated after insertion of the cannula 46 to the desired depth to withdraw the desired amount of PPP, which is then used for other purposes, such as hemostasis.

As shown in figure 3f, the platelets 40 are then re-suspended in the
5 remaining PPP to result in PRP/PC 50 with a desired platelet concentration that is several times higher than was the original supernatant 38. This PRP/PC of increased concentration is then used for any of a variety of purposes as are known in the art.

Modifications within the scope of the appended claims will be apparent
10 to those of skill in the art.

We Claim:

1. A method for producing a physiological fluid of selected composition comprising the steps of:

5 placing a physiological fluid having a plurality of components in a first chamber of a sterile container of a defined volume having horizontally spaced first and second chambers;

subjecting said physiological fluid to centrifugation to separate at least one of said components from a more dense first supernatant;

10 decanting said first supernatant to said second chamber;

subjecting said first supernatant to centrifugation to separate a second of said components from a second supernatant;

15 removing a predetermined amount of said second supernatant from said second chamber whereby a remainder of said second supernatant is in said second chamber; and

re-suspending said second of said components in said remainder of said second supernatant in said second chamber.

2. A method according to claim 1 further comprising the step of placing
20 anticoagulant in said second chamber.

3. A method according to claim 1 wherein said physiological fluid is blood.

4. A method according to claim 3 wherein said physiological fluid is platelet rich plasma and said step of subjecting said physiological fluid to centrifugation comprises subjecting blood to a first centrifugation for about two minutes.
- 5 5. A method according to claim 4 wherein said step of subjecting said first supernatant to centrifugation comprises subjecting platelet rich plasma to a second centrifugation for about eight minutes.
6. A method for making platelet rich plasma of increased concentration at
10 point of care comprising the steps of placing blood in a first chamber of a sterile container having first and second chambers, wherein at least said second chamber is of a defined volume, subjecting said container and blood to centrifugation to provide a supernatant comprising platelet rich plasma, transferring said platelet rich plasma from said first chamber to said second
15 chamber, subjecting said platelet rich plasma to centrifugation to provide separated platelets and platelet poor plasma, removing a portion of said platelet poor plasma from said second chamber and leaving a remaining portion of said platelet poor plasma and said separated platelets in said second chamber, and suspending said separated platelets in said remaining portion of said platelet
20 poor plasma to obtain said platelet rich plasma of increased concentration.
7. A method according to claim 6 further comprising the step of placing an anticoagulant in said second chamber.

8. A method according to claim 6 wherein said step of removing comprises inserting a cannula into said second chamber and withdrawing said portion of platelet poor plasma.

FIG. 1

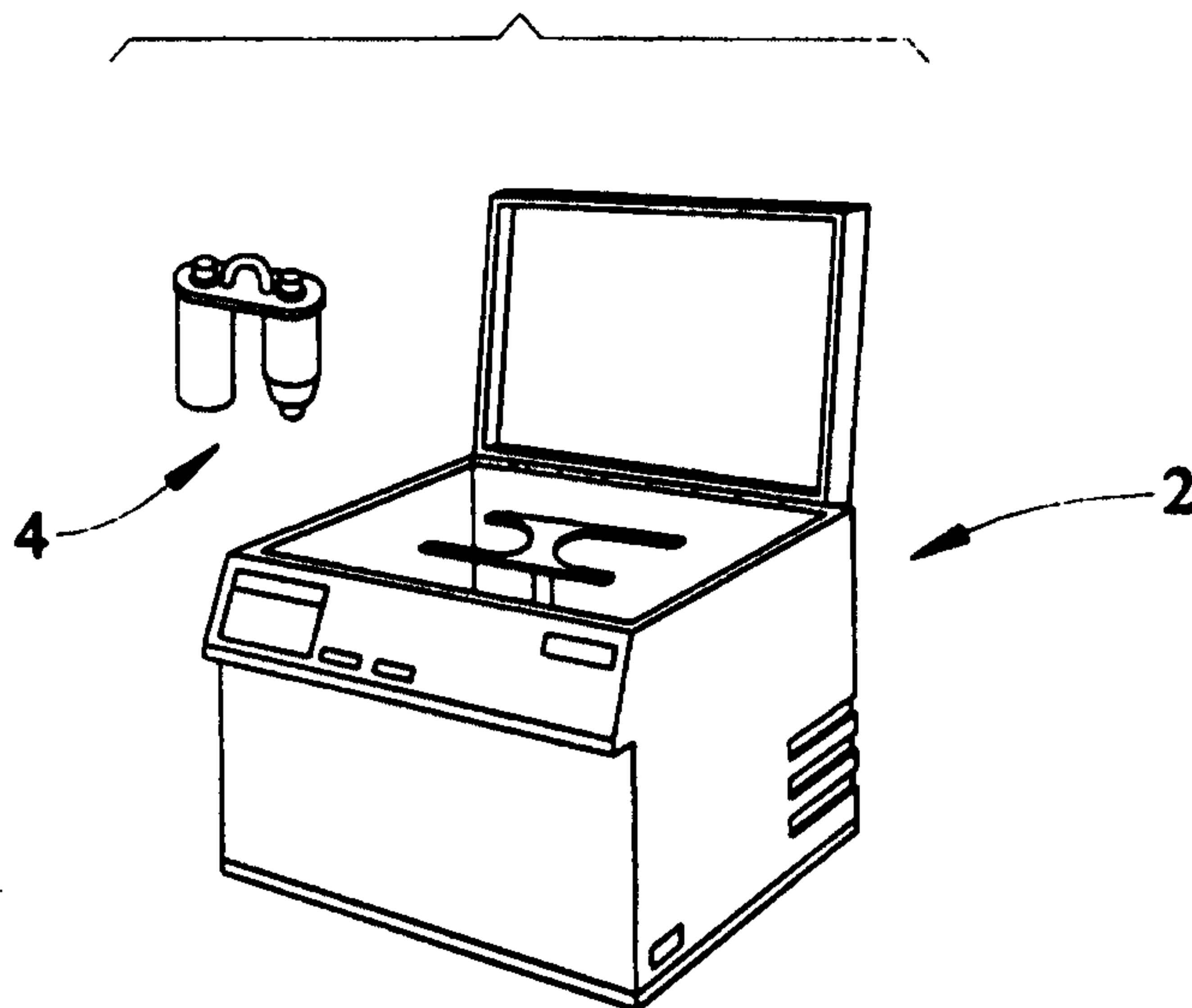

FIG. 2

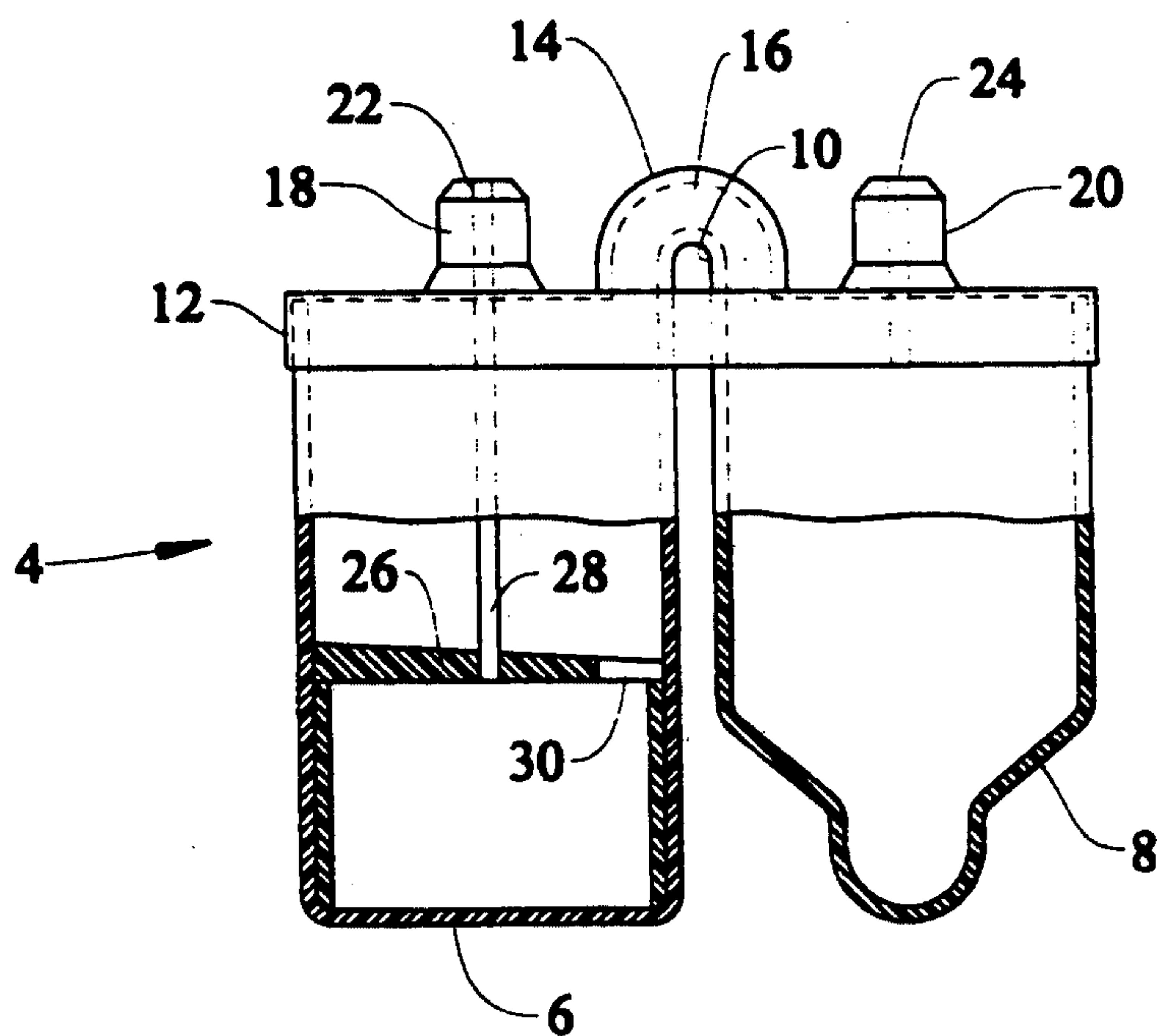

FIG. 3a

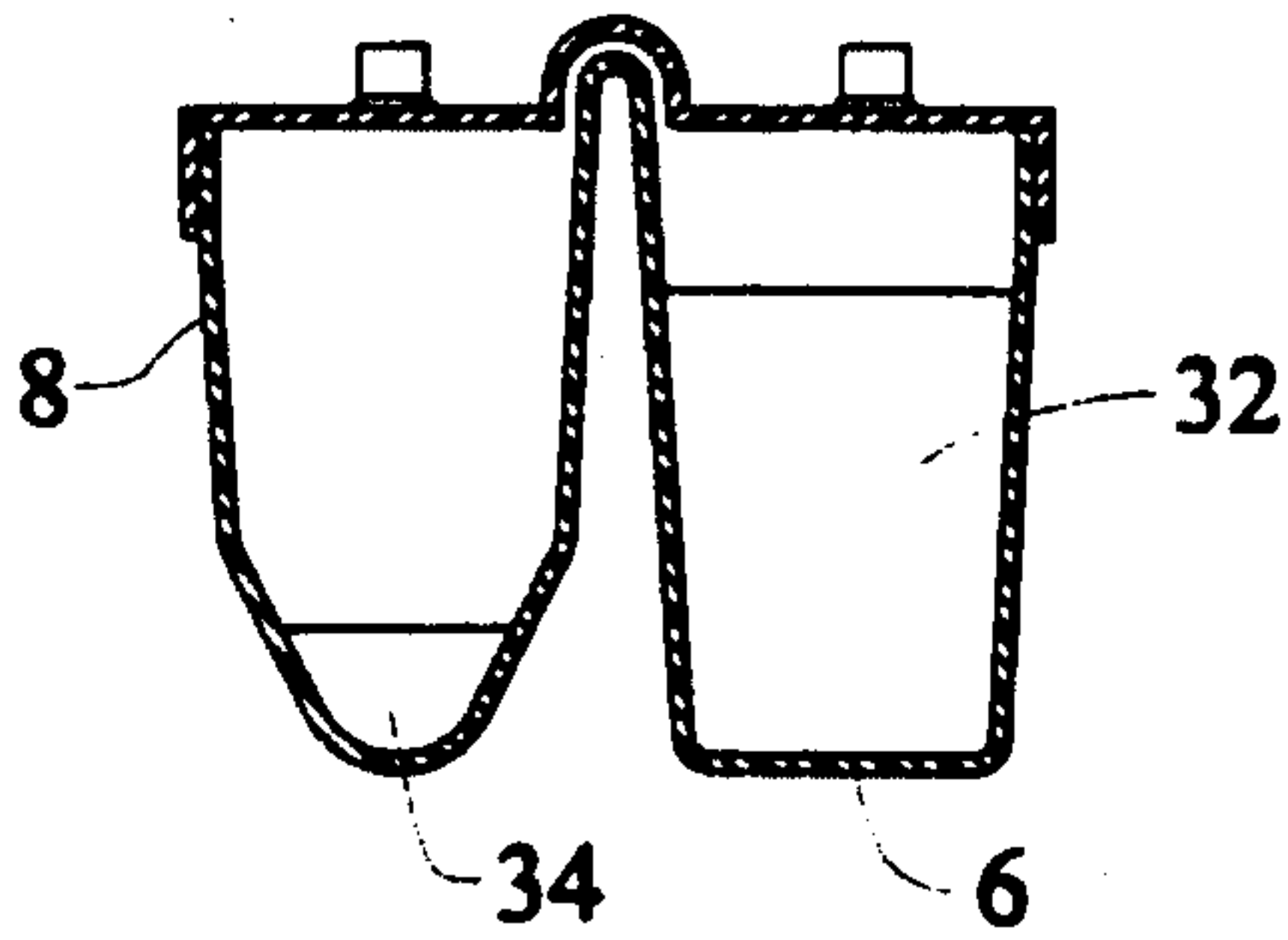

FIG. 3b

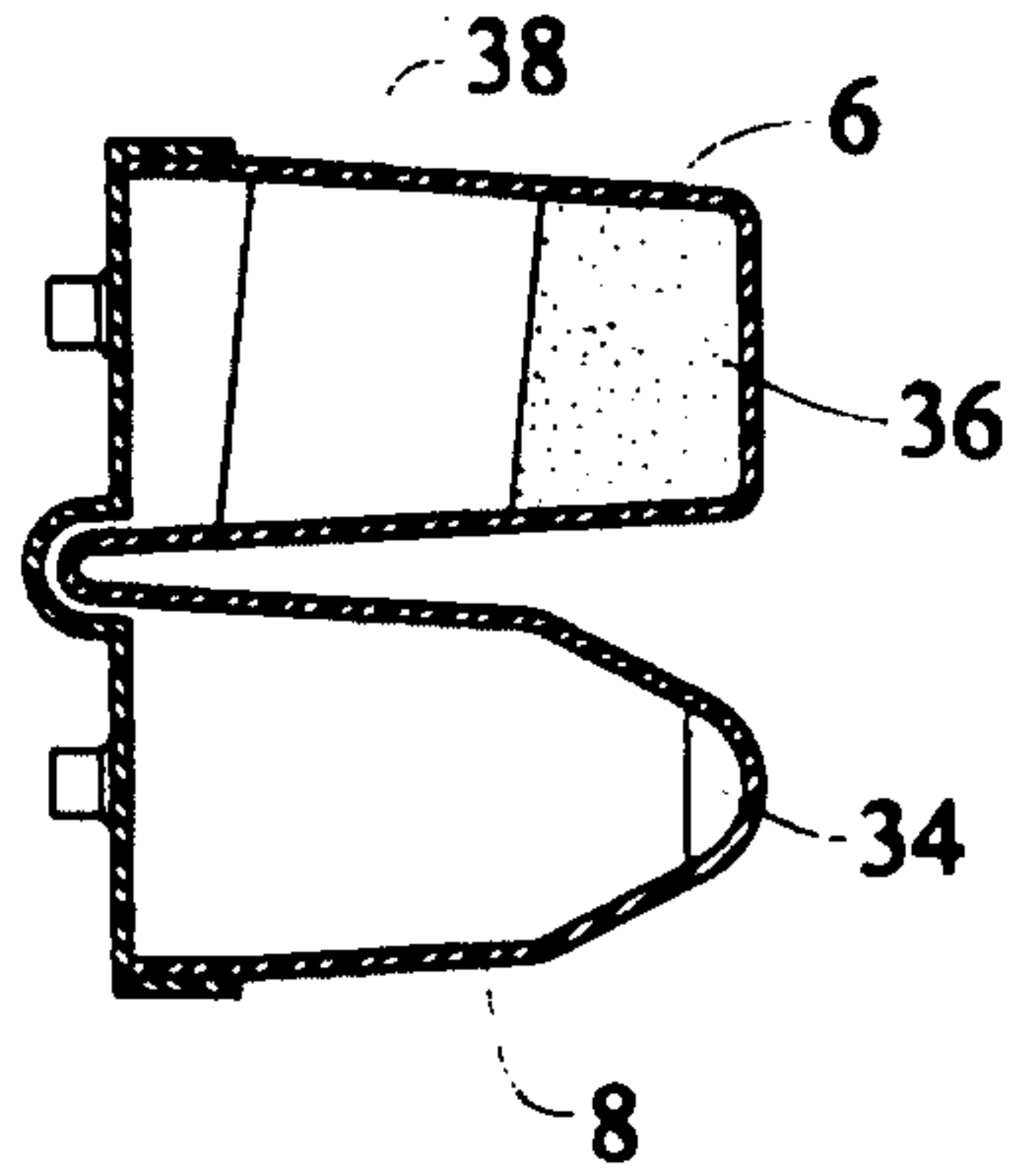

FIG. 3c

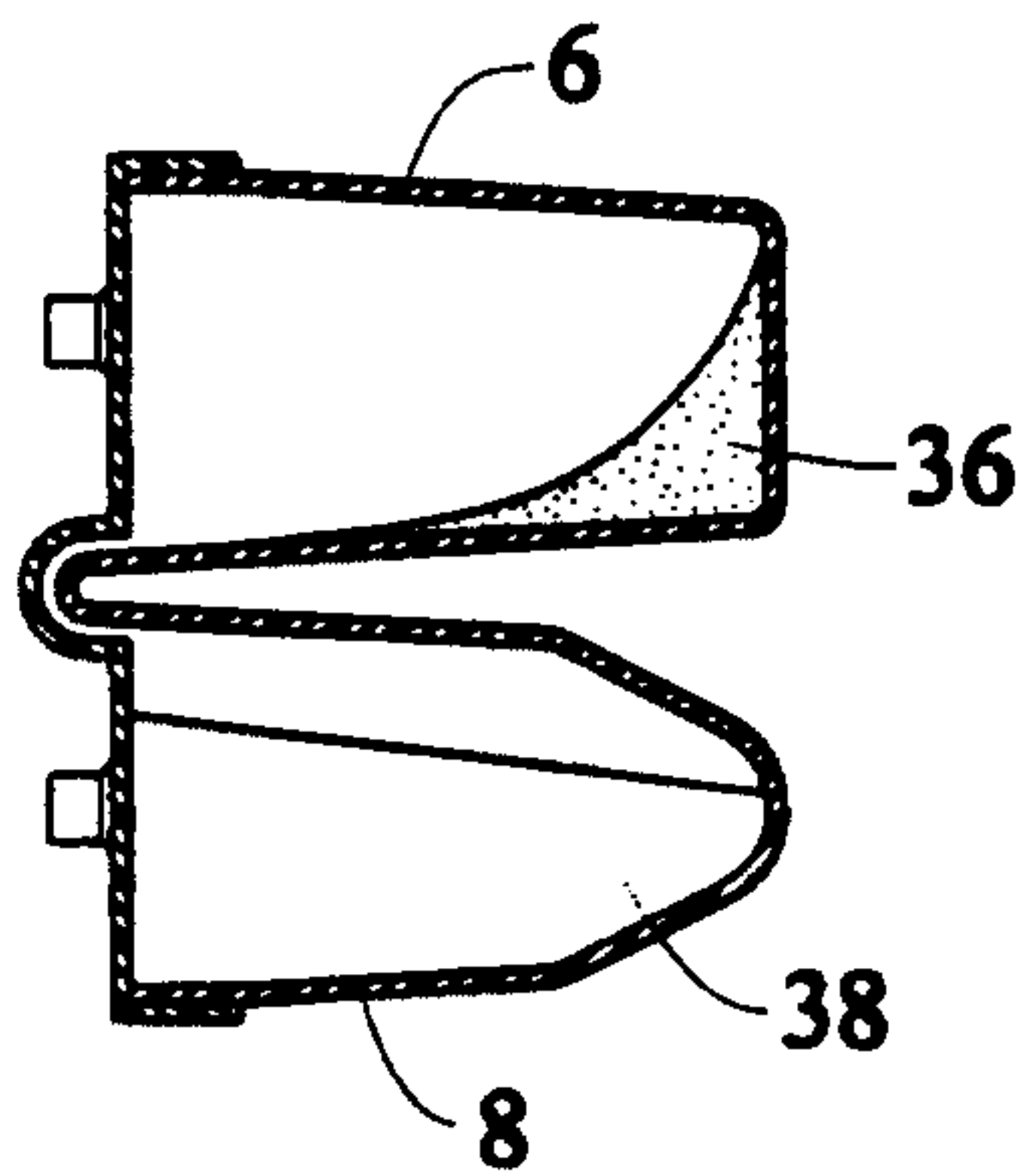

FIG. 3d

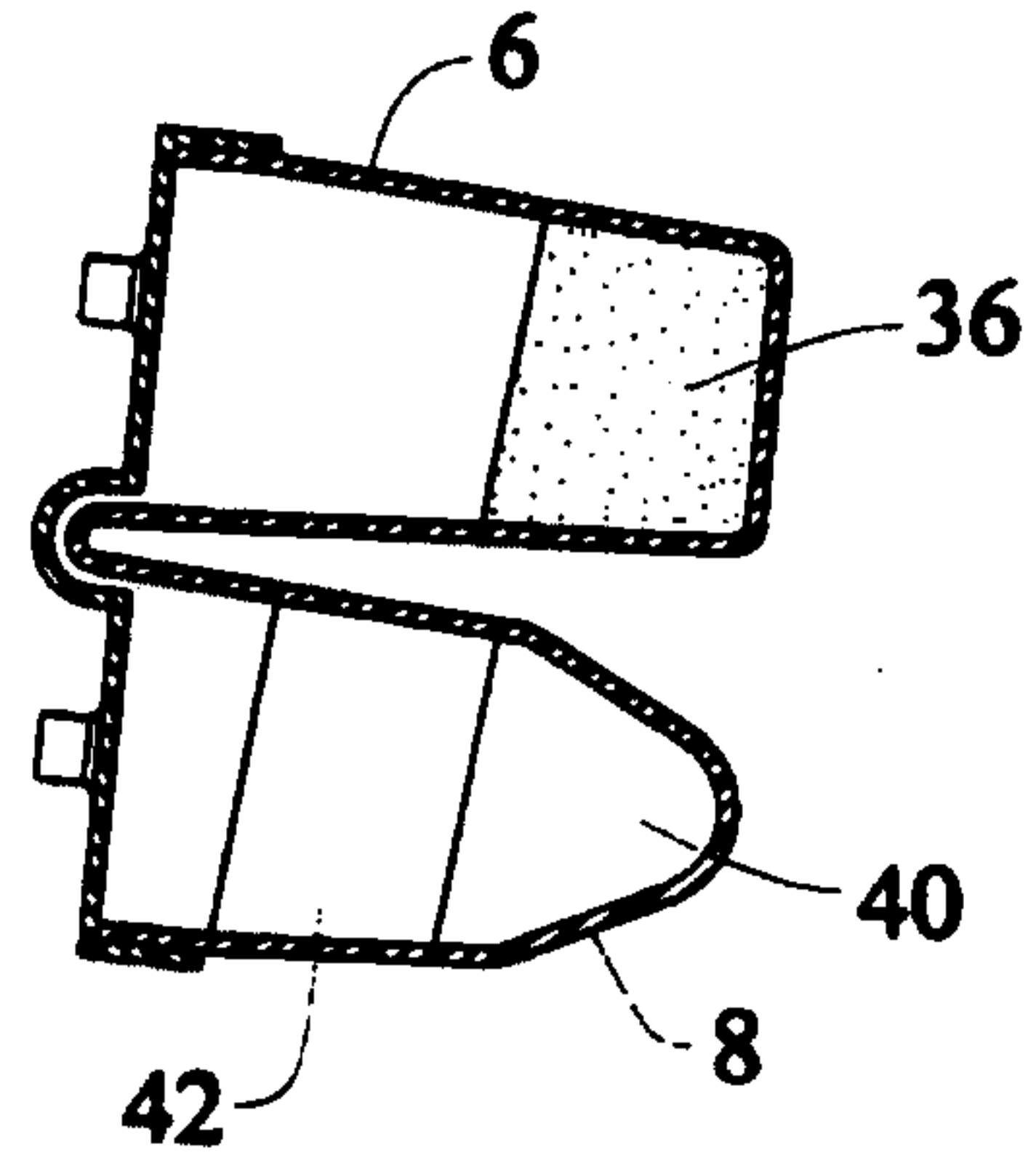

FIG. 3e

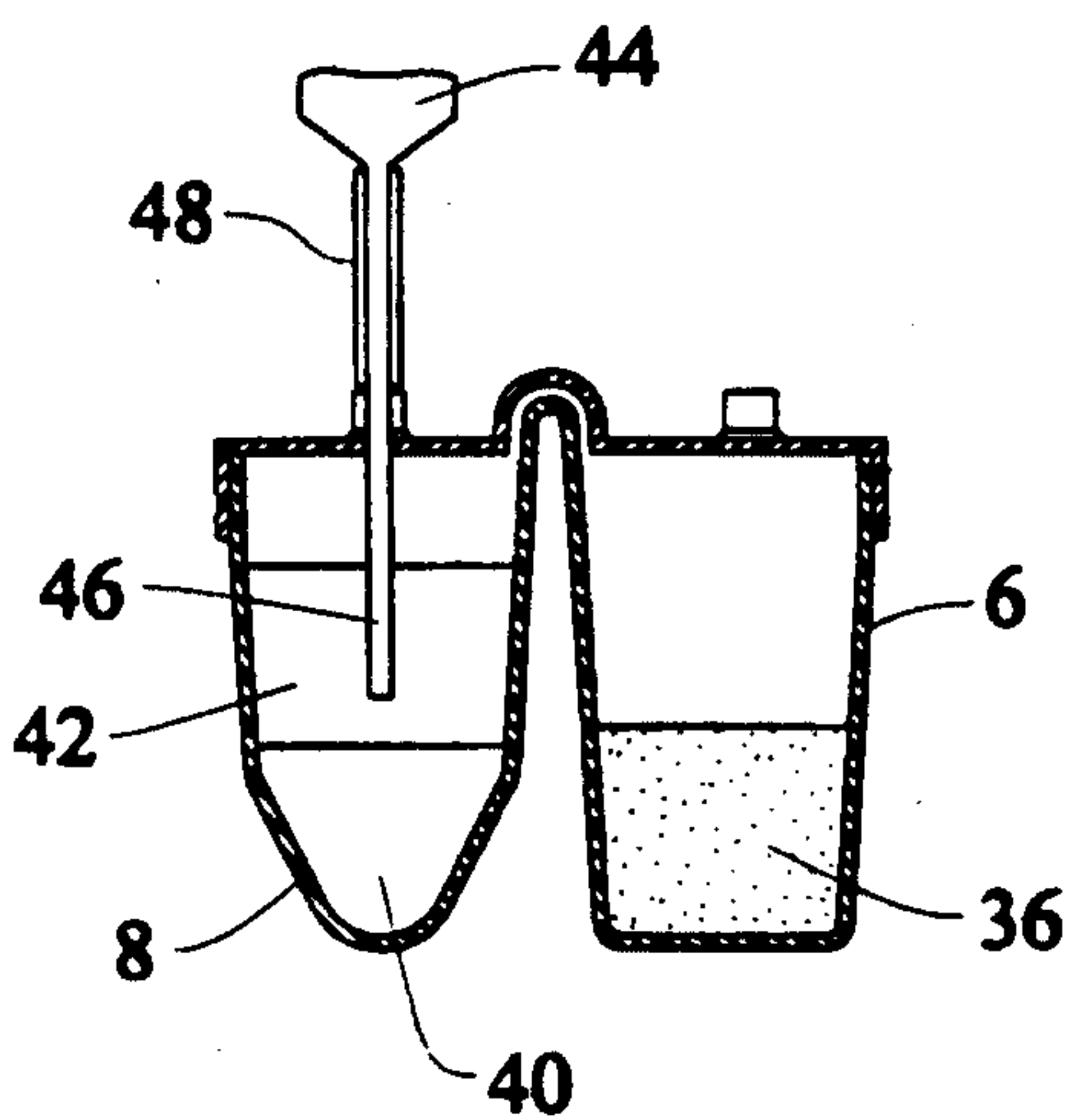
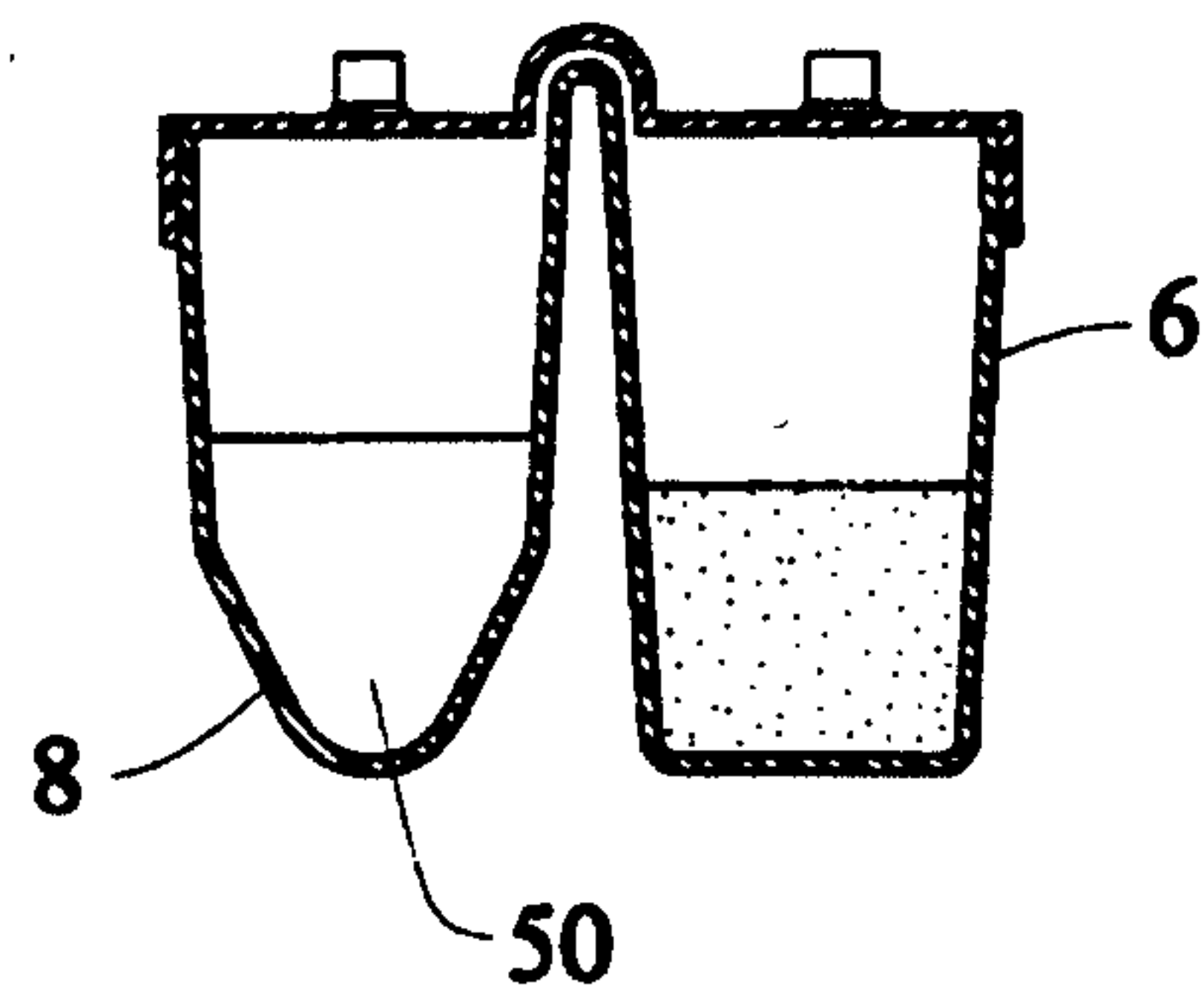

FIG. 3f



38

6

36

34

8

