

R. J. EDWARDS.

Grinding and Polishing Wheels.

No. 134,134.

Patented Dec. 24, 1872.

Fig. 1

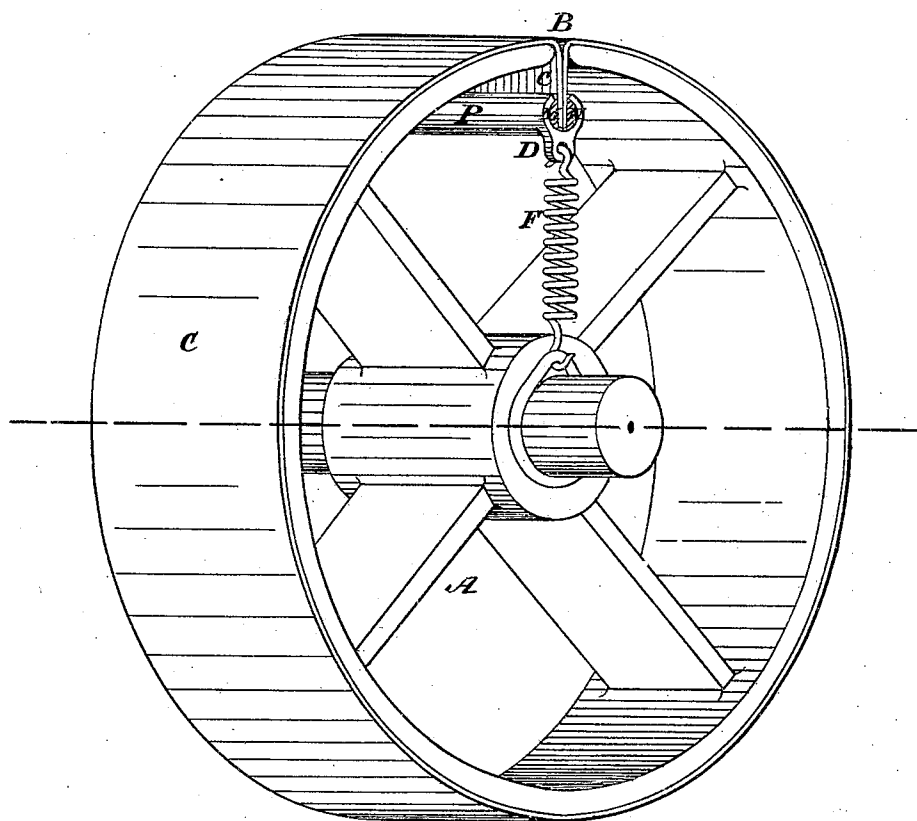

WITNESSES.

Edmund Edwards
Charles James Wintersgill

INVENTOR.

Richard John Edwards

R. J. EDWARDS.
Grinding and Polishing Wheels.

No. 134.134

Patented Dec. 24, 1872.

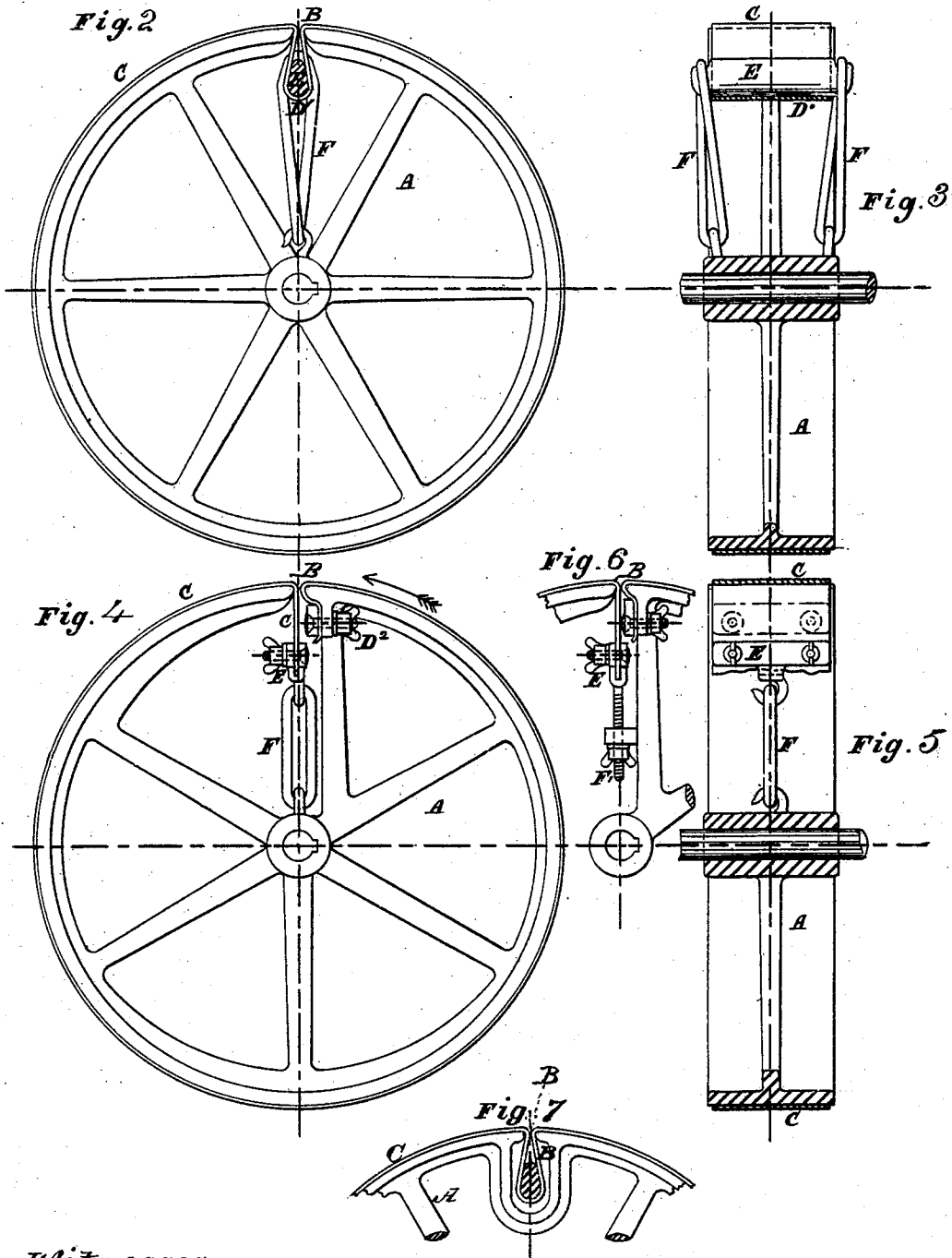

Witnesses.
Edmund Edwards
Charles James Wintersgill

Inventor.
Richard John Edwards

UNITED STATES PATENT OFFICE.

RICHARD JOHN EDWARDS, OF SHOREDITCH, ENGLAND.

IMPROVEMENT IN GRINDING AND POLISHING WHEELS.

Specification forming part of Letters Patent No. **134,134**, dated December 24, 1872; antedated December 18, 1872.

To all whom it may concern:

Be it known that I, RICHARD JOHN EDWARDS, of Shoreditch, in the county of Middlesex, England, have invented an Apparatus for Grinding and Polishing; and I do hereby declare that the following is a full, clear, and exact description thereof, reference being had to the accompanying drawing making part of this specification, in which—

Figure 1, Plate 1, is a perspective view of one form of grinding and polishing drum embodying my invention; Fig. 2, Plate 2, is a side view of a modification; Fig. 3, Plate 2, is a diametrical section of Fig. 2; Fig. 4, Plate 2, is a side elevation of another modification; Fig. 5, Plate 2, is a diametrical section of the same; Fig. 6, Plate 2, is a side elevation of a part of the drum or pulley shown in Fig. 4, showing a different method of arranging part of my invention; and Fig. 7, Plate 2, is a side elevation of part of the drum or pulley shown in Fig. 2, showing a different method of constructing the same.

Similar letters of reference indicate corresponding parts in the several figures.

In the accompanying drawing, A represents a drum or pulley, which is fixed upon an axis mounted in suitable bearings, and made to revolve by means of any suitable power. B is a transverse opening, made across the periphery of the drum in a suitable position. In Fig. 1, C is a band of cloth, covered with emery, glass, or other abrasive powder, the ends of which are passed through the opening B, and are held fast by a clip, D, which consists of two strips, M N, between which the cloth is placed; a slotted tube, P, is then passed over the strips M N, and springs F, of metal or India rubber, are attached to the ends of the slotted tube P for the purpose of keeping tight the band C. In Figs. 2 and 3, C is an endless band of cloth, covered with an abrasive powder, and of sufficient length to allow the loop D¹ to be drawn through the opening B. E is a rod or bar passed through the loop D¹, and drawn toward the center of the drum by means of India rubber or metal springs F F.

The operation of this device is as follows: The endless band C having been placed around the drum A, a part of it is drawn through the opening B so as to form the loop D¹, which

is stretched tight by means of the bar E and springs F F. By these means the band C is kept constantly tight when used for grinding, and can be readily replaced when required. When an endless band is not used the tightener shown in Fig. 1 may be adopted, or the plan represented in Figs. 4 and 5 may be adopted. In Figs. 4 and 5, C is the band of cloth, covered with an abrasive substance, one end of which is passed through the opening B, and is held fast in the clip or buckle D², and the other end is held in the movable clip or buckle E, which is drawn toward the center of the drum by means of the spring or springs F of India rubber or metal. In Fig. 6 the movable clip or buckle is shown drawn toward the center of the drum by means of a screw and nut, F', instead of a spring, F.

The operation of this modification is as follows: The band C having been placed around the drum A, and its end passed through the opening B, one end is fixed to the clip or buckle D², and the other end is fixed in the movable clip or buckle E, and is tightened by means of the spring or screw and nut F', which draws it toward the center of the drum. The band C can be readily removed or replaced even when it is not possible for an endless band to be passed over the drum. In Fig. 7, a recess, B, is shown in the periphery of the drum instead of an opening completely through, as shown in the other figures. By this method of construction the drum is not weakened as when the opening is made completely through.

To make the band C, I take cotton, linen, or other woven fabric of suitable length and width and of open texture, and on one or both sides of which I attach sheets of thin paper. I cover one side of each sheet of paper with flour-paste or other suitable cement, and, having placed it in contact with the woven fabric, I submit them to such heavy pressure that the paper is driven into the open texture of the latter. I then coat the woven fabric (which I sometimes cover with paste or cement) with glue, upon which, while soft, powdered emery, glass, or other suitable abrasive substance is spread. The paper renders the woven fabric more impervious to the glue or cement applied, as described.

The band C may be made in the form of a

rope or cord instead of flat. I make this by taking a suitable flexible cord or rope and coating it with glue or other suitable cement, on which I place powdered emery, glass, or other abrasive substance. I then allow the glue to cool and harden. In some cases I make bands C, whether endless or not, whether of flat or round material, with only a part of their surfaces covered with emery or glue, but having transverse depressions or spaces in which there is no abrasive substance.

I do not confine myself to the precise construction of the devices herein described for carrying my invention into effect, as other means equivalent thereto may be adopted which will operate substantially like them.

Having described my invention, what I claim as new is—

1. Grinding pulleys or drums made with

transverse openings B in their periphery for the purpose of adapting them to receive and confine the ends of flexible bands covered with abrasive substance, substantially as described.

2. Pulleys or drums having transverse openings B in their periphery, in combination with flexible bands covered with abrasive substance, substantially as described.

3. The combination, with the grinding-pulleys and flexible abrasive bands, of a tension device, substantially as described.

In testimony whereof I have signed my name to this specification in the presence of two subscribing witnesses.

RICHARD JOHN EDWARDS.

Witnesses:

EDMUND EDWARDS,

CHARLES JAMES WINTERSGILL.