

(19) World Intellectual Property Organization  
International Bureau



(43) International Publication Date  
15 June 2006 (15.06.2006)

PCT

(10) International Publication Number  
WO 2006/063338 A1

(51) International Patent Classification:  
B29C 45/16 (2006.01) F16L 55/17 (2006.01)

(21) International Application Number:  
PCT/US2005/044887

(22) International Filing Date:  
7 December 2005 (07.12.2005)

(25) Filing Language: English

(26) Publication Language: English

(30) Priority Data:  
60/634,209 8 December 2004 (08.12.2004) US

(71) Applicants and

(72) Inventors: KNAPP, Mark [US/US]; 3289 Lovers Lane,  
Ravenna, Ohio 44266 (US). SMITH, Jeffrey, Michael  
[US/US]; 661 Bellus Road, Hinckley, Ohio 44233 (US).

(74) Agent: YIRGA, John, A.; WATTS HOFFMANN CO.,  
L.P.A., PO Box 99839, Cleveland, Ohio 44199-0839 (US).

(81) Designated States (unless otherwise indicated, for every kind of national protection available): AE, AG, AL, AM, AT, AU, AZ, BA, BB, BG, BR, BW, BY, BZ, CA, CH, CN, CO, CR, CU, CZ, DE, DK, DM, DZ, EC, EE, EG, ES, FI, GB, GD, GE, GH, GM, HR, HU, ID, IL, IN, IS, JP, KE, KG, KM, KN, KP, KR, KZ, LC, LK, LR, LS, LT, LU, LV, LY, MA, MD, MG, MK, MN, MW, MX, MZ, NA, NG, NI, NO, NZ, OM, PG, PH, PL, PT, RO, RU, SC, SD, SE, SG, SK, SL, SM, SY, TJ, TM, TN, TR, TT, TZ, UA, UG, US, UZ, VC, VN, YU, ZA, ZM, ZW.

(84) Designated States (unless otherwise indicated, for every kind of regional protection available): ARIPO (BW, GH, GM, KE, LS, MW, MZ, NA, SD, SL, SZ, TZ, UG, ZM, ZW), Eurasian (AM, AZ, BY, KG, KZ, MD, RU, TJ, TM), European (AT, BE, BG, CH, CY, CZ, DE, DK, EE, ES, FI, FR, GB, GR, HU, IE, IS, IT, LT, LU, LV, MC, NL, PL, PT, RO, SE, SI, SK, TR), OAPI (BF, BJ, CF, CG, CI, CM, GA, GN, GQ, GW, ML, MR, NE, SN, TD, TG).

Published:  
— with international search report

[Continued on next page]

(54) Title: MOLDED GASKET AND METHOD OF MAKING

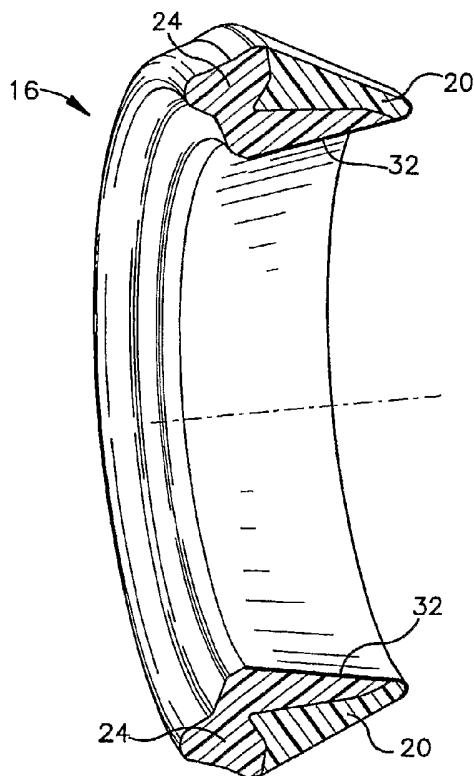

(57) Abstract: The present invention is directed to an annular gasket (16) for providing a fluid-tight seal between an inner pipe (14) and an outer pipe (12), when the pipes are in a relative surrounded and surrounding relationship. The gasket (16) includes a gasket portion configured to sealingly engage the inner and outer pipes when the pipes are in a relative surrounded and surrounding relationship. The gasket (16) includes a low coefficient of friction surface (32), which is applied to the gasket portion. The gasket (16) may be formed by a method in which a low coefficient of friction film (32) is inserted into a mold (51) before injection of compounds used to form the gasket (16).

WO 2006/063338 A1



- 
- *before the expiration of the time limit for amending the claims and to be republished in the event of receipt of amendments*
- For two-letter codes and other abbreviations, refer to the "Guidance Notes on Codes and Abbreviations" appearing at the beginning of each regular issue of the PCT Gazette.*

## MOLDED GASKET AND METHOD OF MAKING

CROSS-REFERENCES TO RELATED APPLICATIONS

The present application claims priority to U.S. Provisional Patent Application No. 60/634,209, entitled "*MOLDED GASKET AND METHOD OF MAKING*", filed December 8, 2004. The entirety of the aforementioned patent application is incorporated herein by reference for all purposes.

FIELD OF THE INVENTION

This invention relates generally to gaskets, and more particularly to gaskets including a low coefficient of friction surface.

BACKGROUND

It is well known to form a seal between two pipe sections, such as two corrugated pipe sections, where the end of one of the pipe sections has annular grooves and one of the pipe sections has an enlarged bell portion at one end. Some prior art elastomeric gaskets are placed around the end of the pipe section having annular grooves. The pipe section having annular grooves is inserted into an enlarged bell portion of a second pipe section. The elastomeric gasket contacts each of the pipe sections to form a seal between the pipe sections.

Typically, a large frictional force is encountered when the inner pipe and the elastomeric gasket is inserted into the outer pipe. As one end of the inner pipe is pushed into the enlarged end or bell of the outer pipe section or pipe connector, the gasket is sometimes pulled from the groove by the large frictional force. When the pipe is not properly sealed, ground water may leak into the pipe or fluid may leak out of the pipe and contaminate the ground.

Lubricant has been manually applied to elastomeric gaskets before the inner pipe and the gasket is inserted into the outer pipe. The lubricant reduces the frictional force between the gasket and the outer pipe. The reduced frictional force reduces the likelihood

that the gasket will be pulled from the groove by the frictional force. The manual application of the lubricant is labor intensive. In addition, the manually applied lubricant is wiped from the gasket if the pipe joint is disassembled. As a result, the lubricant must be reapplied before the pipe joint is reassembled.

Prior art methods have been developed that self lubricate gaskets as they are assembled. For example, U.S. Pat. No. 4,365,318 to Tolliver discloses a seal including a cavity containing a lubricant, which is released when one pipe joint is slid over the seal. U.S. Pat. No. 5,143,381 to Temple is directed to a seal, which has an internal chamber containing a lubricant. A slit in the body of the seal extends into the chamber. When one pipe is moved over another pipe end, the slit is spread, thereby releasing the lubricant against the sealing surface. U.S. Pat. No. 5,626,349 to Sutherland et al. concerns a sealing ring containing a lubricant enclosed within a membrane formed on the ring's body. When a connecting pipe is slid into the pipe joint, the membrane is ruptured, releasing the lubricant and reducing the frictional forces imparted on the sealing ring during the joining of the pipes. U.S. Pat. No. 5,735,528 to Olsson discloses a seal containing a lubricant. The lubricant migrates to the surface of the seal, thereby providing self-lubricating properties. Each of these methods provide the lubricant only the first time, or a limited number of times, the gasket forms a seal. The lubricant is eventually wiped off or spent. After the lubricant is wiped off or spent, a lubricant may need to be manually applied to ensure a proper seal.

There is a need for a gasket that includes a low coefficient of friction surface, which aids in the assembly and disassembly of pipe joints.

#### SUMMARY OF THE DISCLOSURE

The present invention is directed to an annular gasket for providing a fluid-tight seal between an inner pipe and an outer pipe, when the pipes are in a relative surrounded and surrounding relationship. The gasket includes a gasket portion configured to sealingly engage the inner and outer pipes when the pipes are in a relative surrounded and surrounding relationship. The gasket includes a low coefficient of friction surface, which is applied to the gasket portion.

In one embodiment, a low coefficient of friction material is applied to the gasket material as a film in a mold. In another embodiment, the low coefficient of friction material can be bonded to the gasket material. In certain cases, the low coefficient of friction material can be preformed into an annular ring prior to being applied to the gasket material. In alternate embodiments, the low coefficient of friction material may be thermally formed and bonded to the gasket material as in the known process of “thermoforming”.

The present invention is also directed to a coupling formed between two sections of piping. The coupling includes an outer pipe section and an inner pipe section, which extends into an end of the outer pipe section. A gasket is positioned between the outer pipe section and the inner pipe section to provide a fluid-tight seal between the two pipe sections. The gasket includes a gasket portion that sealingly engages each of the two sections of piping and a low coefficient of friction film applied to an exposed surface of the gasket portion.

One aspect of the invention is method of making a gasket having a low coefficient of friction surface for use in creating a seal between adjoining pipe sections. The method includes inserting a low coefficient of friction film into a mold cavity then injecting a gasket material into the mold cavity. The formed gasket is removed from the mold where the gasket includes a low coefficient of friction film on one of its exposed surfaces.

In one embodiment of the method, the low coefficient of friction film is preformed prior to insertion into the mold cavity. In another variation of the method, the low coefficient of friction material can be injected into the mold cavity. In one embodiment of the method, the injection includes a first injection of a material having a first durometer and a second injection of material having a second relatively lower durometer where the second durometer material forms a seal between two adjoining pipe sections when the gasket is in use. In one embodiment, the first material having a first durometer is adapted for being bonded to a first pipe section. Further, the first material, in an alternative embodiment, is a rigid material. In one embodiment, the second material is an elastomeric type material that can create a fluid tight seal between the adjoining pipe sections.

Another aspect of the invention is a method of making a gasket for creating a fluid-tight seal between adjoining pipe sections including injecting a low coefficient of friction material into the mold cavity. This first injection is cooled and is followed by an injection of a gasket type material. The molded gasket including a low coefficient of friction surface is then removed from the mold. Alternatively, the low coefficient of friction material is injected into the mold and is subsequently permitted to cool. Next a material having a first durometer is injected into the mold and is permitted to cool. A third material having a second relatively lower durometer is injected into the mold and permitted to cool. Finally, the molded gasket having a low coefficient of friction material and including two additional materials having different durometer is removed from the mold.

#### BRIEF DESCRIPTION OF THE DRAWINGS

Figure 1 is sectional view a portion of the annular gasket of the present invention;  
Figure 2 is a sectional view of a pipe joint including two pipe sections prior to coupling the pipe sections together;  
Figure 3 is a sectional view of the pipe joint of Figure 2 wherein the two pipe sections are in the coupled state;  
Figure 4 is a sectional view showing a low coefficient of friction film inserted into a mold;  
Figure 5 is a sectional view showing a gasket material injected into a mold;  
Figure 6 is a sectional view showing a gasket material and low coefficient of friction film in a mold;  
Figure 7 is a sectional view showing a gasket material and low coefficient of friction film in a mold;  
Figure 8 is a sectional view showing a second gasket material injected into a mold; and  
Figure 9 is a sectional view of a dual durometer gasket with a low coefficient of friction film.

DISCLOSURE OF THE INVENTION

Turning now to the Figures, Figure 1 illustrates an annular gasket 16 in accordance with the present invention. The illustrated gasket 16 includes three sections. A first section 20 is formed from a rigid material. A second section 24 is formed from a gasket type material that is less rigid than the first section and a third section 32 is formed from a low coefficient of friction material. Each section is described in more detail below.

Figure 2 and Figure 3 illustrate a pipe coupling 10 including the gasket. The coupling includes an outer pipe 12 and an inner pipe 14. The gasket 16 is situated in a sealing arrangement between the outer pipe 12 and inner pipe 14. In the illustrated embodiment, the outer pipe section 12 includes an annular recess or groove 18, which supports a portion of the gasket 16. It should be readily apparent that the annular recess or groove could be included in the inner pipe, rather than the outer pipe.

In the exemplary embodiment, the first section 20 is formed from a rigid material having a minimum Shore A hardness of 87 durometer. This portion of the gasket 16 can be bonded to the internal surface along the annular groove 18 of the outer pipe section 12 along an internal flat surface portion generally defined by reference number 22. Bonding of this rigid material to the internal surface of the outer pipe 12 can be accomplished by mechanical interference, spot welding, adhesive or other methods generally known to those of ordinary skill in the art. The bonding helps to hold the gasket in the annular groove 18 during assembly of the pipe coupling 10 as well as providing additional sealing properties between the gasket 16 and the outer pipe 12. Any thermoplastic meeting the described functioning will suffice, for example, polyolefin thermoplastics, including the polyolefin based, hard thermoplastic vulcanizates having polypropylene thermoplastic and dispersed, cross-linked ethylene-propylene-diene monomer rubber. The high Shore A and Shore D Santoprene<sup>®</sup> products of Advanced Elastomers Systems, L.P., having a principal place of business at 388 S. Main Street, Akron, OH 44311, are particularly suitable.

The second section 24 of the gasket 16 is formed from a material having a durometer relatively lower than that of the material of the first section 20 of the gasket 18. In one embodiment, the second section has about 55 Shore A durometer. The second

section 24 is bonded to the material of the first section 20 and extends from the first section 20 horizontally along the direction of the length of the outer pipe 12 to fill the annular groove 18 and making sealing contact with the internal surface of the annular groove 18. The material of the second section 24 is formed from an elastomeric gasket type material. Any elastomeric material for use in making gaskets could be used to make the second section of the gasket 16. The second section 24 of gasket material further extends radially inward from the outer pipe's internal surface towards the center of the pipe beyond the depth of the annular groove 18 in the outer pipe section 12. When the inner pipe 14 is coupled to the outer pipe 12, the second section 24 of the gasket becomes depressed to provide compression of the gasket 16 to aid in the sealing of the pipe coupling 10.

The third section 32 of material is cohered to the material of the second section 24. The material of the third section 32 is a material having a low coefficient of friction. The material is cohered to that portion of the second section 24, which first makes contact with the inner pipe 14 during assembly of the coupling 10. The low coefficient of friction material typically has a Shore D hardness of 40 or higher.

The low coefficient of friction material aids in assembly of the pipe coupling. By providing a surface having a lower coefficient of friction, the inner pipe section 14 can more easily be forced into the outer pipe section 12 having the gasket 16 present in its respective sealing location (i.e., annular groove 18) while providing a sealing engagement of the inner pipe section 14 with the gasket 16.

In Figure 2, the inner pipe section 14 is in a pre-coupling position. When the inner pipe 14 is forced into the outer pipe 12 having the gasket 16 installed, the inner pipe first makes contact with the low coefficient of friction surface 32 of the gasket 16. As the inner pipe 14 is forced onto the gasket 16, this low coefficient of friction portion 32 allows the inner pipe 14 to slide easily into the gasket 16. Figure 3 illustrates the inner pipe 14 completely inserted into the coupled position. As shown, the gasket 16 is compressed. This compression allows for the gasket 16 to apply force to the inner surface of the outer pipe 12 as well as force to the outer surface of the inner pipe 14 and, thus, provides a fluid tight seal. In the illustrated embodiment, the inner pipe, once coupled, is in sealing contact with the low coefficient of friction surface 32 along the inner

pipe's 14 external surface 19. This surface 19 sealingly engages the outer surface of the inner pipe 14 and the gasket 16. The external surface 19 contacts the low coefficient of friction section 32 of the gasket 16 and makes sealing contact at a joint generally shown by reference number 36. In an alternative embodiment, the low coefficient of friction surface 32 does not extend along the entire surface of the gasket that engages the inner pipe. The low coefficient of friction surface 32 may only extend partially along the surface that engages the inner pipe 14 to aid in the initial insertion of the inner pipe into the gasket. In this alternative embodiment, once the inner pipe 14 is inserted completely into the gasket, the second section 24 of gasket material contacts the surface 19. In this embodiment, sealing contact is provided with both the low coefficient of friction surface and the second section 24 of gasket material.

Figures 4-9 illustrate a method of producing a gasket with a low coefficient of friction film. Figure 4, illustrates placement of a low coefficient of friction film 32 into a mold cavity defined by a wall portion 56 of the center platen 54 of the mold 51. The mold cavity can be customized to define any desired shape of gasket. The film 32 is formed or cut to fit the profile of the injection mold cavity so that it covers the desired portion of the final molded gasket. In the exemplary embodiment, the low coefficient of friction film is preformed in long lengths and stored on a roll. An appropriate length of the film is cut from the roll prior to use. The film 32 is placed into the mold cavity via a robotic arm 58 having an electrostatic, mechanical or vacuum end that is used to place the film 32 into the cavity in the center platen 54 of the mold 51. The film 32 is held in place in the mold electro statically, mechanically, or by a vacuum. It is also contemplated that the film 32 can be secured in the mold by electrostatic means or by an injection of a small amount of material, which can temporarily hold the film in place until the final injection of the gasket is completed. The arm 58 extends into the mold cavity releasing the film 32 onto the mold cavity wall portion 56. In an alternative embodiment, the low coefficient of friction material is injected into the mold cavity or sprayed on the surface of the mold cavity. One material used for the low coefficient of friction film is sold under the name Santoprene<sup>®</sup> 103-40 and commercially available from Advanced Elastomer Systems. Alternate film materials such as polypropylene, polyethylene, polyacrylates, or other

engineering resin-based films having one or more layers are also suitable materials for achieving the desired physical properties.

Referring to Figure 5, the mold 51 is closed by relatively positioning platen 54a with respect to a center platen 54. The low coefficient of friction film 32 is held in the mold cavity of the center platen 54 by platen 54a. The stationary platen 54a includes a lip portion 55 that occupies a portion of the mold cavity so that after the first injection, a partial void remains when the stationary platen 54a is subsequently removed from the center platen 54. The lip portion 55 also holds the low coefficient of friction film in the center platen 54. The portion of the mold cavity unfilled by the lip 55 defines the first section 20 of the gasket 16, which is injected through a first injection port 56. The injection port 56 injects a rigid material into the unfilled portion of the mold cavity. One acceptable rigid material is sold under the name Exxpol Enhance 8224E1, an impact polypropylene copolymer, which is commercially available from Exxon Mobil Chemical having a place of business at 5000 Bayway Drive Baytown, TX 77520-2123, USA.

The process to prepare the material for injection is well known in the art.

Referring to Figure 6, the mold 51 is opened by separating the platen 54a from the center platen 54. The first injection of material forming the first section 20 of the gasket 16 remains in the mold cavity and is then permitted to cool. All the portions of the mold include water lines 53, which aid in rapid cooling of the injected material. A void remains between much of the film 32 and the injected rigid material. Referring to Figure 7, the mold 54 is then spun on its vertical axis communicate with a second platen 54c (See Fig. 7). To simplify the illustration of gasket 16, the second platen 54c is shown on the same side of the center platen 54 as the first platen 54a. After the first injection is cool, the center platen 54 is closed once again with the second platen 54c. The illustrated second platen 54c includes a concave void, defined by an internal wall 63 that will be filled with elastomeric gasket material and form the second section 24 of the gasket 16 along with the void created by the lip portion 55 of the platen 54a.

A second injection port 64 injects a gasket material into the mold cavity (as shown in Figure 8). The gasket material is material commonly used to form gaskets such as an elastomer, particularly a thermoplastic elastomer, and more particularly a dynamically vulcanized thermoplastic elastomer, which though formable as a

thermoplastic retains elastomeric properties. The durometer of the gasket type material is disclosed above and is relatively lower than that of the material of the first section 20.

Once the gasket material is injected, it is subsequently permitted to cool. Upon injection, the gasket material contacts both the first injected rigid material and the low coefficient of friction film. The rigid material and the film fuse to the gasket material in such a way that the final gasket appears as if it was molded in one injection. However, the gasket is defined by three different materials each having a different compositional makeup. One gasket material that can be used to form the second section 24 of the gasket through the second injection are the "soft" thermoplastic vulcanizates (Shore A durometer less than about 65) and are commercially available, e.g., Santoprene<sup>®</sup> 101-55W185 sold by Advanced Elastomer Systems, L.P.

As illustrated in Figure 9, the injected gasket material is cooled and the mold 51 is opened by separating the second platen 54c and the center platen 54. Upon separation, it is possible that the molded gasket 16 will remain in the center platen 54 of the mold 51. An ejector pin 60 may be used to aid in releasing the molded gasket 16 from the mold 54. The molded gasket 16 includes a first section 20 of rigid material, a second section 24 of gasket type material and a third section of low coefficient of friction film 32 which are all bonded together to form an integral gasket.

In an alternative embodiment, a low coefficient of friction film may be applied to the finished gasket. A first section of rigid material is injected into the mold and allowed to cool. Next, a second section of material having a relatively lower durometer is injected into the mold and cooled. The mold is then opened exposing a gasket having two sections. A low coefficient of friction film is then applied by spraying a low coefficient of friction material onto the gasket. One such low coefficient of friction material is a specially formulated ultraviolet cured material available from BASF Coatings AG. Once the film is applied to the gasket, it is permitted to "cure" thus becoming an integral low coefficient of friction film on a surface of the gasket. Unlike applying known lubricants to a gasket, the low coefficient of friction material adheres to the gasket eliminating the need to reapply the material.

While the invention has been described with a degree of particularity, it is the intent that the invention includes all modifications and alterations falling within the spirit and scope of the appended claims.

Claims

We claim:

1. A method for making gasket having a low coefficient of friction surface for use in creating a seal between adjoining pipe sections comprising the steps of:
  - a. inserting a film having a low coefficient of friction into a mold cavity;
  - b. injecting a gasket material into the mold cavity; and
  - c. removing the formed gasket from the mold cavity, said gasket including a low coefficient of friction film.
2. The method of claim 1 wherein the low coefficient of friction film is preformed.
3. The method of claim 1 wherein the injection comprises a first injection that of a material having a first durometer and a second injection of a material having a second relatively lower durometer that forms a seal between two adjoining pipe sections.
4. The method of claim 3 wherein the first material is adapted for bonding to a first pipe section.
5. The method of claim 3 wherein the second material is an elastomeric material for creating a fluid-tight seal between the adjoining pipe sections.
6. A method for making a gasket having a low coefficient of friction surface for use in creating a seal between adjoining pipe sections comprising the steps of:
  - a. inserting a pre-formed film having a low coefficient of friction into a mold cavity;
  - b. injecting material into the mold cavity; and
  - c. removing the formed gasket from the mold cavity, said gasket including a low coefficient of friction film.

7. The method of claim 6 wherein a first material having a first durometer and a second material having a second, relatively lower durometer are injected into the mold cavity.
8. The method of claim 7 wherein the first material is adapted to be bonded to a first pipe section.
9. The method of claim 7 wherein the second material is adapted to create a fluid-tight seal between the adjoining pipe sections.
10. A method for making a gasket having a low coefficient of friction surface for use in creating a seal between adjoining pipe sections comprising the steps of:
  - a. inserting a low coefficient of friction film into a mold cavity;
  - b. injecting a first material having a first durometer into the mold;
  - c. cooling the first material;
  - d. injecting a second material having a second, relatively lower durometer;
  - e. cooling the second material; and
  - f. ejecting the formed gasket having a low coefficient of friction film surface from the mold.
11. The method of claim 10 wherein the low coefficient of friction film is a pre-formed film.
12. A method for making a gasket for use in creating a seal between adjoining pipe sections comprising the steps of:
  - a. inserting a pre-formed low coefficient of friction film into a mold cavity;
  - b. injecting a first portion of rigid material into the mold;
  - c. allowing sufficient time to cool the first injection;
  - c. injecting a second portion of gasket material;
  - d. cooling the second portion of material; and
  - e. ejecting the formed gasket from the mold.

13. An annular gasket for providing a fluid-tight seal between an inner pipe and an outer pipe, when the pipes are in a relative surrounded and surrounding relationship, comprising:
- a. a gasket portion configured to sealingly engage the inner and outer pipes when the pipes are in a relative surrounded and surrounding relationship; and
  - b. a low coefficient of friction film permanently applied to an exposed surface of the gasket portion.
14. The gasket of claim 13 wherein the low coefficient of friction film is applied to the gasket portion in a mold.
15. The gasket of claim 13 wherein the low coefficient of friction film is bonded to the gasket portion.
16. The gasket of claim 13 wherein the low coefficient of friction film is applied to the gasket portion by spraying.
17. The gasket of claim 16 wherein said spray comprises UV cured systems, chemical or thermally cured systems.
18. The gasket of claim 13 wherein the low coefficient of friction film is preformed into an annular ring.
19. A molded annular gasket for providing a fluid-tight seal between an inner pipe and an outer pipe when the inner pipe and the outer pipe are in a relative surrounded and surrounding relationship, comprising:
- a. a gasket portion configured to sealingly engage the inner and outer pipes when the pipes are in a relative surrounded and surrounding relationship; and

- b. a pre-formed annular low coefficient of friction film molded to an outer surface of the gasket portion.
20. A coupling formed between two sections of corrugated piping, said coupling comprising:
- an outer pipe section;
  - an inner pipe section extending into an end of the outer pipe section; and
  - a annular gasket positioned between the outer pipe section and the inner pipe section to provide a fluid-tight seal between the outer pipe section and inner pipe section wherein the gasket comprises:
    - a. a gasket portion configured to sealingly engage an inner pipe section and an outer pipe section; and
    - b. a low coefficient of friction film applied to an exposed surface of the gasket portion.
21. A method for making a gasket having a low coefficient of friction surface for use in creating a fluid-tight seal between adjoining pipe sections comprising the steps of:
- a. injecting a first low coefficient of friction material into a mold cavity;
  - b. injecting a second gasket material into the mold cavity; and
  - c. removing the formed gasket from the mold cavity, said gasket including a low coefficient of friction surface.
22. The method of claim 21 wherein the injection of the second gasket material comprises a first injection of a first durometer material and a second injection of a second, relatively lower durometer material that forms a seal between two adjoining pipe sections.
23. A method for making a gasket having a low coefficient of friction surface for use in creating a fluid-tight seal between adjoining pipe sections comprising the steps of:
- a. injecting a first low coefficient of friction material into a mold cavity;
  - b. injecting a second material having a first durometer into the mold cavity;

- c. cooling the second material;
- d. injecting a third material having a second relatively lower durometer into the mold cavity;
- e. cooling the third material; and
- f. removing the formed gasket from the mold cavity, said gasket including a low coefficient of friction surface.

24. A method for making a gasket having a low coefficient of friction surface for use in creating a seal between adjoining pipe sections comprising the steps of:

- a. injecting a first material having a first durometer into the mold;
- b. cooling the first material;
- c. injecting a second material having a second, relatively lower durometer;
- d. cooling the second material;
- e. ejecting the formed gasket having a low coefficient of friction film surface from the mold; and
- f. applying a low coefficient of friction film to a surface of the gasket, said low coefficient of friction film being integrated with said surface of said gasket.

25. The method of claim 24 wherein said film is applied by spraying.

26. The method of claim 25 wherein said spray comprises UV cured systems, chemical or thermally cured systems.

27. An annular gasket for sealing adjoining pipe sections comprising:

- a. a first polymeric section circumscribing a first region of said annular gasket, said first polymeric section having a first durometer;
- b. a second polymeric section having a second durometer circumscribing a second region of said annular gasket, said second polymeric section being bonded with said first polymeric section; and

- c. a third polymeric section having a third durometer circumscribing a third region of said annular gasket, said third polymeric section being cohered with said second polymeric section;
- d. wherein said third polymeric section includes a low coefficient of friction region located along a portion of a section of said annular gasket that engages the a first corresponding pipe for aiding in the coupling of adjoining pipe sections.

28. The annular gasket of claim 27, wherein said first durometer of said first polymeric section is at least a Shore A 87 durometer.
29. The annular gasket of claim 27, wherein said second durometer of said second polymeric section is about Shore A 55 durometer.
30. The annular gasket of claim 27, wherein said third durometer of said third polymeric section is at least a Shore D 40 durometer.
31. The annular gasket of claim 27, wherein said low coefficient of friction region extends along the entire annular gasket section that engages said first corresponding pipe.
32. The annular gasket of claim 27, wherein said first polymeric section is a thermoplastic.
33. The annular gasket of claim 27, wherein said second polymeric section is an elastomer.
34. The annular gasket of claim 27, wherein said third polymeric section is a resin-based film.
35. The annular gasket of claim 27, wherein said third polymeric section is preformed into an annular ring.

36. The annular gasket of claim 27, wherein said first region of said annular gasket is adapted to seal an annular groove in a second corresponding pipe.

37. The annular gasket of claim 27, wherein said second region of said annular gasket is adapted to become partially compressed in said second polymeric section to aid in sealing said pipe joint.

38. A process of forming an annular gasket of three different polymeric materials comprising:

a. securing a first polymeric material having a low coefficient of friction into an interior cavity of a center mold;

b. creating a void in said interior cavity by connecting a first shaping mold with said center mold, said first shaping mold having an appendage that engages said center mold;

c. injecting a second polymeric material from said first shaping mold into a portion of said interior cavity in said center mold;

d. cooling said second polymeric material through a fluid jacket located within said first shaping and center molds;

e. retracting said first shaping mold from said center mold;

f. connecting a second shaping mold with said center mold;

g. injecting a third polymeric material from said second shaping mold into said void in the interior cavity created by said appendage, said third polymeric material is injected such that it bonds with said first and second polymeric materials;

h. cooling said third polymeric material through a fluid jacket located within said second shaping and center molds;

i. retracting said second shaping mold with said center mold to allow for the removal of the annular gasket; and

j. ejecting said annular gasket by an ejector pin passing through a front side of said center mold, said annular gasket having a low coefficient of friction film circumscribing a portion of said gasket surface.

39. The process of forming an annular gasket of claim 38, further comprising securing said first polymeric material by a robotic arm.

40. The process of forming an annular gasket of claim 38, further comprising securing said first polymeric material by an electrostatic charge.

41. The process of forming an annular gasket of claim 38, further comprising securing said first polymeric material by placing an adhesive between said first material and said mold cavity.

42. The process of forming an annular gasket of claim 38, further comprising securing said first polymeric material by vacuum holding arrangement.

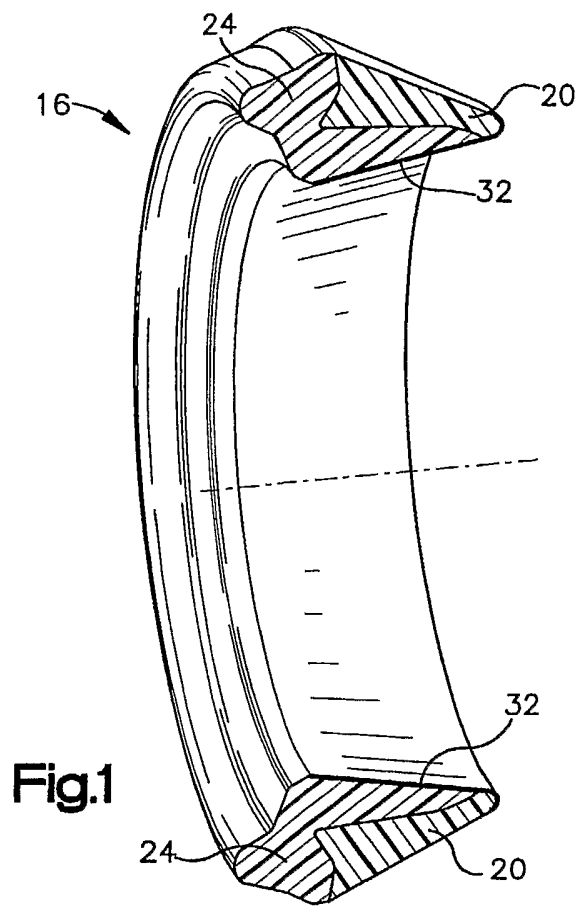

Fig.1

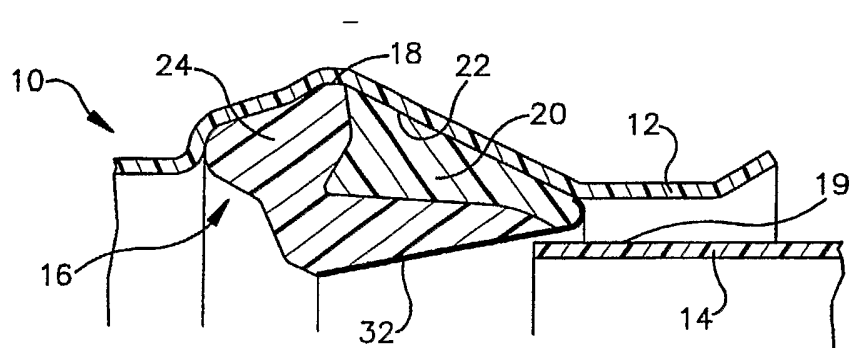

Fig.2

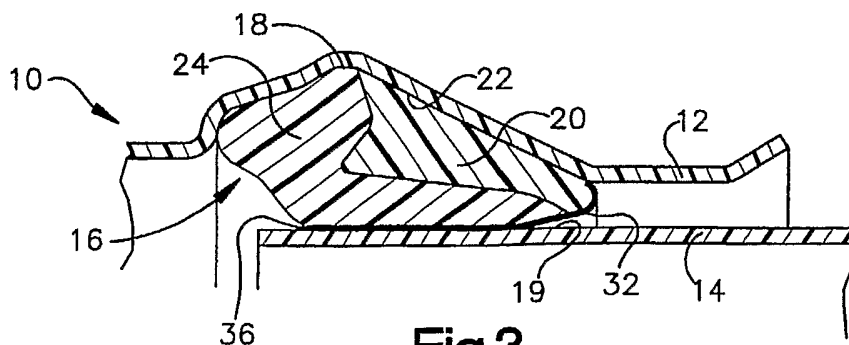
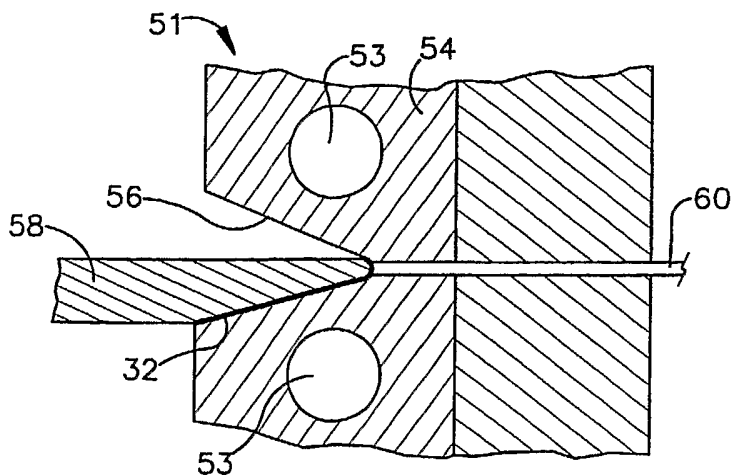
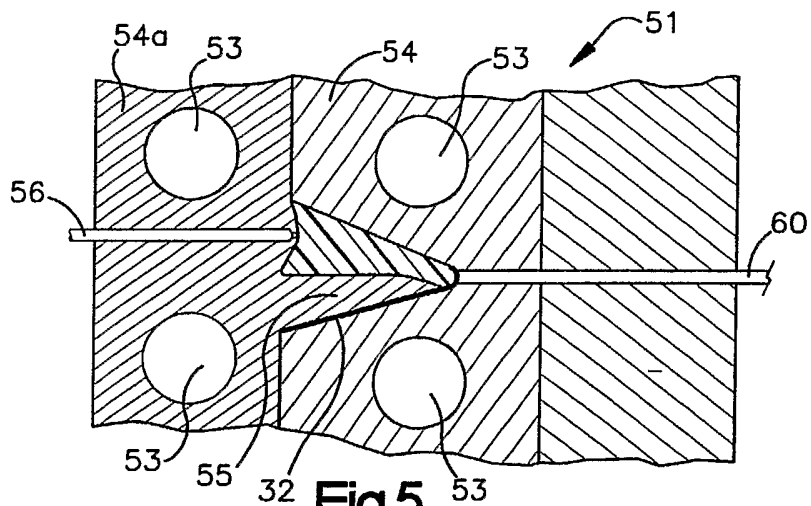

Fig.3



**Fig.4**



**Fig.5**

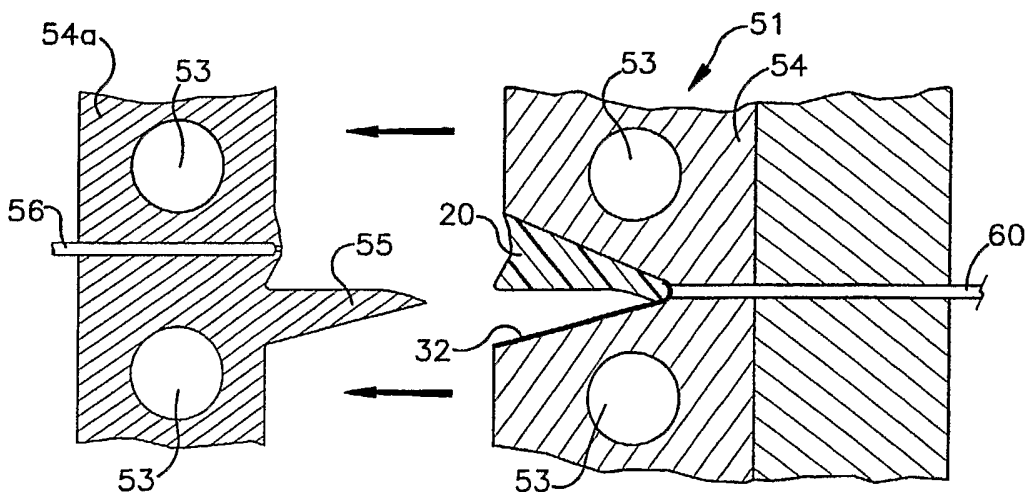

**Fig.6**

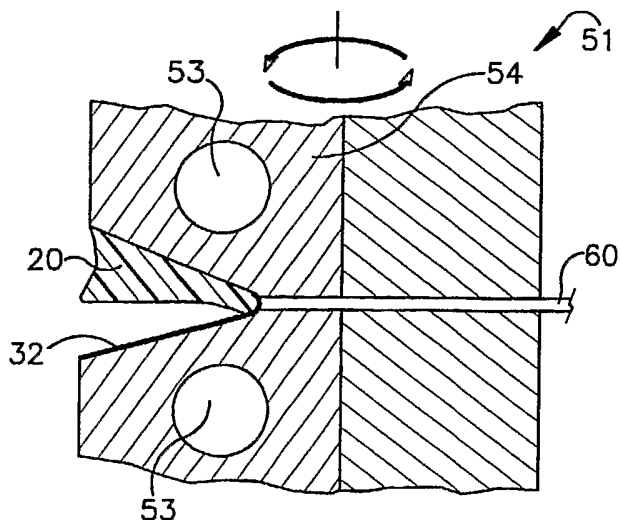

Fig.7

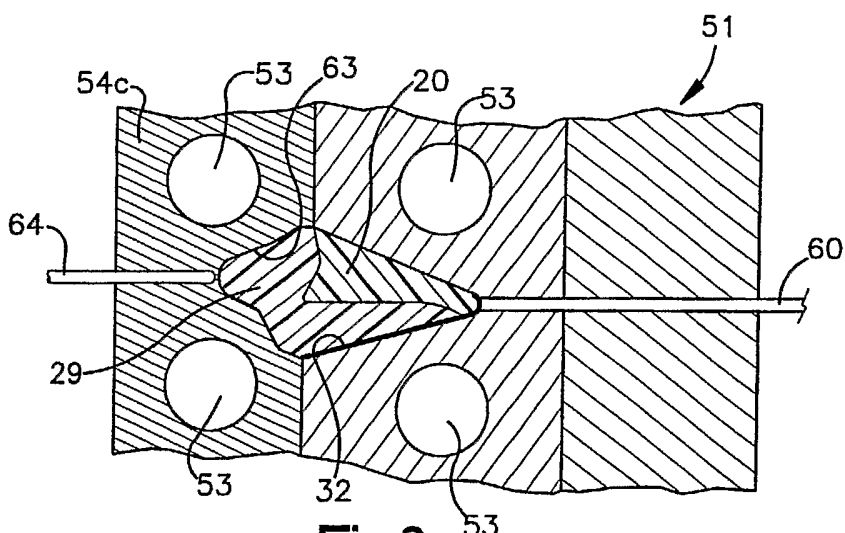

Fig.8

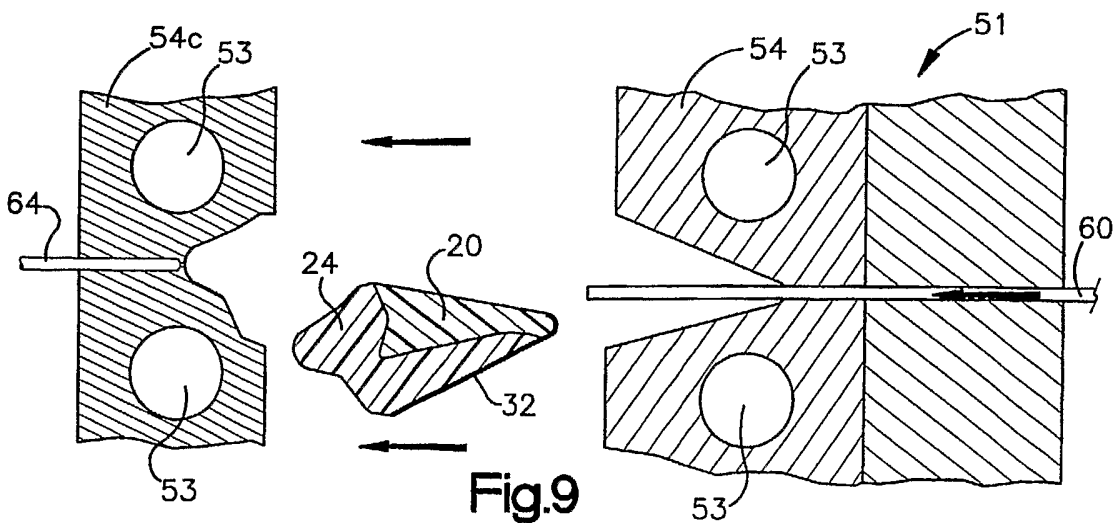

Fig.9

**INTERNATIONAL SEARCH REPORT**

International application No.

PCT/US05/44887

<p>A. CLASSIFICATION OF SUBJECT MATTER</p> <p>IPC: B29C 45/16( 2006.01);F16L 55/17( 2006.01)</p> <p>USPC: 264/259,257</p> <p>According to International Patent Classification (IPC) or to both national classification and IPC</p>																					
<p>B. FIELDS SEARCHED</p> <p>Minimum documentation searched (classification system followed by classification symbols) U.S. : 264/259, 257</p> <p>Documentation searched other than minimum documentation to the extent that such documents are included in the fields searched</p> <p>Electronic data base consulted during the international search (name of data base and, where practicable, search terms used)</p>																					
<p>C. DOCUMENTS CONSIDERED TO BE RELEVANT</p> <table border="1"> <thead> <tr> <th>Category *</th> <th>Citation of document, with indication, where appropriate, of the relevant passages</th> <th>Relevant to claim No.</th> </tr> </thead> <tbody> <tr> <td>X</td> <td rowspan="3">US 5346662 (BLACK et al) 13 September 1994 (13.09.1994), column 4, lines 44-68; column 5, lines 1-10; column 9, lines 40-62.</td> <td>1-2, 6, 7, 14-17, 21</td> </tr> <tr> <td>---</td> <td>-----</td> </tr> <tr> <td>Y</td> <td>3-5, 8-9, 13, 18-20, 22</td> </tr> <tr> <td>A</td> <td></td> <td>10-12, 23-42</td> </tr> <tr> <td>Y</td> <td>US 2578933 (HUNTER et al) 18 December 1951 (18.12.1951), figure 3; column 4, lines 6-75; column 5, lines 1-28.</td> <td>20</td> </tr> <tr> <td>Y</td> <td>US 4795166 (IRMLER) 3 January 1989 (03.01.1989), Figure 2A; column 1, lines 1-27, 54-68; column 2, lines 1-4, 34-35, 49-60.</td> <td>3-5, 8-9, 13, 18-19, 22</td> </tr> </tbody> </table>			Category *	Citation of document, with indication, where appropriate, of the relevant passages	Relevant to claim No.	X	US 5346662 (BLACK et al) 13 September 1994 (13.09.1994), column 4, lines 44-68; column 5, lines 1-10; column 9, lines 40-62.	1-2, 6, 7, 14-17, 21	---	-----	Y	3-5, 8-9, 13, 18-20, 22	A		10-12, 23-42	Y	US 2578933 (HUNTER et al) 18 December 1951 (18.12.1951), figure 3; column 4, lines 6-75; column 5, lines 1-28.	20	Y	US 4795166 (IRMLER) 3 January 1989 (03.01.1989), Figure 2A; column 1, lines 1-27, 54-68; column 2, lines 1-4, 34-35, 49-60.	3-5, 8-9, 13, 18-19, 22
Category *	Citation of document, with indication, where appropriate, of the relevant passages	Relevant to claim No.																			
X	US 5346662 (BLACK et al) 13 September 1994 (13.09.1994), column 4, lines 44-68; column 5, lines 1-10; column 9, lines 40-62.	1-2, 6, 7, 14-17, 21																			
---		-----																			
Y		3-5, 8-9, 13, 18-20, 22																			
A		10-12, 23-42																			
Y	US 2578933 (HUNTER et al) 18 December 1951 (18.12.1951), figure 3; column 4, lines 6-75; column 5, lines 1-28.	20																			
Y	US 4795166 (IRMLER) 3 January 1989 (03.01.1989), Figure 2A; column 1, lines 1-27, 54-68; column 2, lines 1-4, 34-35, 49-60.	3-5, 8-9, 13, 18-19, 22																			
<p><input type="checkbox"/> Further documents are listed in the continuation of Box C.      <input type="checkbox"/> See patent family annex.</p>																					
<p>* Special categories of cited documents:</p> <table border="0"> <tr> <td>"A" document defining the general state of the art which is not considered to be of particular relevance</td> <td>"T" later document published after the international filing date or priority date and not in conflict with the application but cited to understand the principle or theory underlying the invention</td> </tr> <tr> <td>"E" earlier application or patent published on or after the international filing date</td> <td>"X" document of particular relevance; the claimed invention cannot be considered novel or cannot be considered to involve an inventive step when the document is taken alone</td> </tr> <tr> <td>"L" document which may throw doubts on priority claim(s) or which is cited to establish the publication date of another citation or other special reason (as specified)</td> <td>"Y" document of particular relevance; the claimed invention cannot be considered to involve an inventive step when the document is combined with one or more other such documents, such combination being obvious to a person skilled in the art</td> </tr> <tr> <td>"O" document referring to an oral disclosure, use, exhibition or other means</td> <td>"&amp;" document member of the same patent family</td> </tr> <tr> <td>"P" document published prior to the international filing date but later than the priority date claimed</td> <td></td> </tr> </table>			"A" document defining the general state of the art which is not considered to be of particular relevance	"T" later document published after the international filing date or priority date and not in conflict with the application but cited to understand the principle or theory underlying the invention	"E" earlier application or patent published on or after the international filing date	"X" document of particular relevance; the claimed invention cannot be considered novel or cannot be considered to involve an inventive step when the document is taken alone	"L" document which may throw doubts on priority claim(s) or which is cited to establish the publication date of another citation or other special reason (as specified)	"Y" document of particular relevance; the claimed invention cannot be considered to involve an inventive step when the document is combined with one or more other such documents, such combination being obvious to a person skilled in the art	"O" document referring to an oral disclosure, use, exhibition or other means	"&" document member of the same patent family	"P" document published prior to the international filing date but later than the priority date claimed										
"A" document defining the general state of the art which is not considered to be of particular relevance	"T" later document published after the international filing date or priority date and not in conflict with the application but cited to understand the principle or theory underlying the invention																				
"E" earlier application or patent published on or after the international filing date	"X" document of particular relevance; the claimed invention cannot be considered novel or cannot be considered to involve an inventive step when the document is taken alone																				
"L" document which may throw doubts on priority claim(s) or which is cited to establish the publication date of another citation or other special reason (as specified)	"Y" document of particular relevance; the claimed invention cannot be considered to involve an inventive step when the document is combined with one or more other such documents, such combination being obvious to a person skilled in the art																				
"O" document referring to an oral disclosure, use, exhibition or other means	"&" document member of the same patent family																				
"P" document published prior to the international filing date but later than the priority date claimed																					
<p>Date of the actual completion of the international search 27 March 2006 (27.03.2006)</p>		<p>Date of mailing of the international search report <b>19 APR 2006</b></p>																			
<p>Name and mailing address of the ISA/US Mail Stop PCT, Attn: ISA/US Commissioner for Patents P.O. Box 1450 Alexandria, Virginia 22313-1450 Facsimile No. (571) 273-3201</p>		<p>Authorized officer Mike Colaianni <i>[Signature]</i> Telephone No. 571-272-1700</p>																			