



(12) **EUROPEAN PATENT APPLICATION**
 published in accordance with Art. 153(4) EPC

(43) Date of publication:
22.03.2017 Bulletin 2017/12

(51) Int Cl.:
F28F 1/32 (2006.01)

(21) Application number: **14892097.8**

(86) International application number:
PCT/JP2014/063003

(22) Date of filing: **15.05.2014**

(87) International publication number:
WO 2015/173938 (19.11.2015 Gazette 2015/46)

(84) Designated Contracting States:
AL AT BE BG CH CY CZ DE DK EE ES FI FR GB GR HR HU IE IS IT LI LT LU LV MC MK MT NL NO PL PT RO RS SE SI SK SM TR
 Designated Extension States:
BA ME

(72) Inventor: **TASHIRO, Yusuke**
Tokyo 100-8310 (JP)

(74) Representative: **Pfenning, Meinig & Partner mbB**
Patent- und Rechtsanwälte
Theresienhöhe 11a
80339 München (DE)

(71) Applicant: **Mitsubishi Electric Corporation**
Chiyoda-ku
Tokyo 100-8310 (JP)

(54) **HEAT EXCHANGER, AND REFRIGERATION CYCLE DEVICE PROVIDED WITH HEAT EXCHANGER**

(57) Fins 1 have a region L not provided with a heat transfer promoting portion 3 and a region other than the region L provided with the heat transfer promoting portion

3, and the region L is set to a region between a lower end portion of a heat transfer tube 2A and an upper end portion of a heat transfer tube 2B.

FIG. 3

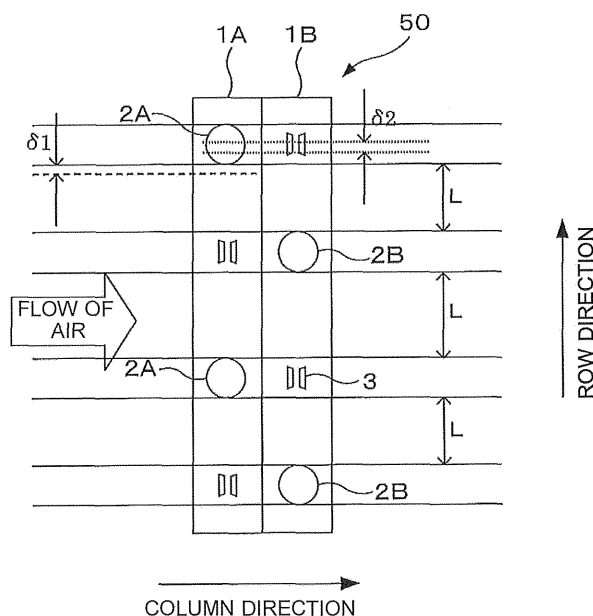

Description

Technical Field

[0001] The present invention relates to a heat exchanger installed in a heat source unit such as an outdoor unit and configured to minimize deterioration of frost formation resistance, and a refrigeration cycle apparatus including the heat exchanger.

Background Art

[0002] A plate fin-tube heat exchanger has been conventional as a heat exchanger applied to a refrigeration cycle apparatus, such as an air-conditioning apparatus. Such a heat exchanger is generally formed of a plurality of plate-shaped fins having circular holes and a plurality of heat transfer tubes having circular cross sections inserted through the fins.

[0003] As an example of such a heat exchanger, "a fin-tube heat exchanger including a plurality of heat transfer fins stacked substantially parallel to each other with predetermined gaps and a plurality of heat transfer tubes extending through the heat transfer fins in a direction substantially perpendicular to a planar direction of the heat transfer fins, the heat transfer tubes extending through through-holes in the heat transfer fins, substantially cylindrical fin collars being formed around the through-holes and extending in the direction substantially perpendicular to the planar direction of the heat transfer fins, and the heat transfer tubes being inserted through the through-holes while the heat transfer tubes being in close contact with the fin collars to exchange heat between gas flowing in the planar direction of the heat transfer fins and heat refrigerant flowing inside the heat transfer tubes, wherein slits are provided in the heat transfer fins only in a direction of rows substantially perpendicular to a flow direction of the gas, and wherein parts of the heat transfer fins upwind of the slits in flow of the gas are uplifted to provide projections having respective openings formed on a downwind side by the slits, with the projections not formed at positions crossing straight lines passing through the centers of the heat transfer tubes and parallel to the flow direction of the gas" has been proposed (see Patent Literature 1, for example).

[0004] Further, "a heat exchanger including heat transfer tubes 12, 12, ..., 12, 12, and ..., a multiple of heat transfer fins 13a, 13a, ..., 13b, 13b, and ... disposed side by side to cross the heat transfer tubes 12, 12, ..., 12, 12, and ..., and cut-and-raised pieces 14, 14, ..., 14, 14, and ... provided on heat transfer surfaces of the heat transfer fins 13a, 13a, ..., 13b, 13b, and ..., with lower end portions of the cut-and-raised pieces 14, 14, ..., 14, 14, and ... provided with linear portions b, b, ..., c, c, and ... for guiding condensed water extending toward the lower side" has been proposed (see Patent Literature 2, for example).

[0005] Further, "a heat exchanger including heat trans-

fer tubes, a plurality of heat transfer fins disposed side by side to cross the heat transfer tubes, and cut-and-raised pieces provided on heat transfer surfaces of the heat transfer fins, with lower end portions of the cut-and-raised pieces provided with water guiding portions for drainage" has been proposed (see Patent Literature 3, for example).

Citation List

Patent Literature

[0006]

Patent Literature 1: Japanese Patent No. 4775429 (Embodiment 1 and other sections)

Patent Literature 2: Japanese Unexamined Patent Application Publication No. 2008-249320 (Figs. 1 and 2 and other sections)

Patent Literature 3: Japanese Unexamined Patent Application Publication No. 2010-255974 (Figs. 1 and 2 and other sections)

Summary of Invention

Technical Problem

[0007] The fin-tube heat exchanger described in Patent Literature 1 is capable of obtaining excellent heat transfer performance by forming the projections, and secures drain passages for the condensed water and minimizes an increase in ventilation resistance by defining the areas in which the projections are not formed.

[0008] The heat exchangers described in Patent Literatures 2 and 3 improve the performance of the heat exchangers by enhancing heat transfer with cutouts, such as slits, provided between the heat transfer tubes, and are provided with devices, such as drain passages provided between the heat transfer tubes, to improve the drainage performance.

[0009] When a heating operation is performed with any of the thus-configured heat exchangers installed in a heat source unit such as an outdoor unit, the heat exchanger operates as an evaporator. Operating a heat exchanger as an evaporator may form frost on the heat exchanger. The frost formation on the heat exchanger occurs on leading edge portions of the fins (most upstream sides of the fins in flow of air) and fin slit portions, and also on parts of the heat transfer tubes. Further, the frost formation on the parts of the heat transfer tubes contributes to blockage of air passages.

[0010] In each of the heat exchangers described in Patent Literature 1 to 3, the projections or cutouts are provided in spaces between the heat transfer tubes, which serve as air release passages during the frost formation. Consequently, heat transfer is promoted, and the air release passages are blocked with grown frost during the frost formation.

[0011] In particular, when the formed frost grows in parts of the heat transfer tubes located on upstream sides of the air passages, the frost formation resistance deteriorates, and the air fails to reach the downstream side of the heat exchanger, preventing the heat exchange during the frost formation, that is, degrading the frost formation resistance.

[0012] The present invention has been made to solve the issues as described above, and aims to provide a heat exchanger that secures the air release passages during the frost formation to minimize the deterioration of the frost formation resistance, and a refrigeration cycle apparatus including the heat exchanger.

Solution to Problem

[0013] A heat exchanger according to an embodiment of the present invention includes a plurality of fins arranged parallel to each other with predetermined gaps therebetween, and a plurality of heat transfer tubes that extend through the fins. The fins have a multi-column configuration, and the plurality of heat transfer tubes are aligned in a multiple of rows along a direction perpendicular to a direction in which the fins are aligned in columns. When the columns are numbered in ascending order from a most upstream side of flow of air flowing through the heat exchanger, the plurality of heat transfer tubes include first heat transfer tubes that extend through the fins in a first column being one of the columns, and second heat transfer tubes that extend through the fins in a second column being another one of the columns and are positioned on upper sides and lower sides of the first heat transfer tubes in the direction in which the plurality of heat transfer tubes are aligned in the multiple of rows. The fins are provided with first regions in at least a part of which a heat transfer promoting portion is formed, and second regions in which the heat transfer promoting portion is not formed. Each of the second regions is included in at least one of a region between a lower end portion of one of the first heat transfer tubes and an upper end portion of one of the second heat transfer tubes closest to the one of the first heat transfer tubes, and a region between an upper end portion of another one of the first heat transfer tubes and a lower end portion of the one of the second heat transfer tubes closest to the other one of the first heat transfer tubes.

[0014] A refrigeration cycle apparatus according to an embodiment of the present invention includes a heat source unit equipped with the above-described heat exchanger and a use-side unit connected to the heat source unit. **Advantageous Effects of Invention**

[0015] The heat exchanger according to the embodiment of the present invention has the second regions provided in the fins, and thus is capable of securing the air release passages during the frost formation and minimizing the deterioration of the frost formation resistance.

[0016] The refrigeration cycle apparatus according to the embodiment of the present invention includes the

above-described heat exchanger, and thus is capable of continuously performing the operation without blockage of the air passages in the heat exchanger even during the frost formation on the heat exchanger.

Brief Description of Drawings

[0017]

[Fig. 1] Fig. 1 is a perspective view schematically illustrating an internal configuration of a heat source unit installed with an example of a heat exchanger according to Embodiment 1 of the present invention.

[Fig. 2] Fig. 2 is an explanatory diagram for describing the configuration of the heat source unit installed with the example of the heat exchanger according to Embodiment 1 of the present invention.

[Fig. 3] Fig. 3 is a schematic diagram schematically illustrating a state of the example of the heat exchanger according to Embodiment 1 of the present invention, as viewed in the direction of central axes of heat transfer tubes.

[Fig. 4] Fig. 4 is a schematic diagram schematically illustrating a state of another example of the heat exchanger according to Embodiment 1 of the present invention, as viewed in the direction of the central axes of the heat transfer tubes.

[Fig. 5] Fig. 5 is a schematic diagram schematically illustrating a state of another example of the heat exchanger according to Embodiment 1 of the present invention, as viewed in the direction of the central axes of the heat transfer tubes.

[Fig. 6] Fig. 6 is a schematic diagram schematically illustrating a state of the heat exchanger according to Embodiment 1 of the present invention, as viewed in a direction perpendicular to the direction of the central axes of the heat transfer tubes.

[Fig. 7] Fig. 7 is a schematic explanatory diagram for describing an example of specific numerical values of the heat exchanger according to Embodiment 1 of the present invention.

[Fig. 8] Fig. 8 is a refrigerant circuit diagram schematically illustrating a basic refrigerant circuit configuration of a refrigeration cycle apparatus according to Embodiment 2 of the present invention.

Description of Embodiments

[0018] Embodiment 1 and Embodiment 2 of the present invention will be described below with reference to the drawings as necessary. In the following drawings including Fig. 1, the dimensional relationships between component members may be different from actual ones. Further, in the following drawings including Fig. 1, parts assigned with the same reference signs are the same or correspond to one another, and the reference signs are applied to the entire text of the specification. Further, forms of component elements described in the entire text

of the specification are only illustrative, and the present invention is not limited to these described forms.

Embodiment 1

[0019] Fig. 1 is a perspective view schematically illustrating an internal configuration of a heat source unit 60 installed with an example of a heat exchanger according to Embodiment 1 of the present invention (hereinafter referred to as the heat exchanger 50). Fig. 2 is an explanatory diagram for describing the configuration of the heat source unit 60. The configuration of the heat source unit 60 will first be described with reference to Figs. 1 and 2.

[0020] The heat source unit (also referred to as outdoor unit) 60 forms a part of a refrigeration cycle apparatus. The heat source unit 60 is connected to an indoor unit (also referred to as use-side unit or load-side unit) to thereby form the refrigeration cycle apparatus. Further, component devices mounted in the heat source unit 60 and the indoor unit (a compressor, a heat source-side heat exchanger (the heat exchanger 50), an expansion device (an expansion valve 12), and a use-side heat exchanger 71) are connected by pipes to thereby form a refrigerant circuit and perform an air-conditioning operation or a hot water supply operation, for example. The refrigeration cycle apparatus will be described in Embodiment 2.

[0021] The heat source unit 60 includes a housing 60A forming an exterior. As illustrated in Figs. 1 and 2, a divider 61 is provided inside the housing 60A. With the divider 61, the interior of the housing 60A is demarcated into a mechanical chamber 62 and an air-sending device chamber 63.

[0022] The mechanical chamber 62 is provided with a compressor 10, a four-way valve 11, the expansion valve 12, a muffler 16, refrigerant pipes 15 for connecting these devices, and other devices.

[0023] The air-sending device chamber 63 is provided with the heat exchanger 50, an air-sending fan 20, a fan motor 21, a motor support 22, and other devices.

[0024] Details of the components provided in the mechanical chamber 62 and the air-sending device chamber 63 will be described below.

[0025] The compressor 10 compresses refrigerant circulating through a refrigeration cycle into high-temperature, high-pressure refrigerant, and discharges the compressed refrigerant.

[0026] The four-way valve 11 switches a flow of the refrigerant depending on the operation. When a heating energy supply operation of supplying heating energy to the load side is performed, the four-way valve 11 is switched as indicated by a solid line in Fig. 2. When a cooling energy supply operation of supplying cooling energy to the load side is performed, the four-way valve 11 is switched as indicated by a broken line in Fig. 2.

[0027] The expansion valve 12 expands the refrigerant by reducing the pressure, and is formed of a valve con-

trollable to change the opening degree, such as an electronic expansion valve.

[0028] The muffler 16 has a role of stabilizing the flow rate of the refrigerant by accumulating a certain amount of gas refrigerant and then distributing the refrigerant to the compressor 10.

[0029] The heat exchanger 50 is a cross-fin, fin-and-tube heat exchanger. Details of the heat exchanger 50 will be described later. The heat exchanger 50 is formed into a substantially L-shape in a plan view. A heat exchange area of the heat exchanger 50 can be increased by forming the heat exchanger 50 into the substantially L-shape.

[0030] The air-sending fan 20 is an air-sending unit formed of an axial-flow fan (propeller fan), for example.

[0031] The fan motor 21 is for rotating the air-sending fan 20. The fan motor 21 is supported by the motor support 22.

[0032] The motor support 22 is a member supporting the fan motor 21.

[0033] An operation of the heat source unit 60 during the heating energy supply operation will be described.

[0034] When the compressor 10 is driven, the refrigerant is increased in pressure and discharged in a high-temperature, high-pressure state by the compressor 10. The refrigerant discharged from the compressor 10 passes through the four-way valve 11, and then is supplied to the heat exchanger mounted in the indoor unit, illustration of which is omitted, to be cooled into a low-temperature, high-pressure state through heat exchange with air. In this process, air for heating is supplied from the indoor unit, and an air-conditioned space is heated. The refrigerant returns to the heat source unit 60, and is expanded through pressure reduction by the expansion valve 12 into a low-temperature, low-pressure state. The refrigerant is heated by the heat exchanger 50, and then returns to the compressor 10.

[0035] When the refrigeration cycle apparatus performs the heating energy supply operation (a heating operation, for example), the heat exchanger 50 operates as an evaporator in the heat source unit 60. Operating the heat exchanger 50 as an evaporator may form frost on the heat exchanger 50. As described above, the frost formation on the heat exchanger 50 also occurs on parts of heat transfer tubes in addition to leading edge portions of fins and fin slit portions. When the formed frost grows, air passages are eventually blocked.

[0036] In general, a cross-fin, fin-and-tube heat exchanger has fins formed with heat transfer promoting portions, such as slits, to produce a heat transfer promotion effect. Such heat transfer promoting portions promote heat transfer, allowing frost to block even air release passages desired to be secured during the frost formation. In particular, when the formed frost grows in parts of the heat transfer tubes located on upstream sides of the air passages, the air fails to reach the downstream side of the heat exchanger, preventing the heat exchange during the frost formation. That is, the frost formation resistance

of the heat exchanger is substantially degraded. Consequently, the heat exchanger 50 adopts the following configuration.

[0037] Fig. 3 is a schematic diagram schematically illustrating a state of an example of the heat exchanger 50, as viewed in the direction of central axes of the heat transfer tubes. Fig. 4 is a schematic diagram schematically illustrating a state of another example of the heat exchanger 40, as viewed in the direction of the central axes of the heat transfer tubes. Fig. 5 is a schematic diagram schematically illustrating a state of another example of the heat exchanger 50, as viewed in the direction of the central axes of the heat transfer tubes. Fig. 6 is a schematic diagram schematically illustrating a state of the heat exchanger 50, as viewed in a direction perpendicular to the direction of the central axes of the heat transfer tubes. Fig. 7 is a schematic explanatory diagram for describing an example of specific numerical values of the heat exchanger 50. The heat exchanger 50 will be described in detail with reference to Figs. 3 to 7. As examples, Figs. 3 and 4 illustrate the heat exchanger 50 having a two-column configuration, and Fig. 5 illustrates the heat exchanger 50 having a three-column configuration.

[0038] As illustrated in Fig. 5, the heat exchanger 50 includes a plurality of fins 1 arranged parallel to each other with predetermined gaps and a plurality of heat transfer tubes 2 that extend through the fins 1, and exchanges heat between the air flowing between the fins 1 and the refrigerant flowing inside the heat transfer tubes 2.

[0039] The plurality of fins 1 are arranged in a direction parallel to the direction of flow of air, and have a multi-column configuration.

[0040] Fig. 3 illustrates the fin 1 disposed on the upstream side of the flow of air as a fin 1A and the fin 1 disposed on the downstream side of the flow of air as a fin 1B. That is, the fins 1 have a two-column configuration in the example illustrated in Fig. 3.

[0041] Fig. 5 illustrates the fin 1 disposed on the upstream side of the flow of air as the fin 1A, the fin 1 disposed on the downstream side of the flow of air as a fin 1C, and the fin 1 disposed between the fin 1A and the fin 1C as the fin 1B. That is, the fins 1 have a three-column configuration in the example illustrated in Fig. 5.

[0042] The direction parallel to the direction of the flow of air is defined as the "column direction."

[0043] When columns are numbered in ascending order from the most upstream side of the flow of air flowing through the heat exchanger 50, the fin 1A corresponds to a "fin in the first column."

[0044] When columns are numbered in ascending order from the most upstream side of the flow of air flowing through the heat exchanger 50, the fin 1B corresponds to a "fin in the second column."

[0045] The plurality of heat transfer tubes 2 are provided in a direction perpendicular to the direction of the flow of air through the fins 1.

[0046] Fig. 3 illustrates the heat transfer tubes 2 extending through the fin 1A as heat transfer tubes 2A, and the heat transfer tubes 2 extending through the fin 1B as heat transfer tubes 2B. That is, the heat transfer tubes 2 are aligned in a multiple of rows in the example illustrated in Fig. 3. That is, the heat transfer tubes 2 are aligned in a multiple of rows along a direction perpendicular to the column direction of the fins 1.

[0047] Fig. 5 illustrates the heat transfer tubes 2 extending through the fin 1A as the heat transfer tubes 2A, the heat transfer tubes 2 extending through the fin 1B as the heat transfer tubes 2B, and the heat transfer tubes 2 extending through the fin 1C as heat transfer tubes 2C. That is, the heat transfer tubes 2 are aligned in a multiple of rows in the example illustrated in Fig. 5.

[0048] The direction perpendicular to the direction of the flow of air is defined as the "row direction." Further, the heat transfer tubes 2A correspond to "first heat transfer tubes" of the present invention, and the heat transfer tubes 2B correspond to "second heat transfer tubes" of the present invention.

[0049] Further, in the heat exchanger 50, a heat transfer promoting portion such as a slit is not provided between preceding and following ones of the heat transfer tubes 2 in the fins 1 to minimize the frost formation on parts of the air passages serving as ultimate release passages during the frost formation. The preceding and following ones of the heat transfer tubes 2 refer to, with reference to one of the heat transfer tubes 2A on the most upstream side of the flow of air for heat exchange, the heat transfer tube 2A and one or two of the heat transfer tubes 2B closest to the heat transfer tube 2A and positioned on the upper side and/or the lower side of the heat transfer tube 2A. That is, in the heat exchanger 50, the heat transfer promoting portion is not provided in a region between a lower end portion of one of the heat transfer tubes 2A and an upper end portion of the corresponding one of the heat transfer tubes 2B and a region between an upper end portion of one of the heat transfer tubes 2A and a lower end portion of the corresponding one of the heat transfer tubes 2B (three regions (second regions) L illustrated in Figs. 3 and 5).

[0050] However, the heat exchanger 50 illustrated in Fig. 5 has the three-column configuration, and thus the regions L are extended in the column direction, and the heat transfer promoting portion is also not provided between a lower end portion of one of the heat transfer tubes 2C and an upper end portion of the corresponding one of the heat transfer tubes 2B. The region L is set to a region including at least a central portion of the region between the lower end portion of the one of the heat transfer tubes 2A and the upper end portion of the corresponding one of the heat transfer tubes 2B.

[0051] Meanwhile, in the heat exchanger 50, the heat transfer promoting portion 3 such as a slit for producing the heat transfer promotion effect is formed in each of regions of the fins 1 not including the region L (first regions). In each of the regions of the fins 1 not including

the region L, however, the heat transfer promoting portion 3 may be formed, and is not necessarily required to be formed. In the regions of the fins 1 not including the region L, the heat transfer promoting portion 3 is formed in a region of $\delta 2$ described below.

[0052] With this configuration, the heat exchanger 50 can secure the region L as the air release passage, even when the formed frost grows. In particular, when the formed frost grows on parts of the heat transfer tubes 2A, the region L serves as the air release passage, and thus the air reaches the downstream side of the heat exchanger 50, and the heat exchange continues. Consequently, the heat exchanger 50 is capable of minimizing the deterioration of the frost formation resistance.

[0053] Meanwhile, in the heat exchanger 50, the heat transfer promoting portion 3 may be formed in each of the regions not including the region L, and when the heat transfer promoting portion 3 is formed, the heat transfer is promoted.

[0054] Although Figs. 3 and 5 illustrate, as an example, the case in which the region L extends parallel to the column direction, the region L is not required to extend strictly parallel to the column direction. For example, the region L may be secured to slope from the upstream side toward the downstream side of the flow of air. With this configuration, the region L also serves as a drain passage when the frost thaws. That is, the region L is only required to include a central portion of the region between the lower end portion of one of the heat transfer tubes 2A (the heat transfer tubes 2C) and the upper end portion of the corresponding one of the heat transfer tubes 2B and a central portion of the region between the upper end portion of one of the heat transfer tubes 2A (the heat transfer tubes 2C) and the lower end portion of the corresponding one of the heat transfer tubes 2B, and the region L may or may not extend parallel to the column direction.

[0055] Further, the region L may be provided on a part. For example, as illustrated in Fig. 4, the region between the heat transfer tube 2A in the uppermost row and the heat transfer tube 2B in the uppermost row may be set as the region L. Alternatively, although not illustrated, the region between the heat transfer tube 2A in the lowermost row and the heat transfer tube 2B in the lowermost row may be set as the region L. That is, the number of regions L is not particularly limited. However, the deterioration of the frost formation resistance can be further reduced by setting the region L on both the upper sides and the lower sides of the heat transfer tubes, as in Figs. 3 and 5. Further, when the region between the heat transfer tube 2A in the lowermost row and the heat transfer tube 2B in the lowermost row is set as the region L, the drainage performance is enhanced owing to the absence of the heat transfer promoting portion 3, and the post-defrost drainage performance is improved.

[0056] Further, in configuring the heat exchanger 50, the size of the region L is preferably determined in consideration of a stagnation region length ($\delta 1$) around each

of the heat transfer tubes 2. In a portion of $\delta 1$, the amount of formed frost is originally small owing to the separation of flow of air from a leading edge portion of the heat transfer tube 2. That is, the region L is set to the area excluding the portion of $\delta 1$. This configuration can form the heat transfer promoting portion 3 in the portion of $\delta 1$, and the heat transfer is promoted in the portion of $\delta 1$. As for the width, the region L can secure the air release passage.

[0057] Further, in configuring the heat exchanger 50, the regions other than the region L, that is, the regions in each of which the heat transfer promoting portion 3 is formed, is preferably determined in consideration of a stagnation region length ($\delta 2$) of a slipstream behind each of the heat transfer tubes 2. A portion of $\delta 2$ is a slipstream portion behind the heat transfer tube 2, in which air originally does not flow smoothly. That is, the heat transfer promoting portion 3 is not formed in the region L, but is formed in each of the regions including $\delta 2$. With this configuration, the heat transfer promoting portion 3 is formed in the portion of $\delta 2$, and the heat transfer is promoted in the portion of $\delta 2$. As for the width, the region L can secure the air release passage. The region L in this case may or may not include $\delta 1$.

[0058] As described above, in the heat exchanger 50, forming the region L secures the air release passage during the frost formation and minimizes the deterioration of the frost formation resistance. In the heat exchanger 50, consequently, the air passage is not blocked even during the frost formation, and thus the operation can be continued.

Embodiment 2

[0059] Fig. 8 is a refrigerant circuit diagram schematically illustrating a basic refrigerant circuit configuration of a refrigeration cycle apparatus 100 according to Embodiment 2 of the present invention. A configuration and operation of the refrigeration cycle apparatus 100 will be described with reference to Fig. 8. The refrigeration cycle apparatus 100 includes the heat source unit 60 and an indoor unit 70, and is capable of performing a heating energy supply operation (a heating operation, for example) or a cooling energy supply operation (a cooling operation, for example) by circulating refrigerant through component devices mounted in the heat source unit 60 and the indoor unit 70. In Embodiment 2, the same parts as those in Embodiment 1 are assigned with the same reference signs, and the description of the same parts will be omitted.

[0060] The indoor unit (also referred to as use-side unit or load-side unit) 70 forms a part of the refrigeration cycle apparatus 100 together with the heat source unit 60. Further, the component devices mounted in the heat source unit 60 and the indoor unit 70 (the compressor 10, the heat exchanger 50, the expansion valve 12, and the use-side heat exchanger 71) are connected by pipes to thereby form a refrigerant circuit. For example, the refrigeration cycle apparatus 100 is used in performing an air-

conditioning operation in an air-conditioned space (such as an indoor space installed with the indoor unit 70). Further, for example, the refrigeration cycle apparatus 100 is used in performing a hot water supply operation of boiling water with the use-side heat exchanger 71. In Embodiment 2, however, a description will be given in the assumption that the refrigeration cycle apparatus 100 performs the air-conditioning operation.

[0061] The heat source unit 60 is as described in Embodiment 1.

[0062] The indoor unit 70 is equipped with the use-side heat exchanger 71 and an air-sending fan 72.

[0063] The use-side heat exchanger (also referred to as indoor heat exchanger or load-side heat exchanger) 71 may be formed of a cross-fin, fin-and-tube heat exchanger similarly to the heat exchanger 50. When heat is exchanged with water, brine, or another material, however, the use-side heat exchanger 71 may be formed of a microchannel heat exchanger, a shell-and-tube heat exchanger, a heat-pipe heat exchanger, a double-pipe heat exchanger, a plate heat exchanger, or another type of heat exchanger. A case in which the use-side heat exchanger 71 exchanges heat with air and refrigerant will be described here as an example.

[0064] The air-sending fan 72 is an air-sending unit formed of a through-flow fan (cross-flow fan), for example.

[0065] The air-conditioning operation of the refrigeration cycle apparatus 100 will be described.

[Heating Operation]

[0066] When the compressor 10 is driven, the refrigerant is increased in pressure and discharged in a high-temperature, high-pressure state by the compressor 10. The refrigerant discharged from the compressor 10 is supplied to the use-side heat exchanger 71 and cooled into a low-temperature, high-pressure state through heat exchange with air. In this process, air for heating is supplied from the indoor unit 70, and the air-conditioned space is heated. The refrigerant flows out of the use-side heat exchanger 71 and is expanded through pressure reduction by the expansion valve 12 into a low-temperature, low-pressure state. The refrigerant is heated by the heat exchanger 50, and then returns to the compressor 10.

[Cooling Operation]

[0067] When the compressor 10 is driven, the refrigerant is increased in pressure and discharged in a high-temperature, high-pressure state by the compressor 10. The refrigerant discharged from the compressor 10 is supplied to the heat exchanger 50 and cooled into a low-temperature, high-pressure state through heat exchange with air. The refrigerant flows out of the heat exchanger 50, and is expanded through pressure reduction by the expansion valve 12 into a low-temperature, low-pressure

state. The refrigerant is heated by the use-side heat exchanger 71. In this process, air for cooling is supplied from the indoor unit 70, and the air-conditioned space is cooled. The refrigerant flowing out of the use-side heat exchanger 71 returns to the compressor 10.

[0068] As described above, the refrigeration cycle apparatus 100 includes the heat exchanger 50, and thus is capable of securing the air release passages even during the frost formation and minimizing the deterioration of the frost formation resistance. Further, the air passages of the heat exchanger 50 are not blocked even during the frost formation on the heat exchanger 50, and thus the refrigeration cycle apparatus 100 is capable of continuously performing the heating energy supply operation.

[0069] The numerical values described in Embodiment 1 are only illustrative, and the present invention is not limited to the described numerical values. Reference Signs List

[0070] 1 fin 1A fin 1B fin 1C fin 2 heat transfer tube 2A heat transfer tube 2B heat transfer tube 2C heat transfer tube 3 heat transfer promoting portion 10 compressor 11 four-way valve 12 expansion valve 15 refrigerant pipe 16 muffler 20 air-sending fan 21 fan motor 22 motor support 50 heat exchanger 60 heat source unit 60A housing 61 divider 62 mechanical chamber 63 air-sending device chamber 70 indoor unit 71 use-side heat exchanger 72 air-sending fan 100 refrigeration cycle apparatus L region

30

Claims

1. A heat exchanger comprising a plurality of fins arranged parallel to each other with predetermined gaps therebetween, and a plurality of heat transfer tubes that extend through the fins, the fins having a multi-column configuration, and the plurality of heat transfer tubes being aligned in a multiple of rows along a direction perpendicular to a direction in which the fins are aligned in columns, the plurality of heat transfer tubes including:

35

40

45

50

55

when the columns are numbered in ascending order from a most upstream side of flow of air flowing through the heat exchanger, first heat transfer tubes that extend through the fins in a first column being one of the columns; and second heat transfer tubes that extend through the fins in a second column being an other one of the columns and are positioned on upper sides and lower sides of the first heat transfer tubes in the direction in which the plurality of heat transfer tubes are aligned in the multiple of rows, wherein the fins are provided with first regions in at least a part of which a heat transfer promoting portion is formed, and second regions in

which the heat transfer promoting portion is not formed, and
 each of the second regions is included in at least one of a region between a lower end portion of one of the first heat transfer tubes and an upper end portion of one of the second heat transfer tubes closest to the one of the first heat transfer tubes, and a region between an upper end portion of an other one of the first heat transfer tubes and a lower end portion of the one of the second heat transfer tubes closest to the other one of the first heat transfer tubes.

5

10

2. The heat exchanger of claim 1, wherein each of the first regions is independent of the second regions.

15

3. The heat exchanger of claim 1 or 2, wherein each of the second regions includes at least a central portion of the region between the lower end portion of the one of the first heat transfer tubes and the upper end portion of the one of the second heat transfer tubes closest to the one of the first heat transfer tubes.

20

4. The heat exchanger of claim 1 or 2, wherein each of the second regions includes at least a central portion of the region between the upper end portion of the other one of the first heat transfer tubes and the lower end portion of the one of the second heat transfer tubes closest to the other one of the first heat transfer tubes.

25

30

5. The heat exchanger of any one of claims 1 to 4, wherein each of the second regions is a region excluding a stagnation region around the plurality of heat transfer tubes.

35

6. The heat exchanger of any one of claims 1 to 5, wherein each of the first regions is a region including a stagnation region of a slipstream behind the plurality of heat transfer tubes and having at least the heat transfer promoting portion.

40

7. A refrigeration cycle apparatus comprising:
 a heat source unit equipped with the heat exchanger of any one of claims 1 to 6; and
 a use-side unit connected to the heat source unit.

45

50

55

FIG. 1

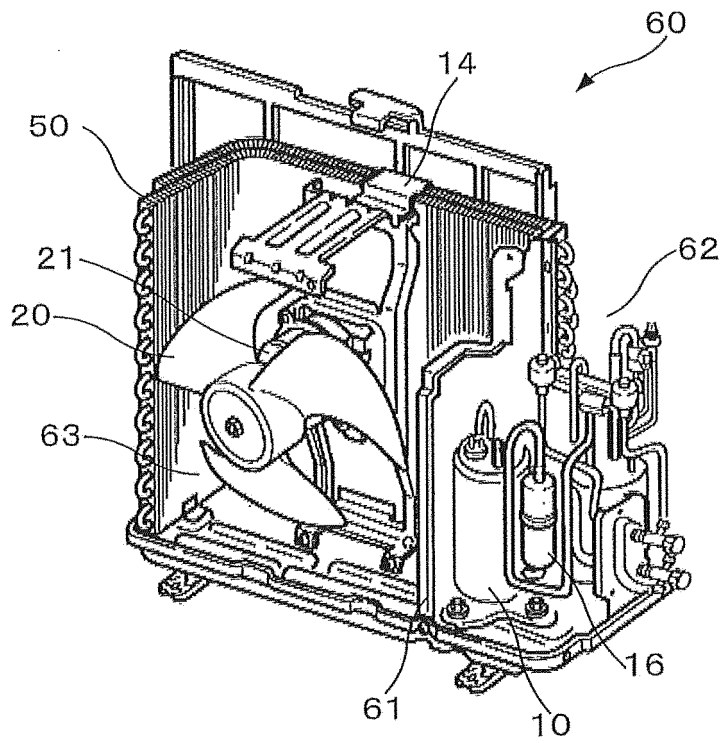

FIG. 2

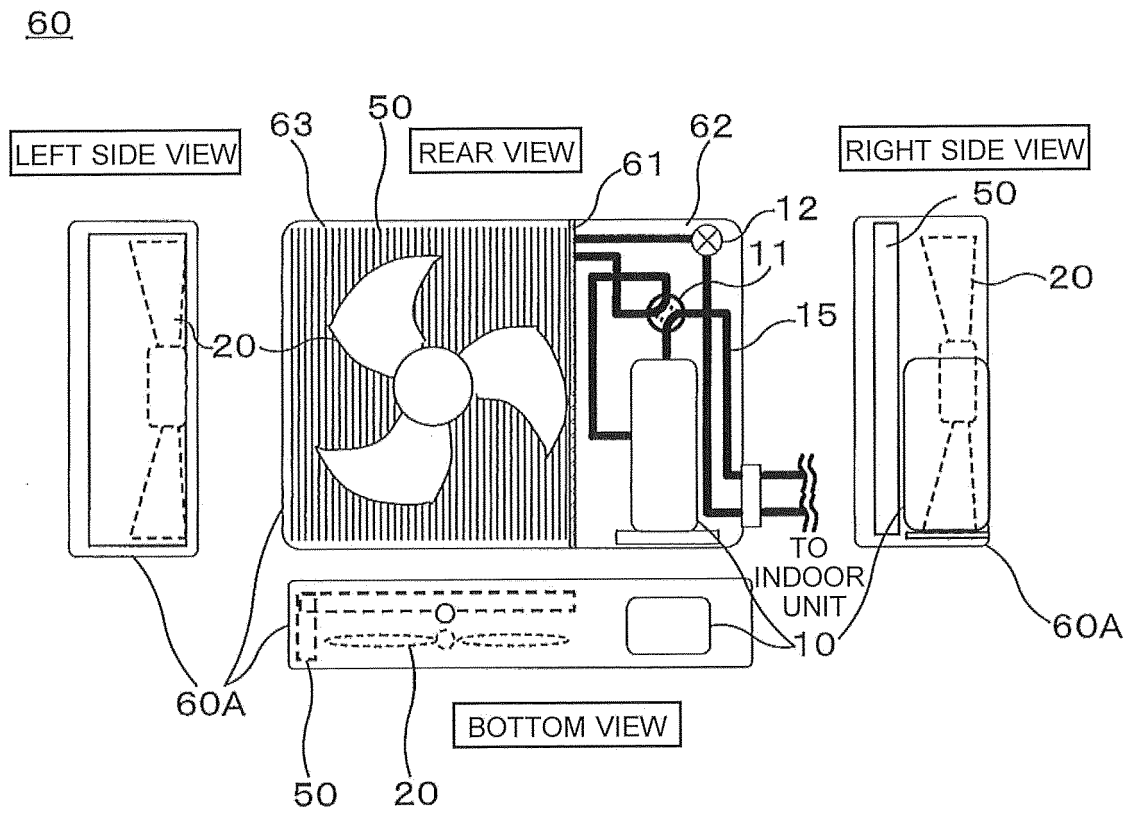

FIG. 3

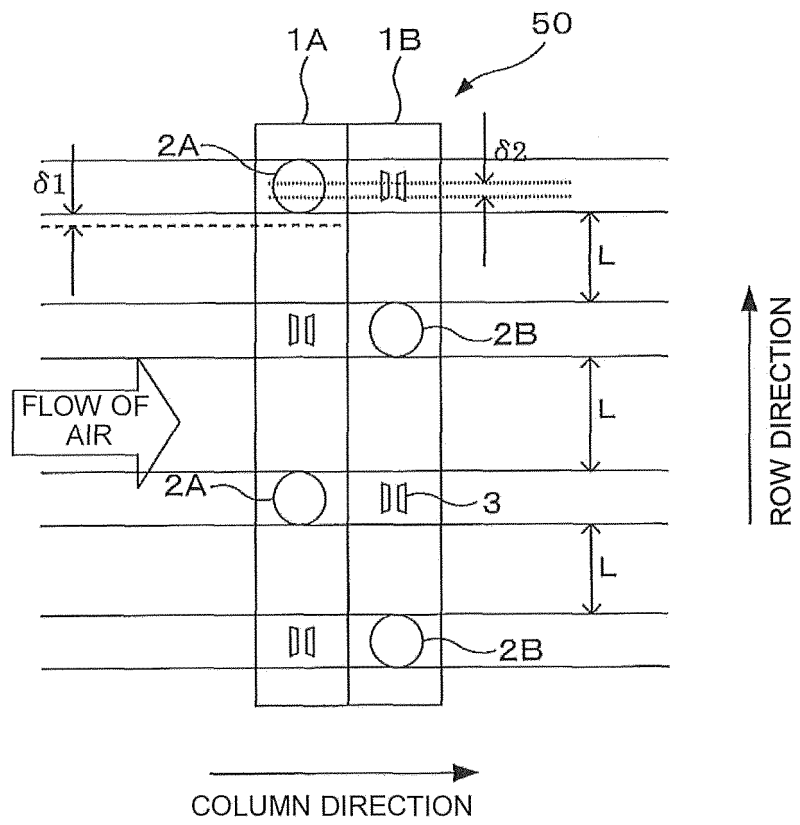

FIG. 4

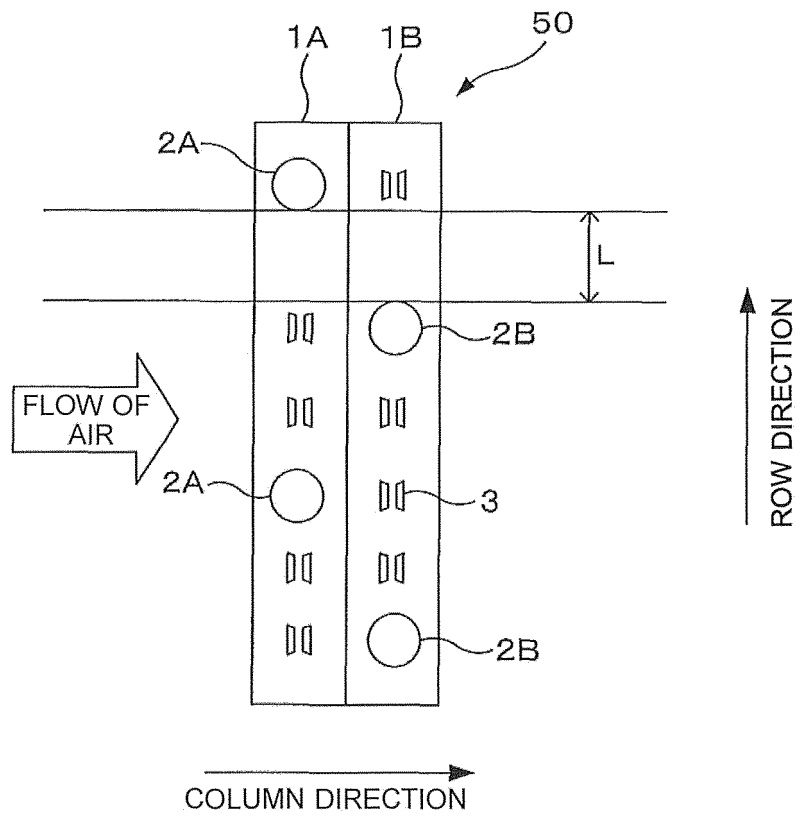

FIG. 5

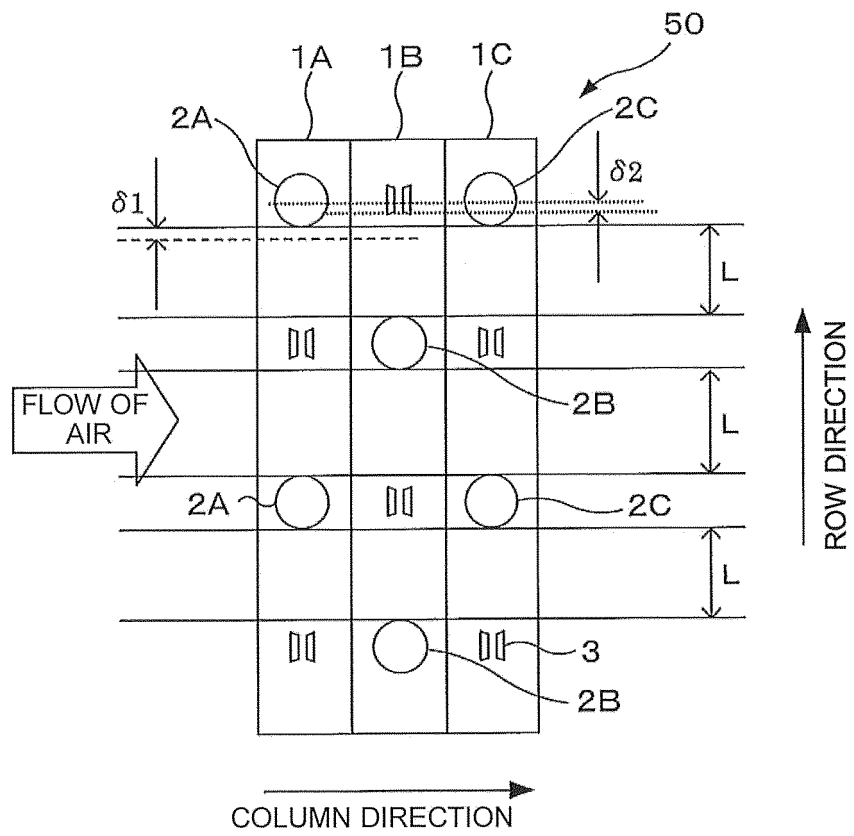

FIG. 6

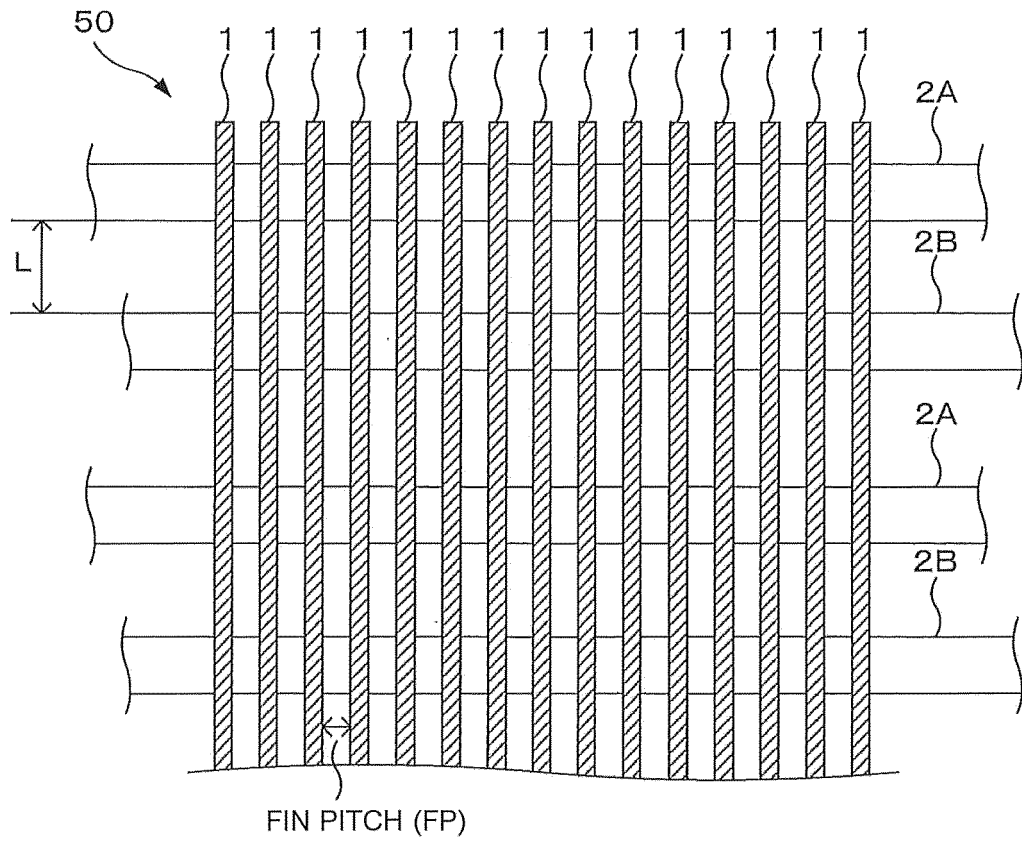
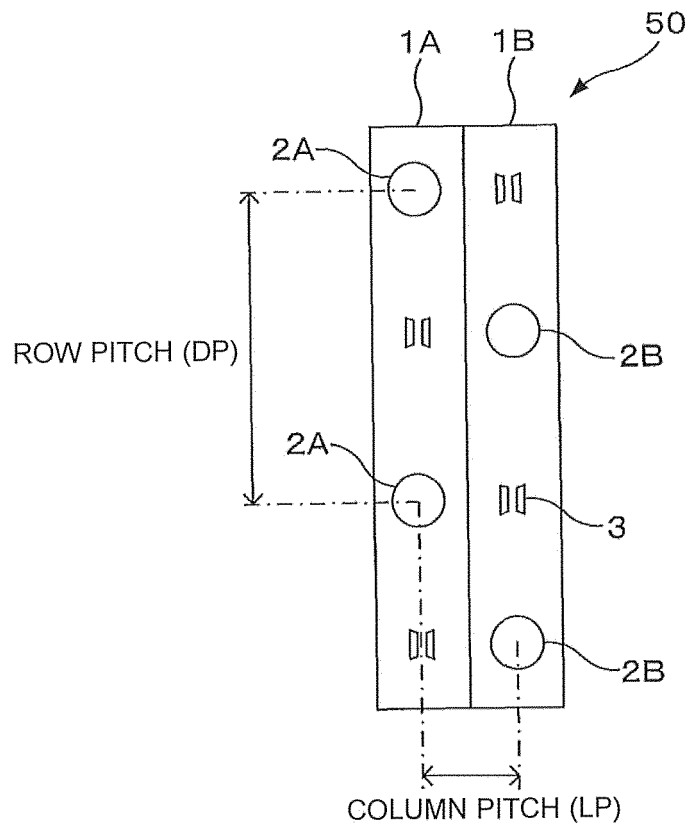

FIG. 7



INTERNATIONAL SEARCH REPORT

International application No.

PCT/JP2014/063003

| | | |
|----|---|--|
| 5 | A. CLASSIFICATION OF SUBJECT MATTER F28F1/32(2006.01)i | |
| | According to International Patent Classification (IPC) or to both national classification and IPC | |
| 10 | B. FIELDS SEARCHED | |
| | Minimum documentation searched (classification system followed by classification symbols) F28F1/32 | |
| 15 | Documentation searched other than minimum documentation to the extent that such documents are included in the fields searched Jitsuyo Shinan Koho 1922-1996 Jitsuyo Shinan Toroku Koho 1996-2014 Kokai Jitsuyo Shinan Koho 1971-2014 Toroku Jitsuyo Shinan Koho 1994-2014 | |
| | Electronic data base consulted during the international search (name of data base and, where practicable, search terms used) | |
| 20 | C. DOCUMENTS CONSIDERED TO BE RELEVANT | |
| | Category* | Citation of document, with indication, where appropriate, of the relevant passages |
| 25 | Y | JP 2008-249320 A (Daikin Industries, Ltd.), 16 October 2008 (16.10.2008), claims; fig. 1 & US 2010/0089562 A1 |
| 30 | Y | JP 2010-255974 A (Daikin Industries, Ltd.), 11 November 2010 (11.11.2010), claims; fig. 1 (Family: none) |
| 35 | Y | JP 2012-163320 A (Daikin Industries, Ltd.), 30 August 2012 (30.08.2012), paragraphs [0026], [0027], [0043]; fig. 13 to 16 & WO 2012/098919 A1 |
| 40 | <input type="checkbox"/> Further documents are listed in the continuation of Box C. <input type="checkbox"/> See patent family annex. | |
| 45 | * Special categories of cited documents: | "T" later document published after the international filing date or priority date and not in conflict with the application but cited to understand the principle or theory underlying the invention |
| | "A" document defining the general state of the art which is not considered to be of particular relevance | "X" document of particular relevance; the claimed invention cannot be considered novel or cannot be considered to involve an inventive step when the document is taken alone |
| | "E" earlier application or patent but published on or after the international filing date | "Y" document of particular relevance; the claimed invention cannot be considered to involve an inventive step when the document is combined with one or more other such documents, such combination being obvious to a person skilled in the art |
| | "L" document which may throw doubts on priority claim(s) or which is cited to establish the publication date of another citation or other special reason (as specified) | "&" document member of the same patent family |
| | "O" document referring to an oral disclosure, use, exhibition or other means | |
| | "P" document published prior to the international filing date but later than the priority date claimed | |
| 50 | Date of the actual completion of the international search 28 May, 2014 (28.05.14) | Date of mailing of the international search report 10 June, 2014 (10.06.14) |
| 55 | Name and mailing address of the ISA/ Japanese Patent Office | Authorized officer |
| | Facsimile No. | Telephone No. |

Form PCT/ISA/210 (second sheet) (July 2009)

REFERENCES CITED IN THE DESCRIPTION

This list of references cited by the applicant is for the reader's convenience only. It does not form part of the European patent document. Even though great care has been taken in compiling the references, errors or omissions cannot be excluded and the EPO disclaims all liability in this regard.

Patent documents cited in the description

- JP 4775429 B [0006]
- JP 2008249320 A [0006]
- JP 2010255974 A [0006]