

(19) World Intellectual Property Organization
International Bureau



(43) International Publication Date
9 June 2005 (09.06.2005)

PCT

(10) International Publication Number
WO 2005/051209 A1

(51) International Patent Classification⁷: A61B 17/17

(21) International Application Number:
PCT/US2004/038931

(22) International Filing Date:
19 November 2004 (19.11.2004)

(25) Filing Language: English

(26) Publication Language: English

(30) Priority Data:
60/523,799 20 November 2003 (20.11.2003) US

(71) Applicant (for all designated States except US):
WRIGHT MEDICAL TECHNOLOGY, INC. [US/US];
5677 Airline Road, Arlington, TN 38002-9501 (US).

(72) Inventors; and

(75) Inventors/Applicants (for US only): SHELDON,
Michael, B. [US/US]; 1060 Mirror Lake Lane, Cordova,

TN 38018-7871 (US). LUNA, Ramon [US/US]; 4360
Cleopatra Road, Memphis, TN 38128-1472 (US). SEYER,
Steven, F. [US/US]; 8021 Sunny Creek Drive, German-
town, TN 38138-2340 (US). KREHLIK, Brian [US/US];
3012 Vicwood Drive, Murfreesboro, TN 37128-5819 (US).

(74) Agent: SENTILLES, Shawn, D.; Wright Medical Tech-
nology, Inc., 5677 Airline Road, Arlington, TN 38002-
9501 (US).

(81) Designated States (unless otherwise indicated, for every
kind of national protection available): AE, AG, AL, AM,
AT, AU, AZ, BA, BB, BG, BR, BW, BY, BZ, CA, CH, CN,
CO, CR, CU, CZ, DE, DK, DM, DZ, EC, EE, EG, ES, FI,
GB, GD, GE, GH, GM, HR, HU, ID, IL, IN, IS, JP, KE,
KG, KP, KR, KZ, LC, LK, LR, LS, LT, LU, LV, MA, MD,
MG, MK, MN, MW, MX, MZ, NA, NI, NO, NZ, OM, PG,
PH, PL, PT, RO, RU, SC, SD, SE, SG, SK, SL, SY, TJ, TM,
TN, TR, TT, TZ, UA, UG, US, UZ, VC, VN, YU, ZA, ZM,
ZW.

[Continued on next page]

(54) Title: GUIDE CLAMP FOR GUIDING PLACEMENT OF A GUIDE WIRE IN A FEMUR

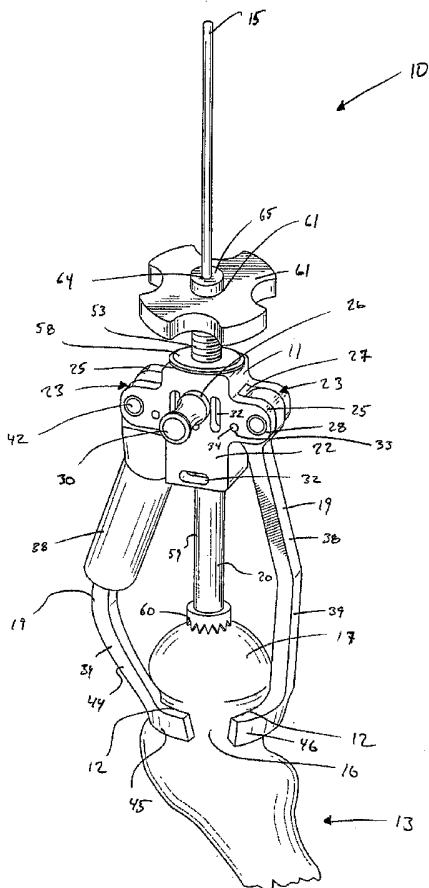

(57) Abstract: A guide clamp (10) for clamping a femur and guiding place-
ment of a guide wire relative to the femur. The guide clamp includes a
body (11) supporting a pair of clamping surfaces (12) at the end of a pair
of clamping arms (19) that are spring-biased to move with respect to
each other into a closed position to grip the femur. Defined by the body is a
guide opening (14) that guides insertion of the guide pin (15) once the femur
has been gripped. One of the clamping arms (19) of the guide clamp may
have proximal and distal portions that are slidably adjustable with respect
to each other to allow a controlled repositioning of the guide opening with
respect to the femur. The guide clamp may also include an engagement
member (20) which is supported by the body of the clamp and is capable of
advancing into abutting contact with the head of the femur.

WO 2005/051209 A1



(84) **Designated States** (unless otherwise indicated, for every kind of regional protection available): ARIPO (BW, GH, GM, KE, LS, MW, MZ, NA, SD, SL, SZ, TZ, UG, ZM, ZW), Eurasian (AM, AZ, BY, KG, KZ, MD, RU, TJ, TM), European (AT, BE, BG, CH, CY, CZ, DE, DK, EE, ES, FI, FR, GB, GR, HU, IE, IS, IT, LU, MC, NL, PL, PT, RO, SE, SI, SK, TR), OAPI (BF, BJ, CF, CG, CI, CM, GA, GN, GQ, GW, ML, MR, NE, SN, TD, TG).

For two-letter codes and other abbreviations, refer to the "Guidance Notes on Codes and Abbreviations" appearing at the beginning of each regular issue of the PCT Gazette.

Published:

— with international search report

GUIDE CLAMP FOR GUIDING PLACEMENT
OF A GUIDE WIRE IN A FEMUR

5

CROSS REFERENCE TO RELATED APPLICATIONS

This application claims priority to United States Provisional Patent
Application Serial No. 60/523,799, filed November 20, 2003, which is pending.

10

BACKGROUND OF THE INVENTION

Field of the Invention

The present invention is related to the use of guides for placement of guide
wires in orthopedic surgery, and more particularly to the use of a guide clamp for
placement of a guide wire during femoral head resurfacing surgery.

15

Description of Related Art

When severe hip joint problems are encountered, it is sometimes necessary to
replace a portion of the hip joint; either the ball or the socket or both. One generally
used hip joint replacement technique involved removal of a head and neck of the
20 femur, and the insertion of a long angled and tapered metal prosthesis into the central
"intramedullary" canal at the open upper end of the main straight portion of the femur.
This femoral prosthesis typically had a relatively small metal ball at its upper end
which mated with a small plastic socket mounted on the hip side of the joint.
However, this "total" hip replacement technique was drastic, involving complete
25 removal of the head and neck of the femur, and made any subsequent hip joint
problems difficult to handle.

U.S. Patent No. 4,123,806 to Amstutz, et al., discloses an early femoral
prosthesis having a cobalt-chromium-molybdenum metallic shell of generally
hemispherical shape. This femoral prosthesis is designed on the principle of
30 removing all non-viable femoral head bone, but also preserving as much of the head
and neck as possible.

In a more recent development, U.S. Patent No. 6,156,069 to Amstutz ("the
'069 patent"), which is commonly assigned and hereby incorporated herein by

reference, discloses a metal-to-metal surface hip joint replacement. As shown in Figures 1-3 of the '069 patent, the metal-to-metal replacement includes a metallic (e.g. cobalt-chrome alloy) femoral prosthesis **22** and an acetabular prosthesis **40** also constructed of a metal material. Notably, Figure 1 of the '069 patent shows that placement of the femoral prosthesis requires shaping of the femoral head **30** to fit a stem **24** and internal geometry of the femoral prosthesis. Shaping of the femoral head requires the use of various cutting and drilling tools. Accurate completion of such shaping procedures is aided by the accurate placement of a Steinman pin or guide wire **74** which guides the cutting and drilling tools. The '069 patent discloses what has become commonly known as femoral head resurfacing.

A clamp **62** is used to facilitate centering and placement of the guide wire, as shown in Figure 9 of the '069 patent. The clamp includes a pair of jaws **64** that are supported by support member **68** and at pivot points **66** that allow pivotal rotation of the jaws with respect to the support member. Such rotation allows the jaws to engage the neck **32** of the femur **28**. The jaws are advanced and retracted by rotation of a handle **70** which advances a threaded actuator **76** through the body and moves a camming surface **72** attached thereto. The camming surface, in turn, drives opening and closure of the jaws about the neck. After the clamp is secured, the pin or guide wire is inserted into, and advanced through, collinear guide openings defined in the handle and threaded actuator until hitting an entry point **78** on the femoral head **30**. Advantageously, the ability of the clamp to engage and hold the guide openings in a fixed position relative to the femur promotes the accurate insertion of the guide wire or pin.

Despite the advantages of the clamp disclosed by the '069 patent, further improvements in the adjustability of positioning of pins and guide wires to improve the accurate placement of femoral prostheses are always desirable. It would be advantageous, therefore, to have a clamp and method with improved options to easily and accurately place a guide wire or pin which is subsequently used to guide femoral head resurfacing.

BRIEF SUMMARY OF THE INVENTION

The present invention addresses the above needs and achieves other advantages by providing a guide clamp for clamping a femur and guiding placement of a guide wire relative to the femur

5 It is an object of the invention to provide a guide clamp capable of one-handed operation.

It is an object of the invention to provide a guide clamp that provides for the more accurate centering of guide pins in, for example, the femoral head.

10 These and other objects of the invention are achieved by a guide clamp for clamping of a femur having a head and a neck, and guiding placement of a guide wire relative to the femur, the guide clamp comprising: at least two clamping surfaces configured to move between an open position and a closed position, wherein the clamping surfaces are sufficiently spaced apart in the open position to allow insertion of the femur therebetween and wherein the clamping surfaces generally oppose each other and are sufficiently close together in the closed position to firmly hold the femur therebetween; a body supporting the clamping surfaces and configured to allow movement of the clamping surfaces relative to each other, the body defining a guide opening configured to receive and allow passage of the guide wire therethrough to the femur; and a biasing assembly configured to bias the clamping surfaces into the closed position about the femur wherein the clamping surfaces secure the body relative to the femur so that the guide wire is secured relative to the femur when extending through the guide opening defined by the body.

15 20 25 30 These and other objects of the invention are achieved by a guide clamp for clamping of a femur and guiding placement of a guide wire relative to the femur, the guide clamp comprising: at least two clamping surfaces configured to move between an open position and a closed position, wherein the clamping surfaces are sufficiently spaced apart in the open position to allow insertion of the femur therebetween and wherein the clamping surfaces generally oppose each other and are sufficiently close together in the closed position to firmly hold the femur therebetween; a body supporting the clamping surfaces and configured to allow movement of the clamping surfaces relative to each other, the body defining a guide opening configured to receive and allow passage of the guide wire therethrough to the femur; and an engagement member supported by the body and which is configured to extend

therefrom into abutting contact with the head of the femur when the contact surfaces are in the closed position and the clamping surfaces secure the femur.

Furthermore, it is an object of the invention to provide a method of using the guide.

5

BRIEF DESCRIPTION OF THE SEVERAL VIEWS OF THE DRAWING(S)

Having thus described the invention in general terms, reference will now be made to the accompanying drawings, which are not necessarily drawn to scale, and wherein:

10 Figure 1 is a perspective view of a guide clamp of one embodiment of the present invention secured to a femur;

Figure 1A is a perspective view of a guide clamp of one embodiment of the present invention secured in a preferred orientation on a femur.

Figure 2 is a side elevation view of the guide clamp of Figure 1;

15 Figure 3 is a front elevation view of the guide clamp of Figure 1;

Figure 4 is a plan view of a body of the guide clamp of Figure 1;

Figure 5 is a side elevation view of a body of the guide clamp of Figure 1;

Figure 6 is another side elevation view of a body of the guide clamp of Figure 1;

20 Figure 7 is perspective view of a guide pin being used to guide resurfacing of a femoral head, said guide pin having been placed by the guide clamp of Figure 1;

Figure 8 is a side elevation view of a clamping arm of the guide clamp of Figure 1;

25 Figure 9 is a side elevation view of a proximal portion of another clamping arm of the guide clamp of Figure 1;

Figure 10 is a side elevation view of a distal portion of the clamping arm of the guide clamp of Figure 1;

Figure 11 is another side elevation view of the distal clamping arm portion of Figure 10;

30 Figure 12 is a plan view of the distal clamping arm portion of Figure 10;

Figure 13 is another side elevation view of the proximal portion of Figure 9;

Figure 14 is a cross-sectional view of the guide clamp of Figure 1;

Figure 15 is a side elevation view of a rack member of the guide clamp of Figure 1;

Figure 16 is a cross-sectional view of a knob retaining cap of the guide clamp of Figure 1;

5 Figure 17 is a cross-sectional view of a locking knob of the guide clamp of Figure 1;

Figure 18 is a side elevation view of a primary guide shaft of the guide clamp of Figure 1; and

10 Figure 19 is a side elevation view of a textured tip of the guide clamp of Figure 1.

DETAILED DESCRIPTION OF THE INVENTION

The present invention now will be described more fully hereinafter with reference to the accompanying drawings, in which some, but not all embodiments of the invention are shown. Indeed, this invention may be embodied in many different forms and should not be construed as limited to the embodiments set forth herein; rather, these embodiments are provided so that this disclosure will satisfy applicable legal requirements. Like numbers refer to like elements throughout.

20 A guide clamp **10** of one embodiment of the present invention includes a body **11** movably supporting two or more clamping surfaces **12** that can be moved from an open (separated) position that allows insertion of a femur **13** (and more specifically the femoral head **17**) therebetween and a closed position wherein the clamping surfaces are firmly secured about the femur (e.g., around a neck **16** of the femur), as shown in Figures 1-3. Defined in the body **11** is a guide opening **14** that allows passage of a primary guide shaft **59**. In turn, the primary guide shaft **59** defines a guide opening **64** that allows direct passage of a Steinmann pin or guide wire **15** directly therethrough to intersect a head **17** of the femur **13**. The term "guide opening" as used herein describes any opening that directly (e.g., guide opening **64**), or indirectly (e.g., guide opening **14** which houses the guide shaft **59** defining directly guiding opening **64**), supports the guide wire **15**.

30 When firmly secured about the femur, the guide clamp **10** preferably aligns guide openings **14**, **64** with the central axis of the femoral head **17** and the clamping surfaces grip the femur sufficiently tightly to allow steady guidance of the guide wire

as its extends to the femur 13. Generally, the guide clamp 10 can further include one or more alternative or combined aspects of the invention, such as: the use of a biasing assembly 18 (Fig. 14) and/or use of an engagement member 20.

Referring in particular to Figure 1, the femur of the patient is shown disassociated from the acetabular socket (not shown) and includes the femoral head 17 separated by the femoral neck 16 from the remaining portions of the femur 13. Generally, as is typical in most humans, the femoral head 17 has a semi-spherical shape that at its base is supported by the neck 16 which is roughly cylindrical with a narrowing diameter as it extends to its attachment to the rest of the femur 13.

Although the guide clamp 10 of the present invention is preferably used to place the guide wire 15 in the femoral head 17, the guide clamp could also be used to place the guide wire in other parts of the femur, or even other bones, such as the tibia or humerus, where the guide wire needs to be centered along the axis of a ball and socket joint.

Anatomical terminology is used herein, and in particular the terms "proximal" and "distal," are used herein to refer to guide clamp 10 as if it were attached to the femur 13 in the anatomical position with a top of the guide clamp (with respect to its orientation in Figure 1) being proximal and the bottom of the guide clamp extending distally to attach to the femoral neck 16. However, these directional references are used for clarity and convenience and it should be recognized that other orientations are also possible for the guide clamp 10 and still fall within the purview of the present invention.

The body 11 of the illustrated guide clamp 10 may be constructed of a unitary piece of material having a main portion 22, a pair of clevises 23 and a pair of finger grip mounts 26, as shown in Figures 4-6. The clevises 23 are spaced apart on opposite lateral sides of the main portion 22. Each of the clevises 23 includes a pair of clevis members 25 extending laterally from the lateral sides of the main portion 22.

The clevis members 25 of each pair are spaced from each other and define a clevis slot 27 therebetween. Each of the clevis members 25 defines a cylindrical opening 28. The cylindrical opening of each of the clevis members 25 is concentrically aligned with the cylindrical opening 28 of the adjacent one of the clevis members. This arrangement allows each adjacent pair of the cylindrical openings to receive one of a pair of arm shafts 42 so as to form a rotatable mount for supporting

one of a pair of clamping arms 19 which, as described below, serve as supports for the clamping surfaces 12.

The finger grip mounts 26 are positioned on the remaining opposite sides of the main portion 22 (that the clevis members 25 are not on) and extend outwards from the main portion, as shown in Figure 4. Each of the finger grip mounts 26 defines a threaded cylindrical opening 29 which is aligned with the threaded cylindrical opening defined by the other one of the finger grip mounts. The finger grip mounts 26 allow attachment of a pair of finger grips 30 on opposite sides of the main portion 22.

Defined by the main portion 22 are a plurality of openings, including the guide opening 14 (as shown in Figure 4), three view ports 32, a pair of restraining pin mounts 33 (as shown in Figure 5) and a pair of clamping arm guides 35 (as shown in Figure 6). Two of the view ports 32 are spaced on opposite sides of the finger grip mounts 26 and one of the view ports is positioned at the distal end of the main portion. The restraining pin mounts 33 are positioned adjacent the clevises 23 and are sized and shaped to receive restraining pins 34.

The guide opening 14, as shown best in Figure 4, has a cylindrical shape and extends in the proximal-distal direction from a proximal end of the body 11 to a distal end of the body. The diameter of the body guide opening 14 is the same for most of its length with the exception of a stepped drop to about half its major diameter immediately adjacent the distal end of the body 11 which is due to an inwardly directed retaining flange 57 of the body, as shown in Figure 14. The clamping arm guides 35 are elongated slots defined on opposite sides of the main portion 22 and are positioned between respective pairs of the clevis members 25 at the base of each clevis slot 27, as shown in Figure 6. The clamping arm guides 35 are in communication with the distal portion of the guide opening 14 so as to allow passage therethrough of proximal ends of the clamping arms 19.

The term "body" as used herein should be construed broadly to include any structure, or combination of structures, that provide movable support for at least one of the clamping surfaces 12 and defines one or more openings (e.g., opening 14) through which the guide wire 15 can be extended. Movably supporting the clamping surfaces 12 refers to allowing, or facilitating movement in one or more degrees-of-freedom of at least one of the clamping surfaces so that they can be positioned relative

to each other in the open and closed positions. For instance, the body could define track openings having cam shapes that allow combined translation and rotation of the clamping arms 19 for movement of the clamping surfaces 12 between the open and closed positions.

5 As another example, the body could define multiple guide openings 14, or differently shaped guide openings, and still fall within the purview of the present invention. Multiple guide openings could be used to directly or indirectly support multiple guide wires, or provide alternative position selections for the guide wires. Different sized and shaped guide openings can facilitate different sized and shaped
10 guide wires. The terms "guide wire" and "guide pin" or "pin" are used interchangeably herein to denote a generally elongate, rigid member used as a fixed reference point for e.g. resurfacing of the femoral head 17, as shown in Figure 7, or other portion of a patient's anatomy. Typically, that fixed reference point will be the central axis of the femoral head.

15 Each of the clamping arms 19 includes a first, proximal portion 38 and a second, distal portion 39, as shown in Figures 1-3. The proximal portion 38 includes a plurality of pinion teeth 40 and defines a rotation shaft opening 41 and a restraining pin slot 43 positioned between the pinion teeth and the rotation shaft opening, as shown in Figures 8 and 9. The rotation shaft opening 41 is sized and shaped to
20 receive a cylindrical arm shaft 42 which extends through the cylindrical opening 28 in each of a pair of adjacent clevis members 25 to rotatably support the clamping arm between the clevis members in the clevis slot 27, as shown in Figures 1-3.

 Each of the restraining pins 34 similarly extends through the aligned pair of restraining pin mounts 33 and the restraining pin slot 43 in the proximal portion 38 of
25 a respective one of the clamping arms 19. The restraining pin slot 43 allows sliding of the restraining pin therein while the clamping arm rotates about the arm shaft 42. However, the ends of the restraining pin slot 43 serve as end points for the rotation about the arm shaft 42.

 The distal portion 39 of each of the clamping arms 19 extends distally and
30 towards the distal portion of the other one of the clamping arms 19 when in the closed position, as shown in Figures 8 and 10. In particular, the distal portion 39 includes a distally directed first sub-portion 44 and second sub-portion 45 extending therefrom at a generally right angle thereto in the direction of the other one of the clamping arms

19. As shown in Figures 11 and 12, the second sub-portion 45 bifurcates into a pair of prongs 46 defining the respective one of the clamping surfaces 12 which abuts the femoral neck 16 in the closed position.

As shown in Figure 3, each of the clamping surfaces 12A, 12B are preferably sloped to form an oblique angle relative to the primary guide shaft 59, and more particularly to the axis of the guide opening 64 that passes through the primary guide shaft 59. The oblique angle is selected such that the clamping surfaces 12A, 12B orient the guide opening 64 slightly superior to the neutral axis of the femoral neck. This orientation causes the guide pin to enter the femoral head at a more vertical orientation than that of the natural neck. In turn, this allows the stem of a femoral head prosthesis to be implanted in a more vertical orientation, which distributes load more vertically and results in improved performance of the prosthesis. The axis of the femoral head prosthesis is preferably oriented about 5 degrees above the natural axis of the femoral neck. In order to achieve this orientation, the clamping surfaces 12A, 12B preferably have a slope of about five degrees relative to axis of the guide opening 64.

One of the clamping arms 19 has the optional feature of being adjustable independent of the coordinated movement of the pair of arms by the biasing assembly 18. In this embodiment, the adjustable one of the clamping arms 19 is separated into its proximal and distal portions, 38 and 39, respectively. The proximal portion has a widened distal sub-portion that defines an elongate opening 47 having a cylindrical shape that is open at the end opposite the pinion teeth 40, as shown in Figure 13. Defined in the widened distal sub-portion is an elongate slot 48 that extends a majority of the length of the elongate opening 47 and is in communication therewith.

The first sub-portion 44 of the distal portion 39 of the adjustable one of the clamping arms 19 has its own widened cross-section and a cylindrical shape configured to be slidably mounted within the elongate opening 47 of the proximal portion 38, as shown in Figure 2. The first sub-portion 44 also includes a pair of rounded, retaining protuberances 49 extending from opposite sides of the widened first sub-portion 44. These protuberances 49 extend between the walls of the proximal portion 38 within the elongate opening 47, so as to steady the distal portion 39 within the proximal portion 38, but still allow sliding motion therebetween. Optionally, the protuberances 49 may be outwardly biased (e.g., "ball and spring")

members), but capable of being pressed against their bias into openings defined in the first sub-portion 44 under pressure. Use of ball and spring type members obviates the need to closely tolerance the size of the elongate opening 47 and the first portion 44.

5 Relative sliding of the proximal and distal portions, 38 and 39, of the adjustable one of the clamping arms 19 is restrained using a pin 50 that is sized to be slidably retained in the elongate slot 48 defined by the proximal portion 38. In this manner, the range of sliding of the two portions 38, 39 is restrained and the two portions do not disassociate from each other at the end of their sliding range.

10 Advantageously, the sliding adjustability of the portions of the adjustable one of the clamping arms 19 allows the angle of the clamping surfaces 12 to be changed relative to each other. Changing of the relative angle of the clamping surfaces changes the orientation of the guide opening 14, and hence the orientation of the guide opening 64, with respect to the femur 13 which aids the surgeon in optimizing positioning of the femoral head prosthesis. It should be noted that adjustability may be achieved using other configurations. For instance, a rotatable hinge member could be employed between the two portions 38, 39, or some type of multi-bar linkage. However, the illustrated embodiment has the advantage of an easily controlled adjustability due to the limitation of motion in a single sliding direction having fixed endpoints.

20 The biasing assembly 18 of the present invention provides biasing force to the clamping arms 19 so as to urge the clamping surfaces 12 together into the closed position abutting the femoral neck 16. The biasing assembly 18 may also coordinate movement of the two clamping arms 19 so that they move between the open and closed positions simultaneously via one-handed operation.

25 In the illustrated embodiment, the biasing assembly is partially housed within the guide opening 14 of the body 11 and includes a rack member 51 and a coil spring 52, as shown in Figure 14. The rack member 51 includes a threaded portion 53 that extends out of the body 11 and a portion bearing a plurality of rack teeth ("toothed portion") 54 that extends within the guide opening 14 of the body 11, as shown in Figure 15. In addition, the rack member 51 defines its own guide opening 56 extending its entire axial length for allowing passage of the engagement member 20. The toothed portion is flanked by an opposing pair of flanges 55 and the teeth thereon extend outwards from a central axis of the rack member 51 and are adjacently

positioned to extend between the pair of flanges. The threaded portion **53** extends from a side of one of the flanges **55** opposite the toothed portion **54** and includes threads extending around the outside of a cylindrical shaft.

When positioned within the guide opening **14** of the body **11**, the coil spring **52** is positioned between the retaining flange **57** of the body **11** which narrows the body guide opening **14** and the distal one of the flanges **55** of the rack member **51**. The rack member **51** is positioned adjacent the coil spring **52** at its distal end, a portion of which extends into the coil spring, and adjacent a retaining cap **58** at its opposite end, as shown in Figure 14.

Positioning of the coil spring **52** at the distal end of the rack member **51** causes it to exert an upward bias onto the distal one of the flanges **55**. This upward bias causes the toothed portion **54** to move upwards against the pinion teeth **40** of both of the clamping arms **19** which extend through the clamping arm guides **35** to mesh with the toothed portion. In turn, this upward bias causes coordinated movement distally and inwardly (due to rotation about the arm shaft **42**) toward the femoral neck **16** of the clamping surfaces **12** at the opposite ends of the clamping arms **19** from the pinion teeth.

The retaining cap **58** is affixed to the body **11** and extends within the proximal end of the guide opening **14** of the body **11** to abut the proximal one of the flanges **55** of the rack member **51** when the clamping arms **19** are in the closed position, as shown in Figure 1. In addition, the retaining cap **58** defines a central opening that is in communication with the guide opening **14** of the body **11** when secured to the body allowing passage therethrough of the engagement member **20**.

Together, the retaining flange **57** and the retaining cap **58** hold the biasing assembly **18** within the guide opening **14** of the body **11** and provide a limit for the movement of the rack member **51**, which in turn limits motion of the clamping arms **19**. Further limitation of the motion of the biasing assembly **18** is achieved by tightening the finger grips **30** in the threaded openings **29** of the finger grip mounts **29** so that the ends of the finger grips abut the sides of the rack member **51**. This also allows the user of the guide clamp **10** to lock the clamping arms **19** in place once the femoral neck **16** has been gripped by the clamping surfaces **12**.

Additional limitation in the movement of the biasing assembly **18** can be achieved through use of a locking knob **61** that includes a central, threaded opening

62, as shown in Figures 14 and 17. The central, threaded opening of the locking knob 61 allows it to be advanced along the threaded portion 53 of the rack member 51 until it abuts the retaining cap 58 positioned on the body 11. If the proximal one of the flanges 55 on the rack member 51 is abutting the opposite side of the retaining cap 58, the position of the locking knob 61 will lock biasing assembly 18 into its abutting position against the retaining cap, thereby locking the clamping arms 19 and clamping surfaces 12 into the closed position.

Alternatively, advancement of the locking knob 61 short of co-abutment of the retaining cap 58 with the proximal one of the flanges 55 further reduces the range of motion of the rack member 51 in the distal direction. This effectively limits the proximal and outwards range of motion of the clamping arms 19 and the space between the clamping surfaces 12 when in the open position. Proximal movement of the locking knob 61 along the threaded portion 53 of the rack member 51 is restrained using a knob retaining cap 63, as shown in Figures 14 and 16. The knob retaining cap has a threaded opening to allow it to be secured on the most proximal end of the threaded portion 53 of the rack member 51.

It should be noted that the biasing assembly 18 can include various different components as long as it biases the clamping surfaces 12 into the closed position about the femoral neck 16 and preferably also coordinates movement of the clamping surfaces. For instance, the biasing assembly could include leaf or coil springs incorporated in the clamping arms 19 to urge the clamping surfaces together 12. Notably, in such a configuration the biasing assembly is not necessarily contained within the body 11 of the guide clamp 10. However, the biasing assembly 18 of the illustrated embodiment being at least partially contained within the guide opening 14 of the body 11 has the advantages of limiting movement as described above.

In another aspect, the guide clamp 10 of the present invention may include the engagement member 20. The engagement member includes the primary guide shaft 59 and a textured tip 60. As shown in Figure 18, the primary guide shaft 59 of the illustrated embodiment is an elongate, cylindrical shaft defining the guide opening 64 extending its entire length. Unlike the previously described guide openings, the guide opening 64 of the primary guide shaft 59 is in direct contact with the guide wire 15 as it extends through the guide clamp 10. The primary guide shaft 59 includes a

retaining ring **65** fixed to its proximal end and a threaded portion **66** at its distal end having a reduced diameter.

The textured tip **60** of the illustrated embodiment also has a cylindrical shape and the distal end of the textured tip **60** has a plurality of serrations that provide a textured gripping surface for abutting the femoral head **17**, as shown in Figure 1. In addition, the textured tip **60** defines a threaded opening **67** (as shown in Figure 19) that is sized to mate with the threaded portion **66** at the distal end of the primary guide shaft **59**, allowing the textured tip to be secured thereto. The term "textured" as used herein denotes any type of surface or pattern that facilitates a non-slip abutment with the femoral head **17**, such as crenellations, cross-hatching or the illustrated serrations. Non-slip abutment with the femoral head is preferable so as to assure a proper and more accurate path for the guide wire along the selected reference line/point.

Threaded attachment facilitates assembly of the guide clamp **10** by allowing the primary guide shaft **64** to be inserted through the opening of the retaining cap **58**, the guide opening **56** of the rack member **51**, the coil spring **52** and the opening in the retaining flange **57** of the body **11** until its distal end extends out of the body. The threaded opening **67** of the textured tip **60** is then secured on the threaded portion **66** of the primary guide shaft **59**.

The various openings through which the primary guide shaft **59** extends are sized to allow sliding of the engagement member **20** so that it can be advanced and retracted from abutting contact with the femoral head **17**. Advancement and retraction is limited by the retaining ring **65** at the proximal end of the engagement member **20** and the textured tip **60** at the distal end of the engagement member. While it is possible to provide a means for locking the engagement member adjacent the femoral head, such will typically not be necessary. The friction forces between the engagement member and the guide shaft and the non-slip abutment are typically enough to prevent unwanted movement of the engagement member.

It should be noted that the engagement member **20** of the present invention need not be limited to the illustrated embodiment and can include any member, or combination of members (such as an arm that swings distally to contact the femoral head **17**), that are capable of providing a moveable third surface for engagement with the femur **13** in addition the to clamping surfaces **12**. Preferably, the engagement

member 20 also further provides an extended guide opening that is capable of guiding insertion of the guide wire 15 right up to the surface of the femoral head 17.

Having described the structure of guide clamp 10, we will now describe its use.

5 During use, the user grasps body 11 in between, e.g., the user's first and middle finger, with the first and middle finger gripping finger grips 26 and locking knob 61 of the guide clamp 10 to be manipulated by the thumb of the same hand. The locking knob 61 is then pushed into the body 11 by the thumb, which moves the rack member 51 against the bias of the coil spring 52. The teeth of the toothed portion 54
10 cause the pinion teeth 40 at the proximal portion 38 of the clamping arms 19 to rotate distally about the arm shafts 42, causing the distal portion 39 of the clamping arms, and the clamping surfaces 12 supported thereby, to move proximally and outwardly away from each other into an open position. At this point, the femur 13, and in particular the femoral neck 16, is inserted in between the pair of clamping surfaces 12.

15 Once the femoral neck 16 has been positioned the locking knob 61 is released allowing the toothed portion 54 to be urged proximally by the coil spring 52. Such urging causes the toothed portion 54 and pinion teeth 40 to interact and rotate the proximal portion 38 of each of the clamping arms 19 proximally about the arm shafts 42. In turn, the distal portion 39 of the clamping arms 19, and the clamping surfaces
20 12 supported thereby, rotate about the arm shafts 42 distally and towards each other to close about the femoral neck 16. Once in the closed position, the locking knob 61 can be advanced on the threaded portion 53 until it abuts the retaining cap 58 and holds the proximal one of the flanges 55 against the other side of the retaining cap. This effectively locks the guiding clamp 10 into position on the femur 13. Thus, what was
25 originally a two-handed operation has now been reduced to a one-handed operation.

 Adjustments to the angle of the guide opening 64 of the primary guide shaft 59 with respect to the femoral head 17 can be made by adjusting the adjustable one of the clamping arms 19. For instance, the distal portion 39 of the clamping arm can be slid within the elongate opening 47 defined by the proximal portion 38 until a desired
30 change in angle is achieved.

 Once the clamping surfaces 12 have been secured in the closed position, the primary guide shaft 59 of the engagement member 20 is advanced within the guide opening 56 of the rack member 51, and other openings, until the textured tip 60 abuts

the femoral head 17. In this manner, the guide opening 64 of the primary guide shaft 59 extends right up to the surface of the femoral head 17. The guide wire 15 is then inserted into guide opening 64 defined at the retaining ring 65 of the engagement member, and is advanced through the rest of the guide opening 64 of the primary
5 guide shaft 59 until it intersects the femoral head 17. The guide wire 15 is then driven into the femoral head 17 using a hammer, drill or other device known in the art.

Once the pin has been secured, the guide clamp 10 is removed by loosening the locking knob 61 and repeating the steps described above for moving the clamping surfaces 12 to the open position. After removal of the guide clamp 10, the guide wire
10 15 is used as a guide for cutting the femoral head 17 using a cannulated drill and bit, as shown in Figure 7.

The present invention has many advantages. For example, coordinated, biased closing movement of the clamping surfaces 12 using the biasing assembly 18
15 allowing for one-handed operation. Such coordinated, biased closing movement ensures that the clamping arms 19 and their clamping surfaces 12 center the femoral neck 16 between them for proper alignment of the various guide openings with the femoral head 17. The adjustability of one, or more, of the clamping arms 19 allows for modifications of the angle at which the various guide openings, and hence the angle of the guide wire 15, will be positioned with respect to the femoral head 17.
20 The engagement member 20 bridges the gap between the body 11 of the guiding clamp 10 and the femoral head 17 by providing additional guide opening length up to the femoral head. This improves the accuracy of placement of the guide wire 15. In addition, the textured tip 60 of the engagement member increases the security of the grip that the guiding clamp 10 has on the femur 13.

25 Many modifications and other embodiments of the inventions set forth herein will come to mind to one skilled in the art to which these inventions pertain having the benefit of the teachings presented in the foregoing descriptions and the associated drawings. Therefore, it is to be understood that the inventions are not to be limited to the specific embodiments disclosed and that modifications and other embodiments are
30 intended to be included within the scope of the appended claims. Although specific terms are employed herein, they are used in a generic and descriptive sense only and not for purposes of limitation.

CLAIMS

What is claimed is:

1. A guide clamp for clamping of a femur having a head and a neck, and
5 guiding placement of a guide wire relative to the femur, said guide clamp comprising:
at least two clamping surfaces configured to move between an open
position and a closed position, wherein said clamping surfaces are sufficiently spaced
apart in the open position to allow insertion of the femur therebetween and wherein
said clamping surfaces generally oppose each other and are sufficiently close together
10 in the closed position to firmly hold the femur therebetween;
a body supporting the clamping surfaces and configured to allow
movement of the clamping surfaces relative to each other, said body defining a guide
opening configured to receive and allow passage of the guide wire therethrough to the
femur; and
15 a spring biasing assembly configured to bias the clamping surfaces into
the closed position about the femur wherein the clamping surfaces secure the body
relative to the femur so that the guide wire is secured relative to the femur when
extending through the guide opening defined by the body.
- 20 2. A guide clamp of Claim 1, further comprising a pair of clamping arms,
wherein each of said clamping arms includes one of the clamping surfaces.
3. A guide clamp of Claim 2, wherein the spring biasing assembly is
configured to bias both of the clamping arms and coordinate movement of the
25 clamping surfaces between the open and closed positions.
4. A guide clamp of Claim 2, wherein both of the clamping arms are
rotatably supported by the body and wherein the spring biasing assembly is operably
engaged with both of the clamping arms so as to bias the clamping arms into the
30 closed position.
5. A guide clamp of Claim 4, wherein each of the clamping arms includes
a plurality of pinion teeth and wherein the spring biasing assembly includes a biased

rack with a plurality of rack teeth configured to engage the pinion teeth of the clamping arms so that movement of the rack causes rotation of the clamping arms and relative movement of the clamping surfaces.

5 6. A guide clamp of Claim 5, wherein the biasing assembly includes a coil spring extending around the biased rack and biasing the rack to move the clamping surfaces of the clamping arms into the closed position.

10 7. A guide clamp of Claim 4, wherein the spring biasing assembly includes a translation member and spring, wherein said translation member is configured for linear translation with respect to the body and includes engagement elements configured to engage each of the clamping arms and wherein said spring is configured to linearly bias the translation member with respect to the body.

15 8. A guide clamp of Claim 7, wherein the spring is a coil spring including a first end abutting the body and a second end abutting the translation member.

20 9. A guide clamp of Claim 8, wherein the coil spring extends about the translation member and wherein the translation member defines a guide opening extending within the guide opening of the body.

 10. A guide clamp of Claim 2, wherein the clamping surface of one of the clamping arms is configured for adjustable positioning.

25 11. A guide clamp of Claim 1, further comprising an engagement member supported by the body and extending therefrom into abutting contact with the head of the femur when secured between the clamping surfaces.

30 12. A guide clamp of Claim 11, wherein the engagement member defines a guide opening aligned with the guide opening defined in the body and allowing passage of the guide wire through both of the guide openings to the head of the femur.

13. A guide clamp of Claim 12, wherein the engagement member is movably supported by the body allowing the engagement member to be retracted from, and extended into, abutting contact with the head of the femur.

5 14. A guide clamp of Claim 13, wherein the engagement member is slidably supported by the body along the axis of the guide opening defined by the body allowing the engagement member to be retracted from, and extended into, abutting contact with the head of the femur.

10 15. A guide clamp of Claim 14, wherein the engagement member includes a textured femur-adjacent end.

16. A guide clamp of Claim 15, wherein the textured femur-adjacent end includes serrations.

15

17. A guide clamp for clamping of a femur and guiding placement of a guide wire relative to the femur, said guide clamp comprising:

at least two clamping surfaces configured to move between an open position and a closed position, wherein said clamping surfaces are sufficiently spaced apart in the open position to allow insertion of the femur therebetween and wherein said clamping surfaces generally oppose each other and are sufficiently close together in the closed position to firmly hold the femur therebetween;

20

a body supporting the clamping surfaces and configured to allow movement of the clamping surfaces relative to each other, said body defining a guide opening configured to receive and allow passage of the guide wire therethrough to the femur; and

25

an engagement member supported by the body and which is configured to extend therefrom into abutting contact with the head of the femur when the contact surfaces are in the closed position and the clamping surfaces secure the femur.

30

18. A guide clamp of Claim 17, wherein the engagement member defines a guide opening aligned with the guide opening defined in the body and allowing passage of the guide wire through both of the guide openings to the head of the femur.

19. A guide clamp of Claim 18, wherein the engagement member is movably supported by the body allowing the engagement member to be retracted from, and extended into, abutting contact with the head of the femur.

5

20. A guide clamp of Claim 18, wherein the engagement member is slidably supported by the body, allowing the engagement member to be retracted from, and extended into, abutting contact with the head of the femur.

10

21. A guide clamp of Claim 20, wherein the engagement member includes a textured femur-adjacent end.

22. A guide clamp of Claim 21, wherein the textured femur-adjacent end includes serrations.

15

23. A guide clamp of Claim 20, further comprising a pair of clamping arms, wherein each of said clamping arms includes one of the clamping surfaces.

20

24. A guide clamp of Claim 23, wherein the clamping surfaces are configured to extend around the neck of the femur when adjacent to each other in the closed position.

25. A method of clamping a femur to facilitate insertion of a guide wire into the femur, said method comprising:

25

separating at least two opposing clamping surfaces of a guide clamp against a spring bias by moving the clamping surfaces relative to a body that supports the opposing clamping surfaces;

inserting a femur between the clamping surfaces;

closing the pair of opposing clamping surfaces onto the femur by

30

allowing the clamping surfaces to move with the spring bias relative to the body so as to secure the femur between the clamping surfaces; and

inserting a guide wire through a guide wire opening defined by the body and advancing the guide wire into contact with the femur, wherein the guide wire is supported by the body and clamping surfaces relative to the femur.

5 26. A method of clamping of Claim 25, further comprising advancing an engagement member supported by the body into abutting contact with a head of the femur after closing the clamping surfaces.

10 27. A method of clamping of Claim 26, wherein inserting the guide wire includes advancing the guide wire through a guide wire opening defined in the engagement member, wherein said guide wire openings of the body and engagement member are generally aligned.

FIGURE 1A

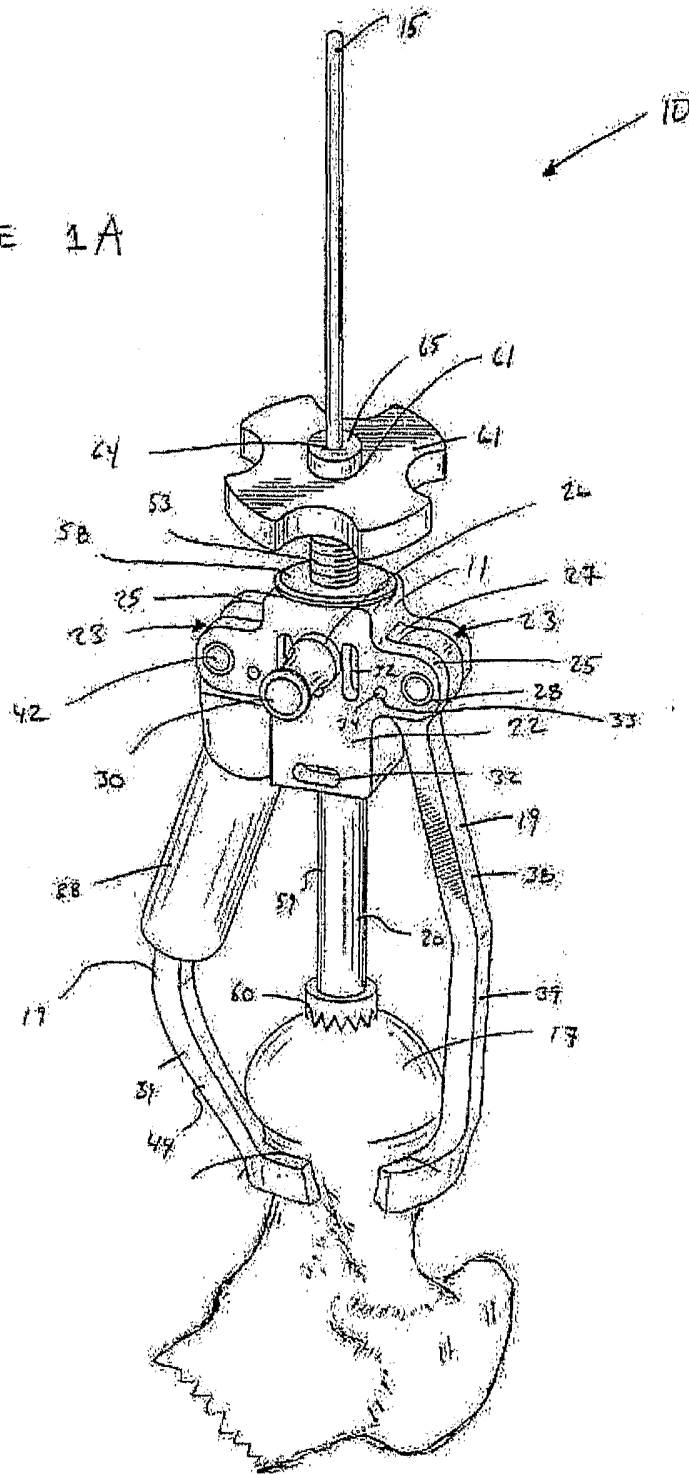

FIGURE 2

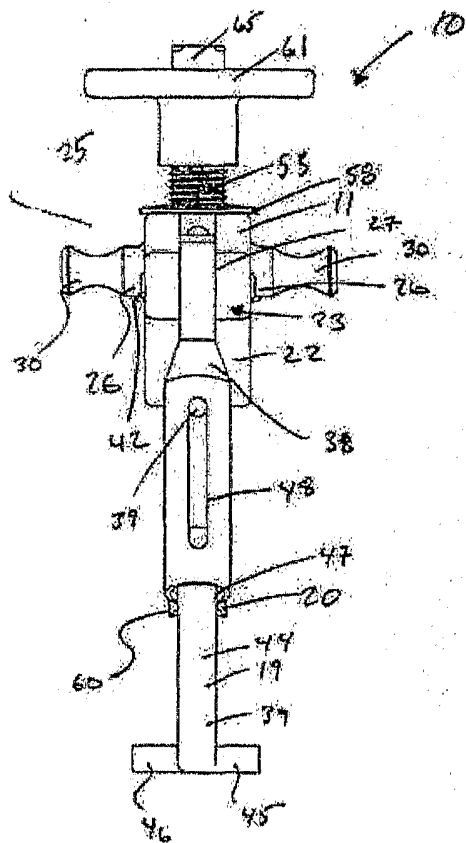

FIGURE 3

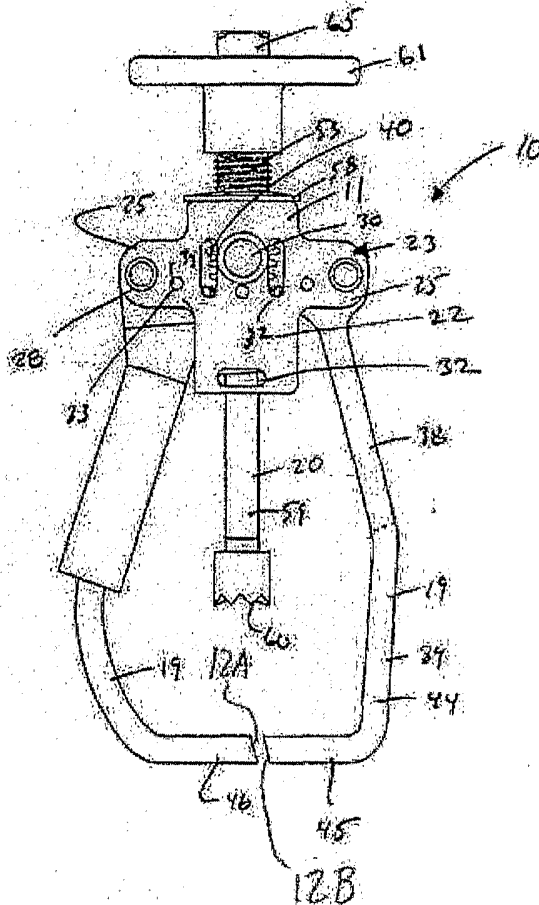

FIGURE 4

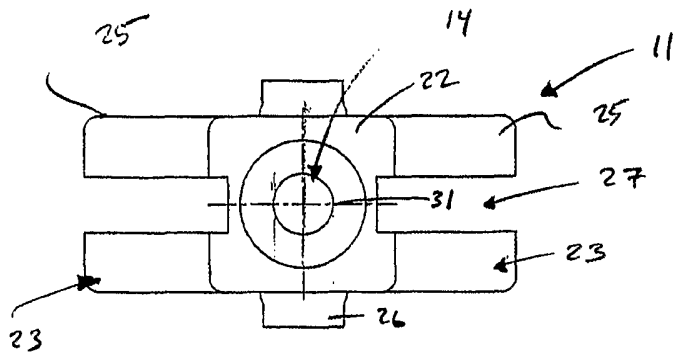

FIGURE 5

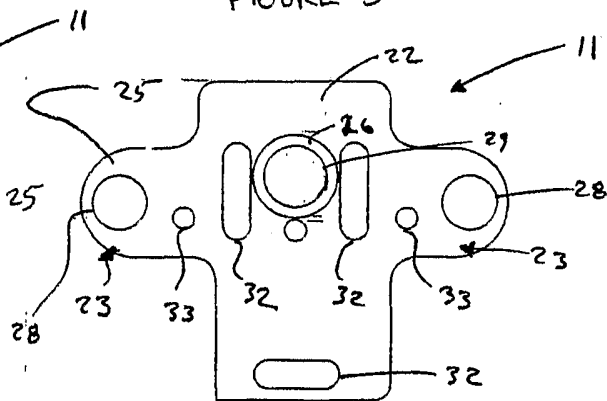
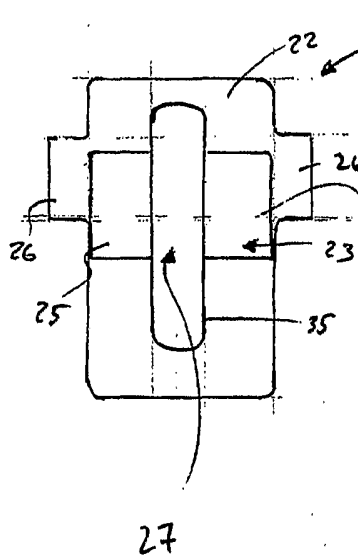

FIGURE 6



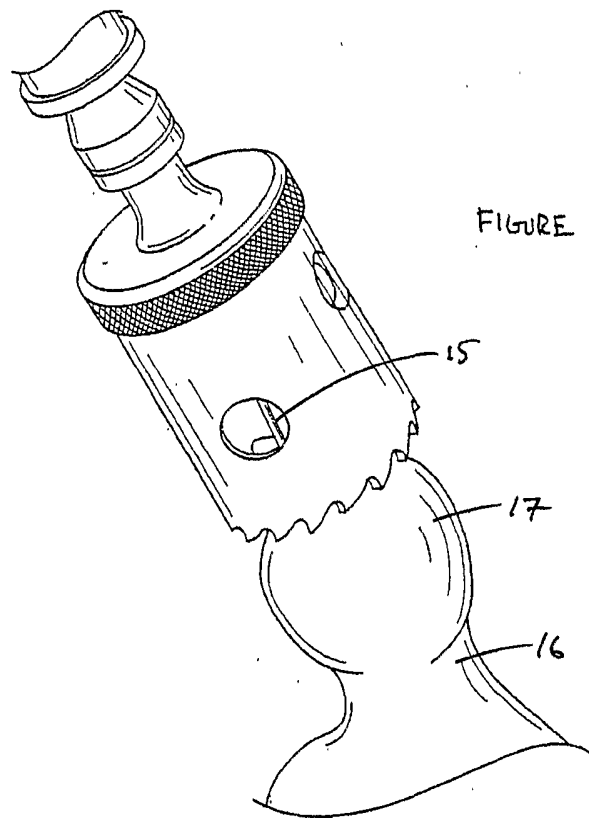

FIGURE 7

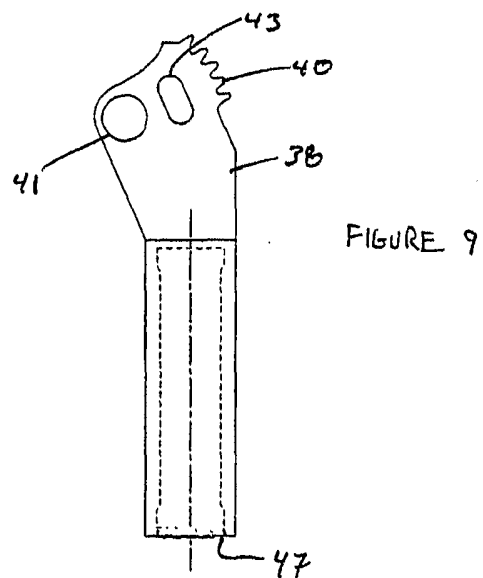
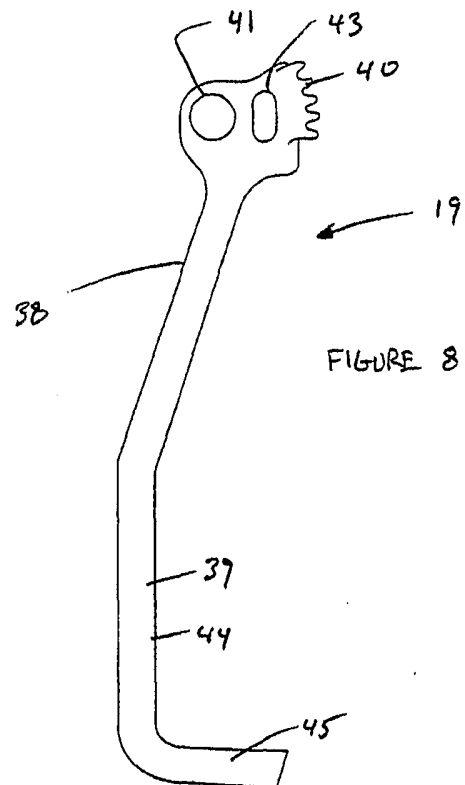

FIGURE 10

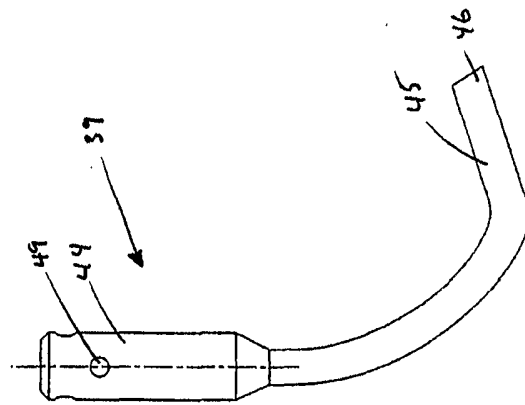

FIGURE 11

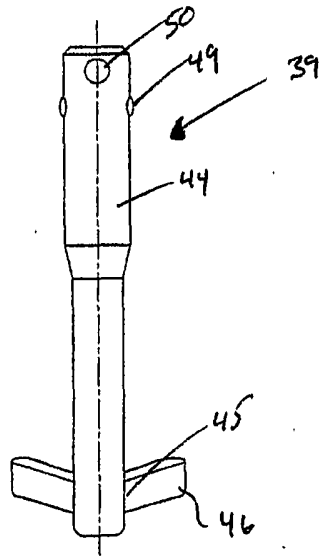

FIGURE 12

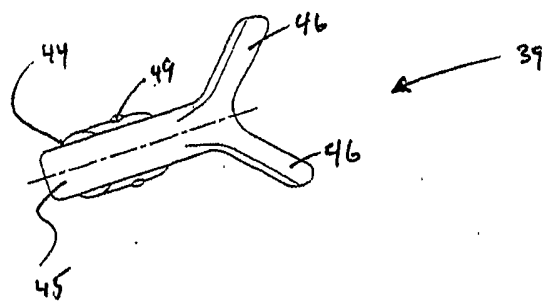

FIGURE 13

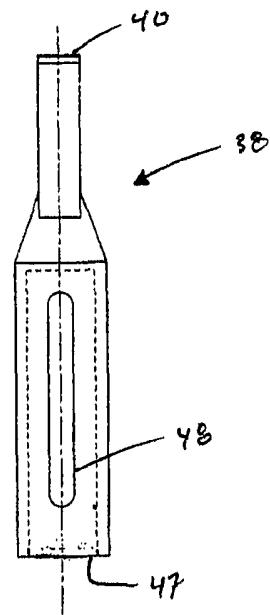
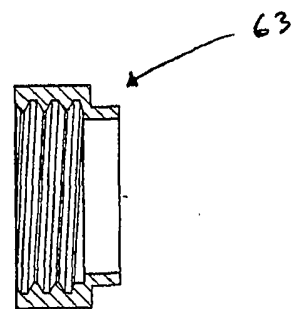
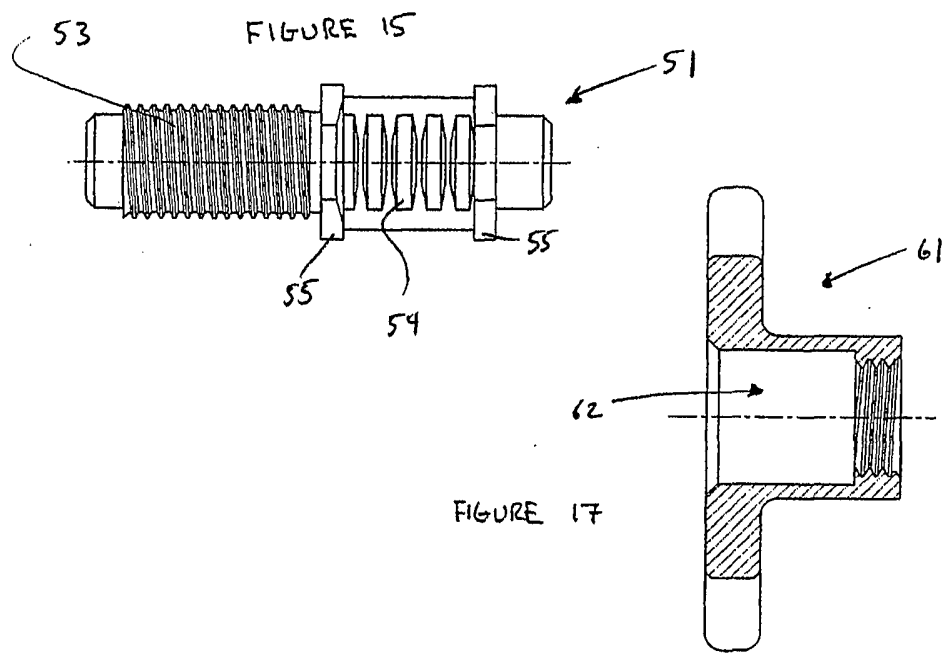

FIGURE 16





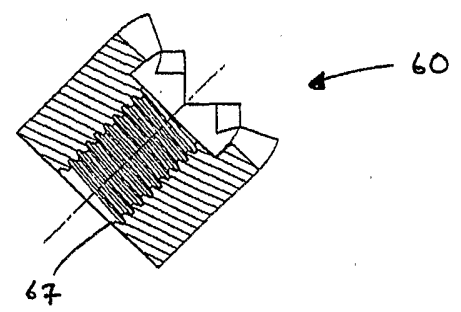
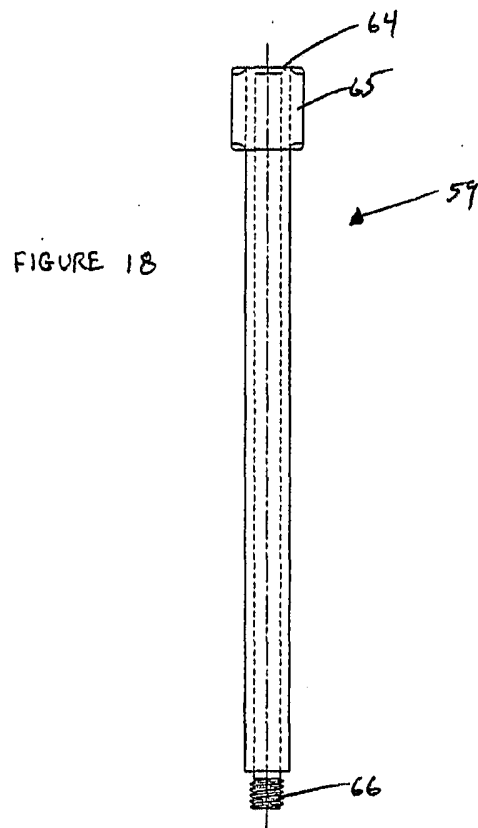

FIGURE 19

INTERNATIONAL SEARCH REPORT

International Application No
PCT/US2004/038931

A. CLASSIFICATION OF SUBJECT MATTER
IPC 7 A61B17/17

According to International Patent Classification (IPC) or to both national classification and IPC

B. FIELDS SEARCHED

Minimum documentation searched (classification system followed by classification symbols)
IPC 7 A61B

Documentation searched other than minimum documentation to the extent that such documents are included in the fields searched

Electronic data base consulted during the international search (name of data base and, where practical, search terms used)

EPO-Internal, PAJ

C. DOCUMENTS CONSIDERED TO BE RELEVANT

Category °	Citation of document, with indication, where appropriate, of the relevant passages	Relevant to claim No.
X	US 4 896 663 A (VANDEWALLS ET AL) 30 January 1990 (1990-01-30)	17-24
Y	column 2, line 45 - column 4, line 66 figures	1-8, 11-16
Y	----- DE 100 13 331 A1 (BIOMET MERCK DEUTSCHLAND GMBH) 20 September 2001 (2001-09-20)	1-8, 11-16
A	column 4, line 9 - column 6, line 43 figures	17-24
X	----- US 5 817 098 A (ALBREKTSSON ET AL) 6 October 1998 (1998-10-06)	17-24
A	column 5, line 23 - column 6, line 67 figures 2-4	1-16
	----- -/--	

Further documents are listed in the continuation of box C.

Patent family members are listed in annex.

° Special categories of cited documents :

- *A* document defining the general state of the art which is not considered to be of particular relevance
- *E* earlier document but published on or after the international filing date
- *L* document which may throw doubts on priority claim(s) or which is cited to establish the publication date of another citation or other special reason (as specified)
- *O* document referring to an oral disclosure, use, exhibition or other means
- *P* document published prior to the international filing date but later than the priority date claimed

- *T* later document published after the international filing date or priority date and not in conflict with the application but cited to understand the principle or theory underlying the invention
- *X* document of particular relevance; the claimed invention cannot be considered novel or cannot be considered to involve an inventive step when the document is taken alone
- *Y* document of particular relevance; the claimed invention cannot be considered to involve an inventive step when the document is combined with one or more other such documents, such combination being obvious to a person skilled in the art.
- *Z* document member of the same patent family

Date of the actual completion of the international search

14 March 2005

Date of mailing of the international search report

23/03/2005

Name and mailing address of the ISA

European Patent Office, P.B. 5818 Patentlaan 2
NL - 2280 HV Rijswijk
Tel. (+31-70) 340-2040, Tx. 31 651 epo nl,
Fax: (+31-70) 340-3016

Authorized officer

Nistor, L

INTERNATIONAL SEARCH REPORT

International Application No

PCT/US2004/038931

C.(Continuation) DOCUMENTS CONSIDERED TO BE RELEVANT

Category °	Citation of document, with indication, where appropriate, of the relevant passages	Relevant to claim No.
A	US 6 156 069 A (AMSTUTZ ET AL) 5 December 2000 (2000-12-05) cited in the application column 5, line 45 - line 56 figure 9	1-24
A	US 86 016 A (HOWEL SILAS J.) 19 January 1869 (1869-01-19) the whole document	1-16
A	US 2 416 228 A (SHEPPARD NELSON H) 18 February 1947 (1947-02-18) column 3, line 3 - column 5, line 19 figures	1-16
A	US 1 727 061 A (HICKS ROBERT J. F) 3 September 1929 (1929-09-03) page 1, line 71 - page 2, line 127 figures 1,2,4,5	1-16
A	DE 11 64 019 B (CHIRON-WERKE G.M.B.H) 27 February 1964 (1964-02-27) column 4, line 38 - column 5, line 3 figure 7	17-24
A	PATENT ABSTRACTS OF JAPAN vol. 1997, no. 07, 31 July 1997 (1997-07-31) & JP 09 075366 A (M II SYST:KK), 25 March 1997 (1997-03-25) abstract; figures 3,8	1,15-17, 21,22

INTERNATIONAL SEARCH REPORT

International application No.
PCT/US2004/038931

Box II Observations where certain claims were found unsearchable (Continuation of item 2 of first sheet)

This International Search Report has not been established in respect of certain claims under Article 17(2)(a) for the following reasons:

1. Claims Nos.: 25-27
because they relate to subject matter not required to be searched by this Authority, namely:
Rule 39.1(iv) PCT - Method for treatment of the human or animal body by surgery
2. Claims Nos.:
because they relate to parts of the International Application that do not comply with the prescribed requirements to such an extent that no meaningful International Search can be carried out, specifically:
3. Claims Nos.:
because they are dependent claims and are not drafted in accordance with the second and third sentences of Rule 6.4(a).

Box III Observations where unity of invention is lacking (Continuation of item 3 of first sheet)

This International Searching Authority found multiple inventions in this international application, as follows:

see additional sheet

1. As all required additional search fees were timely paid by the applicant, this International Search Report covers all searchable claims.
2. As all searchable claims could be searched without effort justifying an additional fee, this Authority did not invite payment of any additional fee.
3. As only some of the required additional search fees were timely paid by the applicant, this International Search Report covers only those claims for which fees were paid, specifically claims Nos.:
4. No required additional search fees were timely paid by the applicant. Consequently, this International Search Report is restricted to the invention first mentioned in the claims; it is covered by claims Nos.:

Remark on Protest

- The additional search fees were accompanied by the applicant's protest.
- No protest accompanied the payment of additional search fees.

FURTHER INFORMATION CONTINUED FROM PCT/ISA/ 210

This International Searching Authority found multiple (groups of) inventions in this international application, as follows:

1. claims: 1-16

guide clamp comprising at least two clamping surfaces, a body and a spring biasing assembly..

2. claims: 17-24

guide clamp comprising at least two clamping surfaces, a body and an engagement member.

INTERNATIONAL SEARCH REPORT

International Application No
PCT/US2004/038931

Patent document cited in search report	Publication date	Patent family member(s)	Publication date
US 4896663	A	30-01-1990	NONE
DE 10013331	A1	20-09-2001	NONE
US 5817098	A	06-10-1998	AT 257672 T 15-01-2004 AU 693697 B2 02-07-1998 AU 5783196 A 29-11-1996 BR 9608821 A 15-06-1999 CA 2219116 A1 21-11-1996 CN 1184410 A , C 10-06-1998 CZ 9703623 A3 17-06-1998 DE 69631344 D1 19-02-2004 DE 69631344 T2 02-12-2004 DK 957782 T3 17-05-2004 EP 0957782 A1 24-11-1999 ES 2213773 T3 01-09-2004 HU 9900303 A2 28-05-1999 JP 3307399 B2 24-07-2002 JP 11500045 T 06-01-1999 KR 267823 B1 01-11-2000 NO 975173 A 11-11-1997 NZ 308248 A 27-05-1998 PL 323351 A1 30-03-1998 PT 957782 T 31-05-2004 RU 2157665 C2 20-10-2000 WO 9636285 A1 21-11-1996 TR 9701374 T1 21-02-1998
US 6156069	A	05-12-2000	NONE
US 86016	A		NONE
US 2416228	A	18-02-1947	NONE
US 1727061	A	03-09-1929	NONE
DE 1164019	B	27-02-1964	NONE
JP 09075366	A	25-03-1997	NONE