

T. Coates,

Chill Bosh for Puddling Furnace.

No. 103983.

Patented June 7, 1870.

FIG. 1.

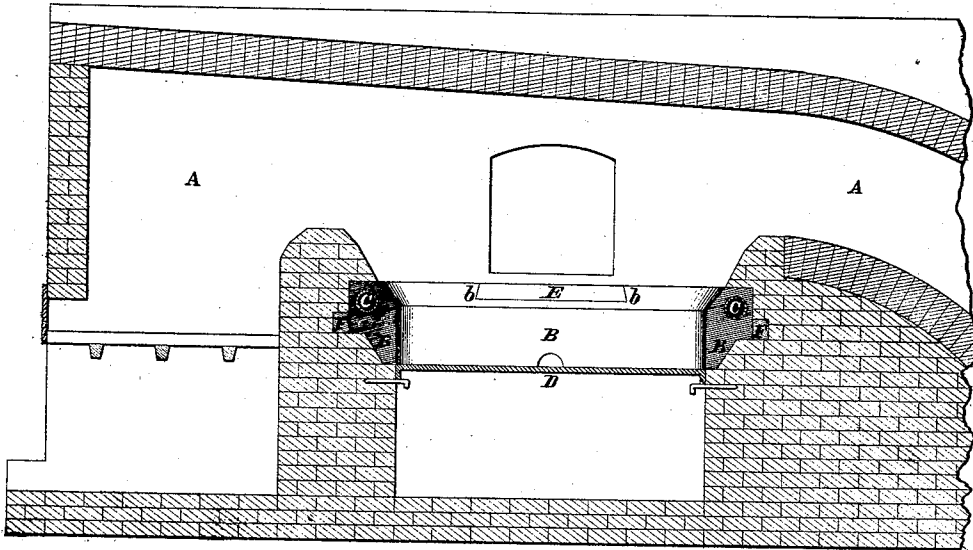

FIG. 2.

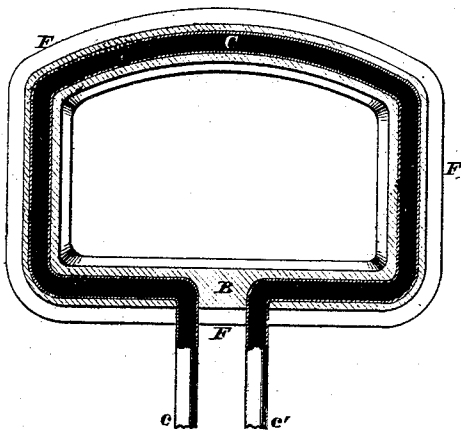
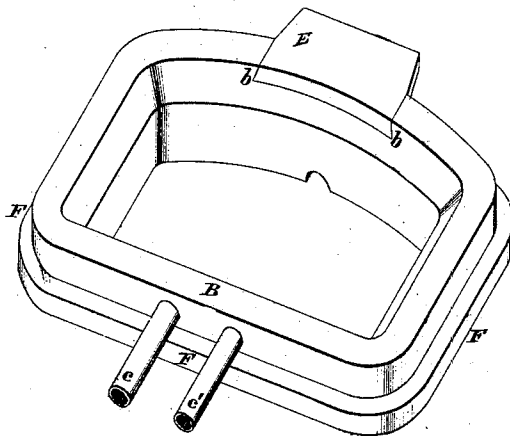

FIG. 3.



ATTEST.

Wm. H. Layman.
Notary Public

T. Coates
By his Atty. Knight Bros.

UNITED STATES PATENT OFFICE.

THOMAS COATES, OF IRONTON, OHIO.

IMPROVEMENT IN CHILL-BOSHES FOR BOILING AND PUDDLING FURNACES.

Specification forming part of Letters Patent No. **103,983**, dated June 7, 1870.

To all whom it may concern:

Be it known that I, THOMAS COATES, of Ironton, in the county of Lawrence and State of Ohio, have invented certain Improvements in Chill-Boshes for Boiling-Furnaces, of which the following is a specification.

My invention consists in casting the bosh or chill in one unbroken ring around a pipe for the conduction of water, and re-enforcing the same with a wrought-iron band, as hereinafter described.

Figure 1 is a longitudinal section of a reverberatory "boiling" furnace embodying my invention. Fig. 2 is a horizontal section of the chill. Fig. 3 is a perspective view of the chill.

A represents a portion of a customary iron puddling or boiling furnace for the conversion of "pig" into wrought iron.

My improved confining bosh or chill consists of a heavy piece of iron cast in one unbroken ring, B, about a wrought-iron pipe, C, which passes entirely around the chill, being inclosed within the substance thereof, and whose ends *c c'* project through the wall of the furnace to connect, respectively, with the supply and waste-water pipes.

The sole or bottom D may be a customary plate of metal.

The fore-plate E is removable, and occupies a gain, *b*, in the upper front side of the ring or chill. Transverse fracture of the chill is prevented by a wrought-iron band or re-enforce, F, which is shrunk around it.

Fracture and warping of my chill are prevented, first, by being cast solidly in one unbroken ring; second, by the wrought band or re-enforce; third, by the wrought pipe through

which the water passes, said pipe being cast solidly within the substance of the chill.

I have had this chill in operation, testing it fully, and have found that a very large percentage of the "fixing" is saved over that consumed in the ordinary boiling-furnace, or, more strictly speaking, the amount of fixing used is much lessened, as the chill tends to keep it cool. Thus the capacity of the furnace is increased as the space occupied by the fixing is decreased. I have also found my chill free from the objection incident to a chill formed in two or more pieces—viz., that the high and varied temperature to which the chill is subjected warps the pieces out of shape, so as to destroy the necessarily close connection between them.

I am aware that chill-boshes for boiling or puddling furnaces have before been made by casting iron upon and around a pipe for water, as described in Wm. Batty's patent, September 24, 1867. This, therefore, I do not broadly claim; but

I do claim as my invention—

1. The chill-bosh for reverberatory furnaces, consisting of a continuous ring, B, cast around the water-pipe C, in combination with the wrought-iron band F, as described.

2. The combination of the continuous cast ring B, pipe C, wrought-iron band F, and fore-plate E, as and for the purposes set forth.

In testimony of which invention I hereunto set my hand.

THOMAS COATES.

Witnesses:

GEO. H. KNIGHT,
JAMES H. LAYMAN.