



US00D522892S

(12) **United States Design Patent**  
**Reymond**

(10) **Patent No.:** **US D522,892 S**

(45) **Date of Patent:** **\*\* Jun. 13, 2006**

(54) **SLIDE CALIPER**

(75) Inventor: **Jean-Claude Reymond**,  
Chavannes-près-Renens (CH)

(73) Assignee: **TESA SA**, Renens (CH)

(\*\*) Term: **14 Years**

(21) Appl. No.: **29/214,049**

(22) Filed: **Sep. 27, 2004**

(30) **Foreign Application Priority Data**

Mar. 26, 2004 (CH) ..... 130445

(51) **LOC (8) Cl.** ..... **10-04**

(52) **U.S. Cl.** ..... **D10/73**

(58) **Field of Classification Search** ..... D10/73;  
33/783-832, DIG. 12

See application file for complete search history.

(56) **References Cited**

**U.S. PATENT DOCUMENTS**

D313,562 S	*	1/1991	Meyer	.....	D10/73
D334,719 S	*	4/1993	Yeo	.....	D10/73
5,477,621 A	*	12/1995	Koizumi et al.	.....	33/784
D377,912 S	*	2/1997	Walser	.....	D10/73
D386,994 S	*	12/1997	Reymond	.....	D10/73
D387,690 S		12/1997	Reymond		

5,722,179 A		3/1998	Zanier		
D401,170 S		11/1998	Reymond		
6,072,318 A		6/2000	Jordil		
D444,083 S	*	6/2001	Ohtani et al.	.....	D10/73
D449,547 S		10/2001	Reymond		
6,724,186 B1	*	4/2004	Jordil	.....	33/708

\* cited by examiner

*Primary Examiner*—Antoine D. Davis

(74) *Attorney, Agent, or Firm*—Pearne & Gordon LLP

(57) **CLAIM**

The ornamental design for a slide caliper, as shown and described.

**DESCRIPTION**

FIG. 1 is a perspective view of my new slide caliper; FIG. 2 is a top view of FIG. 1; FIG. 3 is a bottom view of FIG. 1; FIG. 4 is a right side view of FIG. 1; FIG. 5 is a left side view of FIG. 1; FIG. 6 is a front view of FIG. 1; and, FIG. 7 is a back view of FIG. 1.

The parts shown in broken lines are shown for environmental purposes only and form no part of the claimed design. Portions of the slide caliper are not shown for ease of illustration and to illustrate an indeterminate length.

**1 Claim, 7 Drawing Sheets**

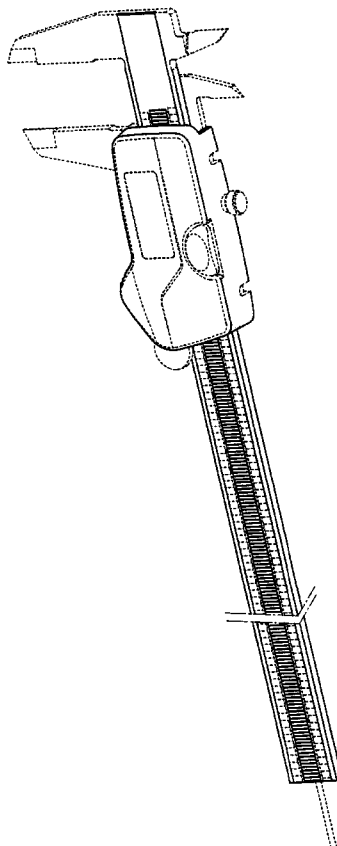

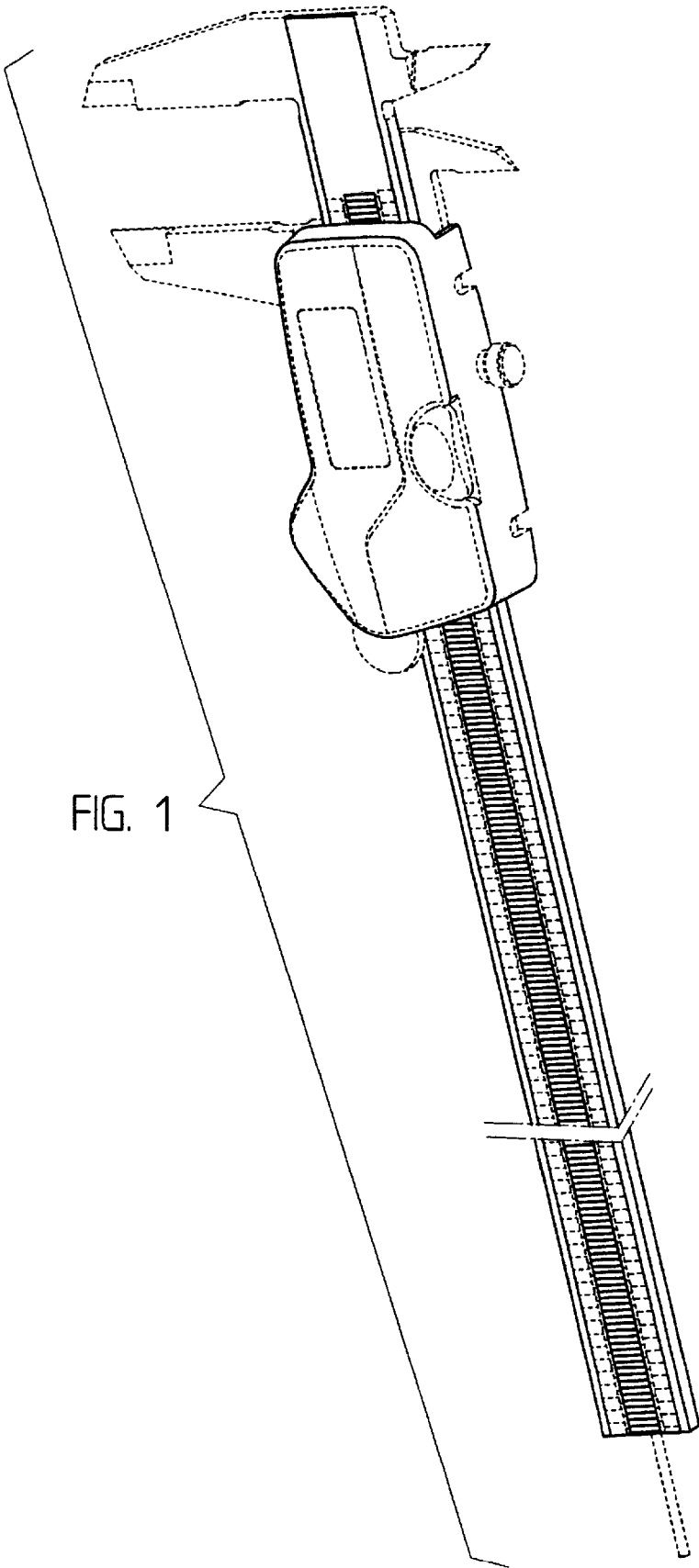
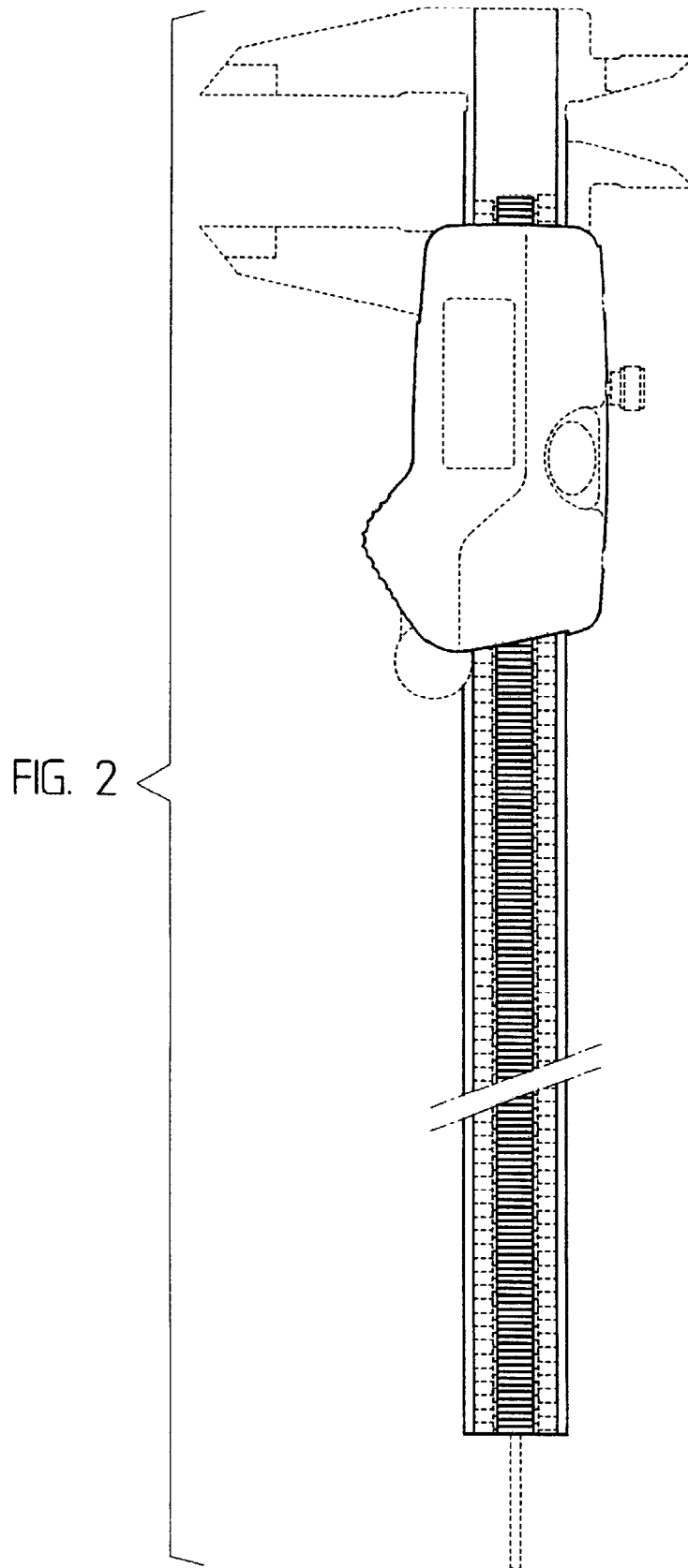

FIG. 1



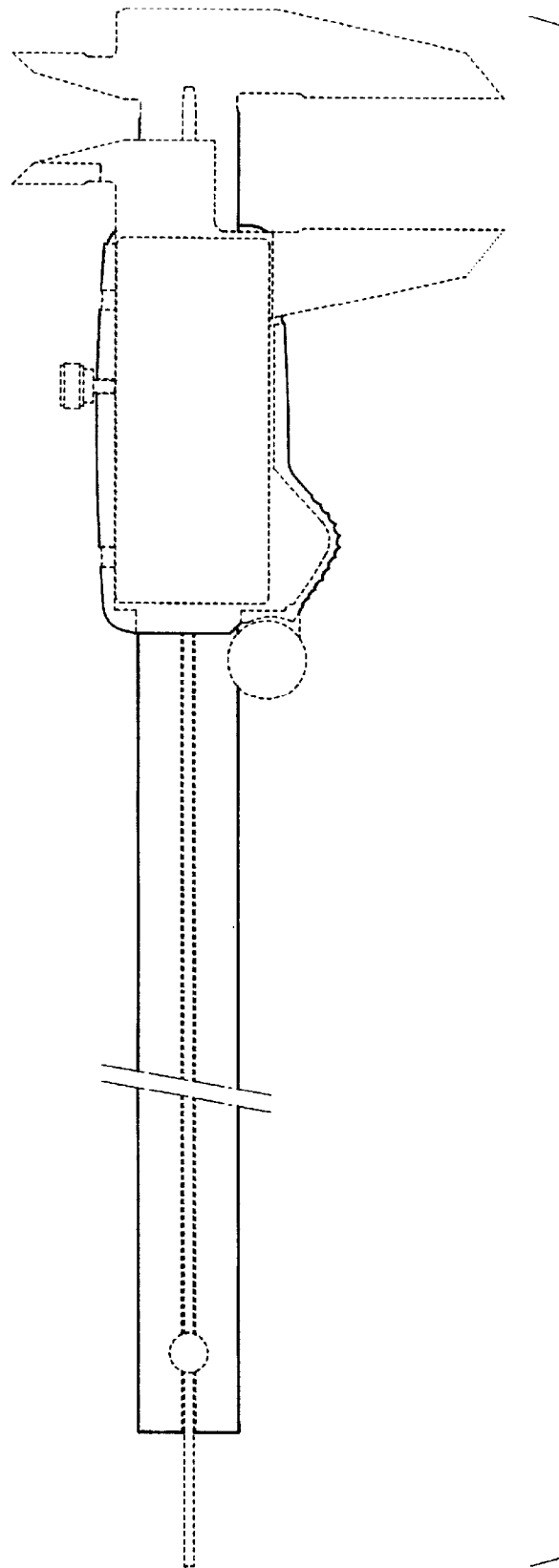
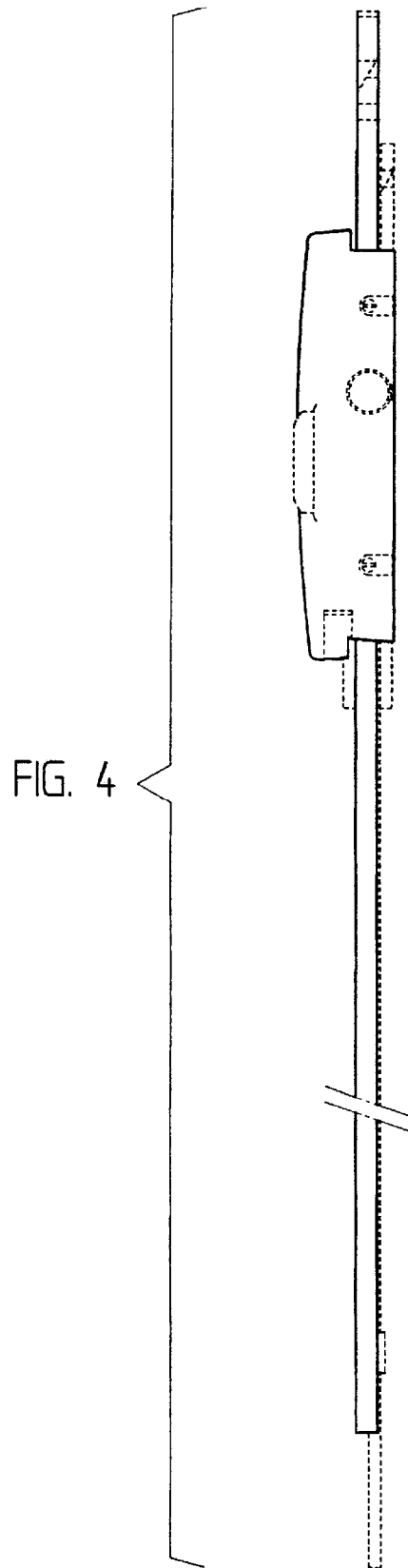

FIG. 3



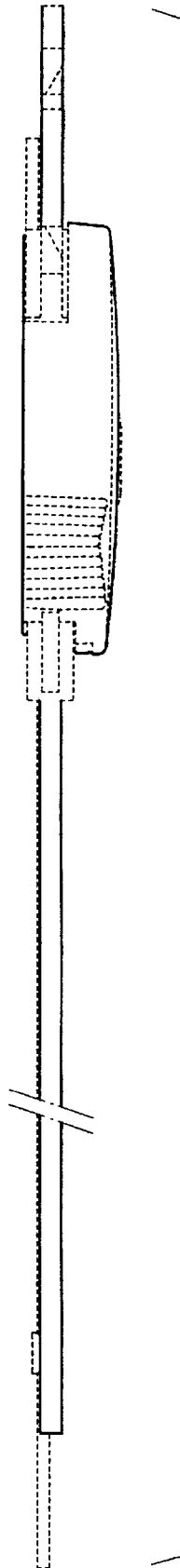

FIG. 5

FIG. 6



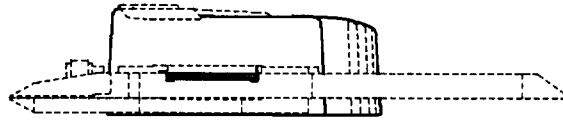

FIG. 7