



(51) International Patent Classification:

A44B 18/00 (2006.01) A61F 13/58 (2006.01)
A61F 13/56 (2006.01) A61F 13/62 (2006.01)

(21) International Application Number:

PCT/IB2023/059818

(22) International Filing Date:

29 September 2023 (29.09.2023)

(25) Filing Language:

English

(26) Publication Language:

English

(30) Priority Data:

2022-158575 30 September 2022 (30.09.2022) JP

(71) Applicant: **3M INNOVATIVE PROPERTIES COMPANY** [US/US]; 3M Center, Post Office Box 33427, Saint Paul, Minnesota 55133-3427 (US).

(72) Inventors: **ARAI, Nobuharu**; 6-7-29 Kitashinagawa, Shinagawa-ku, Tokyo 141-8684 (JP). **FUKUSHI, Marina**; 6-7-29 Kitashinagawa, Shinagawa-ku, Tokyo 141-8684 (JP).

(74) Agent: **GROSS, Kathleen B.** et al.; 3M Center, Office of Intellectual Property Counsel, Post Office Box 33427, Saint Paul, Minnesota 55133-3427 (US).

(81) Designated States (unless otherwise indicated, for every kind of national protection available): AE, AG, AL, AM, AO, AT, AU, AZ, BA, BB, BG, BH, BN, BR, BW, BY, BZ, CA, CH, CL, CN, CO, CR, CU, CV, CZ, DE, DJ, DK, DM, DO, DZ, EC, EE, EG, ES, FI, GB, GD, GE, GH, GM, GT, HN, HR, HU, ID, IL, IN, IQ, IR, IS, IT, JM, JO, JP, KE, KG, KH, KN, KP, KR, KW, KZ, LA, LC, LK, LR, LS, LU, LY, MA, MD, MG, MK, MN, MU, MW, MX, MY, MZ, NA, NG, NI, NO, NZ, OM, PA, PE, PG, PH, PL, PT, QA, RO, RS, RU, RW, SA, SC, SD, SE, SG, SK, SL, ST, SV, SY, TH,

(54) Title: CONNECTING SHEET AND GARMENT ADHERING ARTICLE

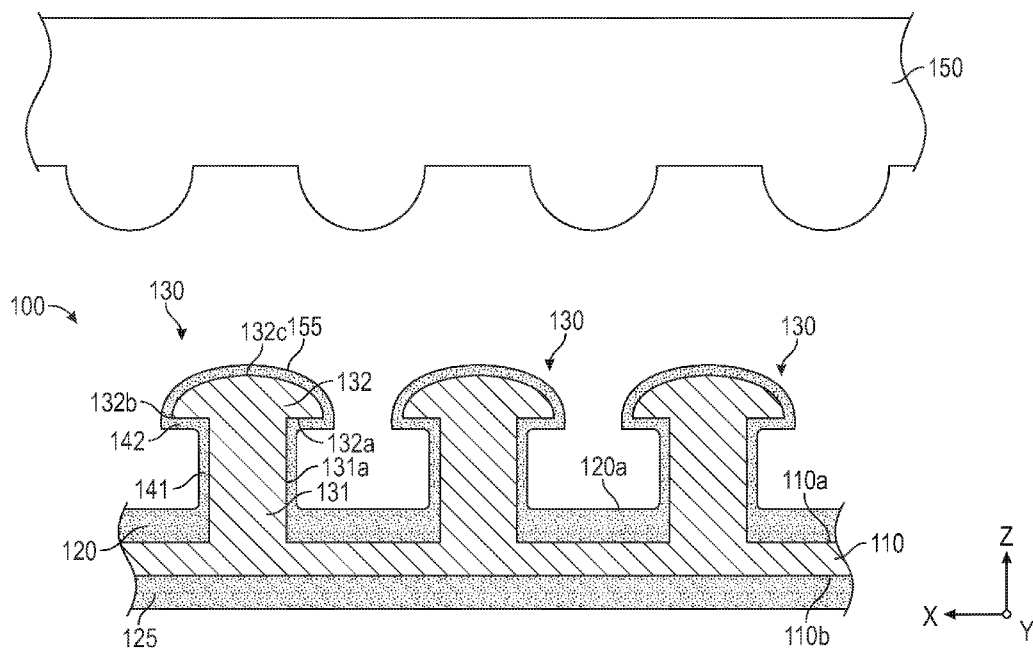

FIG. 2

(57) Abstract: To provide a connecting sheet with appropriate softness as well as a garment adhering article that can be attached to clothing. A connecting sheet connects with a target object by being superimposed on the target object, which includes: a sheet base material having a first main surface and a second main surface; a plurality of hook members protruding from the first main surface of the sheet base material in a first direction arranged mutually separated in a second direction in which the first main surface extends; and an adhesive layer adhered to the hook members, wherein the polyethylene content of the sheet base material and hook member is 15 weight percent or more, and the density of the polymer or polymer mixture of the sheet base material and the hook member is 0.925 g/cm³ or less.



TJ, TM, TN, TR, TT, TZ, UA, UG, US, UZ, VC, VN, WS,
ZA, ZM, ZW.

- (84) Designated States** (*unless otherwise indicated, for every kind of regional protection available*): ARIPO (BW, CV, GH, GM, KE, LR, LS, MW, MZ, NA, RW, SC, SD, SL, ST, SZ, TZ, UG, ZM, ZW), Eurasian (AM, AZ, BY, KG, KZ, RU, TJ, TM), European (AL, AT, BE, BG, CH, CY, CZ, DE, DK, EE, ES, FI, FR, GB, GR, HR, HU, IE, IS, IT, LT, LU, LV, MC, ME, MK, MT, NL, NO, PL, PT, RO, RS, SE, SI, SK, SM, TR), OAPI (BF, BJ, CF, CG, CI, CM, GA, GN, GQ, GW, KM, ML, MR, NE, SN, TD, TG).

Published:

- *with international search report (Art. 21(3))*
- *in black and white; the international application as filed contained color or greyscale and is available for download from PATENTSCOPE*

Brief Description of the Drawings

FIG. 1 is a view illustrating a napkin including a connecting sheet in accordance with an embodiment;

FIG. 2 is a cross sectional view illustrating a part of the connecting sheet in accordance with the

5

FIG. 3A is a diagram depicting a state of attaching a napkin to underwear;

FIG. 3B is a diagram depicting a state of a napkin attached to underwear;

FIG. 4 is a table indicating conditions for samples 1 to 14 prepared for measurement and the measurement results;

10

FIG. 5 is a graph depicting the relationship between PE content of each sample and softness;

FIG. 6 is a table indicating the PE content and mixed polymer density for each sample;

FIG. 7 is a plotted graph of the relationship between PE content and mixed polymer density for each sample;

FIG. 8 is a table describing the measurement method for mixed polymer density;

15

FIG. 9 is a graph for describing the PP-PE ratio measurement; and

FIG. 10 indicates the relationship of the ratio between PE content and peak strength.

Detailed Description

In the following, various embodiments will be described in detail with reference to drawings.

20

Note that the same reference signs are used for the same or corresponding portions in the drawings.

FIG. 1 is a view illustrating a napkin including a connecting sheet according to an embodiment of the present invention. A napkin 1 includes a front surface 1a that faces the skin and has liquid permeability, a back surface 1b (connecting surface) that faces a garment and has liquid impermeability, and connecting sheets 100 provided on the back surface 1b. The back surface 1b is a connecting surface

connected to the garment. In the example illustrated in FIG. 1, the connecting sheets 100 are provided in the plurality of regions of the back surface 1b at intervals. Note that the number of regions where the connecting sheets 100 are provided, the shape of each region, and the dimension of each region are not limited thereto and can be designed as desired. In addition, the article to which the connecting sheets 100 are applied is not limited to the napkin, and may be applied to, for example, a light incontinence pad, a pocket warmer (stuck to garments), or the like. The napkins and light incontinence pads may be collectively referred to as absorbent articles. The absorbent articles are also referred to as garment adhering articles including a pocket warmer or the like stuck to garments.

25

30

Fig. 3A is a top view depicting a state of the napkin 1 being attached to the target object 150.

FIG. 3B is a diagram depicting a state of the napkin 1 attached to a target object 150. Panties 160 are an example of a target object 150. The napkin 1 is attached to the bottom part 161 of the panties 160.

35

Next, a configuration of the connecting sheet 100 will be described with reference to FIG. 2. FIG. 2 is a cross sectional view illustrating a part of the connecting sheet 100 in accordance with an embodiment. For the purpose of explanation, FIG. 2 also illustrates the XYZ Cartesian coordinate system.

The connecting sheet 100 is stacked on a target object 150 such as underwear and connected to the target object 150. As a result, the connecting sheet 100 can fix the napkin 1 to the target object 150 such as a garment. As illustrated in FIG. 2, the connecting sheets 100 each include a sheet base material 110, a first adhesive layer 120, a second adhesive layer 125, and a plurality of hook members 130. In the present embodiment, a direction that is orthogonal to the sheet base material 110 is defined as a Z-axis direction (first direction). A direction that is orthogonal to the Z-axis direction is defined as an X-axis direction, and a direction that is orthogonal to the Z-axis direction and the X-axis direction is defined as a Y-axis direction.

The sheet base material 110 has a substantially sheet-like shape and has a first main surface 110a and a second main surface 110b that are opposed to each other in the Z-axis direction. The sheet base material 110 extends in an XY-plane direction (second direction). In other words, the first main surface 110a and the second main surface 110b extend in the XY-plane direction. The plurality of hook members 130 are formed on the first main surface 110a.

The first adhesive layer 120 is formed on the first main surface 110a of the sheet base material 110. The first adhesive layer 120 is provided so as to fill spaces between the plurality of hook members 130. The first adhesive layer 120 is formed so as to cover the substantially entire surface of the first main surface 110a (except for the positions of the hook members 130). Examples of the material for the first adhesive layer 120 include natural rubber/resin copolymers, synthetic rubber/resin copolymers, and acrylate copolymers. The thickness of the first adhesive layer 120 may be 10 micrometers (μm) or more, or 20 μm or more, and may be 100 μm or less, or 90 μm or less. The applied amount may be 10 grams per square meter (gsm) or more, or 20 gsm or more, and may be 100 gsm or less, or 90 gsm or less. In the state of an adhesive state, the adhesive strength of the first adhesive layer 120 may be 2 Newtons per 25 millimeters (N/25 mm) or more or 4 (N/25 mm) or more and may be 14 (N/25 mm) or less or 8 (N/25 mm) or less. The adhesive strength of the first adhesive layer 120 is a value defined by the method JISZ 0237.

The second adhesive layer 125 is formed on the second main surface 110b of the sheet base material 110. The material for the second adhesive layer 125 is the same adhesive material as the material for the first adhesive layer 120. The first adhesive layer 120 and the second adhesive layer 125 may be formed from the same adhesive material or may be formed from different adhesive materials. The second adhesive layer 125 may be omitted. The thickness of the first adhesive layer 120 may be 10 μm or more or 20 μm or more and may be 120 μm or less or 110 μm or less.

The hook members 130 protrude from the first main surface 110a of the sheet base material 110 in the Z-axis direction (first direction). The hook members 130 are spaced at intervals in the XY-plane

direction in which the first main surface 110a extends. The hook members may be arranged in a grid pattern that is perpendicular to the XY-plane direction and may be arranged in a grid pattern that is oblique from the XY-plane direction, a staggered pattern, a random pattern, and the like. The hook members 130 protrude from the front surface 120a on the Z-axis positive side of the first adhesive layer 120 in the Z-axis direction.

The hook members 130 each include a column part 131 and a head part 132. The column part 131 is a portion that extends from the sheet base material 110 in the Z-axis direction and protrudes from the front surface 120a of the first adhesive layer 120. The head part 132 is a part that spreads from a tip of the column part 131 in the XY-plane direction. Note that the shape of the column part 131 and the head part 132 of all of the hook members 130 in the connecting sheet 100 may be the same (variations in the range of manufacturing errors are allowable) or may be different in different regions.

The hook member 130 includes adhesive material applied parts 141, 142, 155 formed by covering a portion protruding from the first adhesive layer 120 with an adhesive material. Specifically, an outer circumferential surface 131a of the column part 131 is covered with the adhesive material. As a result, the adhesive material applied portion 141 is formed on the outer circumference of the column part 131. Further, a lower surface 132a of the head part 132 is covered with the adhesive material. As a result, the adhesive material applied portion 142 is formed on the lower side of the head part 132. The adhesive material applied portion 142 is formed across the entire region between an inner circumferential end (a connection portion of the column part 131 and the head part 132) and an outer circumferential end 132b on the lower surface 132a of the head part 132. Accordingly, the adhesive material applied portion 142 of the head part 132 further extends to the outer circumferential side than the adhesive material applied portion 141 of the column part 131. An upper surface 132c of the head part 132 is covered with an adhesive. As a result, the adhesive material applied part 155 is formed on the upper side of the head part 132.

Next, materials for the sheet base material 110 and the hook member 130 will be described. The sheet base material 110 and the hook member 130 contain at least polyethylene (PE). The sheet base material 110 and the hook member 130 are composed of, for example, a mixed polymer obtained by adding an additive polymer to a base polymer. Polypropylene (PP) or polypropylene-polyethylene (PP-PE) copolymer can be utilized as the base polymer. Low density polyethylene can be utilized as the additive polymer. The base polymer of the mixed polymer tends to be stiff due to high crystallization of the polymer. On the other hand, low-density resins tend to have low rigidity (soft) due to low crystallization of the polymer. Adjusting the amount of low-density polyethylene added to the base polymer adjusts the polyethylene content and density in the mixed polymer. Polyethylene monomers are preferably derived from plants (sugar cane, and the like).

The polyethylene content of the sheet base material 110 and the hook member 130 is 15 weight percent (wt%) or more and 100 wt% or less, and the density of the mixed polymer of the sheet base

material 110 and the hook member 130 is 0.900 grams per cubic centimeter (g/cm^3) or more and 0.925 g/cm^3 or less. In addition, the polyethylene content of the sheet base material 110 and the hook member 130 may be 20 wt% or more and 95 wt% or less, and the density of the mixed polymer of the sheet base material 110 and the hook member 130 may be 0.901 g/cm^3 or more and 0.920 g/cm^3 or less. In addition, 5 the polyethylene content of the sheet base material 110 and the hook member 130 may be 25 wt% or more and 60 wt% or less, and the density of the mixed polymer of the sheet base material 110 and the hook member 130 may be 0.902 g/cm^3 or more and 0.915 g/cm^3 or less.

The thickness of the sheet base material 110 may be 70 μm or less or 50 μm or less. In addition, the thickness of the sheet base material 110 may be 10 μm or more or 20 μm or more. The average height 10 of the hook member 130 from the first main surface 110a may be 170 μm or more or 90 μm or more. The average height of the hook member 130 from the first main surface 110a may be 330 μm or less or 310 μm or less. The diameter of the column part 131 of the hook member 130 may be 100 μm or more and may be 150 μm or more. The diameter of the column part 131 of the hook member 130 may be 350 μm or less and may be 250 μm or less. In addition, the density in which the hook members 130 are arranged may 15 be, for example, approximately 500 to 5000 per square inch (77.5 to 775 per square centimeter) or approximately 1600 to 3500 per square inch (248 to 542 per square centimeter).

The shear force of the connecting sheet 100 connected to the target object 150 is a parameter representing the difficulty of displacement of the napkin 1 connected to the object 150 via the connecting sheet 100. The shear force of the connecting sheet 100 connected to the target object 150 may be 0.9 N/5 20 cm^2 or more and may be 2.4 N/5 cm^2 or more. In addition, the shear force of the connecting sheet 100 connected to the target object 150 may be 9 N/5 cm^2 or less and may be 8 N/5 cm^2 or less.

The initial tack of the connecting sheet 100 is a parameter indicating sticky feel. The initial tack may be 0.01 N/6.25 cm^2 or more and may be 0.02 N/6.25 cm^2 or more. The initial tack may be 0.1 N/6.25 25 cm^2 or less and may be 0.09 N/6.25 cm^2 or less.

As a measurement method for measuring peel force for each sample from underwear, underwear 25 was secured to a stainless steel panel and then a sample was placed and then roller pressure of 7 kilograms (kg) was reciprocated once and measurement was performed by peeling performed at a peel speed of 300 millimeters (mm)/minute and 90°. The surface of underwear “PGG340” manufactured by WACOAL HOLDINGS CORP. that was in contact with skin was used as the target object for this 30 measurement. The size of the sheet base material was 25 mm \times 20 mm.

In addition, as dynamic shear strength, underwear was secured to a stainless steel panel, shear 35 was caused by pulling at a 180° direction (direction along 25 mm side) with a crosshead speed of 30 mm/minute after one reciprocation of a 2 kg roller pressure, and the tensile strength was measured at that time. The surface of underwear “EC4033” manufactured by WACOAL HOLDINGS CORP. that was in contact with skin was used as the target object for this measurement. The size of the sheet base material was 25 mm \times 20 mm.

In addition, a stainless steel T-shaped block was provided for the initial tack measurement. The pressing surface of the T-shaped block was set to a size of 25 mm x 25 mm. The pressing surface of the T-shaped block is pressed onto the hook member 130 covered with adhesive. Herein, with the measurement value of a force when a T-shaped block is pressed upward at 300 mm/min by pressing 2 kg x 5 seconds on a hook member 130 without adhesive as a reference value, the difference in a measurement value of a force when a T-shaped block is pressed upward at 300 mm/min by pressing 2 kg x 5 sec on the hook member 130 when covered with adhesive and this reference value was calculated as the initial tack.

The connecting sheet 100 may have a softness of 0.06 gram-force(gf)*cm²/cm or less and may be 0.05 gf*cm²/cm or less. The softness of the connecting sheet 100 may be 0.01 gf*cm²/cm or more and may be 0.02 gf*cm²/cm or more. The softness of the connecting sheet 100 is measured by a series of devices called KES (Kawabata Evaluation System). The results measured by KES indicate the bendability of the connecting sheet 100.

Next, with reference to FIG. 4 to FIG. 10, the relationship between the softness of the connecting sheet 100 and the content and density of polyethylene in the polymer mixture will be described. FIG. 4 is a table depicting conditions of samples 1 to 14 prepared for measurement and the measurement results. The height of the hook member was 420 μm, and the diameter of the head part was 290 μm. "Quintac 3620/Quintone M100//Irganox1076 = 60/39/1" was used as the adhesive. The amount of adhesive applied was set to 93 g/m².

In the table of FIG. 4, the base polymer used for each sample is noted in the "base polymer" column. The additional polymer added is noted in the "PE structure" column. "Hook member density" notes the density of the hook member. The thickness of the sheet base material is noted in the "sheet base material thickness" column. With the overall polymer mixture as 100 wt%, the base polymer content is noted in the "base polymer content" column. With the overall polymer mixture as 100 wt%, the added polymer PE content is noted in the "PE resin content" column. With the overall polymer mixture as 100 wt%, the PE content is noted in the "PE content" column. The "base polymer density" column notes the density of the base polymer. The "PE density" column notes the density of the added polymer PE. The "mixed polymer density" column notes the density of the mixed polymer as a whole. The "softness" column notes the measurement results for softness.

Of the items in the table described above, the density measurement method will be described with reference to FIG. 8. FIG. 8 indicates a measurement method of a mixed polymer density with regards to samples 1, 6 and 7. The mixed polymer density utilizes a calculated value of the average measurement value using the gravitational force buoyancy method and the measurement value using the gas replacement method. The gravitational force buoyancy method is a method for measuring the density based on the Archimedes principle of an object in a liquid receiving a buoyancy force equivalent to the weight of the liquid displaced by the object. Air integrated in the sample is a cause of variation for this

method, leading to error within 1%. The gas replacement method is a measurement method of the density that uses Boyle's law ($PV=\text{constant}$).

Of the items in the table described above, the measurement method of the ratio of PP and PE will be described with reference to FIG. 9 and FIG. 10. In FIG. 9, infrared spectroscopy (IR) measurements were made for a "base polymer + added polymer PE at 50 wt%" sample, a "base polymer + added polymer PE at 25 wt%" sample, and a "base polymer". As a result, a PP derived peak positioned at 997 cm^{-1} was observed ("A" in figure) and a PE derived peak positioned at 720 cm^{-1} was observed ("B" in figure). The intensity of these PP derived peaks and the intensity of the PE derived peaks were obtained and the ratio of the two was calculated. FIG. 10 depicts the relationship between the PE content and peak intensity ratio.

A method for measuring softness will be described. Each sample was made into a 25 mm x 25 mm test piece, set in a bending device (Kawabata Evaluation System (KES)), and the softness of each sample was measured.

FIG. 5 depicts the relationship between the PE content of the added polymer and the softness measurement results. FIG. 5 compares the results when the sheet base material thickness was 95 μm and the results when the sheet base material thickness was 45 μm . It was confirmed that increasing PE content improved softness of the connecting sheet regardless of the sheet base material thickness.

FIG. 6 indicates the PE structure for each sample, PE content, and mixed polymer density. FIG. 7 is a plotted graph of the relationship between PE content and mixed polymer density for each sample. PE content and mixed polymer density preferred range are set based on the plot results of each sample. FIG. 7 depicts a first range indicating a preferred range, a second range indicating a more preferred range, and a third range indicating an even more preferred range. The PE content for the first range is 15 wt% or more and 100 wt% or less. The mixed polymer density for the first range is 0.900 g/cm^3 or more and 0.925 g/cm^3 or less. The PE content for the second range is 20 wt% or more and 95 wt% or less. The mixed polymer density for the second range is 0.901 g/cm^3 or more and 0.920 g/cm^3 or less. In addition, the PE content for the third range is 25 wt% or more and 60 wt% or less. The mixed polymer density for the third range is 0.902 g/cm^3 or more and 0.915 g/cm^3 or less.

Next actions and effects of the connecting sheet 100 in accordance with the present embodiment will be described.

A connecting sheet 100 that connects with a target object 150 by being superimposed on the target object 150, includes: a sheet base material 110 having a first main surface 110a and a second main surface 110b; a plurality of hook members 130 protruding from the first main surface 110a of the sheet base material 110 in a first direction arranged mutually separated in a second direction in which the first main surface 110a extends; and an adhesive layer 120 adhered to the hook members 130, wherein the polyethylene content of the sheet base material 110 and hook member 130 is 15 wt% or more, and the

density of the polymer mixture of the sheet base material 110 and the hook member 130 is 0.925 g/cm^3 or less.

The connecting sheet 100 includes a plurality of hook members 130 protruding from the first main surface 110a of the sheet base material 110 in the first direction and the adhesive layer 120 adhered to the hook members 130. Therefore, the connecting sheet 100 is connected to the target object 150 by the adhesiveness of the hook members 130 and the adhesive layer 120. Here, the polyethylene content of the sheet base material and the hook members is 15 wt% or more and the mixed polymer density of the sheet base material and the hook member is 0.925 g/cm^3 or less. In this case, adjusting the polyethylene content and the mixed polymer density enables achieving an appropriate softness of the sheet base material and the hook members. Thus, a connecting sheet with suitable softness can be provided.

In some embodiments, the polyethylene content of the sheet base material 110 and the hook members 130 is 20 to 95 wt%, and the mixed polymer density of the sheet base material 110 and the hook members 130 is 0.901 to 0.920 g/cm^3 .

The thickness of the sheet base material may be $70 \mu\text{m}$ or less. In this case, it is possible to suppress hardening of the connecting sheet due to excessive thickness of the sheet base material.

The shear force of the connecting sheet connected to the target object may be 0.9 N/5 cm^2 or more. In this case, the connecting sheet can be used to prevent the garment adhering article attached to clothing connected to the target object from shifting.

Initial tack may be between 0.01 and 0.1 N/6.25 cm^2 . In this case, the connecting sheet can be provided with appropriate feel.

The softness may be $0.06 \text{ gf}\cdot\text{cm}^2/\text{cm}$ or less. In this case, the softness of the connecting sheet can be set within an appropriate range.

The garment adhering article is provided with the aforementioned connecting sheet on the connecting surface connected to the garment. In this case, when the connecting sheet touches the user's skin, damage to the skin can be reduced.

The present invention is not intended to be limited to the embodiments described above.

For example, the shape of the hook members is not limited to the embodiment described above and may be any shape. In other words, as long as the hook member has the column part and the head part and the adhesive material layer can be formed on the lower surface of the head part, the shape of the hook member is not particularly limited.

[Aspect 1]

A connecting sheet that connects with a target object by being superimposed on the target object, includes:

a sheet base material having a first main surface and a second main surface;

a plurality of hook members protruding from the first main surface of the sheet base material in a first direction arranged mutually separated in a second direction in which the first main surface extends; and

5 an adhesive layer adhered to the hook members; wherein the polyethylene content of the sheet base material and hook member is 15 wt% or more, and

the density of the polymer mixture of the sheet base material and the hook member is 0.925 g/cm³ or less.

[Aspect 2]

10 The connecting sheet according to aspect 1, wherein the polyethylene content of the sheet base material and the hook member is 20 to 95 wt% and the density of the polymer mixture of the sheet base material and the hook member is 0.901 to 0.920 g/cm³.

[Aspect 3]

15 The connecting sheet according to aspect 1 or 2, wherein the thickness of the sheet base material is 70 μm or less.

[Aspect 4]

20 The connecting sheet according to any one of aspects 1 to 3, wherein the shear force of the connecting sheet connected to the target object is 0.9 N/5 cm² or more.

[Aspect 5]

25 The connecting sheet according to any one of aspects 1 to 4, having an initial tack of 0.01 to 0.1 N/6.25 cm².

[Aspect 6]

The connecting sheet according to any one of aspects 1 to 5, having a softness of 0.06 gf*cm²/cm or less.

30 [Aspect 7]

A garment adhering article comprising the connecting surface described in any one of aspects 1 to 6 on a surface connected to a garment.

[Reference Signs List]: 1. Napkin, 100. Connecting sheet, 110. Sheet base material, 110a. First main surface, 110b. Second main surface, 120. First adhesive layer, 125. Second adhesive layer, 130. Hook member, 150. Target object

What is claimed is:

1. A connecting sheet that connects with a target object by being superimposed on the target object, comprising:

5 a sheet base material having a first main surface and a second main surface;

a plurality of hook members protruding from the first main surface of the sheet base material in a first direction arranged mutually separated in a second direction in which the first main surface extends; and

10 an adhesive layer adhered to the hook members, wherein polyethylene the content of the sheet base material and hook member is 15 weight percent or more, and the density of the polymer or polymer mixture of the sheet base material and the hook member is 0.925 g/cm^3 or less.

2. The connecting sheet according to claim 1, wherein the density of the polymer or polymer mixture of the sheet base material and the hook member is 0.900 g/cm^3 or more.

15

3. The connecting sheet according to claim 1 or 2, wherein the polymer mixture comprises polyethylene and polypropylene.

4. The connecting sheet according to any one of claims 1 to 3, wherein the polyethylene content of the sheet base material and the hook member is in a range from 20 weight percent to 95 weight percent.

20

5. The connecting sheet according to any one of claims 1 to 4, wherein the density of the polymer or polymer mixture of the sheet base material and the hook member is in a range from 0.901 g/cm^3 to 0.920 g/cm^3 .

25

6. The connecting sheet according to any one of claims 1 to 5, wherein the polyethylene content of the sheet base material and the hook member is 25 weight percent or more and 60 weight percent or less.

7. The connecting sheet according to any one of claims 1 to 6, wherein the density of the polymer or polymer mixture of the sheet base material and the hook member is 0.902 g/cm^3 or more and 0.915 g/cm^3 or less.

30

8. The connecting sheet according to any one of claims 1 to 7, wherein the thickness of the sheet base material is $70 \text{ }\mu\text{m}$ or less.

35

9. The connecting sheet according to any one of claims 1 to 8, wherein the shear force of the connecting sheet connected to the target object is 0.9 N/5 cm^2 or more.
10. The connecting sheet according to any one of claims 1 to 9, having an initial tack of 0.01 N/6.25 cm^2 to 0.1 N/6.25 cm^2 .
11. The connecting sheet according to any one of claims 1 to 10, having a softness of $0.06 \text{ gf*cm}^2/\text{cm}$ or less.
12. A garment-adhering article comprising the connecting surface described in any one of claims 1 to 11 on a surface connected to a garment.

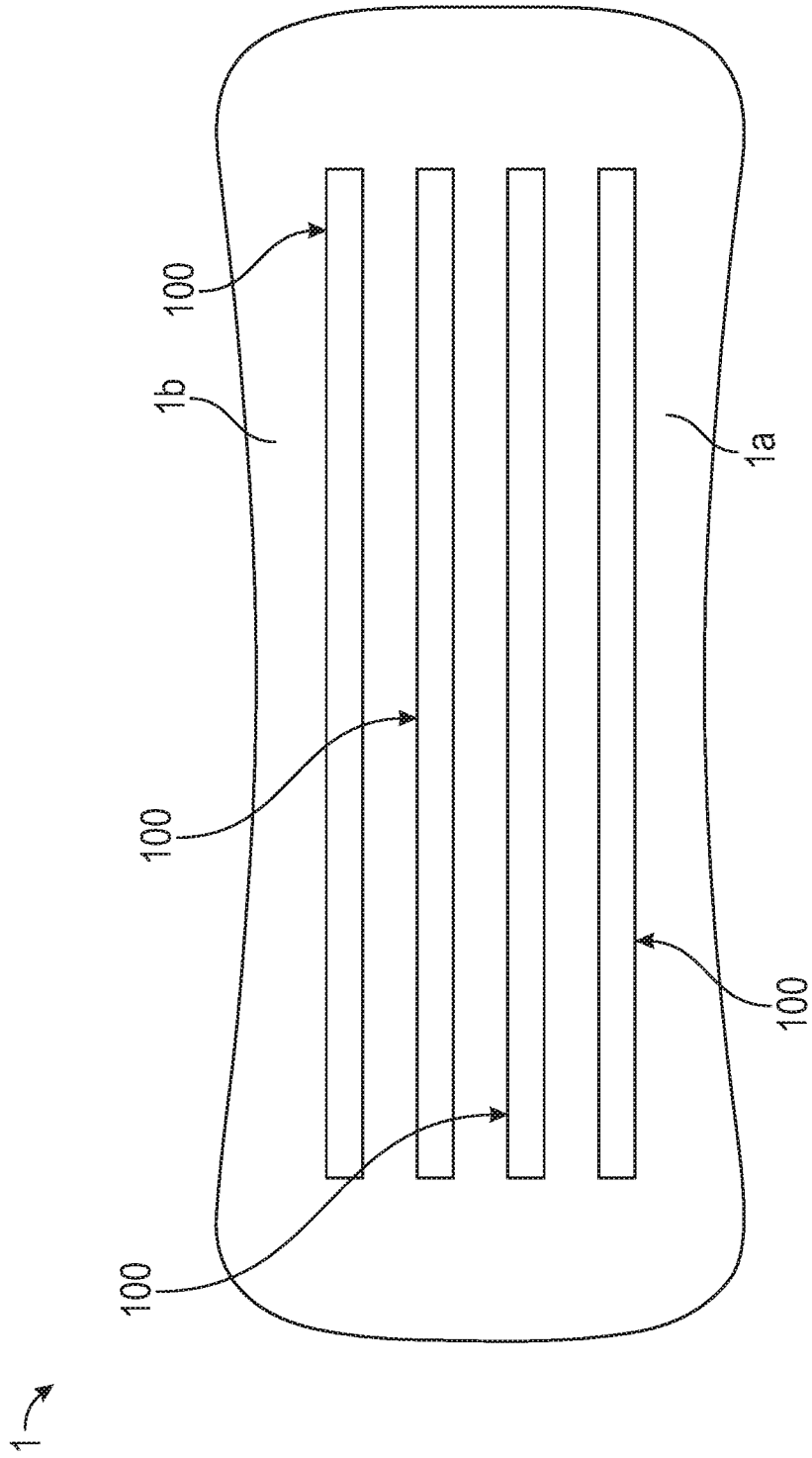

FIG. 1

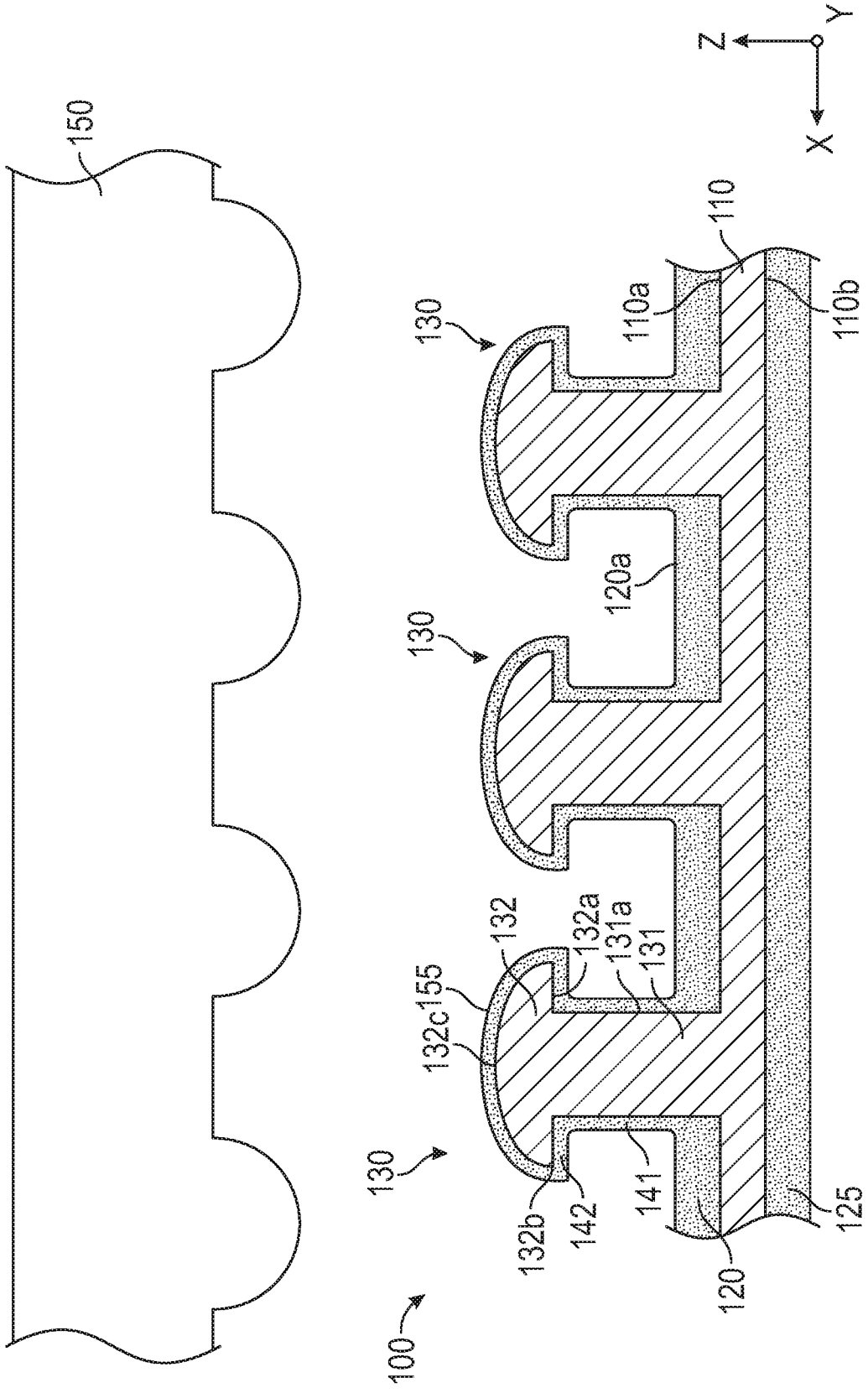
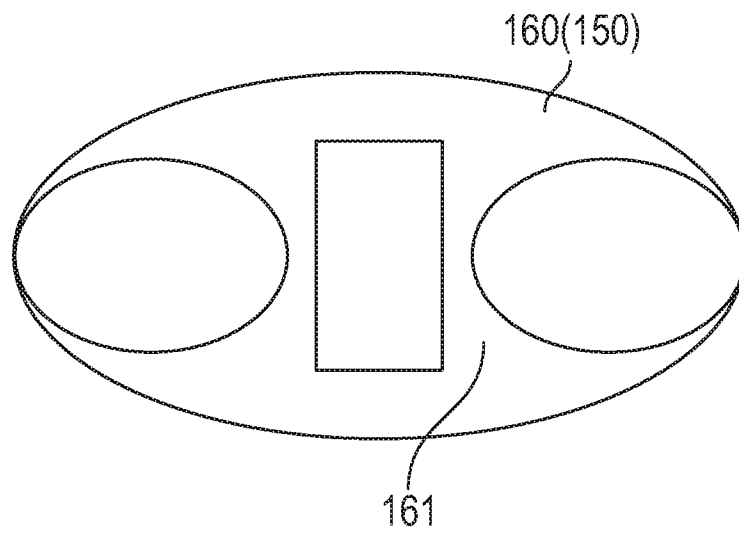
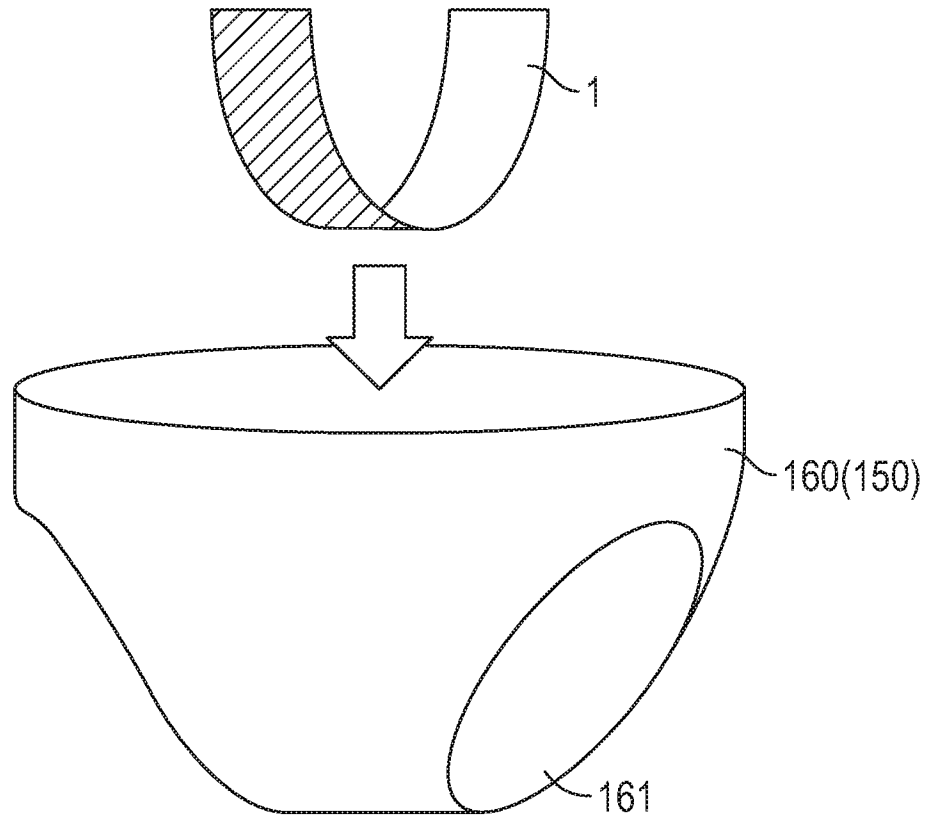

FIG. 2



Sample ID	Base Polymer	PE Structure	Hook Member Density (ppi)	Sheet Base Material Thickness (μm)	Base Polymer Content (wt%)	PE Resin Content (wt%)	PE Content (wt%)	Base Polymer Density (g/cm ³)	PE Density (g/cm ³)	Mixed Polymer Density (g/cm ³)	Polymer Softness (gf*cm ² /cm)
1 (Comparative Example)	PP-PE Copolymer	N/A	1600	95	100	0	10	0.9		0.9	0.084
2	PP-PE Copolymer	Low Density PE	1600	95	75	25	32.5	0.9	0.922	0.9055	0.071
3	PP-PE Copolymer	Low Density PE	1600	95	50	50	55	0.9	0.922	0.911	0.06
4	PP-PE Copolymer	Low Density PE	1600	95	75	25	32.5	0.9	0.922	0.9055	0.065
5	PP-PE Copolymer	Low Density PE	1600	95	50	50	55	0.9	0.922	0.911	0.055
6	PP-PE Copolymer	Low Density PE	1600	95	75	25	32.5	0.9	0.918	0.9045	0.069
9	PP-PE Copolymer	Low Density PE	1600	95	50	50	55	0.9	0.918	0.909	0.041
10 (Comparative Example)	PP-PE Copolymer	Low Density PE	1600	95	50	50	55	0.9	0.961	0.9305	0.077
11	PP-PE Copolymer	N/A	3500	45	100	0	10	0.9	0	0.9	0.062
12	PP-PE Copolymer	N/A	3500	37	100	0	10	0.9	0	0.9	0.012
13	PP-PE Copolymer	Low Density PE	3500	45	75	25	32.5	0.9	0.922	0.906	0.013
14	PP-PE Copolymer	Low Density PE	3500	45	50	50	55	0.9	0.922	0.911	0.0043

FIG. 4

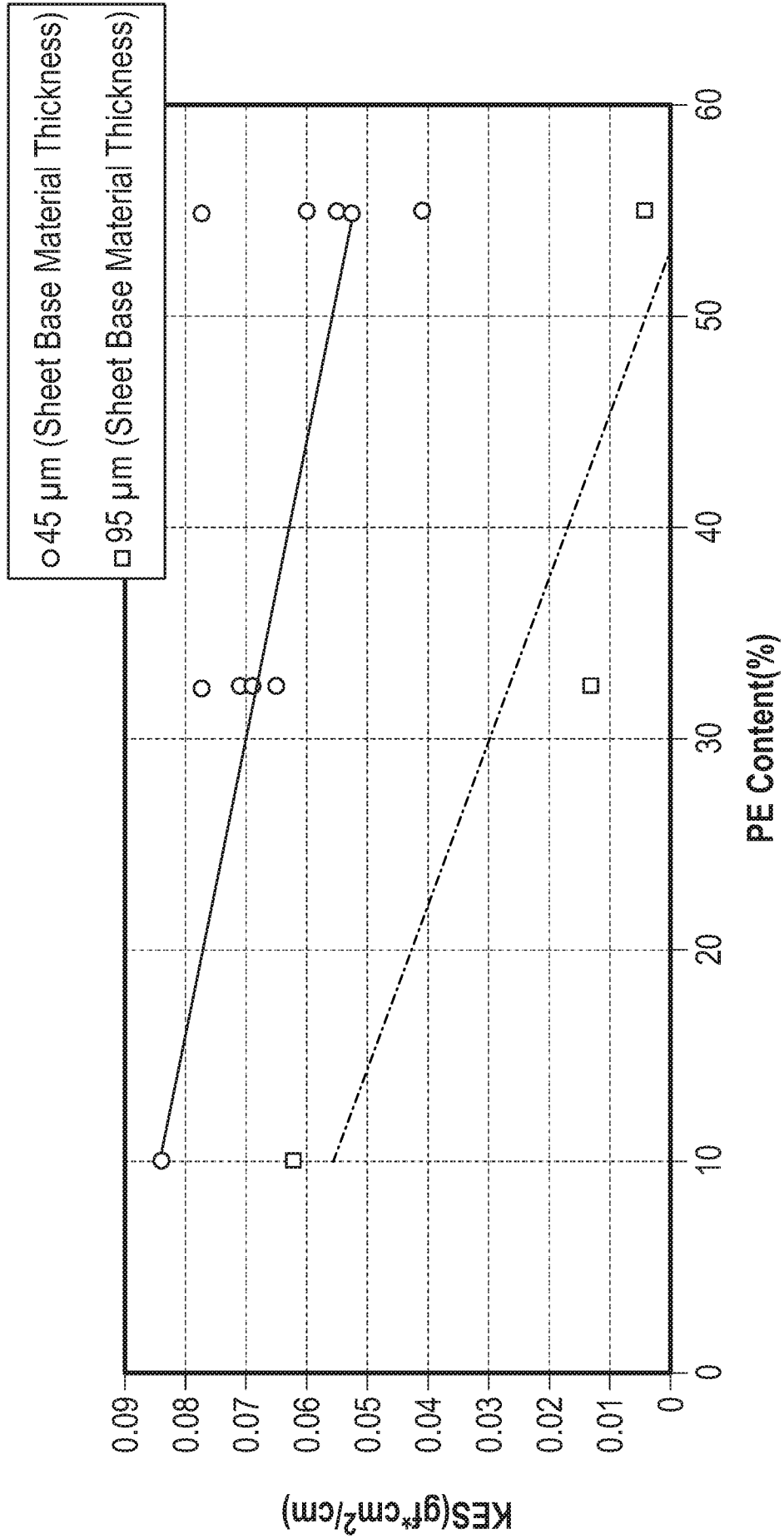

FIG. 5

Sample ID	PE Structure	PE Content (wt %)	Mixed Polymer Density (g/cm ³)
1(Ref)	PE Structure	10.0	0.9000
2	Low Density PE	32.5	0.9055
3	Low Density PE	55.0	0.9110
4	Low Density PE	32.5	0.9058
5	Low Density PE	55.0	0.9115
6	Low Density PE	32.5	0.9055
7	Low Density PE	55.0	0.9110
8	Low Density PE	32.5	0.9045
9	Low Density PE	55.0	0.9090
10(Ref)	Low Density PE	55.0	0.9305
11	Low Density PE	100.0	0.9220
12	Low Density PE	100.0	0.9230
13	Low Density PE	100.0	0.9220
14	Low Density PE	100.0	0.9180

FIG. 6

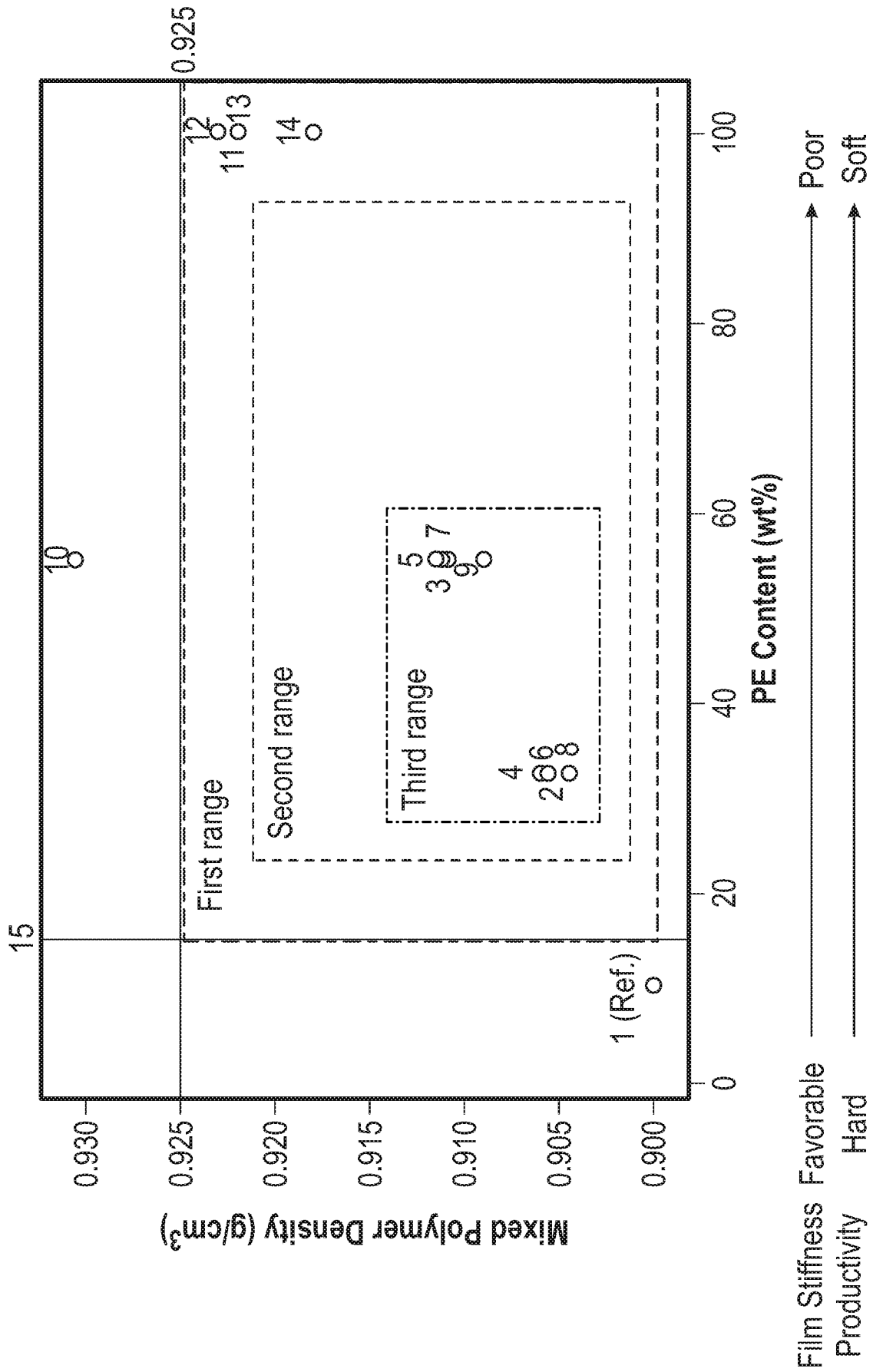

FIG. 7

Sample ID	PE Content (%)	Mixed Polymer Density		
		Calculated Value	Gravitational Force Buoyancy Method	Gas Replacement Method
1	10	0.9	0.8924	0.9049
6	32.5	0.9055	0.9009	0.8989
7	55	0.911	0.906	0.9084
Unit : g/cm ³				

FIG. 8

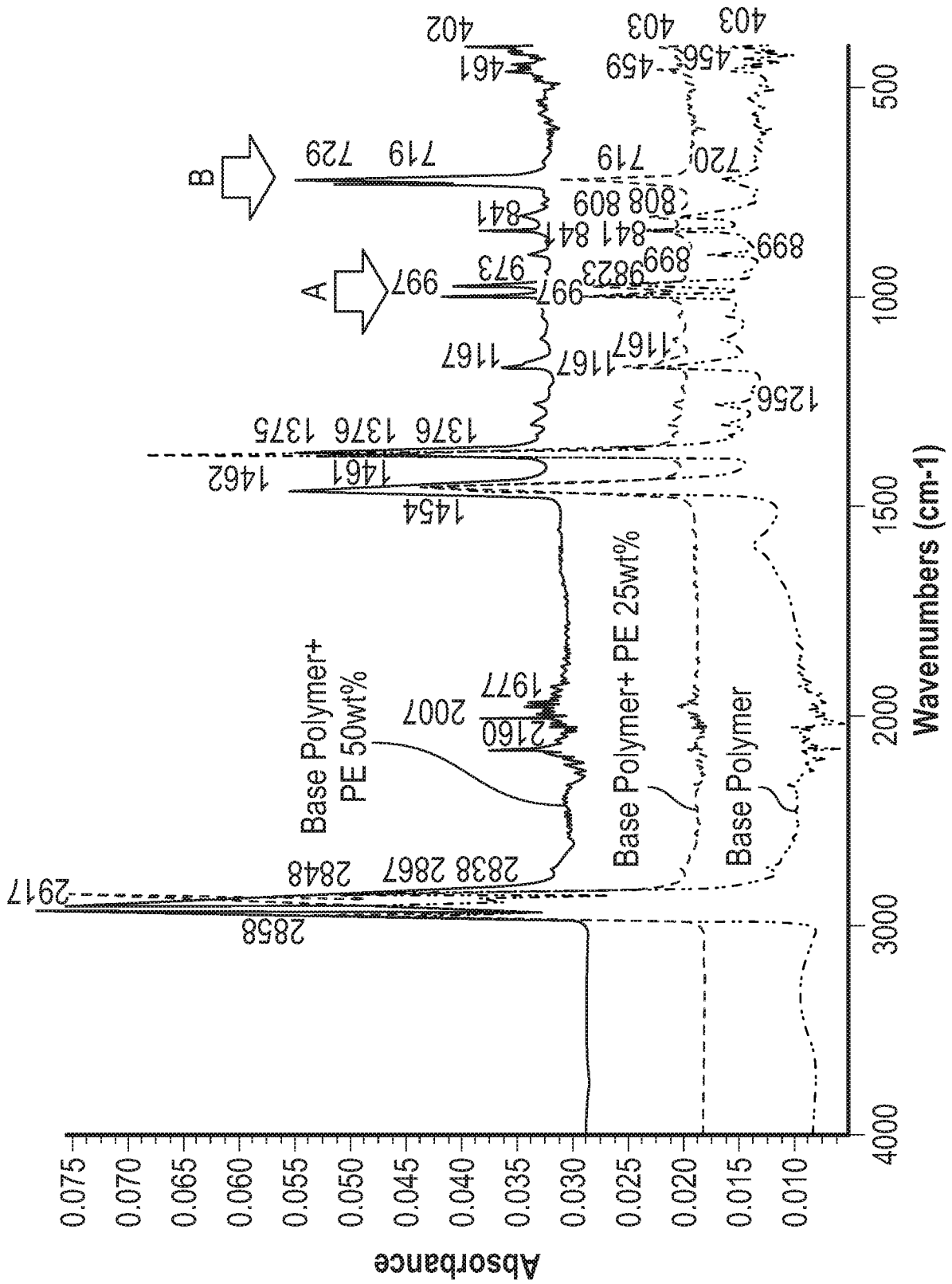

FIG. 9

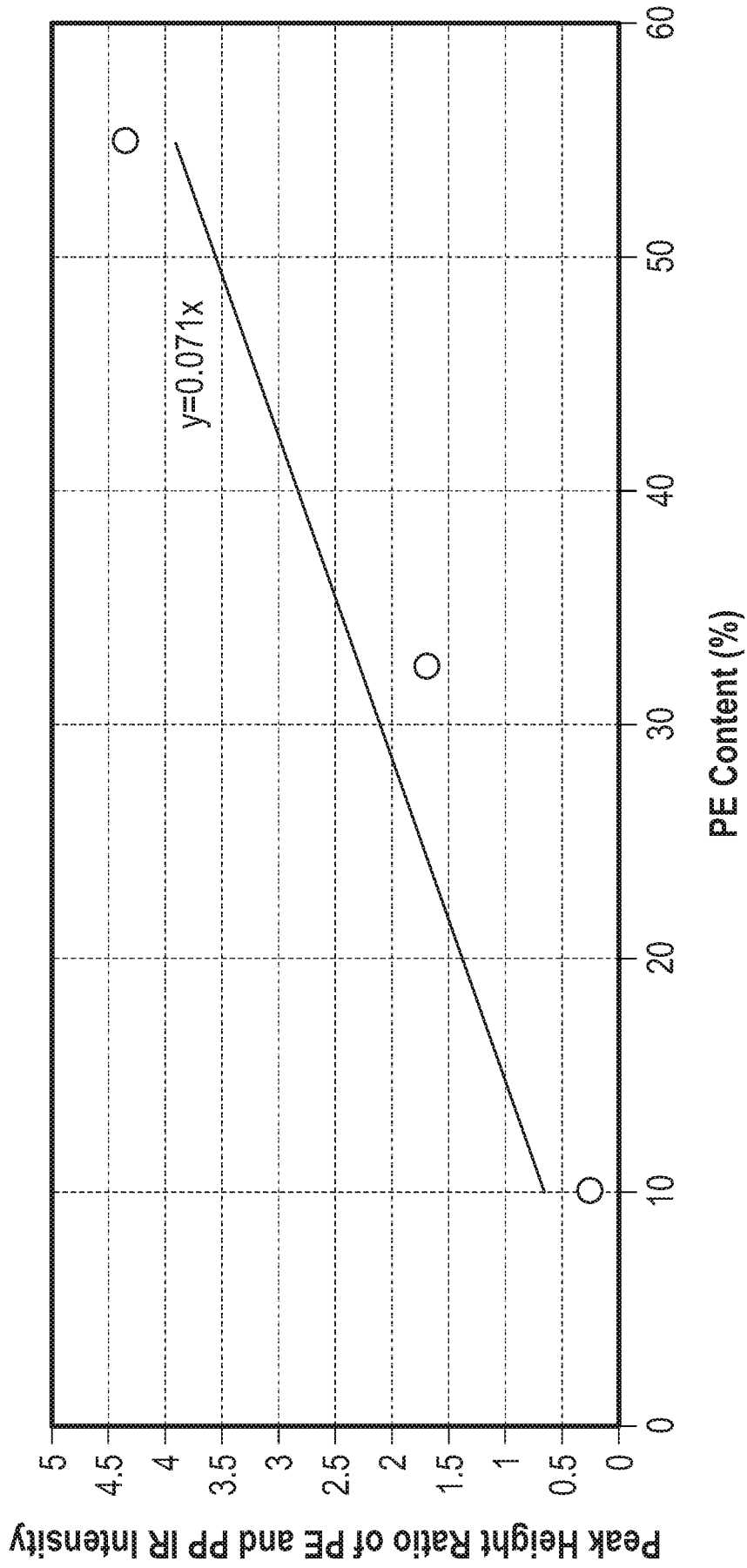

FIG. 10

INTERNATIONAL SEARCH REPORT

International application No PCT/IB2023/059818

A. CLASSIFICATION OF SUBJECT MATTER
INV. A44B18/00 A61F13/56 A61F13/58 A61F13/62
ADD.

According to International Patent Classification (IPC) or to both national classification and IPC

B. FIELDS SEARCHED
 Minimum documentation searched (classification system followed by classification symbols)
A61F A44C A44B

Documentation searched other than minimum documentation to the extent that such documents are included in the fields searched

Electronic data base consulted during the international search (name of data base and, where practicable, search terms used)
EPO-Internal, WPI Data

C. DOCUMENTS CONSIDERED TO BE RELEVANT

Category*	Citation of document, with indication, where appropriate, of the relevant passages	Relevant to claim No.
X	EP 0 393 953 A2 (MINNESOTA MINING & MFG [US]) 24 October 1990 (1990-10-24)	1-12
Y	page 2, line 48 - page 5, line 14 examples figures 1,2	1-12
Y	EP 0 894 448 A1 (MINNESOTA MINING & MFG [US]) 3 February 1999 (1999-02-03) figures paragraphs [0015], [0016], [0020] - [0024]	1-12
Y	WO 2019/043640 A1 (3M INNOVATIVE PROPERTIES CO [US]) 7 March 2019 (2019-03-07) page 4, line 12 - page 12, line 14 figures 3, 7	1-12
	----- -/--	

Further documents are listed in the continuation of Box C. See patent family annex.

* Special categories of cited documents :

"A" document defining the general state of the art which is not considered to be of particular relevance "E" earlier application or patent but published on or after the international filing date "L" document which may throw doubts on priority claim(s) or which is cited to establish the publication date of another citation or other special reason (as specified) "O" document referring to an oral disclosure, use, exhibition or other means "P" document published prior to the international filing date but later than the priority date claimed	"T" later document published after the international filing date or priority date and not in conflict with the application but cited to understand the principle or theory underlying the invention "X" document of particular relevance; the claimed invention cannot be considered novel or cannot be considered to involve an inventive step when the document is taken alone "Y" document of particular relevance; the claimed invention cannot be considered to involve an inventive step when the document is combined with one or more other such documents, such combination being obvious to a person skilled in the art "&" document member of the same patent family
----------------------------------------------------------------------------------------------------------------------------------------------------------------------------------------------------------------------------------------------------------------------------------------------------------------------------------------------------------------------------------------------------------------------------------------------------------------------------------------------------------------------------------------------------------------------------	------------------------------------------------------------------------------------------------------------------------------------------------------------------------------------------------------------------------------------------------------------------------------------------------------------------------------------------------------------------------------------------------------------------------------------------------------------------------------------------------------------------------------------------------------------------------------------------------------------------------------------------------------------------------------------------

Date of the actual completion of the international search 20 November 2023	Date of mailing of the international search report 07/12/2023
--------------------------------------------------------------------------------------	-------------------------------------------------------------------------

Name and mailing address of the ISA/ European Patent Office, P.B. 5818 Patentlaan 2 NL - 2280 HV Rijswijk Tel. (+31-70) 340-2040, Fax: (+31-70) 340-3016	Authorized officer Schmitt-Humbert, C
----------------------------------------------------------------------------------------------------------------------------------------------------------------------	-----------------------------------------------------

INTERNATIONAL SEARCH REPORT

International application No
PCT/IB2023/059818

C(Continuation). DOCUMENTS CONSIDERED TO BE RELEVANT		
Category*	Citation of document, with indication, where appropriate, of the relevant passages	Relevant to claim No.
Y	US 5 933 927 A (MILLER PHILIP [US] ET AL) 10 August 1999 (1999-08-10) column 5, line 64 - column 7, line 43 -----	1-12

INTERNATIONAL SEARCH REPORT

Information on patent family members

International application No

PCT/IB2023/059818

Patent document cited in search report	Publication date	Patent family member(s)	Publication date	
EP 0393953	A2	24-10-1990	AU 613553 B2	01-08-1991
			BR 9001729 A	04-06-1991
			CA 2012561 A1	17-10-1990
			DE 69004144 T2	19-05-1994
			EP 0393953 A2	24-10-1990
			ES 2045801 T3	16-01-1994
			JP 2603743 B2	23-04-1997
			JP H02298569 A	10-12-1990
			US 4959265 A	25-09-1990
			ZA 902283 B	28-12-1990

EP 0894448	A1	03-02-1999	AU 748252 B2	30-05-2002
			BR 9810833 A	25-07-2000
			CA 2297461 A1	11-02-1999
			DE 69704706 T2	07-02-2002
			EP 0894448 A1	03-02-1999
			ES 2159071 T3	16-09-2001
			JP 2001511377 A	14-08-2001
			KR 20010022450 A	15-03-2001
			TW 513292 B	11-12-2002
			WO 9905929 A1	11-02-1999

WO 2019043640	A1	07-03-2019	JP 2019041987 A	22-03-2019
			TW 201934095 A	01-09-2019
			WO 2019043640 A1	07-03-2019

US 5933927	A	10-08-1999	AR 013218 A1	13-12-2000
			AU 729013 B2	25-01-2001
			DE 69720293 T2	25-09-2003
			EP 1021105 A1	26-07-2000
			JP 2001510058 A	31-07-2001
			JP 2010088935 A	22-04-2010
			KR 20010021914 A	15-03-2001
			TW 380050 B	21-01-2000
			US 5933927 A	10-08-1999
			WO 9903369 A1	28-01-1999
