

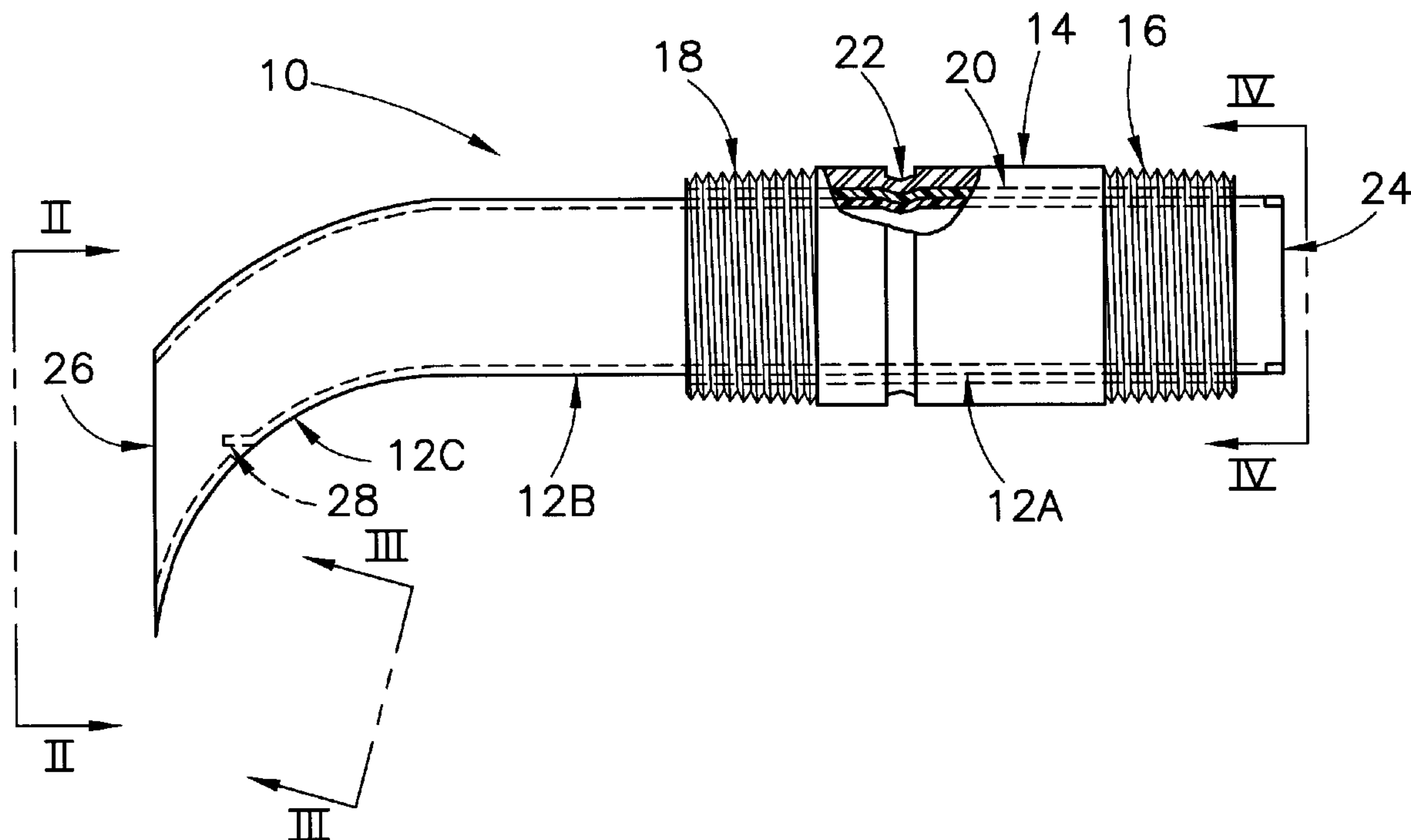

(22) Date de dépôt/Filing Date: 1998/05/28
 (41) Mise à la disp. pub./Open to Public Insp.: 1998/11/29
 (45) Date de délivrance/Issue Date: 2008/01/22
 (30) Priorités/Priorities: 1997/05/29 (US08/865,051);
 1997/05/29 (US08/865,006)

(51) Cl.Int./Int.Cl. *F24H 9/00* (2006.01),
F24H 9/12 (2006.01)
 (72) Inventeur/Inventor:
 LANNES, ERIC M., US
 (73) Propriétaire/Owner:
 LANNES, ERIC M., US
 (74) Agent: GOUDREAU GAGE DUBUC

(54) Titre : RACCORD D'ADMISSION POUR CHAUFFE-EAU
 (54) Title: INLET FOR A WATER HEATER



(57) **Abrégé/Abstract:**

An inlet for a water heater is provided for delivering water into a water heater through a port. The inlet includes a conduit having a distal portion that extends downwardly toward a bottom of the water heater. The inlet includes means for deflecting the water flow through openings in the inlet in order to reduce or remove temperature gradients in the water. A water heater assembly including such an inlet is also described; its water inflow extends toward a bottom of the water heater and the inlet includes means for deflecting the water flow in order to reduce the temperature gradients.

Abstract

An inlet for a water heater is provided for delivering water into a water heater through a port. The inlet includes a conduit having a distal portion that extends downwardly toward a bottom of the water heater. The inlet includes means for deflecting the water flow through openings in the inlet in order to reduce or remove temperature gradients in the water. A water heater assembly including such an inlet is also described; its water inflow extends toward a bottom of the water heater and the inlet includes means for deflecting the water flow in order to reduce the temperature gradients.

INLET FOR A WATER HEATER

Background of the Invention

This invention relates to an inlet for a water heater, which inlet serves to reduce
5 the generation of temperature gradients within the water heater. It is preferably
connected into the water heater tank through the top or a side wall.

Field of the Invention

The generation of temperature gradients in water heaters above the desired outlet
10 temperature represents a serious problem. Heating of water promotes the precipitation
of sediment, and excessive temperature gradients tend to accelerate sediment precipitation.
Accumulated sediment tends to harden, forming a scale on various tank surfaces, which
reduces water heater efficiency and, in many cases, can lead to failure.

Also, excessive temperature gradients tend to cause excessive temperature
15 fluctuations. Such fluctuations bring about undue fatigue of the water heater tank and can
reduce water heater longevity.

Furthermore, excessive temperature gradients within the water heater's tank can
tend to reduce the draw-off ability of the water heater and can decrease the water heater's
response time. Both of these conditions compromise water heater efficiency.

Objects of the Invention

20 It is an object of the invention to provide an inlet adapted to reduce the generation
of temperature gradients that tend to develop in water heater tanks.

It is another object of the invention to provide an inlet adapted to increase water
heater efficiency.

25 It is yet another object of the invention to provide a cost effective inlet that is easy
to install at the top or side of a water heater.

Other objects of the invention will become clear from the drawings and descriptions that follow.

Brief Description of the Drawings

5 Fig. 1 is a side view of an embodiment of a top inlet according to this invention.

Fig. 2 is an end view of the top inlet shown in Fig. 1.

Fig. 3 is a side view of a portion of the top inlet shown in Fig. 1.

Fig. 4 is a cross-sectional side view of a detail of the top inlet shown in Fig. 3.

10 Fig. 5 is a side view of another embodiment of a top inlet according to this invention.

Fig. 6 is a side view of an embodiment of a water heater comprising the top inlet shown in Fig. 1 or Fig. 5.

Fig. 7 is a side view of an embodiment of a side inlet according to this invention.

Fig. 8 is a front end view of a portion of the side inlet shown in Fig. 7.

15 Fig. 9 is a rear end view of a portion of the side inlet shown in Fig. 7.

Fig. 10 is a rear end view of another portion of the side inlet shown in Fig. 7.

Fig. 11 is a cross-sectional side view of a detail of the side inlet shown in Fig. 9.

20 Fig. 12 is a side view of an embodiment of a water heater comprising the side inlet shown in Fig. 7.

Summary of the Invention

25 This invention relates to an inlet adapted for delivering water into a water heater tank through a top port. The inlet includes a conduit having a proximal portion with a flow opening for water flow into the inlet from a water source. The conduit extends from the proximal portion downwardly to a distal end portion, which includes a flow opening for water flow from the conduit into the tank. The conduit defines a longitudinal flow

passage. A plurality of wall openings is provided for radial flow from the flow passage. Means such as a deflector is provided within the conduit adjacent to each of the wall openings. They extend into the flow passage for deflecting at least a portion of the water flow radially outwardly through the wall openings.

5 Upon installation of the inlet into the water heater tank, the proximal portion of the conduit extends through the tank's top port and the distal end portion extends downward toward a bottom surface of the tank. As water flows into the tank, the wall openings and the deflecting means co-act to reduce the generation of temperature gradients in the tank.

10 This invention also relates to a water heater that is capable of reducing the generation of such temperature gradients. It includes an inlet conduit, as described, as well as a fitting for engaging the inlet conduit to the tank's top port.

 Another embodiment relates to an inlet delivering water into a water heater tank through a side port. The inlet includes a conduit having a proximal portion with a flow opening for water flow into the inlet from a water source. The conduit also includes an
15 intermediate portion that extends from the proximal portion to a distal portion, which includes a flow opening for water flow from the conduit into the tank. The proximal, intermediate and distal portions together define a flow passage. Means such as a deflector is provided within the distal portion of the conduit. It extends into the flow
20 passage for deflecting the water flow.

 Upon installation of the inlet into the water heater tank, the proximal portion of the conduit extends through the tank's side port, the intermediate portion extends toward an interior region of the tank and the distal portion extends downward toward a bottom of the tank. As water flows into the tank, the distal portion of the conduit and the
25 deflecting means co-act to reduce the generation of temperature gradients in the tank.

This invention also relates to a water heater that is adapted to reduce the generation of such temperature gradients. It includes an inlet conduit, as described, as well as a fitting for engaging the inlet conduit to the tank's side port. The water heater is capable of reduced temperature gradients in accordance with an object of this invention.

5

Detailed Description of the Invention

The following description is intended to refer to specific embodiments of the invention illustrated in the drawings. While a specific configuration has been selected for illustration, the flow pattern of incoming water is highly effective with various modifications. This description is not intended to define or limit the scope of the invention, which is defined separately in the claims that follow. Also, it will be appreciated that the drawings are not necessarily to scale and are merely provided for the purpose of illustration.

Generally speaking, the invention relates to an inlet adapted for delivering cold water into the storage tank of a water heater. Although the invention has been discovered to be highly beneficial for use in gas-fired water heaters that are intended for commercial use, the inlet is highly effective in electric, oil-fired and any other type of residential or commercial water heater.

The inlet includes a conduit that is sized and shaped to be installed through the top port of a water heater. It has a proximal portion that is to be connected to the tank's top port by means of a fitting. Extending from the proximal portion is a distal portion that terminates at a flow opening for introducing water from the conduit and into the tank's interior.

Upon installation of the inlet into the water heater's tank, the proximal portion of the inlet conduit preferably extends through the tank's top port. The conduit extends

25

downwardly from the proximal portion, preferably along a vertical axis. The distal portion preferably extends downwardly toward a bottom of the tank and terminates at an end opening that is most preferably positioned adjacent to the tank's bottom surface.

5 The inlet conduit is preferably provided with a substantially tubular shape with a substantially constant cross-sectional area for the flow passage that extends through the proximal and distal portions. The flow opening is optionally reduced or constricted. The preferred inlet conduit defines a substantially continuous flow passageway extending from a proximal end outside the tank to a distal end oriented toward the tank's bottom.

10 A plurality of wall openings are provided in the wall of the conduit at locations between the proximal and distal ends of the conduit, preferably closer to the distal end. The wall openings provide passages for flow from the longitudinal flow passageway in the conduit radially outwardly into the tank's interior.

15 A means, such as one or more flow deflectors or an equivalent structure, is connected within the inlet conduit adjacent to each of the wall openings. The means is positioned to extend into the water flow path in order to deflect the water flow as it travels through the inlet conduit radially outwardly through an adjacent wall opening toward the tank's interior. In a preferred embodiment, the means for deflecting the water flow includes an angled surface positioned adjacent to the conduit's wall and extending within the conduit into the water flow path. The means can be any deflector or element
20 that redirects the water flow as it passes through the conduit toward the tank's interior. Most preferably, it takes the form of a tab that is connected in the conduit's wall and that extends toward the central axis of the conduit. Such a preferred tab is located adjacent to a hole in the conduit's wall, perhaps a hole created by forming the tab. Most preferably such a tab is positioned just downstream from the wall opening. Although the
25 means for deflecting the water flow is preferably integral with the inlet conduit or the

wall thereof, it can be formed from a separate component that is attached to the conduit by a fastener, snap-in or press-fit engagement, weld, threads, or any other known or equivalent fastening means.

5 A threaded fitting is preferably used to connect the inlet conduit to the tank's top port. In a preferred embodiment, a threaded fitting is engaged over the proximal portion of the inlet conduit so that it can be threaded into a spud attached to the water heater tank's top. The fitting is preferably engaged to the inlet conduit so that longitudinal movement of the inlet conduit through the fitting is prevented. In a preferred structure, this is accomplished by forming a ring-type groove in the outer surface of the fitting in order to create a radially inwardly extending surface within the fitting that can capture the conduit. It is this ring groove that prevents such longitudinal movement.

10 Although the deflecting means and wall openings are preferably positioned along the conduit so that the orientation of the conduit about its longitudinal axis is not critical for optimal performance, the ring groove can be adapted to permit rotation of the inlet conduit even after the inlet is installed in the water heater. Accordingly, a means is preferably provided for rotating the conduit in the fitting to adjust the conduit's orientation. The means may include a recess, such as a slot for example, or any surface positioned near or at the proximal end of the conduit. Engagement of such a surface facilitates the conduit's rotation after the fitting is threaded into the spud. A visual indicator is preferably provided to indicate the orientation of the conduit from outside of the tank.

20 In an optional feature of the invention, the proximal end of the inlet conduit extends outwardly beyond the proximal end of the fitting. This feature provides unobstructed access to the proximal end of the conduit for rotational adjustment. Also, when a source of cold water is connected to the proximal end of the fitting to make the

25

necessary connection, the proximal end of the inlet conduit can extend outwardly beyond the end of the fitting. It has been discovered that water flow from the source into the inlet is directed toward the central interior region of the inlet. Such flow reduces the wear and erosion that can otherwise be caused when flowing water directly impacts
5 against the fitting. Instead, a buffer of slow-moving water is trapped adjacent to the fitting's end. Such an optional feature may be especially desirable when dielectric insulation is positioned between the fitting and the conduit. The optional extension of the conduit beyond the fitting's end prevents accelerated erosion of the dielectric insulation.

The invention further relates to an inlet adapted for delivering cold water through
10 a side port. Although the invention has been discovered to be highly beneficial for use in gas-fired water heaters that are intended for commercial use, the inlet is highly effective in electric, oil-fired and any other residential or commercial water heaters.

The inlet has a proximal portion that is to be connected to the tank's side port by means of a fitting. Extending from the proximal portion is an intermediate portion that
15 is intended to be positioned within the tank so that it extends from the side port and preferably toward a central region of the tank's interior, most preferably toward the central, vertical axis of the water heater. From the end of the intermediate portion extends a distal portion that terminates at a flow opening for introducing water from the conduit and into the tank's interior.

20 Upon installation of the inlet into the water heater's tank, the proximal portion of the inlet conduit preferably extends through the tank's side port. The intermediate portion preferably extends toward the tank's interior. Most preferably, the intermediate portion is horizontal or near horizontal so that it extends toward the tank's interior in a plane that is substantially parallel to the tank's bottom. The distal portion preferably extends
25 downwardly toward a bottom of the tank. From the downstream end of the intermediate

portion, the conduit's distal portion most preferably curves downwardly toward the tank's bottom surface. Such curvature is preferably gradual so that the conduit can easily be formed by a bending process, if desired.

5 The flow opening through which water flows from the inlet is positioned at the downstream end of the distal portion. The opening is preferably oriented at some angle to the axis of the distal portion. In other words, the flow opening preferably lies in a plane that is at an angle to the distal portion's axis; most preferably an acute angle such that the opening generally faces the central region of the tank's interior.

10 The inlet conduit is preferably provided with a substantially tubular shape with a substantially constant cross-sectional area for the flow passage that extends through the proximal, intermediate and distal portions and through the flow opening. The preferred inlet conduit defines a substantially continuous flow passageway extending from a proximal end outside the tank to a distal end oriented toward the tank's bottom central region.

15 A means, such as one or more flow deflectors or an equivalent structure, is connected adjacent to and within the distal portion of the inlet conduit and is positioned to extend into the water flow path in order to deflect the water flow as it travels through the inlet conduit toward the tank's interior. In a preferred embodiment, the means for deflecting the water flow includes an angled surface positioned adjacent to the distal portion's wall and extending within the distal portion into the water flow path. The means can be any deflector or element that redirects or disturbs the water flow as it passes through the distal portion toward the tank's interior. Most preferably, it takes the form of a tab that is connected in the distal portion's wall and that extends toward the central axis of the conduit. Although such a preferred tab may be located adjacent to a hole in the distal portion's wall, perhaps a hole created by forming the tab, it is not

20

25

necessary for such a hole to exist and the conduit's end opening may be the only opening. Also, although the means for deflecting the water flow is preferably integral with the inlet conduit or the wall thereof, it can be formed from a separate component that is attached to the distal portion by a fastener, snap-in or press-fit engagement, weld, threads, or any
5 other known or equivalent fastening means.

A threaded fitting is preferably used to connect the inlet conduit to the tank's side port. In a preferred embodiment, a threaded fitting is engaged over the proximal portion of the inlet conduit so that it can be threaded into a spud attached to the water heater tank's wall. The fitting is preferably engaged to the inlet conduit so that longitudinal
10 movement of the inlet conduit through the fitting is prevented although rotational movement of the inlet conduit about the conduit's axis is permitted. In a preferred structure, this is accomplished by forming a ring-type groove in the outer surface of the fitting in order to create a radially inwardly extending surface within the fitting that can capture the conduit. It is this ring groove that prevents such longitudinal movement while
15 permitting rotational movement.

Such rotational movement of the conduit in the fitting confers a significant benefit because the downward orientation of the conduit's distal portion should be maintained for optimal performance of the inlet and because this orientation will change as the fitting is threaded into the tank. Accordingly, a means is preferably provided for rotating the
20 conduit in the fitting to adjust the orientation of the distal portion. The means may include a recess, such as a slot for example, or any surface positioned near or at the proximal end of the conduit. Engagement of such a surface facilitates the conduit's rotation after the fitting is threaded into the spud. A visual indicator is preferably provided to indicate the orientation of the conduit from outside of the tank.

25 In another preferred feature of the invention, the proximal end of the inlet conduit

extends outwardly beyond the proximal end of the fitting. This preferred feature provides unobstructed access to the proximal end of the conduit for rotational adjustment. Also, when a source of cold water is connected to the proximal end of the fitting to make the necessary connection, the proximal end of the inlet conduit extends outwardly beyond the
5 end of the fitting. It has been discovered that water flow from the source into the inlet is directed toward the central interior region of the inlet. Such flow reduces the wear and erosion that can otherwise be caused when flowing water directly impacts against the fitting. Instead, a buffer of slow-moving water is trapped adjacent to the fitting's end. Such a preferred feature is especially desirable when dielectric insulation is positioned
10 between the fitting and the conduit. The preferred extension of the conduit beyond the fitting's end prevents accelerated erosion of the dielectric insulation.

Referring to Figs. 1-4, a preferred embodiment of an inlet according to this invention, designated by the numeral "10", will now be described. Fig. 1 shows a side view of inlet 10 having an inlet conduit 12 with a proximal portion 12A and a distal
15 portion 12B that extends to the end of the inlet conduit. Together, portions 12A and 12B define a continuous flow passageway with a tubular cross-section, although other cross-sections are contemplated as well. In this embodiment, portions 12A and 12B share the same axis, and portion 12B is substantially an extension of portion 12A. The inlet conduit can be formed from plastic or metal, as desired.

Engaging the proximal portion 12A of the conduit is a fitting 14 that is preferably
20 formed from a metal such as steel. Fitting 14 includes male pipe threads 16 and 18 at each end. Pipe thread 16 is used for water-tight connection to a source of cold inlet water (not shown). Pipe thread 18 is intended for threaded engagement of fitting 14 into the spud of a water heater's storage tank (not shown in Fig. 1). Within fitting 14, and
25 captured between fitting 14 and the inlet conduit, is a dielectric insulator 20, preferably

in the form of an insulating polymeric tube. Dielectric insulator **20** provides dielectric isolation between the metallic fitting **14** and the inlet conduit.

5 A ring-type groove **22** is formed in the outer surface of fitting **14** by known manufacturing methods. The groove **22** provides the interior surface of fitting **14** with a radially inwardly extending surface that captures dielectric insulator **20** as well as proximal portion **12A** of the inlet conduit. A ring groove is preferably used to serve this purpose because it prevents longitudinal movement of the inlet conduit through fitting **14**, along its axis. At the same time, groove **22** can be adapted to permit rotational movement of the inlet conduit with respect to the fitting **14** so that their relative positions can be adjusted, if desired. A proximal end **24** of the inlet conduit optionally extends outwardly beyond the proximal end of the fitting **14** in the preferred embodiment for the reasons set forth in the general description of the invention. Although not shown, the proximal end of the inlet conduit preferably includes a pair of slots, or some other equivalent recess or surface, in order to facilitate rotation of the conduit within the fitting **14**. A tool can be positioned across such slots and rotated until a desired position is obtained, if necessary. The slots themselves, or a separate indicator such as an arrow or other indicia, can act to signify the orientation of the conduit with respect to the fitting and tank.

20 At the other end of the inlet conduit, an opening **26** is provided at the downstream end of distal portion **12B**. In this preferred embodiment, opening **26** occupies a plane that is substantially horizontal and normal to the longitudinal axis of portions **12A** and **12B**. The opening **26** extends entirely across the distal portion **12B** and, when viewed from the bottom (Fig. 2), it has a cross-sectional area as large as the cross-sectional area of the flow passageway through the inlet conduit.

25 One possible form of a deflector or deflecting means is designated with the

numeral "28", although many other possible forms and configurations are contemplated. In this embodiment, a plurality of deflectors or tabs 28 are integrally connected to the interior surface along distal portion 12B of the inlet conduit. Tabs 28 extend inwardly toward the central region of the flow passageway in order to deflect the water flow through adjacent wall openings 30 that are located just upstream of corresponding deflectors. The tabs 28 cooperate with the inlet conduit to reduce the generation of temperature gradients within the water heater.

Further details of a preferred tab 28 will now be described with reference to Figs. 2, 3 and 4. Tab 28, in this embodiment, takes the form of an integral, semi-circular tab that is cut into the wall of the inlet conduit and bent along a fold line 29 (Fig. 3) in a direction toward the conduit's central axis. In so doing, the corresponding opening 30 is created in the conduit's wall adjacent to and upstream of tab 28. It is important to note that tab 28 can be formed in a wide variety of manners. In fact, deflector 28 can be formed as an entirely separate component that can be attached to, or mounted within, the distal portion 12B of the inlet conduit.

As shown in Fig. 4, which provides a cross-sectional view of a portion of a wall 32 in the distal portion 12B, the tab 28 extends into the flow path at an angle such as angle " α ". The distance it extends into the flow path is designated by the letter "D" in Fig. 4, and the size of the gap or opening 30 adjacent to the tab 28 is indicated by the letter "G". Angle α is preferably an acute angle in order to best deflect the water flow out through the wall openings.

Although only one deflector means arrangement is illustrated in the embodiment shown in the Figures, it is of course contemplated that a wide variety of arrangements can be used and that deflecting means can be positioned in a variety of locations and orientations.

Referring again to Fig. 1, the preferred embodiment of inlet **10** includes a series of tabs **28** positioned in four planes separated along the length of distal portion **12B**. Three tabs **28** are preferably provided in each of the four planes. Referring to Fig. 2, deflectors **28** extend inwardly and upwardly toward the central axis of the longitudinal flow passageway. In this embodiment, tabs **28** extend inwardly from the wall **32** of inlet conduit **12** from its inside diameter **ID**. Shown in dotted lines is a central region **C** of unobstructed flow through the plane of tabs **28**. Central region **C** can vary in diameter from zero or near zero to a diameter corresponding to the inside diameter of the inlet. However, central region **C** is preferably limited in diameter so that significant flow is directed through the wall openings. Most preferably, the cross-section area of central region **C** is substantially less than the cross-sectional area of inside diameter **ID**. For example, each tab **28** most preferably blocks between about 10% and 50% of the flow path, although smaller and larger tabs are contemplated as well.

In operation, as water flows downwardly through the flow passageway, a portion of the water flow impinges against tabs **28** and is swept radially outwardly in the general direction indicated by the arrows in Figs. 1 and 4. The rest of the water flow that remains in the flow passageway exits inlet conduit **12** through end opening **26** toward the bottom of the tank. Accordingly, water flows out through each of the wall openings **30** (by action of the adjacent tabs **28**) and through end opening **26**. This preferred flow pattern is capable of reducing the generation of temperature gradients within the water heater's tank.

Referring now to Fig. 3, each tab **28** has a width **W** and a height **H**, which also corresponds to the dimensions of the adjacent wall opening **30** in this embodiment. Together, width **W** and height **H** define the surface area of the deflector, which can be adjusted depending on factors such as the number of deflectors used, the relative position

of the deflectors, the inside diameter **ID** of the inlet conduit **12** (Fig. 2), the capacity and diameter of the water heater's tank, and the position of the deflector along the length of inlet conduit **12**.

Inlet conduit **12** is especially well adapted for use in commercial water heaters and, accordingly, may have an inside diameter as large as about 1 ¼" or larger. For this reason, tabs **28** should be large enough to "pull" or redirect a significant portion of the water flow out from the flow passageway. In order to encourage such flow, inlet **12** is optionally provided with a constriction such as the plug **13** shown in Fig. 5 in order to form a reduced flow opening **15** for flow into the tank. Such a reduced opening increases the pressure in the inlet conduit **12** to encourage maximum flow through tabs **28**.

Referring now to Fig. 6, a portion of a water heater **40** is illustrated with an inlet according to this invention as a component thereof. Water heater **40** includes an inlet spud **42** with female pipe threads (not shown) positioned on a top surface **41**. Male pipe threads **18** of fitting **14** are threaded into spud **42** in the usual manner until inlet **10** is sealingly engaged to the water heater **40**. In order to install inlet **10**, a pipe wrench or other tool can be used to rotate fitting **14** with respect to spud **42** to engage the threads. When the desired water-tight seal is created between the fitting and the spud, the orientation of the inlet conduit can then be adjusted (if necessary). Thereafter, the source of cold inlet water (not shown) can be connected to the male threads **16** on the proximal end portion of fitting **14**. The inlet is then ready for use in operation.

Referring to Figs. 7-11, a preferred embodiment of an inlet according to this invention, designated by the numeral "**10**", will now be described. Fig. 7 shows a side view of inlet **10** having an inlet conduit with a proximal portion **12A**, an intermediate portion **12B** extending from the downstream end of the proximal portion, and a distal portion **12C** that extends from the downstream end of the intermediate portion **12B** to the

end of the inlet conduit. Together, portions **12A**, **12B** and **12C** define a continuous flow passageway with a tubular cross-section, although other cross-sections are contemplated as well. In this embodiment, portions **12A** and **12B** share the same axis, and portion **12B** is substantially an extension of portion **12A**. The axis of portion **12C** curves downwardly from that of portions **12A** and **12B**. The inlet conduit can be formed from plastic or metal, as desired.

Engaging the proximal portion **12A** of the conduit is a fitting **14** that is preferably formed from a metal such as steel. Fitting **14** includes male pipe threads **16** and **18** at each end. Pipe thread **16** is used for water-tight connection to a source of cold inlet water (not shown). Pipe thread **18** is intended for threaded engagement of fitting **14** into the spud of a water heater's storage tank (not shown in Fig. 7). Within fitting **14**, and captured between fitting **14** and the inlet conduit, is a dielectric insulator **20**, preferably in the form of an insulating polymeric tube. Dielectric insulator **20** provides dielectric isolation between the metallic fitting **14** and the inlet conduit.

A ring-type groove **22** is formed in the outer surface of fitting **14** by known manufacturing methods. The groove **22** provides the interior surface of fitting **14** with a radially inwardly extending surface that captures dielectric insulator **20** as well as proximal portion **12A** of the inlet conduit. A ring groove is preferably used to serve this purpose because it prevents longitudinal movement of the inlet conduit through fitting **14**, along its axis. At the same time, groove **22** permits rotational movement of the inlet conduit with respect to the fitting **14** so that their relative positions can be adjusted. A proximal end **24** of the inlet conduit extends outwardly beyond the proximal end of the fitting **14** in the preferred embodiment for the reasons set forth in the general description of the invention.

At the other end of the inlet conduit, an opening **26** is provided at the downstream

end of distal portion **12C**. In this preferred embodiment, opening **26** occupies a plane that is substantially vertical and normal to the axis of portions **12A** and **12B**. It is most preferably oriented at an acute angle with respect to the axis of distal portion **12C**. The opening **26** extends entirely across the distal portion **12C** and, when viewed from the left in Fig. 7, it has a cross-sectional area at least as large as the cross-sectional area of the flow passageway through the inlet conduit.

One possible form of a deflector or deflecting means is designated with the numeral "**28**", although many other possible forms and configurations are contemplated. In this embodiment, deflector **28** is integrally connected to the interior, lower surface of distal portion **12C** of the inlet conduit. Deflector **28** extends inwardly toward the central region of the flow passageway in order to deflect the water flow and to cooperate with the inlet conduit to reduce the generation of temperature gradients within the water heater.

Further details of preferred deflector **28** will now be described with reference to Figs. 8, 9 and 11. Deflector **28**, in this embodiment, takes the form of an integral semi-circular tab that is cut into the wall of the inlet conduit and bent along a fold line **29** toward the conduit's central axis. In so doing, an opening **30** is created in the conduit's wall adjacent to and downstream of deflector **28**. Although such an opening may be preferred, it is important to note that deflector **28** can be formed in a wide variety of manners both with and without the formation of a hole in the conduit's wall. In fact, deflector **28** can be formed as an entirely separate component that can be attached to, or mounted within, the distal portion **12C** of the inlet conduit.

As shown in Fig. 11, which provides a cross-sectional view of a portion of a wall **34** in the distal portion **12C**, the deflector **28** extends at an angle such as angle " α " a predetermined distance into the flow path defined by the inlet conduit. This distance is

designated by the letter "D" in Fig. 11, and the size of the gap or opening **30** adjacent to the deflector **28** is indicated by the letter "G". Although only one deflector means is illustrated in the embodiment shown in the Figures, it is of course contemplated that more than one deflector can be used and that they can be positioned in a variety of locations and orientations.

5 Fig. 10 illustrates a preferred embodiment of the proximal end of the inlet conduit. It preferably includes a pair of slots **32**, or some other equivalent recess or surface, in order to facilitate rotation of the conduit within the fitting **14**. In this embodiment, a tool can be positioned across slots **32** and rotated until the distal portion **12C** of the inlet
10 conduit is facing in the optimal direction, which is toward a bottom region of the water heater tank. The slots **32** themselves, or a separate indicator such as an arrow or other indicia, act to signify the orientation of the conduit with respect to the fitting and tank.

Referring now to Fig. 12, a portion of a water heater **40** is illustrated with an inlet according to this invention as a component thereof. Water heater **40** includes an inlet
15 spud **42** with female pipe threads (not shown). Male pipe threads **18** of fitting **14** are threaded into spud **42** in the usual manner until inlet **10** is sealingly engaged to the water heater **40**. In order to install inlet **10**, a pipe wrench or other tool can be used to rotate fitting **14** with respect to spud **42** to engage the threads. When the desired water-tight seal is created between the fitting and the spud, the orientation of the inlet conduit can
20 then be adjusted utilizing the slots **32** shown in Fig. 10 so that distal portion **12C** is directed toward the tank's bottom. Thereafter, the source of cold inlet water (not shown) can be connected to the male threads **16** on the proximal end portion of fitting **14**. The inlet is then ready for use in operation.

The following Examples illustrate significant benefits according to this invention.

25 The Examples are provided for illustrative purposes only, and they are not intended to

limit the invention in any way.

EXAMPLE 1

An inlet such as the one illustrated in Fig. 1 was constructed and tested in commercial water heaters heated by gas-fired burners. The inlet was tested in comparison to a conventional top inlet that comprised a dip tube connected to the tank spud. The relative inlet performances were measured in relation to so-called "stacking" or "build-up". The stacking effect is described in U.S. Patent No. 5,341,770.

In this test, each water heater was allowed to heat up to a predetermined storage tank temperature of 180°F. Immediately after the main burner turned off, water was drawn off at a rate of 5 gallons per minute. The draw continued until the heater's thermostat called for heat (the main burner turned on). This cycle was repeated continuously until the measured outlet water temperature did not vary by more than 1°F for three consecutive draws. The test results are summarized in the following Table 1.

Table 1

Water Heater Capacity (gallons)	Input (BTUs)	Max. Temp. (°F) (conventional inlet)	Temp. Gradient above 180°F (°F) (conventional inlet)	Max. Temp. (°F) (Fig. 1 inlet)	Temp. Gradient above 180°F (°F) (Fig. 1 inlet)	Decrease in Temp. Gradient (%)
100	88,000	200	20	196	16	20
100	250,000	206	26	198	18	31
80	250,000	204	24	194	14	42

The tests revealed that the temperature gradient resulting from stacking was reduced by replacing a conventional top inlet with the inlet embodiment shown in Fig. 1. The temperature gradient above the 180°F starting point was reduced by as much as

42%. Such reduced temperature stratification is expected to reduce lime precipitation, lengthen the life of the water heater, and reduce or even eliminate the need for periodic cleaning to remove precipitated sediment.

EXAMPLE 2

5 An inlet such as the one illustrated in Fig. 1 was tested in commercial storage-type water heaters. The inlet was tested in comparison to a conventional top inlet, as in Example 1, to measure relative inlet performance in relation to so-called "draw-off ability", which is the ability of the storage water heater to deliver as much water as possible before the water's outlet temperature drops below a predetermined temperature.

10 In this test, each storage water heater was allowed to heat up to a predetermined storage tank temperature of 180°F. Once the burners turned off, they were disconnected from the water heater's thermostat. Water was then drawn off at a rate of about 5 gallons per minute and the temperature of the outlet water was measured along with its volume. The draw was continued until the outlet temperature dropped to about 150°F.

15 The test results are summarized in the following Table 2.

Table 2

Storage Water Heater Capacity (gallons)	Input (BTUs)	Drawn-off Volume (gallons) (conventional inlet)	Drawn-off Volume (gallons) (Fig. 1 inlet)	Volumetric Increase (%)
75	160,000	63	65	3
80	250,000	64	66	3
100	250,000	108	112	4
100	300,000	69	76	10

25 The tests revealed that the drawn-off volume before reaching 150°F was increased by replacing a conventional top inlet with the inlet embodiment shown in Fig. 1. The

drawn-off volume was increased by as much as 7 gallons (10%). Accordingly, more hot water is available during a draw and hot water is available for a longer period of time. Also, the increase in the drawn-off volume is expected to reduce temperature spikes at the delivery point and reduce the amount of work required for any external equipment such as booster water heaters.

EXAMPLE 3

An inlet such as the one illustrated in Fig. 1 was further tested in commercial water heaters in relation to so-called "burner on time". The amount of elapsed time was measured between burner shut-off and actuation of the thermostat to call for heat. The test was similar to the test described in Example 2 except, instead of measuring the water temperature, the time until the thermostat calls for heat was measured. The results of this test are summarized in Table 3.

Table 3

Water Heater Storage Capacity (gallons)	Input (BTUs)	Elapsed Time (seconds) (conventional inlet)	Elapsed Time (seconds) (Fig. 1 inlet)	Time Increase (%)
80	250,000	124	128	3
100	250,000	127	129	2
100	300,000	185	215	16
100	88,000	174	187	7

This test revealed that the amount of time in between the point when the burners are turned off and the point when the thermostat later calls for heat was significantly increased by replacing a conventional top inlet with the inlet embodiment shown in Fig. 1. The time was increased by as much as 30 seconds (16%), which is expected to reduce thermostat cycling and tank fatigue.

The exact reason for these significant benefits is not certain. Nevertheless, it is

speculated that the openings in the wall of the inlet conduit, together with the utilization of means for deflecting the water flow path through the openings, creates an extremely beneficial flow pattern. In the preferred configuration, it creates a number of streams that are directed out to the side of the conduit and downwardly at an angle as the water enters the interior of the tank. It is believed that such a flow pattern creates a thermal balance within the storage tank and enables a more rapid equilibrium between any stratified layers. Accordingly, the water temperature differential from side-to-side and from top-to-bottom within the tank is lower as compared to results from traditional open end or closed end inlet supply tubes. It is also speculated that the wall openings and deflecting means tend to distribute turbulent flow that may exist in the conduit into the tank while creating a vertical circular flow pattern. With such a pattern, the inlet encourages water circulation throughout the water heater's tank and reduces the temperature gradients that tend to be generated in such tanks.

Also, when used with a burner-heated system with higher input and perhaps multiple flue tubes, the inlet according to this invention reduces short cycling of the burner and causes it to fire for a longer period of time. This has been discovered to enable better polarization for the cathode, reduce the amount of stress at the weld between the flue(s) and the base, and reduce carbonate precipitation as a result of better thermal balance.

Many modifications to the disclosed embodiments are contemplated. For example, although the top inlet according to this invention confers many benefits when used in a gas-fired commercial water heater, it can be used in any residential water heater as well, heated by any available heat source. Also, the optional end constriction embodiment illustrated in Fig. 5 can be removed entirely or replaced with an alternative construction such as a plug that extends into the conduit, an inwardly bent wall portion of the conduit

itself, a twisted end portion of the conduit that defines a constricted outlet diameter, or a welded or otherwise attached component that extends the conduit and positions the constricted opening adjacent to the conduits distal end. In some circumstances it may even prove desirable to entirely close the conduit's end opening in order to direct all of the water flow radially outwardly through the wall openings.

The size and shape of the deflecting means, as well as their number, can vary widely. Although the shape illustrated in the Figures is preferred, it is believed that the surface area and angle of the preferred deflectors may be at least as effective as their shape. For example, a tab or deflector of small width **W** and large height **H** can be exchanged with a deflector of large width **W** and small height **H**. Also, a semicircular deflector with a particular surface area can be exchanged with a deflector having a different shape but a similar surface area, although surface area can be changed as well to suit a particular application. It is also contemplated that the preferred deflectors on the same conduit may differ from one another in terms of their size and/or shape.

The number of preferred deflectors that are positioned in the same plane can vary from a single deflector to 3 or 4 or more, limited only by the diameter and strength of the inlet conduit. The distance between adjacent planes may vary or remain constant if more than two planes of deflecting means are used. Also, the preferred deflectors can be provided in linear rows along the length of the inlet conduit as shown in Fig. 1, for example, or they can be staggered or helically arranged along the conduit's length. While deflectors such as tab **28** are a preferred form of deflecting means, any structure can be alternatively used so long as it is capable of deflecting water flow outwardly through openings in the inlet conduit.

EXAMPLE 4

An inlet such as the one illustrated in Fig. 7 was constructed and tested in

commercial water heaters heated by gas-fired burners. The inlet was tested in comparison to a conventional side inlet that comprised a nipple connected to the tank spuds. The relative inlet performances were measured in relation to so-called "stacking" or "build-up".

5 In this test, each water heater was allowed to heat up to a predetermined storage tank temperature of 180°F. Immediately after the main burner turned off, water was drawn off at a rate of 5 gallons per minute. The draw continued until the heater's thermostat called for heat (the main burner turned on). This cycle was repeated continuously until the measured outlet water temperature did not vary by more than 1°F for three consecutive draws. The test results are summarized in the following Table 4.

Table 4

Water Heater Capacity (gallons)	Input (BTUs)	Max. Temp. (°F) (conventional inlet)	Temp. Gradient above 180°F (°F) (conventional inlet)	Max. Temp. (°F) (Fig. 1 inlet)	Temp. Gradient above 180°F (°F) (Fig. 1 inlet)	Decrease in Temp. Gradient (%)
100	200,000	198	18	196	16	11
100	250,000	205	25	195	15	40
100	300,000	201	21	196	16	24

20 The tests revealed that the temperature gradient resulting from stacking was reduced by replacing a conventional side inlet with the inlet embodiment shown in Fig. 7. The temperature gradient above the 180°F starting point was reduced by as much as 40%.

EXAMPLE 5

25 An inlet such as the one illustrated in Fig. 7 was tested in commercial storage-type water heaters. The inlet was tested in comparison to a conventional side inlet, as in

Example 4, to measure relative inlet performance in relation to so-called "draw-off ability", which is the ability of the storage water heater to deliver as much water as possible before the water's outlet temperature drops below a predetermined temperature.

In this test, each storage water heater was allowed to heat up to a predetermined storage tank temperature of 180°F. Once the burners turned off, they were disconnected from the water heater's thermostat. Water was then drawn off at a rate of about 5 gallons per minute and the temperature of the outlet water was measured along with its volume. The draw was continued until the outlet temperature dropped to about 150°F. The test results are summarized in the following Table 5.

Table 5

Storage Water Heater Capacity (gallons)	Input (BTUs)	Drawn-off Volume (gallons) (conventional inlet)	Drawn-off Volume (gallons) (Fig. 1 inlet)	Volumetric Increase (gallons)
75	160,000	46	60	14
80	250,000	62	72	10
100	250,000	87	94	7
100	300,000	89	92	3

The tests revealed that the drawn-off volume before reaching 150°F was increased by replacing a conventional side inlet with the inlet embodiment shown in Fig. 7. The drawn-off volume was increased by as much as 14 gallons (30%).

EXAMPLE 6

An inlet such as the one illustrated in Fig. 7 was further tested in commercial water heaters in relation to so-called "burner on time". The amount of elapsed time was measured between burner shut-off and actuation of the thermostat to call for heat. The test was similar to the test described in Example 5 except, instead of measuring the water

temperature, the time until the thermostat calls for heat was measured. The results of this test are summarized in Table 6.

Table 6

Water Heater Storage Capacity (gallons)	Input (BTUs)	Elapsed Time (seconds) (conventional inlet)	Elapsed Time (seconds) (Fig. 1 inlet)	Time Increase (seconds)
75	160,000	71	75	4
80	250,000	125	126	1
100	250,000	171	192	21
100	300,000	343	403	60
75	300,000	429	443	14

This test revealed that the amount of time in between the point when the burners are turned off and the point when the thermostat later calls for heat was significantly increased by replacing a conventional side inlet with the inlet embodiment shown in Fig. 7. The time was increased by as much as 60 seconds (17%), which is expected to reduce thermostat cycling and tank fatigue.

The exact reason for these significant benefits is not certain. Nevertheless, it is speculated that the shape of the inlet conduit, together with the utilization of means for deflecting the water flow path, creates a beneficial flow pattern. It is similar to the flow pattern created when one places a finger or thumb over the end of a hose to modify the flow path. This so-called "hose spray effect" encourages water circulation throughout the water heater's tank. It also reduces the temperature gradients that tend to be generated in such tanks.

Although this invention has been described with reference to specific forms selected for illustration in the drawings, and with respect to various modifications thereof, it will be appreciated that many other variations may be made without departing from the

feature of reducing the generation of temperature gradients within a water heater tank. All such variations, including the substitution of equivalent elements or materials for those specifically shown and described, are within the spirit and scope of the invention as defined in the appended claims.

What is claimed is:

1. A side inlet connected for delivering water into a water heater tank through a side wall of said tank, adjacent a water tank bottom, said inlet comprising:

5 an inlet conduit comprising a proximal portion defining a flow opening for water flow into said inlet conduit, an intermediate conduit portion extending from said proximal portion and defining a flow passage for said water flow, and a distal conduit portion having an axis extending from said intermediate portion and provided with a flow opening for said water flow from said inlet conduit; and

10 deflecting means extending within said distal portion of said inlet conduit and extending into said water flow for deflecting said water flow;

15 wherein said intermediate portion of said inlet conduit extends toward an interior region of said tank, said distal portion of said inlet conduit being angled downwardly toward the bottom of said tank; said flow opening being oriented at an angle relative to an axis of said distal portion; said angle being an acute angle, such that said flow opening faces toward a central region of said tank; and said distal portion of said inlet conduit, said flow opening for said water flow forming said inlet conduit and said means for deflecting said water flow coacting, as said water flows into said tank, to modify said water flow so as to create a spray effect, promoting water circulation within said tank, reducing a generation of temperature gradients within said tank, increasing a draw-off capacity of said water heater, and reducing thermostat cycling and tank fatigue of said water heater.

25 2. The inlet defined in claim 1, wherein said intermediate portion of said inlet conduit extends substantially horizontally toward said interior region of said tank upon installation of said inlet.

3. The inlet defined in claim 1, wherein said distal portion of said inlet conduit curves downwardly from said intermediate portion of said inlet conduit toward said bottom of said tank upon installation of said inlet.

30

4. The inlet defined in claim 1, wherein said means for deflecting said water flow comprises a surface positioned substantially adjacent to and within a wall of said distal portion of said inlet conduit and extending at an angle from said wall toward said path of said water flow.

5

5. The inlet defined in claim 1, further comprising a fitting engaged over said proximal portion of said inlet conduit for forming a connection between said inlet conduit and said tank wherein said inlet conduit extends through said fitting.

10

6. The inlet defined in claim 5, wherein said fitting comprises means for engaging said proximal portion of said inlet conduit to prevent movement of said inlet conduit in a direction along an axis of said proximal portion yet permitting rotation of said inlet conduit about said axis of said proximal portion.

15

7. The inlet defined in claim 6, wherein said means for engaging comprises a radially inwardly extending surface positioned to engage an outer surface of said proximal portion of said inlet conduit.

20

8. The inlet defined in claim 6, further comprising means positioned adjacent to said proximal portion for rotating said inlet conduit about said axis of said proximal portion for adjustment of the orientation of said distal portion of said inlet conduit with respect to said fitting upon installation of said inlet.

25

9. The inlet defined in claim 8, wherein said means for rotating comprises a recess positioned at a proximal end portion of said inlet conduit.

10. The inlet defined in claim 5, wherein a proximal end portion of said inlet conduit extends outwardly beyond a proximal end portion of said fitting.

30

11. The inlet defined in claim 5, wherein a dielectric insulator is positioned between said fitting and said inlet conduit.

12. An inlet adapted for delivering water into a tank of a water heater through a port extending through a side wall of said tank, said inlet comprising:

5 an inlet conduit comprising a proximal portion adapted for connection into said port, an intermediate conduit portion extending from said proximal portion and extending toward an interior region of said tank, and a distal conduit portion extending from said intermediate portion and curved toward the bottom of said tank, said proximal portion, said intermediate portion and said distal conduit portion together defining a path for water flow, and said distal portion having an end opening for said
10 water flow from said inlet conduit and into said tank;

and a deflector extending from the wall of said distal conduit portion within said distal portion of said inlet conduit and into said path of said water flow; and

said distal conduit portion wall having an opening downstream of said deflector;

15 wherein said end opening defined by said distal portion of said inlet conduit is oriented at an angle to said axis of said distal portion; said angle is an acute angle such that said end opening faces toward a central region of said tank; and said distal portion of said inlet conduit, said end opening and said deflector coact with said water flow to modify said water flow so as to create a spray effect to promote water circulation within said tank, reduce a generation of temperature gradients within said tank, increase
20 a draw-off capacity of said water heater and reduce thermostat cycling and tank fatigue of said water heater.

13. The inlet defined in claim 12, wherein said intermediate portion of said inlet conduit is positionable so that its axis extends in a substantially horizontal
25 direction from said proximal portion of said inlet conduit toward said interior region of said tank.

14. The inlet defined in claim 12, wherein said distal portion of said inlet conduit is positionable so that its axis curves downwardly from said intermediate
30 portion of said inlet conduit toward said bottom of said tank.

15. The inlet defined in claim 12, wherein said deflector comprises a surface positioned substantially adjacent to and within a wall of said distal portion of said inlet conduit and extending at an angle from said wall toward said path of said water flow.

5 16. The inlet defined in claim 12, further comprising a fitting engaged over said proximal portion of said inlet conduit and adapted for connecting said inlet conduit to said tank.

10 17. The inlet defined in claim 16, wherein said fitting comprises a radially inwardly extending surface positioned for engaging said inlet conduit to prevent movement of said inlet conduit in a direction along an axis of said proximal portion of said inlet conduit yet permitting rotation of said inlet conduit about said axis of said proximal portion.

15 18. The inlet defined in claim 17, further comprising a recess positioned adjacent to said proximal portion to facilitate rotation of said inlet conduit about said axis of said proximal portion of said inlet conduit to adjust the orientation of said distal portion and said end opening of said inlet conduit with respect to said fitting.

20 19. The inlet defined in claim 16, wherein a proximal end portion of said inlet conduit extends outwardly beyond a proximal end portion of said fitting.

25 20. The inlet defined in claim 16, wherein a dielectric insulator is positioned between said fitting and said inlet conduit.

21. A water heater adapted to reduce a generation of temperature gradients that tend to occur with said water heater, said water heater comprising:

a tank having a port defined in a side wall thereof;

30 an inlet conduit connected for water flow into said tank, said inlet conduit comprising a proximal conduit portion, an intermediate conduit portion extending from said proximal conduit portion and toward an interior region of said tank, and a distal

conduit portion extending from said intermediate conduit portion toward a bottom of said tank, said proximal portion, said intermediate portion and said distal portion together defining a path for said water flow, and said distal portion defining an end opening for said water flow from said inlet conduit and into said tank;

5 a deflector extending from the wall of said distal conduit portion within said inlet conduit into said path of said water flow; said distal conduit portion wall having an opening downstream of said deflectors; and

a fitting engaging said proximal portion of said inlet conduit and connected to said port defined in said side wall of said tank;

10 wherein said flow opening is oriented at an acute angle to the axis of said distal portion, and said distal portion of said inlet conduit, said flow opening for said water flow forming said inlet conduit and said deflector coact to modify said flow pattern creating a spray effect that promotes water circulation within said tank, reduces the generation of said temperature gradients within said tank, increases draw-off capacity
15 of said water heater and reduces the thermostat cycling and tank fatigue of said water heater.

22. The water heater defined in claim 21, wherein said intermediate portion of said inlet conduit extends in a substantially horizontal direction from said proximal
20 portion toward said interior region of said tank.

23. The water heater defined in claim 21, wherein said distal portion of said inlet conduit curves downwardly from said intermediate portion toward said bottom of said tank.

25 24. The water heater defined in claim 21, wherein said inlet conduit is substantially tubular along said proximal portion, said intermediate portion and said distal portion.

25. The water heater defined in claim 21, wherein said deflector comprises a surface positioned adjacent to a wall of said distal portion and extending at an angle from said wall into said path of said water flow.

5 26. The water heater defined in claim 21, wherein said fitting engages said inlet conduit to prevent movement in a direction along an axis of said proximal portion of said inlet conduit while permitting rotation of said inlet conduit about said axis.

10 27. The water heater defined in claim 26, further comprising a surface positioned adjacent to said proximal portion of said inlet conduit to facilitate rotation of said inlet conduit about said axis and adjustment of the orientation of said distal portion toward said bottom of said tank.

15 28. The water heater defined in claim 21, wherein a proximal end portion of said inlet conduit extends outwardly beyond a proximal end portion of said fitting.

29. The water heater defined in claim 21, said water heater further comprising a dielectric insulator positioned between said fitting and said inlet conduit.

20 30. An inlet adapted for delivering water into a tank of a water heater through a port defined in a side wall of said tank, said inlet comprising:

an inlet conduit comprising a proximal portion adapted for connection to said port, an intermediate portion extending from said proximal portion and positionable toward an interior region of said tank, and a distal portion extending from said intermediate portion and positionable toward a bottom of said tank, said proximal portion, said intermediate portion and said distal portion together defining a path for water flow, and said distal portion defining an end opening for said water flow from said inlet conduit and into said tank; and

30 a deflector extending within said distal portion of said inlet conduit and extending into said path of said water flow;

wherein said distal portion of said inlet conduit and said deflector coact with said water flow to reduce the generation of temperature gradients within said tank; and said intermediate portion of said inlet conduit is positionable so that its axis extends in a substantially horizontal direction from said proximal portion of said inlet conduit toward said interior region of said tank, and so that its axis curves downwardly from said intermediate portion of said inlet conduit toward said bottom of said tank, and wherein said end opening defined by said distal portion of said inlet conduit is oriented at an acute angle to said axis of said distal portion such that said end opening faces toward a central region of said tank.

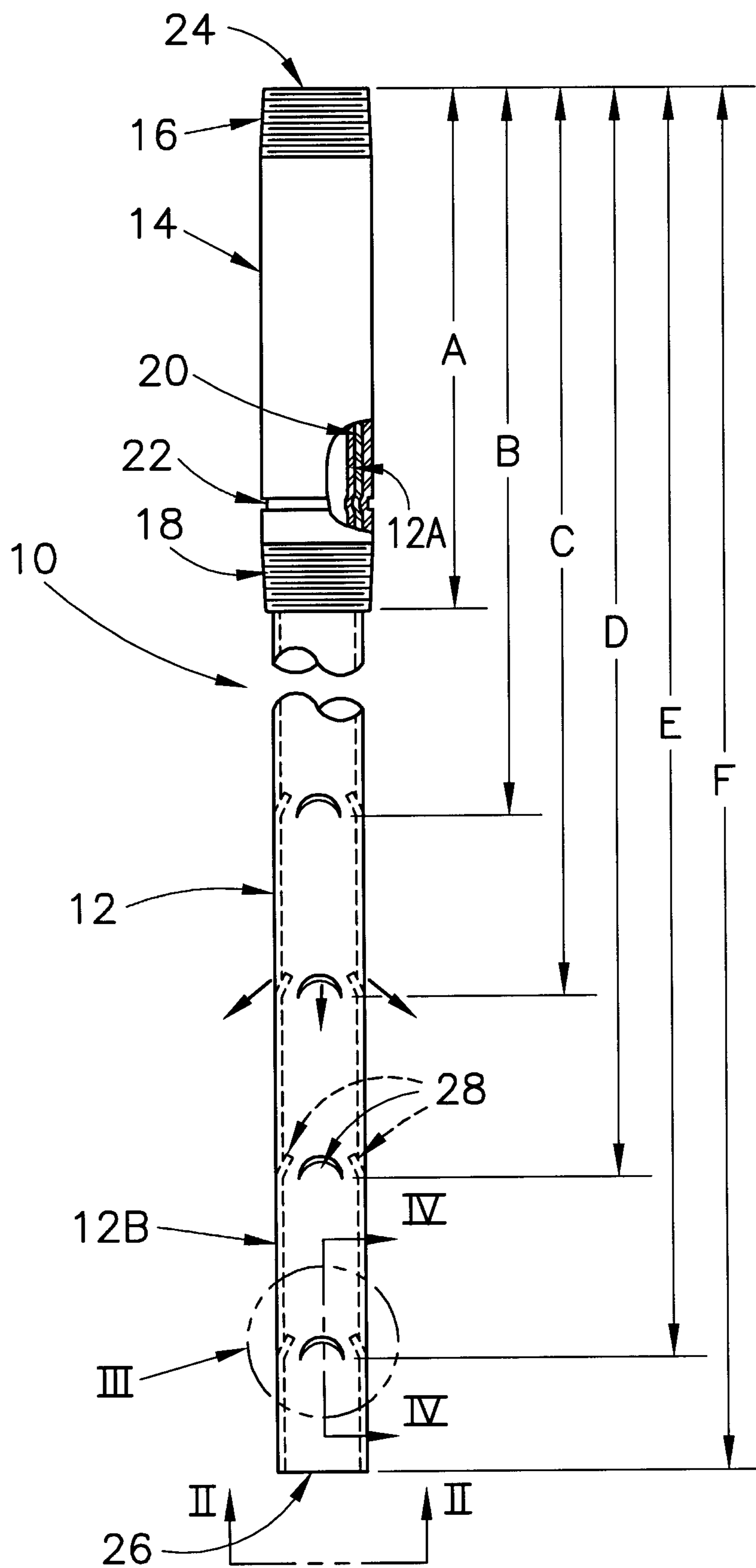

Fig. 1

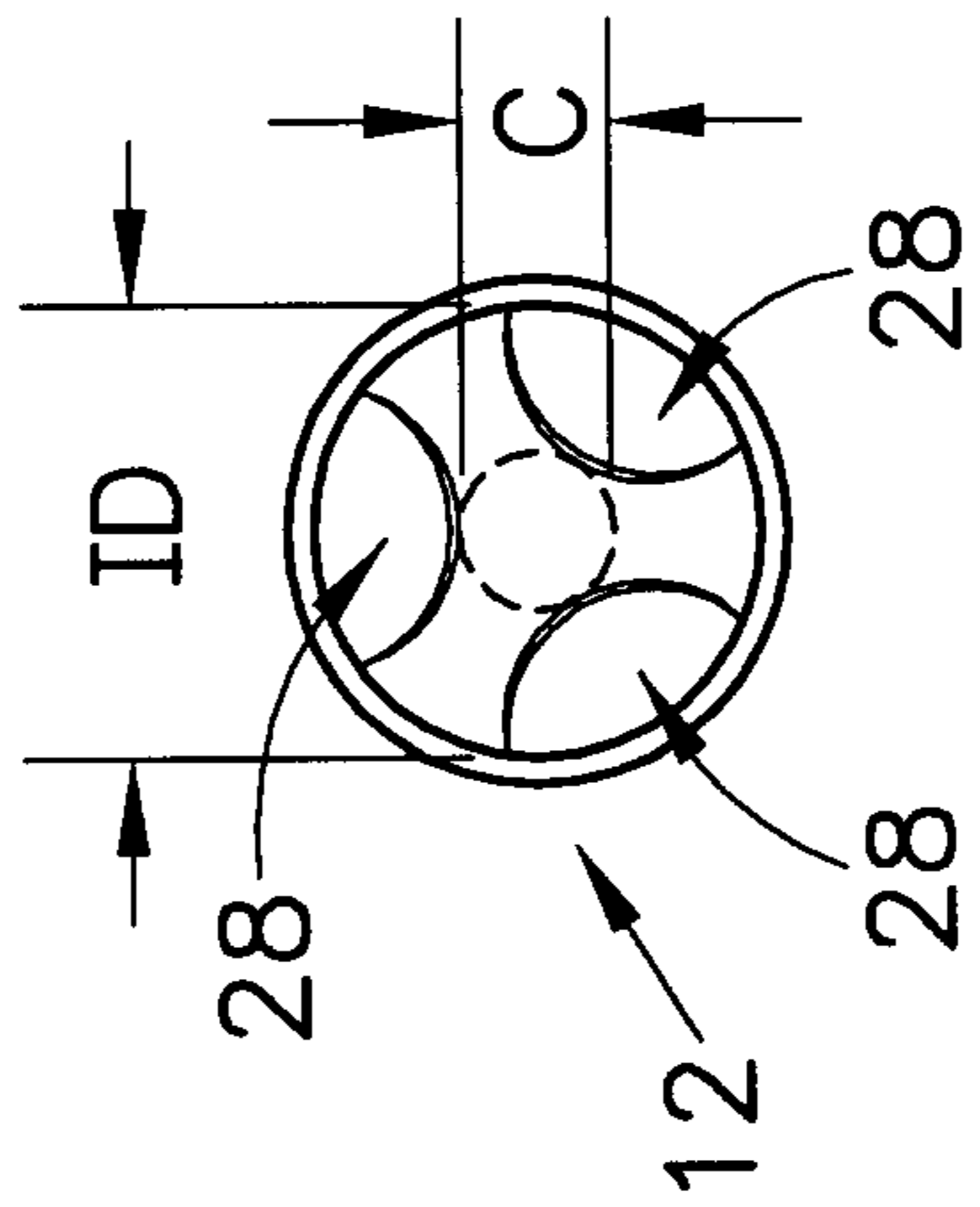

Fig. 2

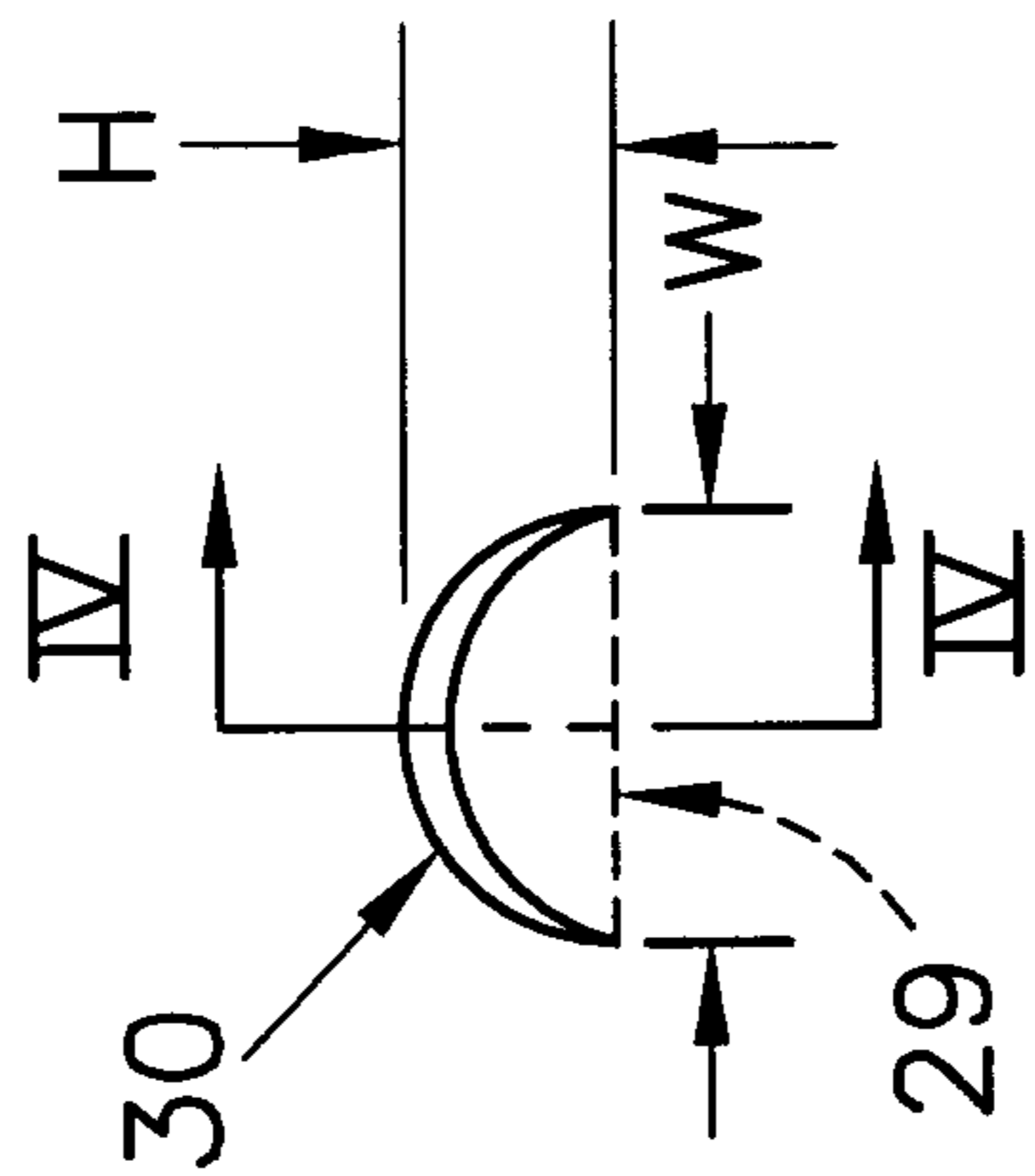

Fig. 3

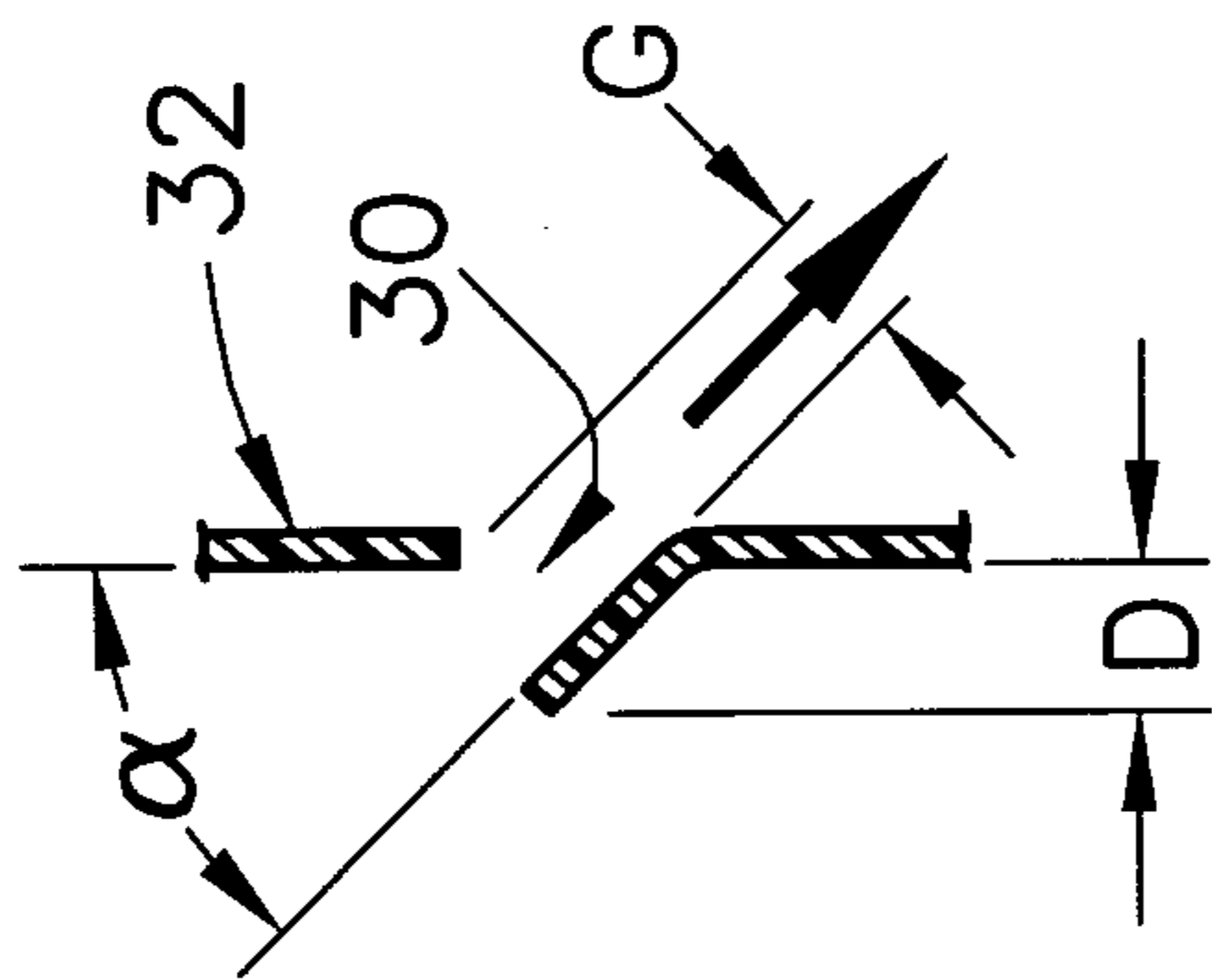

Fig. 4

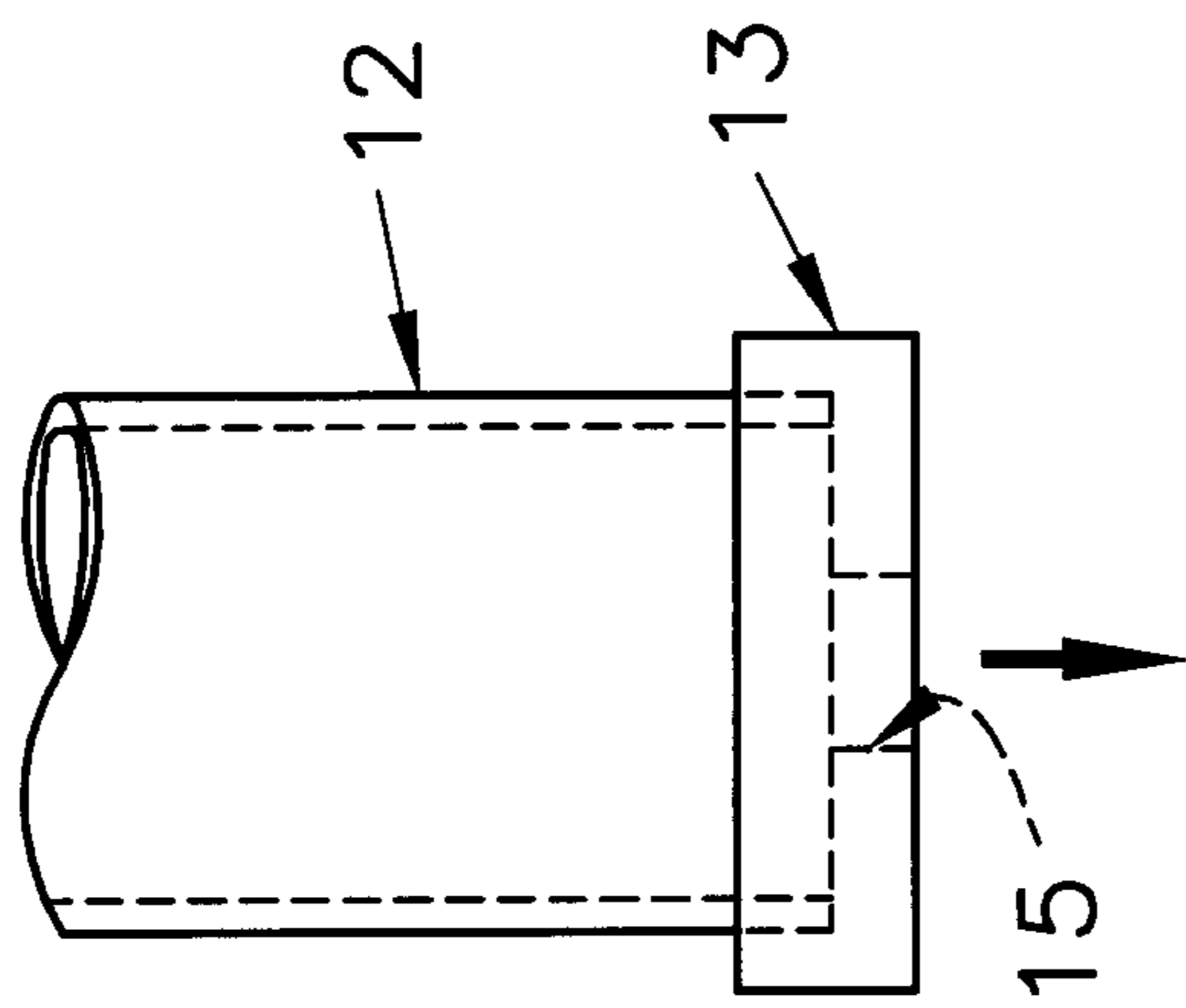

Fig. 5

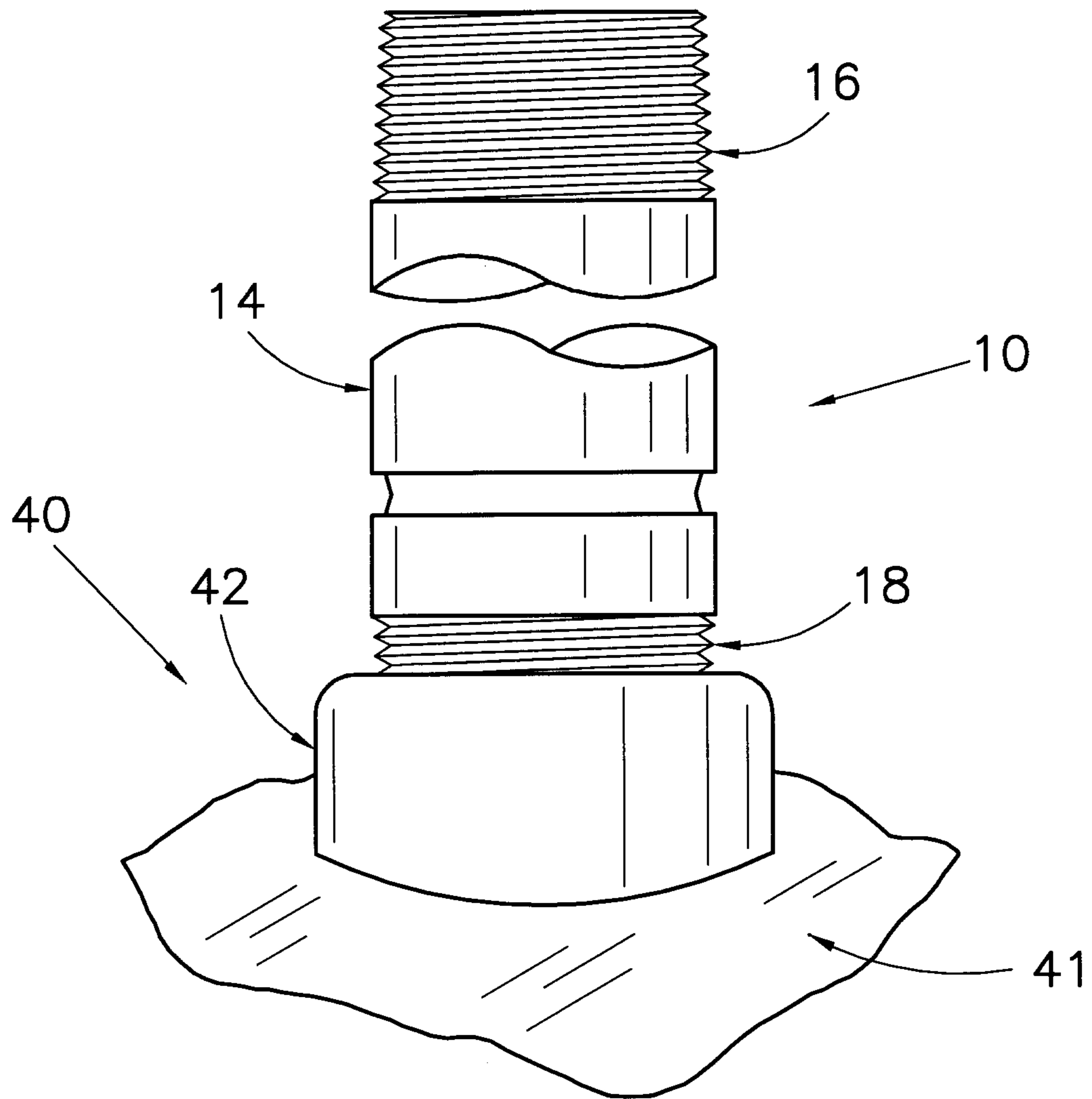

Fig. 6

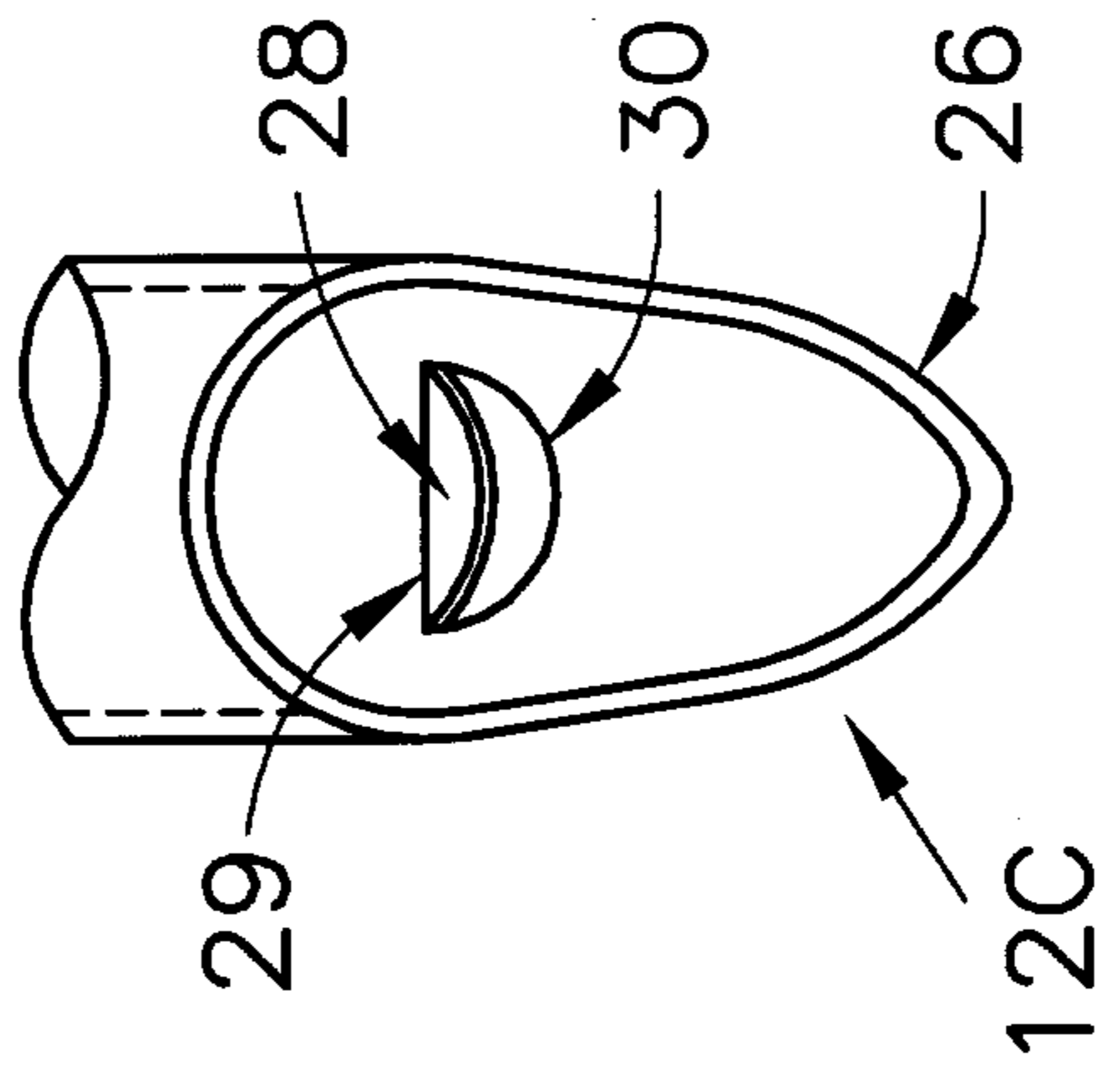

Fig. 8

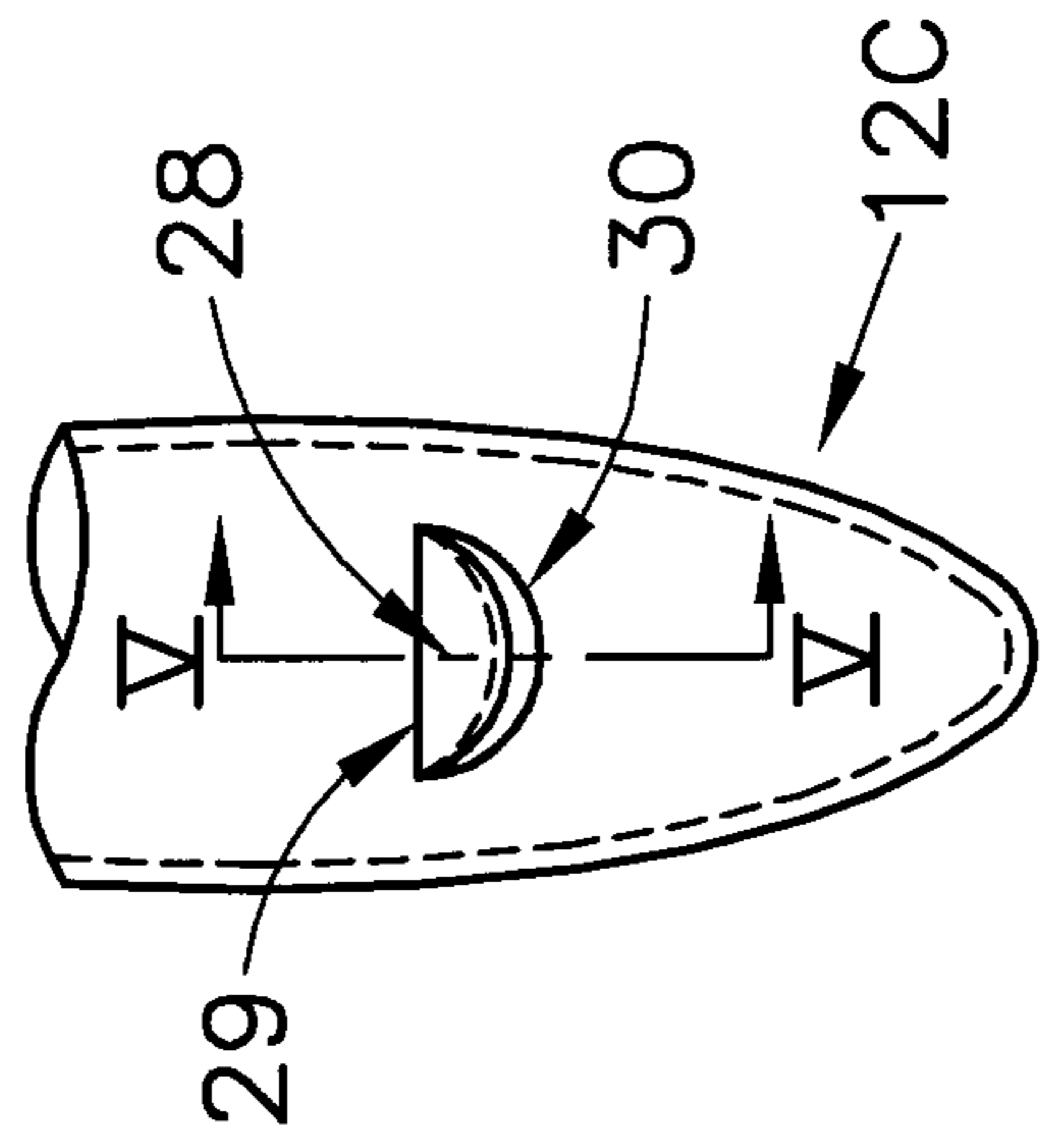

Fig. 9

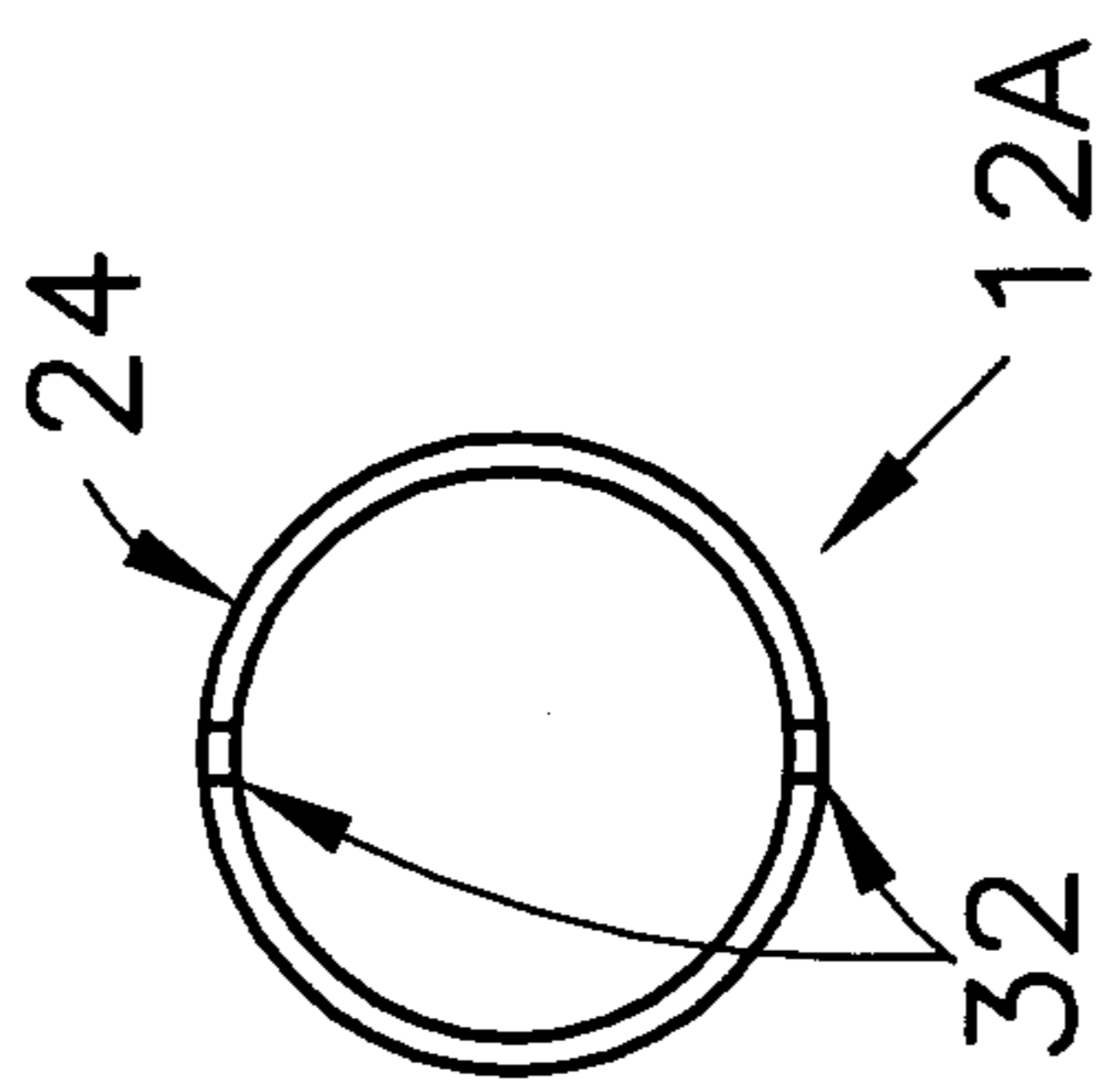

Fig. 10

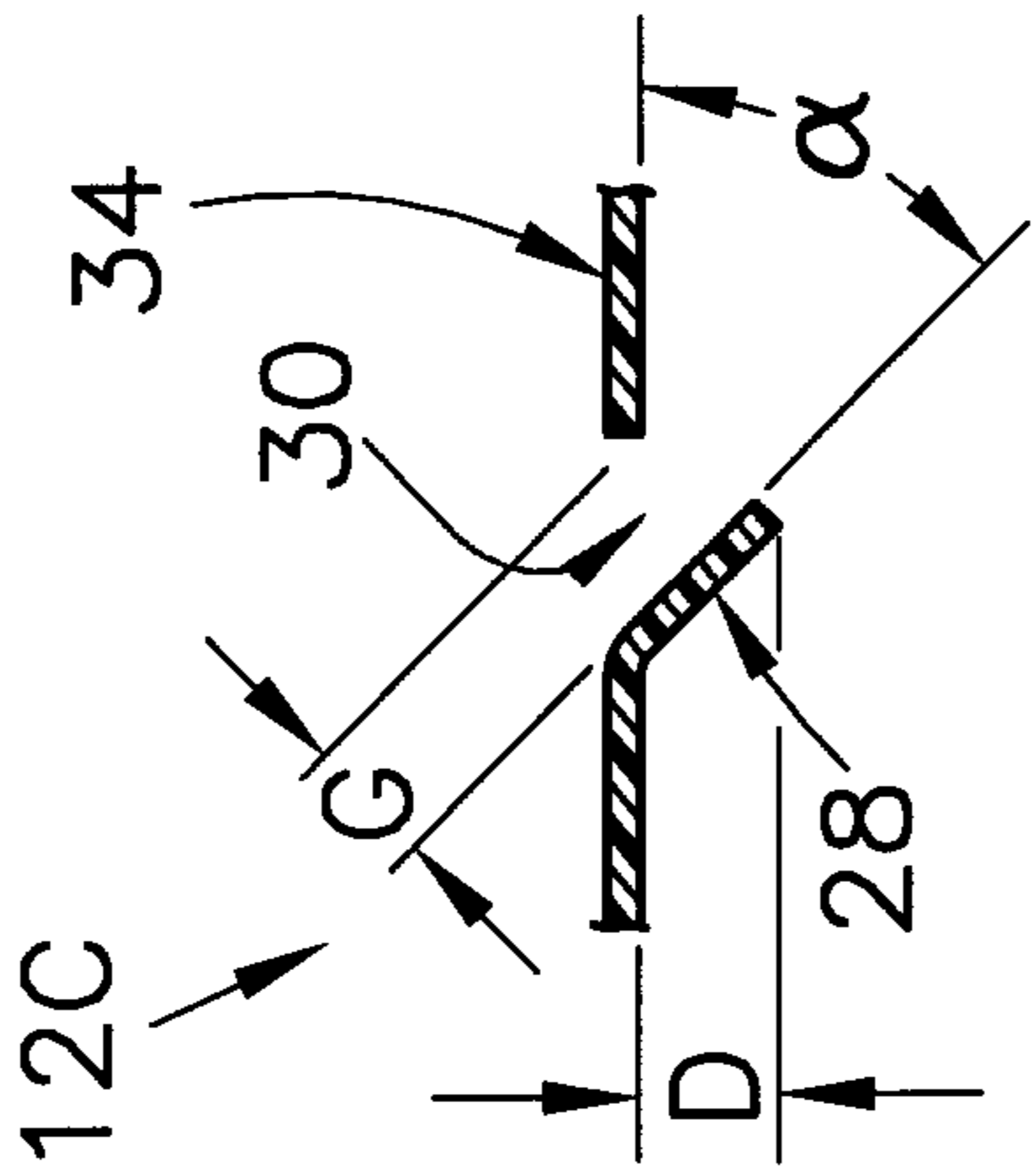

Fig. 11

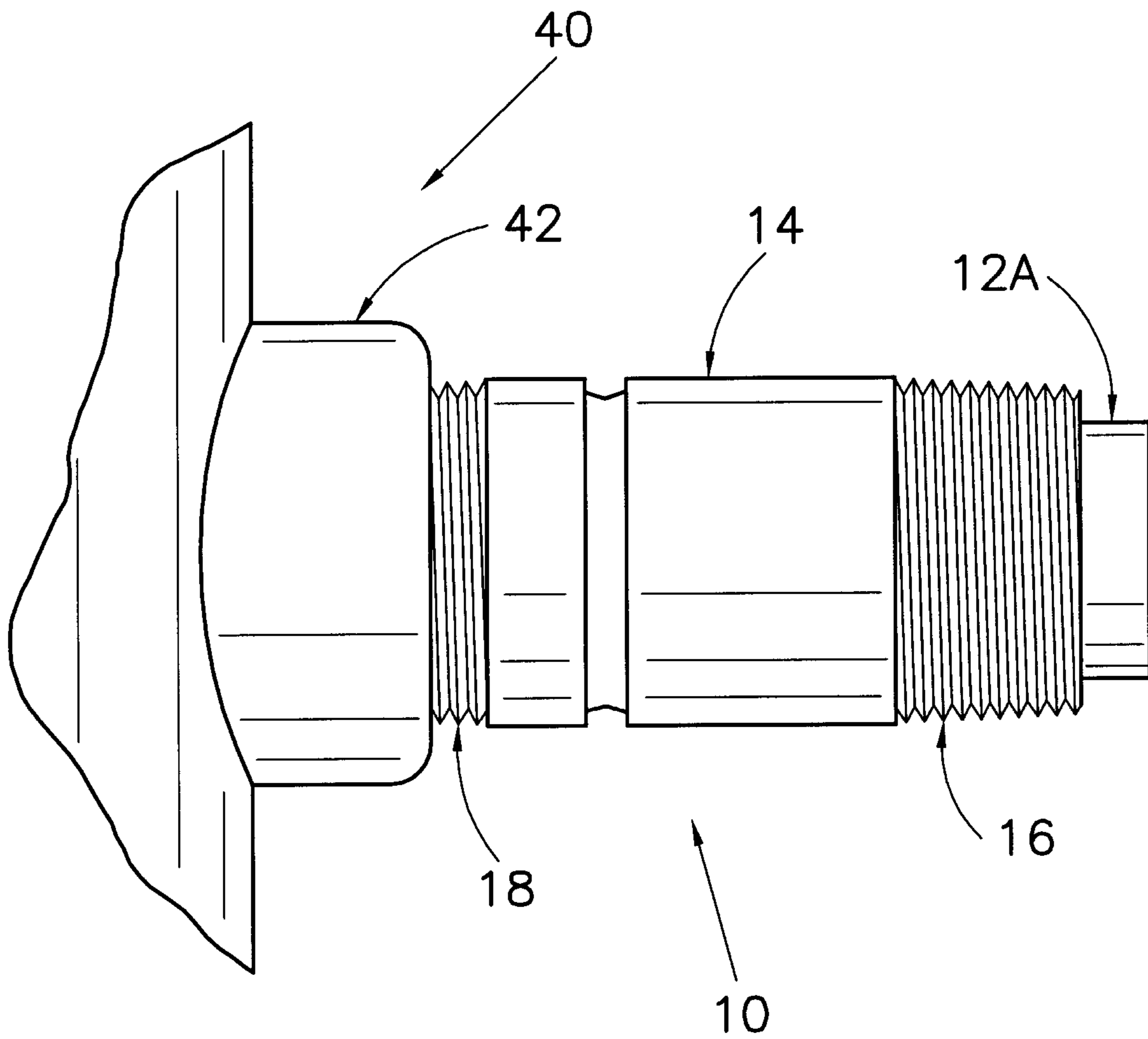

Fig. 12

