

(No Model.)

2 Sheets—Sheet 1.

J. P. ADAMS.

WATER CLOSET SUPPLY APPARATUS.

No. 382,128.

Patented May 1, 1888.

Fig. 1.

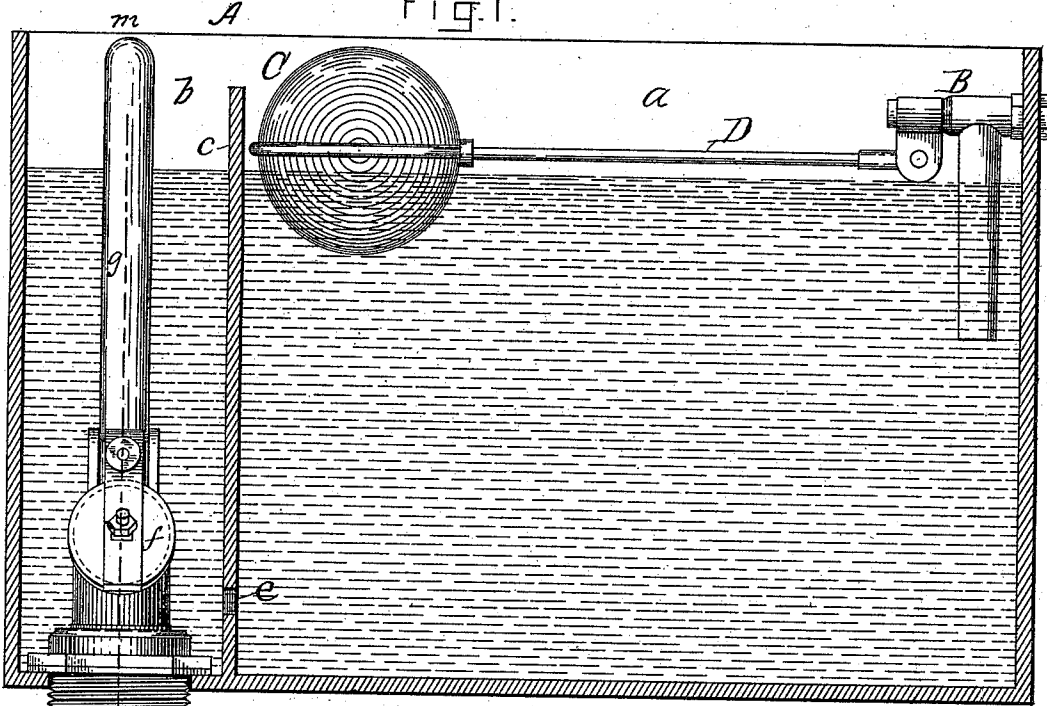

Fig. 2.

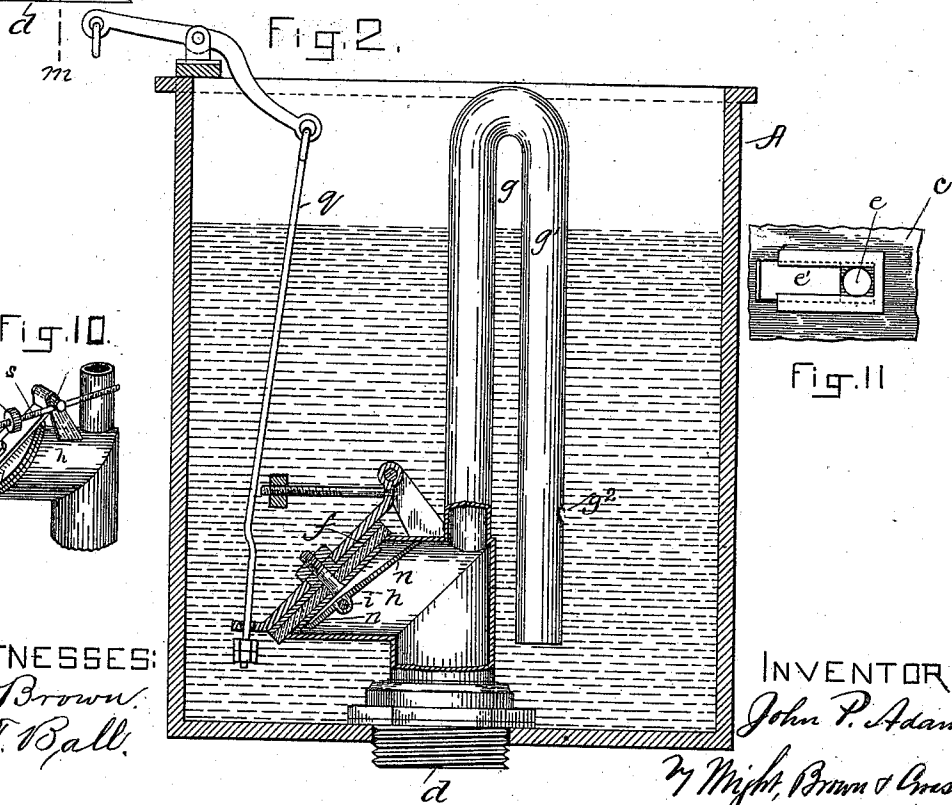

Fig. 10.

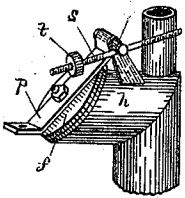
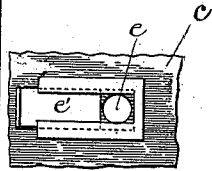

Fig. 11.



WITNESSES:
H. Brown.
J. F. Ball.

INVENTOR:
John P. Adams

Wm. Wright, Brown & Cooley
attys.

J. P. ADAMS.

WATER CLOSET SUPPLY APPARATUS.

No. 382,128.

Patented May 1, 1888.

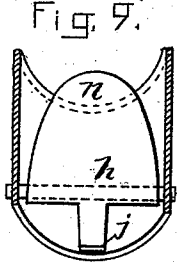

Fig. 3.

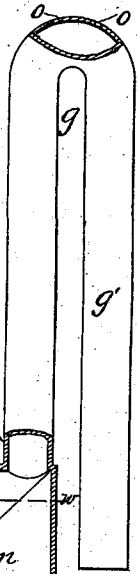

Fig. 4.

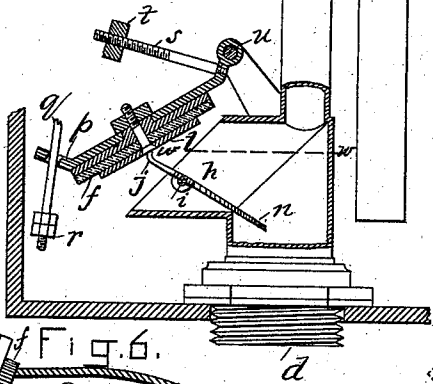
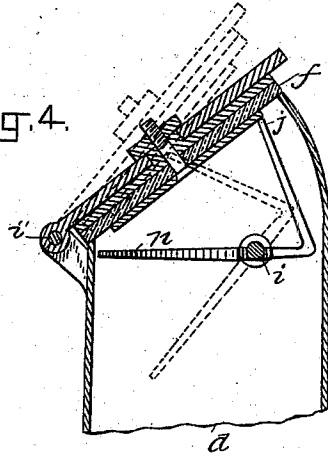

Fig. 5.

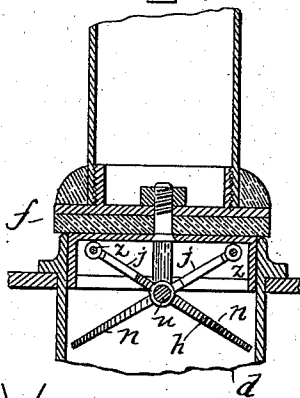
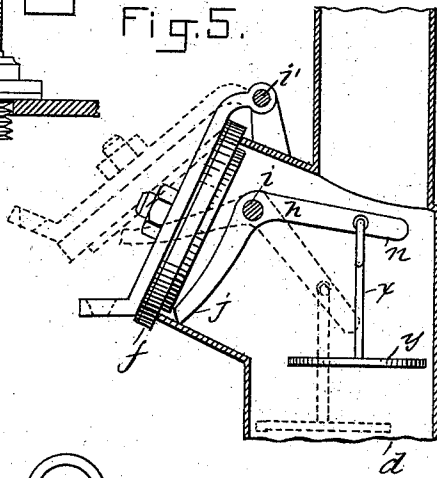
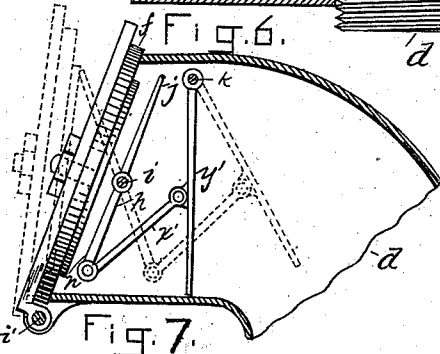
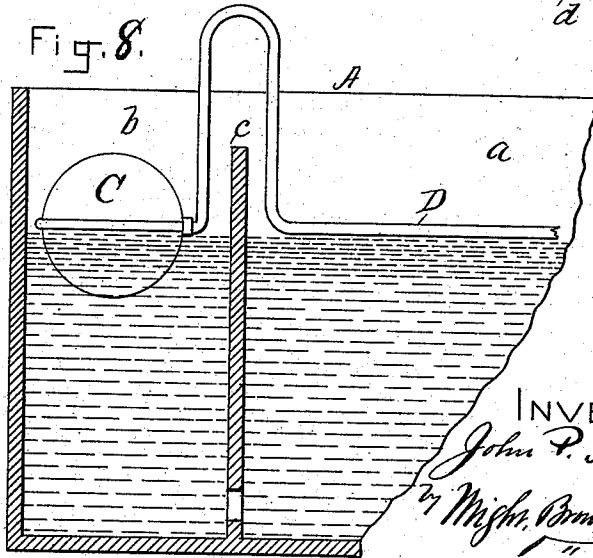

Fig. 8.



WITNESSES:
H. Brown
J. T. Ball

INVENTOR:
John P. Adams.

Wm. Mische, Brown & Crossley
attys.

UNITED STATES PATENT OFFICE.

JOHN P. ADAMS, OF CAMBRIDGE, MASSACHUSETTS.

WATER-CLOSET-SUPPLY APPARATUS.

SPECIFICATION forming part of Letters Patent No. 382,128, dated May 1, 1888.

Application filed August 12, 1887. Serial No. 246,764. (No model.)

To all whom it may concern:

Be it known that I, JOHN P. ADAMS, of Cambridge, in the county of Middlesex and State of Massachusetts, have invented certain new and useful Improvements in Water-Closet-Supply Apparatus, of which the following is a specification.

My invention relates to supply-apparatus or tanks and valves for water-closets, and particularly to that class or kind of such contrivances which are adapted to deliver a limited quantity of water to the bowl each time that the valve is operated.

My invention will first be described in connection with the accompanying drawings and the letters of reference marked thereon, forming a part of this specification, and then be pointed out in the claims.

Of the drawings, in which the same letters of reference indicate the same parts, Figure 1 represents a longitudinal vertical section of a tank fully equipped with appliances constructed in accordance with my invention. Fig. 2 is a sectional view on the line *m m* of Fig. 1. Fig. 3 is a sectional view similar to Fig. 1, showing a slightly-modified form of the siphon or overflow pipe and representing the valve as in opened instead of closed position. Figs. 4, 5, 6, and 7 show sectional views of modified forms of devices for holding the valve propped or supported in open position until a predetermined amount of water has been drawn from the tank or compartment in which the valve is located. Fig. 8 exhibits a modified arrangement of the float and means for supporting the same, whereby the ball or supply cock is operated, as hereinbefore mentioned. Fig. 9 is a sectional detail view on the line *w w* of Fig. 3. Fig. 10 is a modified view of means for weighting and adjusting the weight for depressing the valve. Fig. 11 is a detail view of means for regulating the size of the communicating-port between the main and supplemental tanks.

In the drawings, A represents a tank; B, a ball or supply cock; C, a float; D, a rod connecting the float with the ball-cock. These parts may be of common construction and arrangement, except as hereinafter noted.

The tank A is divided into a main compartment, *a*, and a supplemental compart-

ment, *b*, the division being effected by a partition, *c*. The supplemental compartment is provided with an outlet port or pipe, *d*, and the partition *c* with a port, *e*, providing for communication between the main and supplemental tanks. This communicating-port *e* is very considerably smaller than the outlet-port *d*, so that if the latter should be opened the water in the supplemental tank would be exhausted very much sooner than the water in the main tank *a*, and if said port *d* should be closed the supplemental tank would be filled from the main tank through the communicating-port *e*. The size or extent of the communicating-port may be regulated by a slide or gate, *e'*, as represented in Fig. 11, though this construction is not essential, since the slide or gate *e'* may be dispensed with, as shown in Figs. 1 and 8.

f represents a valve for opening and closing the outlet-port *d*, and *g* an overflow-pipe which may be constructed to act also as a siphon, the arm *g'* of which pipe, when the same is constructed to act as a siphon, is provided with a port, *g²*, located at any desired point, preferably slightly above the valve *f*, as shown in Fig. 2, so that if the valve should be opened, so as to start a flow of water through the outlet-port and be then closed, the water in the supplemental tank would be drawn off through the overflow or siphon pipe until lowered to a point or line corresponding with the port *g²*, when the siphon action would cease and the supplemental tank be refilled through the communicating port *e*. This same siphoning action will take place if the supplemental tank should fill to the top of the siphon-pipe *g*, so as to start the flow of water through said pipe and outlet-port *d*, and thus the overflowing of the tank may be avoided.

I have provided means for holding the valve propped or supported in open position by the action of the water until a predetermined amount has been drawn off, said means consisting of a lever, *h*, pivoted at *i* in the mouth or throat of the valve, the end of the arm *j* of which lever is adapted to act against the face *l* of the valve to hold it open, as stated. The other arm, *n*, of said lever is adapted to be operated upon either directly or indirectly by the outflowing water to cause the arm *j* to act

as described. In Figs. 3 and 9 I have shown said arm *n* as constructed as a flat tongue, so that if the valve were raised, raising the rod *g*, passing through a hole formed in a lug or projection, *p*, on the valve, and said rod were immediately released, the water flowing through the outlet-port and acting on the arm *m* of lever *h* will hold said lever in the position represented in Fig. 3, propping or maintaining the valve in open position until the weight of the water on arm *n* is overcome by the gravity of the valve *f*, when the latter will fall to its seat, as represented in Fig. 2. The nut or nuts *r* on the lower end of rod *g* effect the raising of the valve, and said rod being unobstructed above said nuts, provision is made for the rod to be lowered or depressed through the hole in the lug or extension *p* of the valve without affecting the position of the latter. In the construction just described the siphon-pipe may be provided at its upper end with holes or vents *o o*, as shown in Fig. 3, which construction will operate to admit air slowly to the overflow-pipe and outlet-port and thus avoid the hissing, roaring, and disagreeable sucking noise which would attend the operation of the device if the overflow-pipe were a single straight pipe and fully open at its upper end.

The valve *f* may be weighted and the position of its weight regulated, so as to cause said valve to fall to its seat sooner or later, as may be desired, by attaching an outwardly-extending arm, *s*, to the valve, as represented in Figs. 1 and 2, and so securing a weight, *t*, to said arm as to be adjustable in position thereon, or said arm *s* might be extended through the pivot or journal pin *i* of the lever *h*, as indicated in Fig. 10, and a weight placed on both or but one end of said arm.

In Fig. 4 I have shown the lever *h* as made angular in form, so that the valve *f* may be so arranged as that, when it is seated, to be in a more nearly horizontal position than in the construction represented in Figs. 1, 2, and 3, and to be pivoted to the outlet-pipe at the lowest point of said valve instead of the highest.

In Fig. 5 the valve is shown as hinged and seated in a manner similar to that shown in Fig. 3; but the arm *n* is depressed by the action of the water on a disk, *y*, arranged in the throat of the outlet-port *d*, said disk being connected with the arm *n* of lever *h* by means of a link, *x*.

By the construction shown in Fig. 6 arm *j* of lever *h* is adapted to operate more lightly

against the face *l* of the valve than in the other forms described. In this construction arm *n* is moved from its full to its dotted line position by the action of the water on disk *y'*, hinged or pivoted at *k* to the pipe of the outlet-port, said disk *y'* being connected with said arm *h* by means of a link, *x'*.

In Fig. 7 I have represented a construction in which the valve may be arranged in a horizontal position, so as to rise and fall vertically. In this form of the invention two levers, *h*, may be pivoted on a common pivot or journal pin, *u*, and be provided on their upper ends with bowls or trundle-rollers *z*, to act against the face of the valve. In this instance the levers *h* each operate in much the same manner and have much the same construction otherwise than as described in Figs. 2 and 3.

I prefer to arrange the float *C* in the supplemental chamber *b*, as shown in Fig. 8, curving the rod *D* over the partition *c*, so that as the water is quickly drawn off from said supplemental chamber in any manner said float may quickly rise and fall, so as in like way to open and close ball or supply cock *B*.

It is obvious that changes may be made in the form and arrangement of parts constituting the invention without departing from the nature or spirit thereof.

I claim—

1. In a tank for water closets, having an outlet-port, combined with a valve for opening and closing said port, and a lever pivoted in the mouth or throat of the outlet-port, one arm of said lever acting against the valve and the other extending into the water-way or throat of the outlet-port, substantially as hereinbefore set forth.

2. A tank for water-closets, having a main and supplemental compartment, an outlet-port in the supplemental compartment, a valve to open and close said outlet-port, a port communicating between the two compartments, and a lever pivoted in the mouth or throat of the outlet-port, one arm of said lever acting against the valve and the other extending into the water-way or throat of the outlet-port, substantially as hereinbefore set forth.

In testimony whereof I have signed my name to this specification, in the presence of two subscribing witnesses, this 6th day of August, 1887.

JOHN P. ADAMS.

Witnesses:

ARTHUR W. CROSSLEY,
C. F. BROWN.