

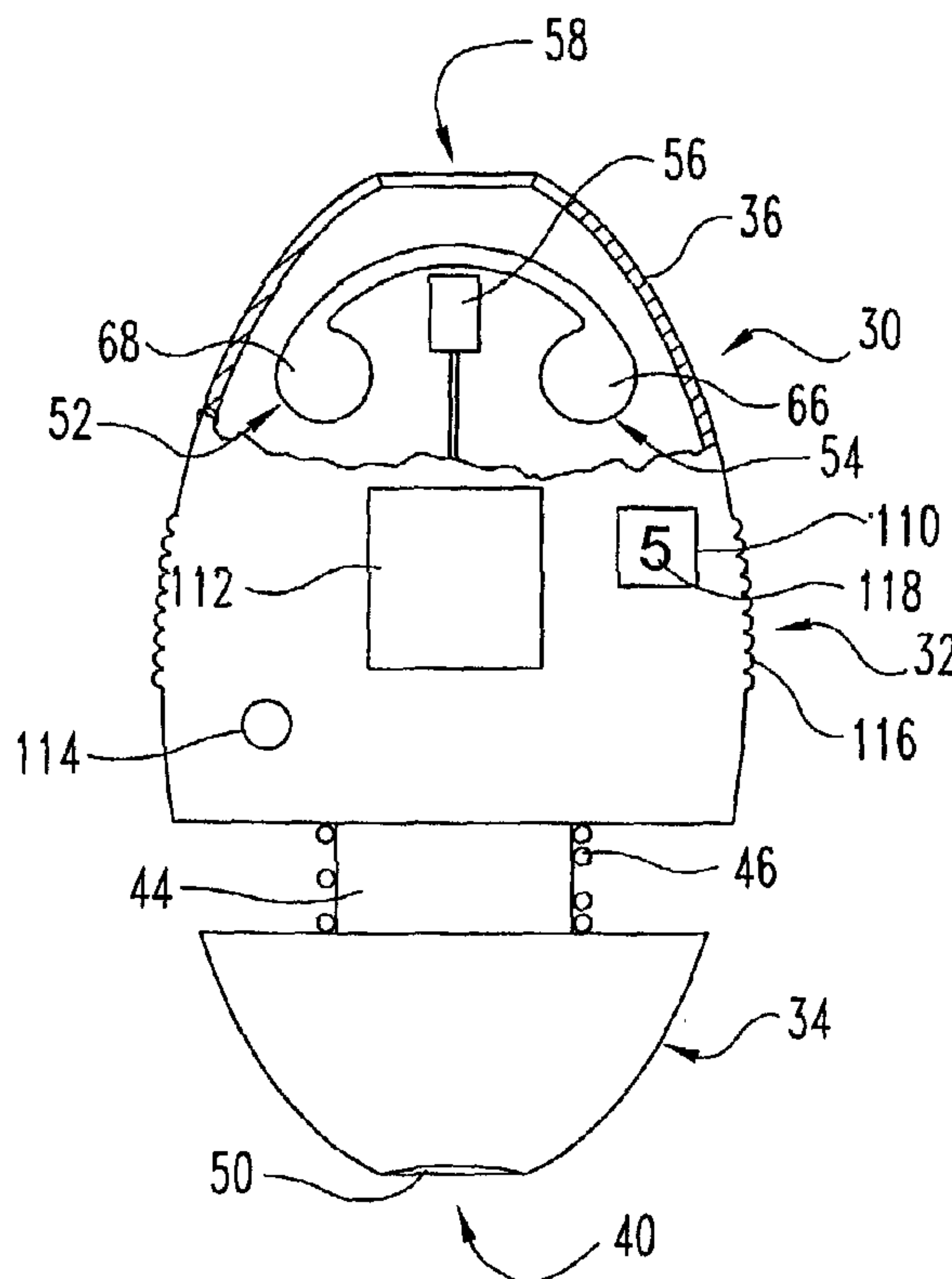

(86) Date de dépôt PCT/PCT Filing Date: 2002/06/07
 (87) Date publication PCT/PCT Publication Date: 2002/12/19
 (85) Entrée phase nationale/National Entry: 2003/12/04
 (86) N° demande PCT/PCT Application No.: US 2002/018159
 (87) N° publication PCT/PCT Publication No.: 2002/100274
 (30) Priorité/Priority: 2001/06/08 (60/296,989) US

(51) Cl.Int.⁷/Int.Cl.⁷ A61B 5/15, A61B 10/00
 (71) Demandeur/Applicant:
 F. HOFFMANN-LA ROCHE AG, CH
 (72) Inventeurs/Inventors:
 ROE, JEFFREY N., US;
 ROE, STEVEN N., US
 (74) Agent: OGILVY RENAULT

(54) Titre : DISPOSITIF DE PRELEVEMENT DE LIQUIDE CORPOREL ET CASSETTE A SUPPORT D'ESSAI
 DESTINEE A ETRE UTILISEE AVEC LEDIT DISPOSITIF
 (54) Title: BODILY FLUID SAMPLING DEVICE AND TEST MEDIA CASSETTE TO BE USED WITH SUCH A DEVICE



(57) **Abrégé/Abstract:**

A bodily fluid sampling device (30) includes a piercing device (42) and a sensor (56) enclosed in a housing (32). A cassette (54), which contains test media (64), is positioned proximal to the sensor (56) so that the sensor (56) is able to analyze a bodily fluid sample collected on the test media (64). The cassette (54) includes a supply portion (66) from which unused test media (64) is supplied and a storage portion (68) in which contaminated test media (64) is stored after exposure to the bodily fluid. The cassette (54) is adapted to collect a series of bodily fluid samples without requiring disposal of the test media (64).

(12) INTERNATIONAL APPLICATION PUBLISHED UNDER THE PATENT COOPERATION TREATY (PCT)

(19) World Intellectual Property Organization
International Bureau(43) International Publication Date
19 December 2002 (19.12.2002)

PCT

(10) International Publication Number
WO 02/100274 A1(51) International Patent Classification⁷: A61B 5/15, 10/00

[US/US]; 3212 Veracruz Drive, San Ramon, CA 94583 (US). ROE, Steven, N. [US/US]; 21 Hillbarn Court, San Mateo, CA 94403 (US).

(21) International Application Number: PCT/US02/18159

(22) International Filing Date: 7 June 2002 (07.06.2002)

(74) Agents: HENRY, Thomas, Q. et al.; Woodard, Emhardt, Naughton, Moriarty & McNett, Bank One Center/Tower, Suite 3700, 111 Monument Circle, Indianapolis, IN 46204 (US).

(25) Filing Language: English

(26) Publication Language: English

(30) Priority Data:
60/296,989 8 June 2001 (08.06.2001) US(81) Designated States (*national*): AE, AG, AL, AM, AT, AU, AZ, BA, BB, BG, BR, BY, BZ, CA, CH, CN, CO, CR, CU, CZ, DE, DK, DM, DZ, EC, EE, ES, FI, GB, GD, GE, GH, GM, HR, HU, ID, IL, IN, IS, JP, KE, KG, KP, KR, KZ, LC, LK, LR, LS, LT, LU, LV, MA, MD, MG, MK, MN, MW, MX, MZ, NO, NZ, OM, PH, PL, PT, RO, RU, SD, SE, SG, SI, SK, SL, TJ, TM, TN, TR, TT, TZ, UA, UG, US, UZ, VN, YU, ZA, ZM, ZW.(71) Applicant (*for all designated States except US*): AMIRA MEDICAL [US/US]; 9115 Hague Road, Indianapolis, Indiana 46256 (US).

(72) Inventors; and

(75) Inventors/Applicants (*for US only*): ROE, Jeffrey, N.(84) Designated States (*regional*): ARIPO patent (GH, GM, KE, LS, MW, MZ, SD, SL, SZ, TZ, UG, ZM, ZW),

[Continued on next page]

(54) Title: BODILY FLUID SAMPLING DEVICE AND TEST MEDIA CASSETTE TO BE USED WITH SUCH A DEVICE

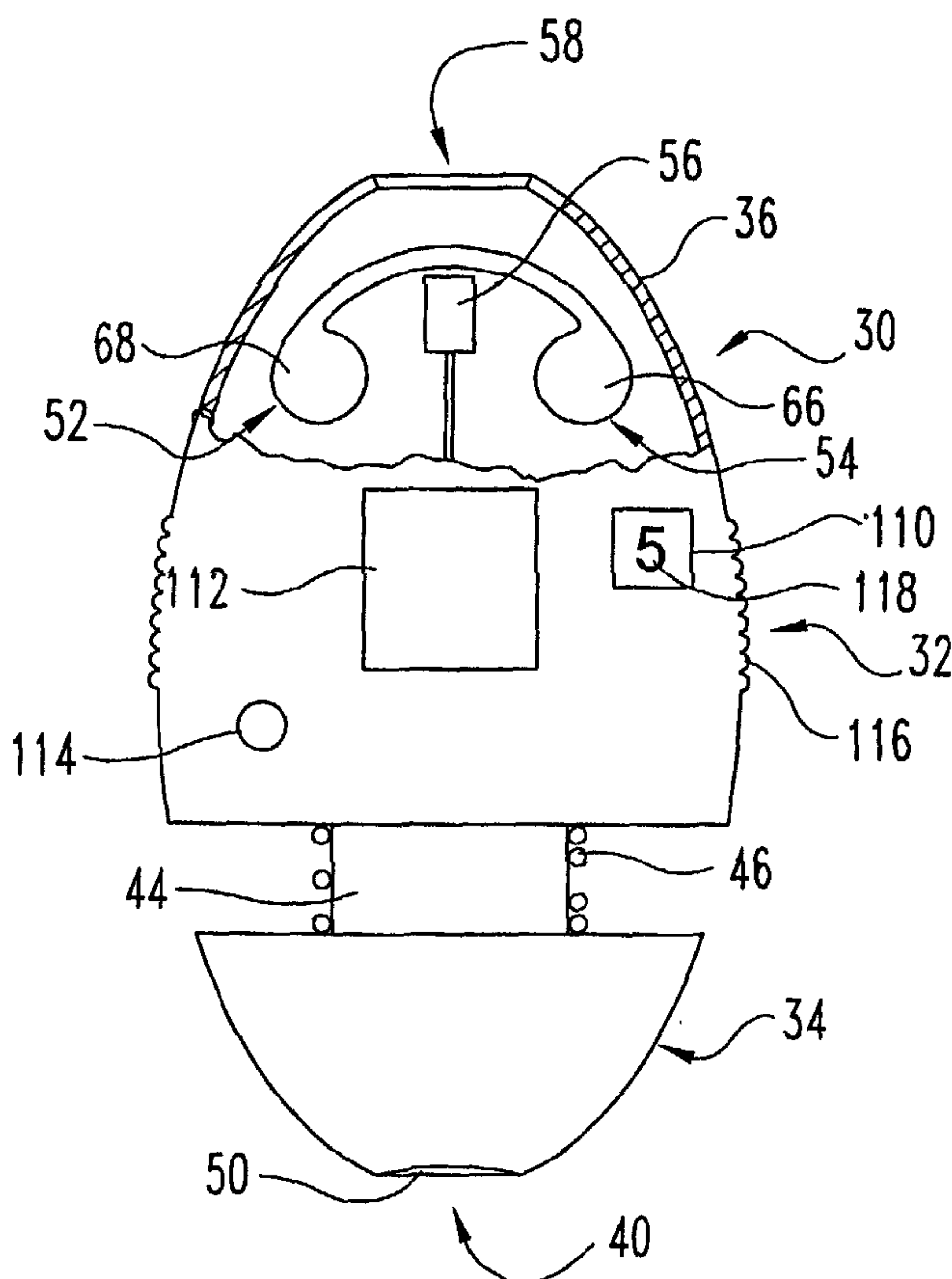

(57) Abstract: A bodily fluid sampling device (30) includes a piercing device (42) and a sensor (56) enclosed in a housing (32). A cassette (54), which contains test media (64), is positioned proximal to the sensor (56) so that the sensor (56) is able to analyze a bodily fluid sample collected on the test media (64). The cassette (54) includes a supply portion (66) from which unused test media (64) is supplied and a storage portion (68) in which contaminated test media (64) is stored after exposure to the bodily fluid. The cassette (54) is adapted to collect a series of bodily fluid samples without requiring disposal of the test media (64).

WO 02/100274 A1

WO 02/100274 A1



Eurasian patent (AM, AZ, BY, KG, KZ, MD, RU, TJ, TM),
European patent (AT, BE, CH, CY, DE, DK, ES, FI, FR,
GB, GR, IE, IT, LU, MC, NL, PT, SE, TR), OAPI patent
(BF, BJ, CF, CG, CI, CM, GA, GN, GQ, GW, ML, MR,
NE, SN, TD, TG).

For two-letter codes and other abbreviations, refer to the "Guidance Notes on Codes and Abbreviations" appearing at the beginning of each regular issue of the PCT Gazette.

Published:

— *with international search report*

BODILY FLUID SAMPLING DEVICE AND TEST MEDIA CASSETTE TO BE USED WITH SUCH A
DEVICE

REFERENCE TO RELATED APPLICATIONS

This application claims the benefit of U.S. Provisional Patent Application
5 No. 60/296,989, filed June 8, 2001, which is hereby incorporated by reference in
its entirety.

BACKGROUND OF THE INVENTION

The present invention relates to bodily fluid sampling devices, and more
specifically, but not exclusively, concerns a bodily fluid sampling device that
10 incorporates a test media cassette that contains test media used to test bodily fluid.

General Fluid Testing

The acquisition and testing of bodily fluids is useful for many purposes,
and continues to grow in importance for use in medical diagnosis and treatment,
and in other diverse applications. In the medical field, it is desirable for lay
15 operators to perform tests routinely, quickly and reproducibly outside of a
laboratory setting, with rapid results and a readout of the resulting test information.
Testing can be performed on various bodily fluids, and for certain applications is
particularly related to the testing of blood and/or interstitial fluid. Such fluids can
be tested for a variety of characteristics of the fluid, or analytes contained in the
20 fluid, in order to identify a medical condition, determine therapeutic responses,
assess the progress of treatment, and the like.

General Test Steps

The testing of bodily fluids basically involves the steps of obtaining the
fluid sample, transferring the sample to a test device, conducting a test on the fluid
25 sample, and displaying the results. These steps are generally performed by a
plurality of separate instruments or devices.

Acquiring – Vascular

One method of acquiring the fluid sample involves inserting a hollow
needle or syringe into a vein or artery in order to withdraw a blood sample.
30 However, such direct vascular blood sampling can have several limitations,
including pain, infection, and hematoma and other bleeding complications. In

addition, direct vascular blood sampling is not suitable for repeating on a routine basis, can be extremely difficult and is not advised for patients to perform on themselves.

Acquiring – Incising

5 The other common technique for collecting a bodily fluid sample is to form an incision in the skin to bring the fluid to the skin surface. A lancet, knife or other cutting instrument is used to form the incision in the skin. The resulting blood or interstitial fluid specimen is then collected in a small tube or other container, or is placed directly in contact with a test strip. The fingertip is frequently used as the
10 fluid source because it is highly vascularized and therefore produces a good quantity of blood. However, the fingertip also has a large concentration of nerve endings, and lancing the fingertip can therefore be painful. Alternate sampling sites, such as the palm of the hand, forearm, earlobe and the like, may be useful for sampling, and are less painful. However, they also produce lesser amounts of
15 blood. These alternate sites therefore are generally appropriate for use only for test systems requiring relatively small amounts of fluid, or if steps are taken to facilitate the expression of the bodily fluid from the incision site.

 Various methods and systems for incising the skin are known in the art. Exemplary lancing devices are shown, for example, in United States Patent Nos.
20 Re 35,803, issued to Lange, et al. on May 19, 1998.; 4,924,879, issued to O'Brien on May 15, 1990; 5,879,311, issued to Duchon et al. on February 16, 1999; 5,857,983, issued to Douglas on January 12, 1999; 6,183,489, issued to Douglas et al. on February 6, 2001; 6,332,871, issued to Douglas et al. on December 25, 2001; and 5,964,718, issued to Duchon et al. on October 12, 1999. A representative
25 commercial lancing device is the Accu-Chek Softclix lancet.

Expressing

 Patients are frequently advised to urge fluid to the incision site, such as by applying pressure to the area surrounding the incision to milk or pump the fluid from the incision. Mechanical devices are also known to facilitate the expression
30 of bodily fluid from an incision. Such devices are shown, for example, in United States Patent Nos. 5,879,311, issued to Duchon et al. on February 16, 1999;

5,857,983, issued to Douglas on January 12, 1999; 6,183,489, issued to Douglas et al. on February 6, 2001; 5,951,492, issued to Douglas et al. on September 14, 1999; 5,951,493, issued to Douglas et al. on September 14, 1999; 5,964,718, issued to Duchon et al. on October 12, 1999; and 6,086,545, issued to Roe et al. on July 11, 2000. A representative commercial product that promotes the expression of bodily fluid from an incision is the Amira AtLast blood glucose system.

Sampling

The acquisition of the produced bodily fluid, hereafter referred to as the “sampling” of the fluid, can take various forms. Once the fluid specimen comes to the skin surface at the incision, a sampling device is placed into contact with the fluid. Such devices may include, for example, systems in which a tube or test strip is either located adjacent the incision site prior to forming the incision, or is moved to the incision site shortly after the incision has been formed. A sampling tube may acquire the fluid by suction or by capillary action. Such sampling systems may include, for example, the systems shown in US Patent Nos. 6,048,352, issued to Douglas et al. on April 11, 2000; 6,099,484, issued to Douglas et al. on August 8, 2000; and 6,332,871, issued to Douglas et al. on December 25, 2001. Examples of commercial sampling devices include the Roche Compact, Amira AtLast, Glucometer Elite and Therasense FreeStyle test strips.

Testing General

The bodily fluid sample may be analyzed for a variety of properties or components, as is well known in the art. For example, such analysis may be directed to hematocrit, blood glucose, coagulation, lead, iron, etc. Testing systems include such means as optical (e.g., reflectance, absorption, fluorescence, Raman, etc.), electrochemical, and magnetic means for analyzing the sampled fluid. Examples of such test systems include those in US Patent Nos. 5,824,491, issued to Priest et al. on October 20, 1998; 5,962,215, issued to Douglas et al. on October 5, 1999; and 5,776,719, issued to Douglas et al. on July 7, 1998.

Typically, a test system takes advantage of a reaction between the bodily fluid to be tested and a reagent present in the test system. For example, an optical test strip will generally rely upon a color change, i.e., a change in the wavelength

absorbed or reflected by dye formed by the reagent system used. See, e.g., US Patent Nos. 3,802,842; 4,061,468; and 4,490,465.

Blood Glucose

5 A common medical test is the measurement of blood glucose level. The glucose level can be determined directly by analysis of the blood, or indirectly by analysis of other fluids such as interstitial fluid. Diabetics are generally instructed to measure their blood glucose level several times a day, depending on the nature and severity of their diabetes. Based upon the observed pattern in the measured glucose levels, the patient and physician determine the appropriate level of insulin
10 to be administered, also taking into account such issues as diet, exercise and other factors.

In testing for the presence of an analyte such as glucose in a bodily fluid, test systems are commonly used which take advantage of an oxidation/reduction reaction which occurs using an oxidase/peroxidase detection chemistry. The test
15 reagent is exposed to a sample of the bodily fluid for a suitable period of time, and there is a color change if the analyte (glucose) is present. Typically, the intensity of this change is proportional to the concentration of analyte in the sample. The color of the reagent is then compared to a known standard which enables one to determine the amount of analyte present in the sample. This determination can be
20 made, for example, by a visual check or by an instrument, such as a reflectance spectrophotometer at a selected wavelength, or a blood glucose meter.

Electrochemical and other systems are also well known for testing bodily fluids for properties on constituents.

Testing Media

25 As mentioned above, diabetics typically have to monitor their blood glucose levels throughout the day so as to ensure that their blood glucose remains within an acceptable range. Some types sampling devices require the use of testing strips that contain media for absorbing and/or testing the bodily fluid, such as blood. After testing, the testing media contaminated with blood can be considered
30 a biohazard and needs to be readily disposed in order to avoid other individuals from being exposed to the contaminated test strip. This can be especially

inconvenient when the person is away from home, such as at restaurant.

Moreover, the individual test strips can become easily mixed with other test strips having different expiration dates. The use of expired test strips may create false readings, which can result in improper treatment of the patient, such as improper

5 insulin dosages for diabetics.

SUMMARY OF THE INVENTION

The present invention provides various systems and methods for sampling
bodily fluid. The present invention encompasses a bodily fluid sampling device
5 that incorporates a cassette containing test media.

In accordance with one aspect of the present invention, there is provided a
bodily fluid sampling device for analyzing a bodily fluid. The sampling device
includes a test media cassette that includes a test media tape adapted to collect the
bodily fluid. The cassette includes a supply portion that stores an uncontaminated
10 section of the test media tape, which is uncontaminated with the bodily fluid. A
storage portion stores a contaminated section of the test media tape that is
contaminated with the bodily fluid. An exposure portion is positioned between the
supply portion and the storage portion. The exposure portion is adapted to expose
a section of the test media tape to the bodily fluid. A sensor is positioned between
15 the supply portion and the storage portion to sense at least one property of the
bodily fluid collected on the test media tape at the exposure portion of the cassette.

Another aspect of the present invention concerns a test cassette for
collecting a bodily fluid sample. The cassette includes a test media tape, which has
a contaminated section that is contaminated with past samples of the bodily fluid
20 and an uncontaminated section. The cassette includes a housing that has a supply
portion in which the uncontaminated section of the test media tape is enclosed.
The housing further includes a storage portion in which the contaminated section
of the test media tape is enclosed. The housing defines an exposure opening along
the test media tape at which the test media tape is exposed to the bodily fluid. A
25 supply reel is disposed in the supply portion of the housing around which the
uncontaminated section of the test media tape is wrapped. A storage reel is
disposed in the storage portion of the housing around which the contaminated
section of the test media tape is wrapped.

Other forms, embodiments, objects, features, advantages, benefits and
30 aspects of the present invention shall become apparent from the detailed drawings
and description contained herein.

BRIEF DESCRIPTION OF THE DRAWINGS

FIG. 1 is a partial, cross-sectional view of a bodily fluid sampling device according to one embodiment of the present invention.

FIG. 2 is a cross-sectional view of a test cassette and sensor used in the
5 FIG. 1 sampling device.

FIG. 3 is a partial, side view of the FIG. 2 cassette.

FIG. 4 is a cross-sectional view of the FIG. 1 sampling device.

FIG. 5 is a front view of an indexing mechanism used in the FIG. 1
10 sampling device.

FIG. 6 is a cross-sectional view of a test cassette according to another
15 embodiment of the present invention.

FIG. 7 is a cross-sectional view of a bodily fluid sampling device according to another embodiment of the present invention.

FIG. 8 is a front view of test media used in the FIG. 7 sampling device.

FIG. 9 is a side view of the FIG. 8 test media.
15

FIG. 10 is a side view of the FIG. 8 test media with a piercing device from the FIG. 7 sampling device.

FIG. 11 is a cross-sectional view of a bodily fluid sampling device according to another embodiment of the present invention.

FIG. 12 is a diagrammatic view of a sensor system according to another
20 embodiment of the present invention.

FIG. 13 is a cross-sectional view of a bodily fluid testing system according to another embodiment of the present invention.

FIG. 14 is a cross-sectional view of test media used in the FIG. 13 sampling
25 device.

FIG. 15 is an enlarged, cross-sectional view of a portion of the FIG. 14 test media.

DESCRIPTION OF SELECTED EMBODIMENTS

For the purposes of promoting an understanding of the principles of the invention, reference will now be made to the embodiments illustrated in the drawings and specific language will be used to describe the same. It will
5 nevertheless be understood that no limitation of the scope of the invention is thereby intended, such alterations and further modifications in the illustrated device, and such further applications of the principles of the invention as illustrated therein being contemplated as would normally occur to one skilled in the art to which the invention relates. One embodiment of the invention is shown in great
10 detail, although it will be apparent to those skilled in the art that some of the features which are not relevant to the invention may not be shown for the sake of clarity.

The present invention concerns a bodily fluid sampling device that incorporates a test cassette. The cassette houses test media that is used to collect
15 bodily fluid samples which are analyzed with a sensor in the sampling device. The test media in the cassette is indexed before or after each test so that successive tests can be performed without requiring disposal of the used test media. The test media can be indexed manually or automatically. In one aspect of the present invention, the test media includes a cover tape that protects the test media before testing. In
20 another aspect, the test media defines one or more passageways through which a piercing device is able to pass through in order to pierce the skin of a user. The cassette, in another aspect of the present invention, is designed for use with a vacuum-style sampling device in which the bodily fluid sample is drawn to the test media by a vacuum.

25 A bodily fluid sampling device 30 according to one embodiment of the present invention is illustrated in FIGS. 1-5. As shown in FIGS. 1 and 4, the sampling device 30 includes a housing 32 with a piercing end portion 34 and an opposite, sampling end portion 36. The piercing portion 34 of the housing 32 is slidable relative to the sampling portion 36. As shown in FIG. 4, piercing portion
30 34 defines a piercing device cavity 38 with a piercing device opening 40. In the piercing cavity 38, a piercing device or member 42, which is used for puncturing

skin, is covered by the piercing portion 34 of the housing 32 to avoid accidental piercing of the skin. The piercing device 42 cuts an incision in the skin such that the bodily fluid, such as blood, pools on the surface of the skin. In one embodiment, the piercing device 42 includes a lancet suitable to puncture the cutaneous layer of the skin. As should be appreciated, other types of piercing devices 42 can also be used, such as needles and blades, to name a few.

As illustrated in FIG. 4, the piercing portion 34 of the housing 32 is slidably received on a slide member 44 that extends from the sampling portion 36 of the housing 32. The piercing device 42 is removably coupled to the slide member 44. A spring 46 on the slide member 44 biases the piercing portion 34 of the housing 32 away from the sampling portion 36, and a stop member 48 on the slide member 44 prevents the piercing portion 34 from sliding off the slide member 44. Normally, the piercing portion 34 of the housing 32 covers the piercing device 42. Once the piercing portion 34 is pressed against the skin, the piercing portion 34 retracts towards the sampling portion 36 of the housing 32 to expose the piercing device 42 through opening 40. In the illustrated embodiment, the piercing portion 34 of the housing 32 has a compression ring 50 around opening 40 in order to draw the bodily fluid to the surface of the skin. In one form, the compression ring 50 is clear so that the user can view the pooling of the bodily fluid.

Referring to FIG. 1, the bodily fluid sampling device 30 includes a sampling system 52 for sampling and testing the drawn bodily fluid. As shown, the sampling system 52 includes a test cassette 54 and a sensor 56. In one embodiment, the sensor 56 is an optical sensor that includes a light source and a detector for determining the amount of light reflected from the collected sample. It should be appreciated, however, that other types of sensors 56 can be used to monitor analyte levels in bodily fluid. For example, the sensor 56 can include an electrical type sensor that measures the electrical and/or electrochemical properties of the sample. The sampling portion 36 of the housing 32 defines a bodily fluid acquisition opening 58 through which the bodily fluid is supplied to the cassette 54. In one embodiment, the cassette 54 is removably coupled to the sampling device 30 such that the cassette 54 can be replaced with a new one. A pivotal

cover 60 is pivotally mounted to the housing 32. The cover 60 can be opened to allow disposal and replacement of the cassette 54.

As shown in greater detail in FIGS. 2 and 3, the cassette 54 has an outer casing 62 that encloses test media 64. In the illustrated embodiment, the test media 64 is in the form of a continuous strip or tape. As will be appreciated, the test media 64 can be further segmented into discrete test sections. The casing 62 of the cassette 54 defines an unexposed test media supply portion 66, which stores unused test media 64, and an exposed test media storage portion 68, which stores used test media 64. Connecting together the unexposed 66 and exposed 68 media portions, an exposure/testing portion 70 is configured to allow the bodily fluid to be collected and tested on the test media 64. As shown, the testing portion 70 has outboard sidewall 72 and an opposite, inboard sidewall 74. On the outboard sidewall 72 of the cassette 54, the casing 62 defines an exposure opening 76 at which the test media 64 is exposed to the bodily fluid. Opposite the exposure opening 76, the inboard sidewall 74 of the casing 62 defines a test opening 78 at which the sensor 56 is able to analyze the bodily fluid collected on the test media 64. In the illustrated embodiment, the exposure 76 and test 78 openings are aligned with another. In other embodiments, openings 76 and 78 can be instead offset from one another. For instance, the testing opening 78 can be located closer towards the exposed media storage portion 68, as compared to exposure opening 76.

In the unexposed media storage portion 66 of the cassette 54, a supply reel 80 is rotatably mounted, and unused test media 64 is wrapped around the supply reel 80. Similarly, the exposed media storage portion 68 has a take-up reel 82 rotatably mounted inside. Test media 64 that has been exposed to the bodily fluid at the exposure opening 76 is wrapped around the take-up reel 82. It should be appreciated that in other embodiments, one or both of the reels 80, 82 can be omitted from the cassette 54. Both reels 80 and 82 define drive cavities 84 that can be engaged with drive members 86 in the sampling end portion 36 of the sampling device 30 (FIG. 4). As shown in FIGS. 2 and 4, the drive cavities 84 have notches 88 that mate with flanges 90 on the drive members 86 such that the drive members

86 are able to rotate the reels 80 and 82. To ensure that the used test media 54 is not removed from the exposed media storage portion 68 of the cassette 54, the take-up reel 82 has a geared portion 92 that engages a biased, cassette pawl 94 that permits the take-up reel 82 to rotate in only one direction. This ensures that the test media 64 can only be fed into exposed media storage portion 68 and not removed.

As shown in FIGS. 4 and 5, the sampling device 30 further incorporates an advancement or indexing device 96 that advances the test media 64 in the cassette 54 such that fresh test media 54 is available every time a bodily fluid sample is taken. In the illustrated embodiment, a mechanical type advancement device 96 is used to advance the test media 64. However, it should be appreciated that an electrical or a combination electro-mechanical type advancement device 96 may also be used. In FIG. 4, the advancement device 96 includes a rack member 98 that is attached to the piercing portion 34 of the housing 32. The rack member 98 extends from the piercing portion 34 and terminates proximal to take-up drive member 100. The take-up drive member 100 is constructed to engage and rotate the take-up reel 82 in the cassette 54. The rack member 98 has rack teeth 102 that engage take-up drive teeth 104 on the take-up drive member 100. To ensure that the take-up drive member 100 only rotates in one direction, the advancement device 96 has an advancement pawl 106 attached to the housing 32 and biased against the take-up drive teeth 104. As shown in FIG. 5, both teeth 102 and 104 are angled in such a manner to only firmly engage one another when rotating the take-up drive member 100 in a counter-clockwise fashion (from the perspective of FIG. 5). In the illustrated embodiment, only the take-up drive member 100 is powered, while supply drive member 108 is able to freely rotate. In other embodiments, both drive members 100 and 108 may be powered individually or together. For instance, when an electro-mechanical type advancement device 96 is used, both drive members 100 and 108 can be individually powered by separate electric motors.

Referring again to FIG. 1, the bodily fluid sampling device 30 further includes a test indicator 110, a display 112, at least one control button 114, and a

grip portion 116. In the illustrated embodiment, the grip portion 116 has ridges that help ensure the user has a firm grip on the sampling device 30. The test indicator 110 can either indicate the number of tests performed or the number of tests remaining on the current cassette 54. The housing 32 has an indicator window 118 through which the indicator 110 can be viewed. The display 112 is operatively coupled to the sensor 56 and displays readings from the sensor 56. The button 114 is used to control and enter information into the bodily fluid sampling device 30. In the illustrated embodiment, the indicator 110 and the display 112 are separate components. However, it should be appreciated that the indicator 110 can be incorporated into the display 112 to form a single unit.

A detailed view of a test indicator assembly 120, which moves the indicator 110, according to one embodiment of the present invention is illustrated in FIG. 5. As shown, the take-up drive member 100 has a gear 122 that engages an intermediate gear 124. The intermediate gear 124 engages an indicator gear 126 that is attached to the indicator 110. The indicator 110 has numbering 128, or other types of characters, that indicates the number of samples taken with the cassette 54 or the number of tests remaining on the cassette 54. As the take-up drive member 100 is rotated by the rack member 98, the intermediate gear 124 rotates, which in turn rotates the indicator. Although in the illustrated embodiment of the test indicator assembly 120 is mechanically driven, it should be appreciated that the indicator 110 can be operated in other manners, such as electronically.

In operation, the user presses opening 40 of the piercing portion 34 against the skin. The piercing portion 34 of the housing 32 retracts towards the sampling portion 36 exposing the piercing device 42 so as to pierce the skin. As the piercing portion 34 retracts, the rack member 98 rotates the take-up drive 100 in order to advance the test media 64 in the cassette 54 such that unused test media 64 is available for testing. Once the user creates a bodily fluid sample with the piercing device 42, the user places opening 58 over the bodily fluid sample. A portion of the bodily fluid sample travels via direct or capillary action to the unused test media 64 exposed at exposure opening 76 of the cassette 54. When a portion of the bodily fluid sample deposits on the test media 64, the sensor 56 determines the

amount of analyte material in the sample. The readings from the sensor 56 are shown on the display 112. During the next test, the cassette 54 is indexed in response to pressing the sampling device 30 against the skin so as to move the contaminated portion of the test media 64 into the storage portion 68 of the cassette 54. As should be appreciated, the sampling device 30 can be instead configured to advance the test media 64 after the bodily fluid sample has been collected or analyzed.

As should be appreciated, the cassette 54 allows a user to perform a number of tests without replacing the test media 64. Once the test media 64 has been completely used, the contaminated test media 64 in the cassette 54 can be safely discarded. In one embodiment, the cassette 54 allows the user to perform a number of tests within a range from about five (5) tests to about five-hundred (500) tests. In another embodiment, the cassette 54 is adapted to perform five (5) to fifty (50) tests before being replaced, and in a further embodiment, the cassette 54 is designed to perform around twenty-five (25) tests. With the above described configuration, the cassette 54 according to the present invention minimizes the amount of biohazard material generated after each test because a test strip does not have to be discarded after each test. Further, since test strips do not have to be individually inserted and removed during each test, the ease of use and convenience is improved with the cassette 54 according to the present invention. Moreover, the cassette 54 obviates the need for the user to carry a vile containing the test strips.

A cassette 54a according to another embodiment of the present invention is illustrated in FIG. 6. As shown, the cassette 54a has an outer cover 60a with an unexposed media supply portion 66a and an exposed media storage portion 68a. The exposed portion 68a of the cover 60a houses a take-up reel 82a, while the unexposed portion 66a houses a supply reel 80a. The test media 64a extends between and is wrapped around both the supply reel 80a and the take-up reel 82a. In the illustrated embodiment, the test media 64a has a cover tape 130 that covers a test tape 132. The cover tape 130 provides an airtight seal over the test tape 132 in order to preserve test chemicals on the test tape 132 while the sampling device 30

is not in use. As illustrated, the cassette 54a further includes a peel tab 134, a cover reel 136 and guides 138 to guide the test media 64a between reels 80a and 82a. The peel tab 134 along with the cover reel 136 are configured to peel the cover tape 130 from the test tape 132. To synchronize rotation of the supply reel 80a and the cover reel 136, the supply reel 80a and the cover reel 136 respectively have a supply gear 140 and a cover gear 142 that are intermeshed with one another. In another embodiment, the rotation of the cover reel 136 is synchronized with the take-up reel 82a.

During use, as the take-up reel 82a is indexed by the sampling device 30, both the supply reel 80a and the cover reel 136 are rotated in unison through gears 140 and 142. As the cover reel 136 rotates, the tension formed on the cover tape 130 between the cover reel 136 and the peel tab 134 causes the cover tape 130 to be pulled from the test tape 132 at the peel tab 134. The peeled cover tape 130 is wrapped around and stored on the cover reel 136. After the cover tape 130 is removed, the test tape 132 is exposed to the bodily fluid sample at an exposure opening 76a formed in the cover 60a. The now exposed test tape 132 can be tested at testing opening 78a that is incorporated into the exposure opening 76a. During the next index of the cassette 54a, the used test tape 132 is wrapped around and stored on the take-up reel 82a.

A bodily fluid sampling device 144 according to another embodiment of the present invention is illustrated in FIG. 7. The sampling device 144 includes a cassette 54b and a pivot arm 146 with a pivot end 148 pivotally mounted to the cassette 54b. Opposite the pivot end 148, at free end 150, the pivot arm 146 is coupled to piercing device 42. A spring 152 mounted between the cassette 54b and the pivot arm 146 biases the free end 150 of the pivot arm 146 to move towards the cassette 54b in the direction indicated by arrow A in FIG. 7. A release mechanism 154 is coupled to the free end 150 of the pivot arm 146 in order to bias the piercing device 42 away from the cassette 54b. The cassette 54b includes a supply reel 80, a take-up reel 82 and a test media 64b extending between and wrapped around both reels 80, 82. As illustrated, housing 156 of the sampling device 144 defines a sample opening 158 through which the bodily fluid sample is collected. The test

media 64b of the cassette 54 is positioned over the sample opening 158 between the opening 158 and the piercing device 42.

As shown in further detail in FIGS. 8, 9 and 10, the test media 64b in this embodiment includes a number of test pads 160 spaced apart from one another
5 along the test media 64b. In one embodiment, the test pads 160 contain chemicals reactive to specific constituents contained in the bodily fluid. In one form, the test pad 160 includes a chemistry pad available in an AT LAST™ Blood Glucose System available from Amira Medical located in Scotts Valley, California. In another embodiment, the bodily fluid sample is collected on the test pad 160 for
10 electrical and/or optical analysis. Over each test pad 160, the test media 64b has a blister pack 162 that is used to draw the bodily fluid through capillary action onto the test pad 160. During indexing of the test media 64b, a capillary opening 163 (FIG. 8), such as a slit or hole, is cut or pierced into the blister pack 162 by a cutting device, such as razor, in the fluid sampling device 144. In the illustrated
15 embodiment, the opening 163 is in the form of a slit. The capillary slit 163 is used to draw the bodily fluid into the blister pack 162 through capillary action. In the illustrated embodiment the blister pack 162 has a circular shape that fits inside the rectangularly shaped test pad 160 such that portions of the test pad 160 extend past the blister pack 164. In one form, the blister pack 164 is a plastic film covering the
20 test pad 160 and attached to the test media 64b through an adhesive and/or heat sealing. Moreover, in one embodiment, the test media 64b is transparent or semitransparent to allow optical analysis of the bodily fluid. As illustrated in FIGS. 9 and 10 each blister pack 162 has a convex surface 164 that aids in drawing the fluid up to the test pad 160 through the slit 163 via capillary action. To be near
25 the skin in order to collect bodily fluid, both the test pad 160 and the blister pack 162 are positioned on the outboard side 170 of the test media 64b. In another embodiment, the blister pack 162 is omitted such that the bodily fluid directly contacts the test pad 160 during collection of the bodily fluid. Between each test pad 160, the test media 64b defines a piercing device hole or throughway 166. The
30 piercing device throughway 166 extends from inboard side 168 to outboard side 170 of the test media 64b. The throughway 166 is sized such that the piercing

device 42 is able to extend through the test media 64b in order to pierce the skin. In another embodiment, the test media 64b is designed to be pierced by the piercing device 42 such that the throughway 166 is not required.

During testing, the user places sample opening 158 of the sampling device 144 against his or her skin 172 (FIGS. 7 and 10). Next, the user disengages the release 154 such that the piercing device 42 on the pivotal arm 146 moves toward the test media 64b. As the pivot arm 146 rotates, the piercing device 42 extends through the throughway 166 and pierces the skin 172 (FIG. 10). After piercing the skin 172, the piercing device 42 retracts away from the skin 172 and out of the throughway 166. In one embodiment, the piercing device 42 is retracted through recoil of a firing spring that is used to initially advance the piercing device 42 to lance the skin 172. At the site where the skin 172 was pierced, the bodily fluid collects and is drawn up by the slit 163 in the blister pack 162 to the test pad 160 via capillary action. To store used test media 64b on the take-up reel 82, the test media 64b in the cassette 54b can be advanced mechanically or manually before or after a test is performed. In one embodiment, the test media 64b in the cassette automatically advances when the pivot arm 146 swings toward the cassette 54b. In another embodiment, the test media 64b is advanced manually after the sample has been collected and tested.

A bodily fluid sampling device 174 according to another embodiment of the present invention is illustrated in FIG. 11. The sampling device 174 has a piercing device 42 coupled to a pivot arm 146 that is pivotally coupled to a trigger mechanism 176. Both the pivot arm 146 and the trigger mechanism 176 of the sampling device 174 are pivotally coupled to a housing 178. The housing 178 defines a sample opening 158. The pivot arm 146 and the piercing device 42 are positioned within the housing 178 such that the piercing device 42 is able to swing through the opening 158 and pierce the skin. The sampling device 174 further includes a cassette-sensor assembly 180 pivotally mounted to the housing 178 through a swing arm 182. As shown, the cassette-sensor assembly 180 includes a cassette 54 and a sensor 56. The sensor 56 is mounted proximal to and in a fixed relationship with the cassette 54 through mounting arms 184. The swing arm 182

of the cassette-sensor assembly 180 can be moved by a number ways. In one embodiment, the swing arm 182 is actuated through a mechanical linkage with the trigger mechanism 176, and in another embodiment, the swing arm 182 is moved by an electric motor.

5 To take and test a bodily fluid sample, the user presses the sample opening 158 against the skin of the user. The user then cocks the trigger mechanism 176 and releases the trigger mechanism 176 in order to swing the piercing device 42 through the sample opening 158 to pierce the skin of the user. Afterwards, the piercing device 42 retracts back into the housing 178 as a sample of the bodily
10 fluid, such as blood, collects on the skin. In one form, the piercing device 42 is retracted by the recoil of a firing spring that is initially used to lance the skin. To collect and test the bodily fluid sample, the swing arm 182 swings the cassette sensor assembly 180 over the opening 158. After the sample is deposited on the test media 64 in the cassette 54, the sensor 56 analyzes the collected sample. In
15 one form, the sensor 56 is an optical type sensor that analyzes the optical properties of the sample. In another form, the sensor 56 analyzes the electrical properties of the sample.

As mentioned above, the sensor 56 can analyze the bodily fluid sample by using a number of techniques. In one embodiment, the sensor 56 analyzes the
20 electrochemical properties of the sample. In another embodiment that is illustrated in FIG. 12, the sensor 56 includes an optical sensor system 186 that remotely detects the optical properties of the sampled bodily fluid. The optical sensor system 186 includes a remotely located light source/detector 188, which can be located inside or outside of the bodily fluid sampling device. The light
25 source/detector 188 employs components suitable for emitting light and for determining the amount and/or frequency of reflected light. By way of nonlimiting example, the light source/detector 188 can include a light emitting diode (LED), a photodiode and the like. With such a construction, the optical sensor system 186 according to the present invention allows for more compact sampling device and
30 cassette designs. As shown, a pair of fiber optic cables 190 are coupled to the light source/detector 188. The fiber optic cables 190 include a transmission cable 192

and a detection cable 194. The fiber optic cables 190 extend from the light source/detector 188 to a test area 196 that is proximal the test media 64. In the test area 196, the transmission cable 192 is coupled to an emitter 198 that is adapted to emit light, and the detection cable 194 is coupled to a detector 200 that is adapted to receive light.

During testing, after the bodily fluid sample has been placed on the test media 64, the light source/detector 188 emits light from the emitter 198 via transmission cable 192. The light emitted from the emitter 198 is reflected off the bodily fluid sample on the test media 64, and the reflected light is detected by the light source/detector 188 via the detector 200. The light/source detector 188 analyzes the amount and/or frequency of the light reflected from the bodily fluid sample in order to determine the amount of analyte in the sample. As used herein and in conventional fashion, reference to analysis of the bodily fluid also includes analysis of the results of a reaction of a selected reagent with the bodily fluid.

A bodily fluid testing system 202 that can be integrated into a sampling device according to the present invention is illustrated in FIG. 13. The testing system 202 includes a vacuum assembly 204, a piercing assembly 206, a sensor 56, and test media 64c. In the illustrated embodiment, the test media 64c is not housed in a cassette case. Rather, the test media 64c is wrapped around and extends between supply reel 80 and take-up reel 82. It should be appreciated that the test media 64c can be encased in a cassette case. As shown, the test media 64c has an inboard side 208 and an opposite, outboard side 210. The vacuum assembly 204, the piercing assembly 206 and the sensor 56 are positioned along the test media 64c between the supply reel 80 and the take-up reel 82. In particular, both the vacuum assembly 204 and the sensor 56 are positioned on the inboard side 208, with the sensor 56 positioned between the take-up reel 82 and the vacuum assembly 204. The piercing assembly 206 is disposed opposite the vacuum assembly 204 on the outboard side 210 of the test media 64c.

The vacuum assembly 204 is adapted to generate a vacuum in order to draw a bodily fluid sample onto and/or into the test media 64c. The vacuum assembly 204 can include, but is not limited to, a pre-charge vacuum device, an

electromagnetic diaphragm vacuum device and/or a mechanical vacuum device, to name a few. In the illustrated embodiment, the vacuum assembly 204 has a body 212 that defines a vacuum cavity 214. Near the test media 64c, the body 212 defines a vacuum port 216 that opens into the vacuum cavity 214. A piston 218 is
5 slidably received in the vacuum cavity 214. Solenoids 220 are used to actuate the piston 218 in order to form a vacuum in the vacuum cavity 214.

As shown in FIG. 13, the piercing assembly 206 includes a piercing device 42a, a holder 222, which holds the piercing device 42a, and a protective cover 224. In the illustrated embodiment, the piercing device 42a has a distal tip 226 adapted
10 to pierce the skin of the user and a proximal tip 228. As depicted in FIG. 15, the piercing device 42a defines a cavity 227 that extends from the distal tip 226 to the proximal tip 228. The cavity 227 transports bodily fluid from the user to the test media 64c. Referring again to FIG. 13, the protective cover 224 covers the distal tip 226 of the piercing device 42a so as to prevent a person from being accidentally
15 cut with the piercing device 42a. The holder 222 includes a coil spring 230 wrapped around the piercing device 42a such that the piercing device 42a is able to be removed and replaced with another piercing device 42a. As shown, the holder 222 has a hollow, inner holder member 232 that is surrounded by an outer holder member 234. The piercing device 42a along with the coil spring 230 are received
20 inside the inner holder member 232. To prevent over-penetration of the proximal tip 228 of the piercing device 42a into the test media 64c during testing, the inner holder member 232 has a stop ridge 236 that engages the piercing device 42a. The holder 222 further includes a collapsible, biasing member 238 that normally biases the piercing device 42a away from the test media 64c. When the holder 222 is
25 pressed against the skin during piercing, the biasing member 238 collapses such that the proximal tip 228 of the piercing device 42a is able to pierce the test media 64c.

As illustrated in FIGS. 14 and 15, the test media 64c has a number of testing sections 240 that are adapted to collect separate bodily fluid samples. Each
30 testing section 240 has a test pad 242 positioned between a seal membrane 244 and a vacuum passageway 246 that is defined in the test media 64c. In one

embodiment, the test pad 242 is embedded with chemicals that are reactive with specific bodily fluid constituents for testing purposes. In another embodiment, the test pad 242 is adapted to collect and absorb the bodily fluid sample for analysis by the sensor 56. On the outboard side 210 of the test media 64c, the seal membrane 244 seals over the test membrane 242. On the inboard side 208, the vacuum passageway 246 is adapted to align with the vacuum port 216 of the vacuum assembly 204 such that the vacuum assembly 204 is able to form a vacuum (an area of low pressure) in the vacuum passageway 246 and around the test pad 242. The seal 244 is made of suitable material that allows the vacuum to be maintained around the test pad 242, while at the same time being able to be punctured by the piercing device 42a (FIG. 15). The seal 244 may be formed from various types of sealing materials, such as rubber and/or silicone, to name a few.

As mentioned above, to test a bodily fluid sample, the user presses the holder 222 against the skin in order to pierce the skin with the piercing device 42a. As piercing device 42a pierces the skin, the biasing member 238 collapses to allow the proximal tip 228 to puncture the test media 64c. As shown in FIG. 15, the seal 244 is punctured by and seals around the proximal tip 228. The vacuum assembly 204 forms a vacuum in the vacuum passageway in order to draw the bodily fluid sample onto the test pad 242. Once the sample is collected on the test pad 242, the holder 22 is removed from the skin and the vacuum assembly 204 ceases operation. The test pad 242 is then indexed proximal to the sensor 56 for analysis.

While the invention has been illustrated and described in detail in the drawings and foregoing description, the same is to be considered as illustrative and not restrictive in character, it being understood that only the preferred embodiment has been shown and described and that all changes and modifications that come within the spirit of the invention are desired to be protected.

What is claimed is:

- 5 1. A bodily fluid sampling device, comprising:
 a test media cassette that includes a test media tape on which bodily fluid
 from an incision is collected, a supply portion from which the test media tape is
 supplied and a storage portion in which the test media tape is stored; and
 means for expressing the bodily fluid from the incision.
- 10 2. The sampling device of claim 1, wherein said means for expressing
 the bodily fluid includes a vacuum assembly operable to draw the bodily fluid
 from the incision via suction.
- 15 3. The sampling device of claim 2, further comprising:
 a piercing device to pierce the skin, said piercing device defining a cavity
 that is operatively coupled to said vacuum assembly to draw the bodily fluid from
 the incision to said test media tape.
- 20 4. The sampling device of claim 3, wherein said test media tape
 includes separate test sections, each of said test sections including a vacuum
 passageway defined in said test media tape and a seal membrane, said seal
 membrane being adapted to be pierced and seal around said piercing device when
 the bodily fluid is collected, each of said test sections further including a test pad
25 positioned between said vacuum passageway and said seal membrane, said test
 pad being adapted to collect the bodily fluid.
- 30 5. The sampling device of claim 4, further comprising:
 a sensor positioned proximal to said test media tape to analyze the bodily
 fluid.
6. The sampling device of claim 1, further comprising:
 a piercing device to pierce the skin.

7. The sampling device of claim 6, further comprising:
a sensor positioned proximal to said test media tape to analyze the bodily
5 fluid.

8. The sampling device of claim 1, further comprising:
a sensor positioned proximal to said test media tape to analyze the bodily
fluid.

9. The sampling device of claim 8, wherein said sensor includes an
optical sensor.

10. The bodily fluid sampling device of claim 1, wherein:
15 said supply portion includes a supply reel around which an
uncontaminated section of said test media tape is wound; and
said storage portion includes a storage reel around which a contaminated
section of said test media tape is wound.

20 11. A bodily fluid sampling device, comprising:
a test media cassette including
a test media tape configured to collect the bodily fluid,
a supply portion configured to store an uncontaminated section of
the test media tape that is uncontaminated with the bodily fluid, and
25 a storage portion configured to store a contaminated section of the
test media tape that is contaminated with the bodily fluid; and
a vacuum assembly positioned proximal the test media cassette to draw the
bodily fluid from the incision via suction for collection by the test media tape.

30 12. The sampling device of claim 11, further comprising:
a piercing device to pierce the skin, the piercing device defining a cavity
that is operatively coupled to the vacuum assembly to draw the bodily fluid from
the incision to the test media tape.

13. The sampling device of claim 12, wherein the test media tape includes separate test sections, each of the test sections including a vacuum passageway defined in the test media tape and a seal membrane, the seal membrane being adapted to be pierced and seal around the piercing device when the bodily fluid is collected, each of the test sections further including a test pad positioned between the vacuum passageway and the seal membrane, the test pad being adapted to collect the bodily fluid.

14. The sampling device of claim 13, further comprising:
a sensor positioned proximal to the test media tape to analyze the bodily fluid.

15. A test media cassette, comprising:
a test media tape on which bodily fluid from an incision is collected;
a cover tape covering the test media tape to preserve the test media tape;
a supply reel from which the test media tape is supplied; and
a storage reel around which the test media tape is stored.

16. The test media cassette of claim 15, further comprising:
a cover reel attached to the cover tape, the cover reel being adapted to peel the cover tape from the test media tape before exposure to the bodily fluid.

17. The test media cassette of claim 15, further comprising:
a cover including a supply portion in which the supply reel is rotatably mounted, a storage portion in which the storage reel is rotatably mounted, the cover defining an exposure opening along the test media tape at which the test media tape is exposed to the bodily fluid.

18. A bodily fluid sampling device, comprising:
a test media tape on which bodily fluid from an incision is collected,
wherein the test media tape includes

a test pad containing a reagent for testing the bodily fluid, and

5 a blister pack positioned proximal to the test pad, the blister pack
having a raised surface adapted to draw the bodily fluid to the test pad
through capillary action;
a supply portion from which the test media tape is supplied; and
a storage portion in which the test media tape is stored.

10 19. The sampling device of claim 18, further comprising:
a piercing device adapted to pierce skin; and
the test media tape defining a throughway to allow passage of the piercing
device through the test media tape during piercing of the skin.

15 20. A method, comprising:
expressing bodily fluid from an incision in skin with a sampling device
that includes a test media cassette, wherein the test media cassette includes a test
media tape, a supply portion from which the test media tape is supplied and a
storage portion in which the test media tape is stored; and
20 collecting the bodily fluid from the incision with the test media tape of the
test media cassette.

21. The method of claim 20, wherein said expressing includes drawing
the bodily fluid from the incision via suction.

25 22. The method of claim 21, further comprising:
wherein the sampling device includes a piercing device that has a cavity
and a vacuum assembly to create suction in the cavity;
forming the incision in the skin with the piercing device;
wherein said drawing the bodily fluid from the incision includes creating
30 suction in the cavity of the piercing device with the vacuum assembly; and
wherein said collecting includes transporting the bodily fluid through the
cavity from the incision to the test strip.

23. The method of claim 22, further comprising:
AMENDED SHEET

25/1

wherein the test media tape defines a passageway, includes a seal
membrane adapted to seal around a piercing device and includes a test pad
5 positioned between the passageway and the seal membrane; and
puncturing the seal membrane of the test media tape with the piercing
device.

24. The method of claim 20, further comprising:
10 advancing the test media tape to store a portion of the test media
contaminated with the bodily fluid in the storage portion.

25. The method of claim 20, further comprising:
15 wherein the sampling device includes a piercing device; and
forming the incision in the skin with the piercing device.

26. The method of claim 20, further comprising analyzing the fluid
20 collected on the test media strip with a sensor in the sampling device.

27. The method of claim 26, wherein the sensor includes an optical
sensor and said analyzing includes optically testing the fluid.

28. A method, comprising:
25 contacting a sampling device against skin, wherein the sampling device
includes a piercing device and a test media cassette moveably coupled to the
sampling device, wherein the test media cassette includes a test media tape, a
supply portion from which the test media tape is supplied and a storage portion in
which the test media tape is stored;

30 piercing the skin with the piercing device to form an incision in the skin
while the sampling device remain in contact with the skin; and
moving the test media cassette towards the incision to collect bodily fluid
from the incision with the test media tape while the sampling device remain in
contact with the skin.

AMENDED SHEET

25/2

29. The method of claim 28, wherein:
the test media cassette is pivotally mounted in the sampling device; and
5 said moving includes pivoting the test media cassette towards the incision
to collect the bodily fluid from the incision.

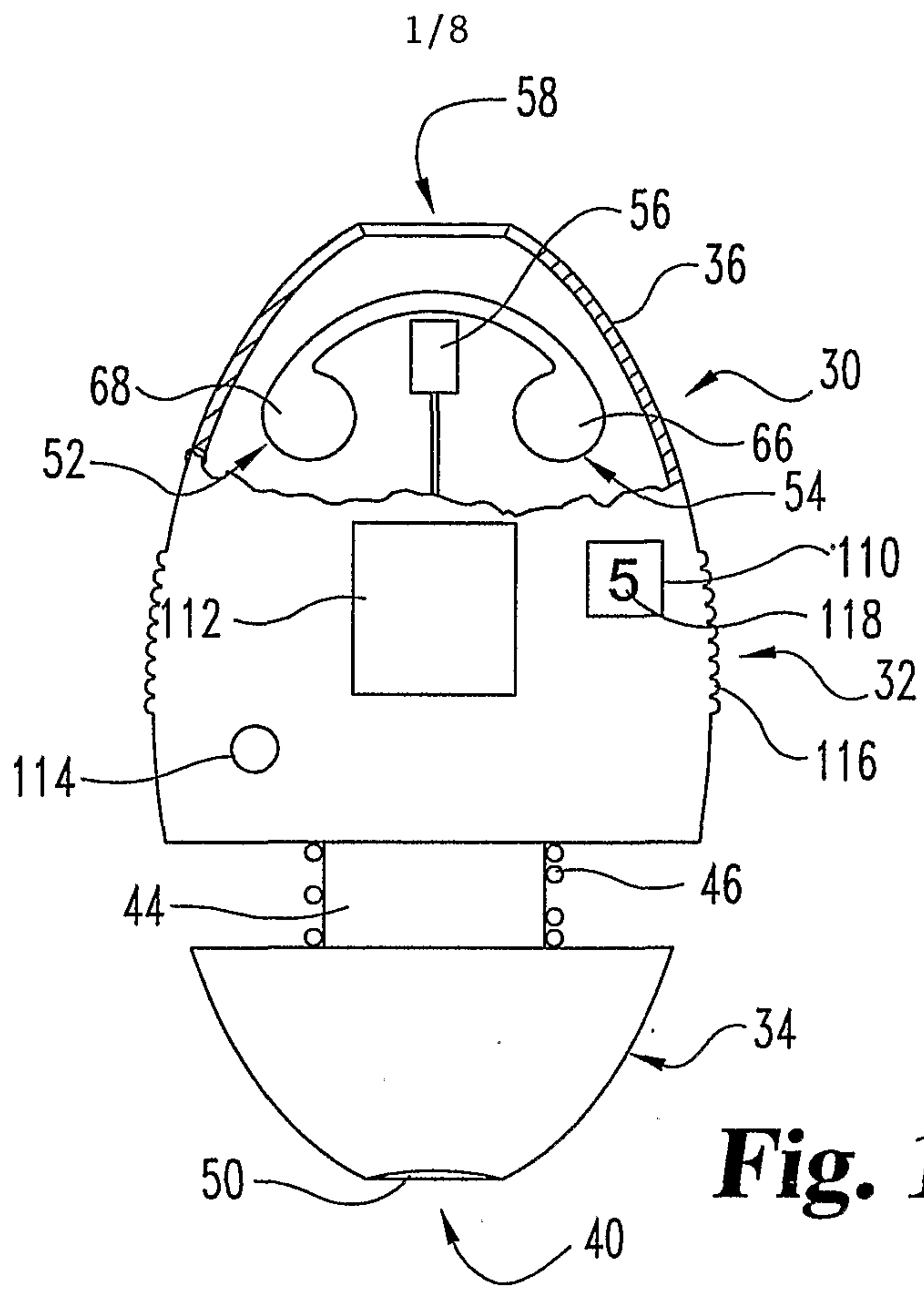

Fig. 1

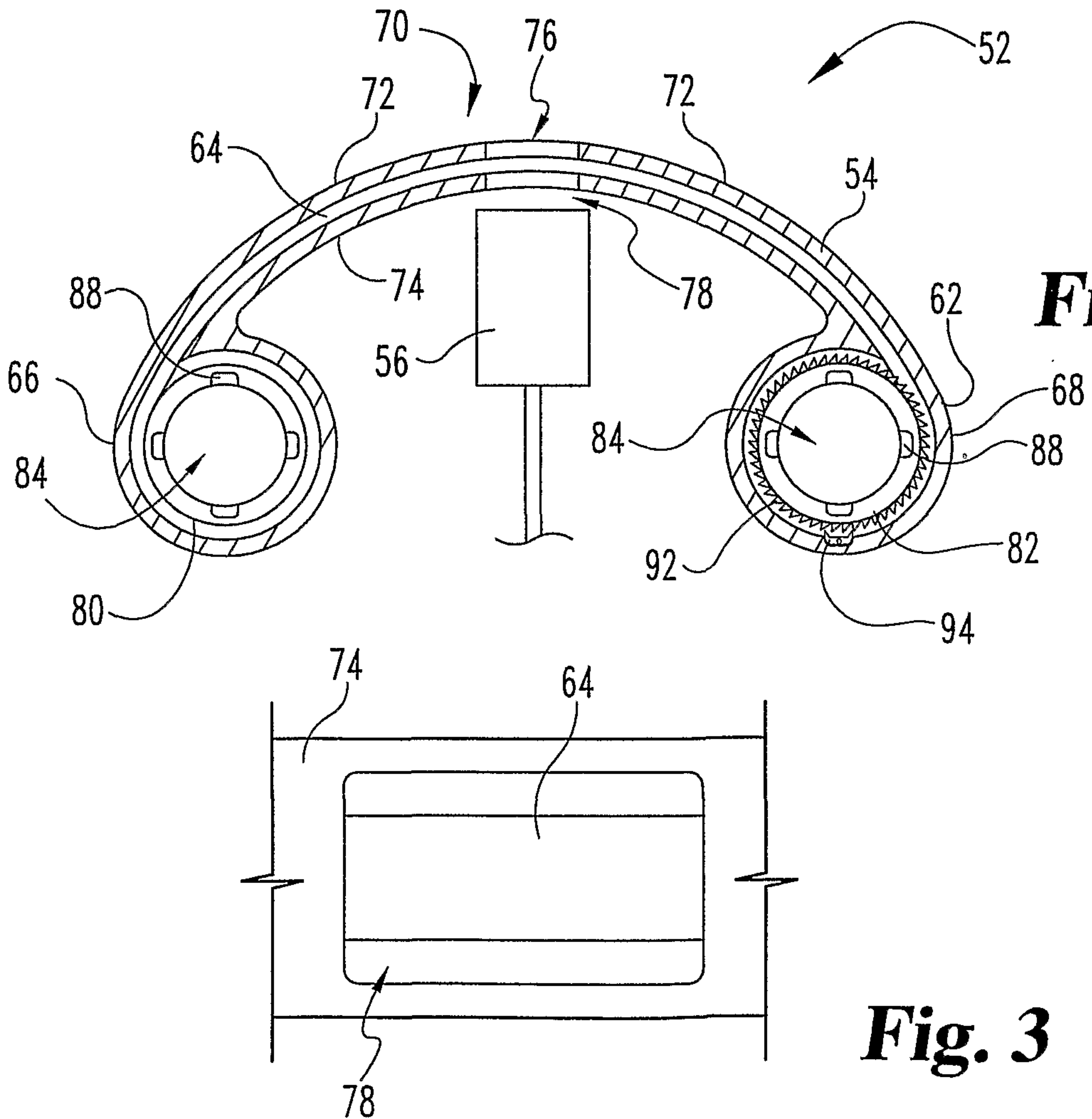

Fig. 2

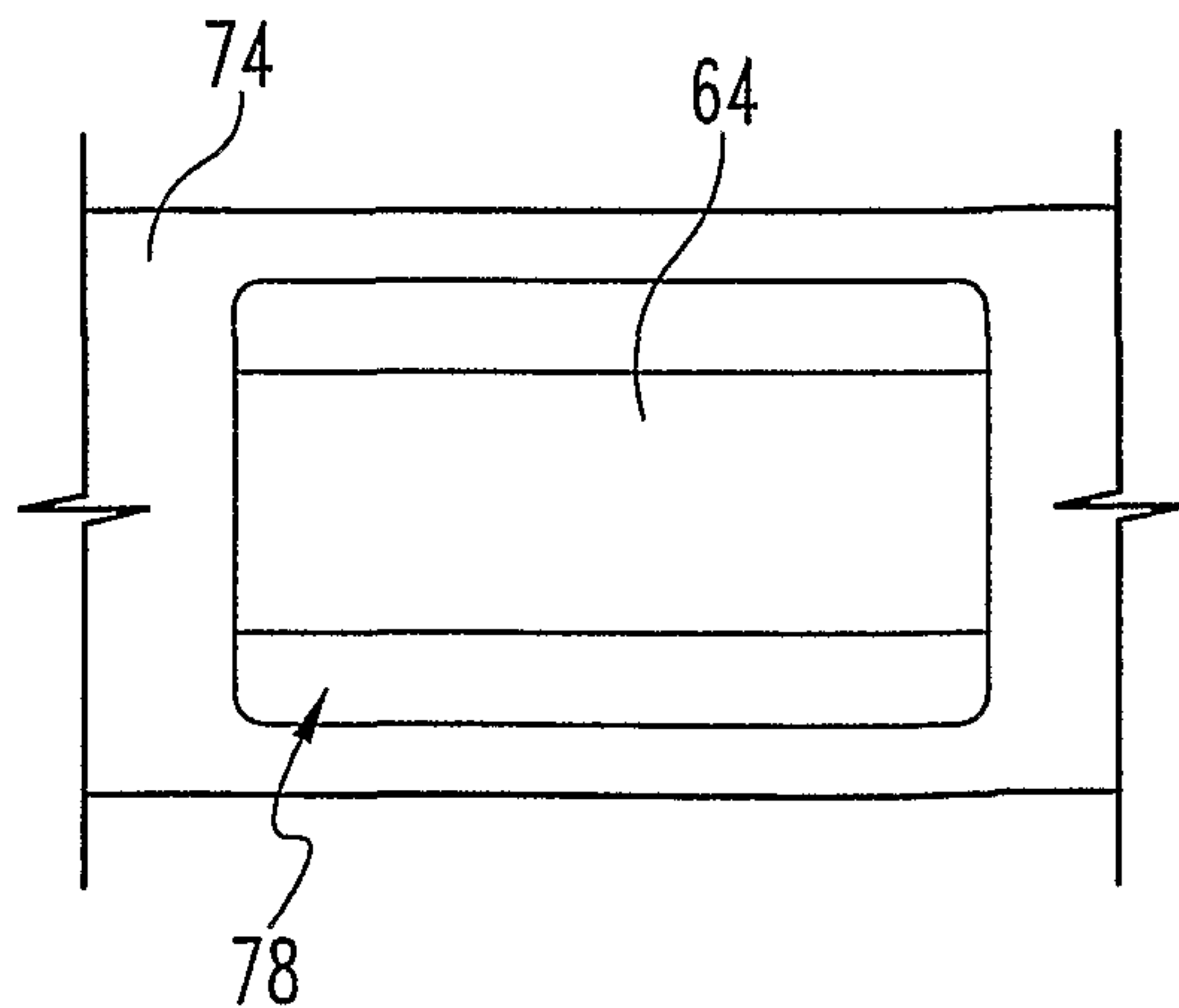

Fig. 3

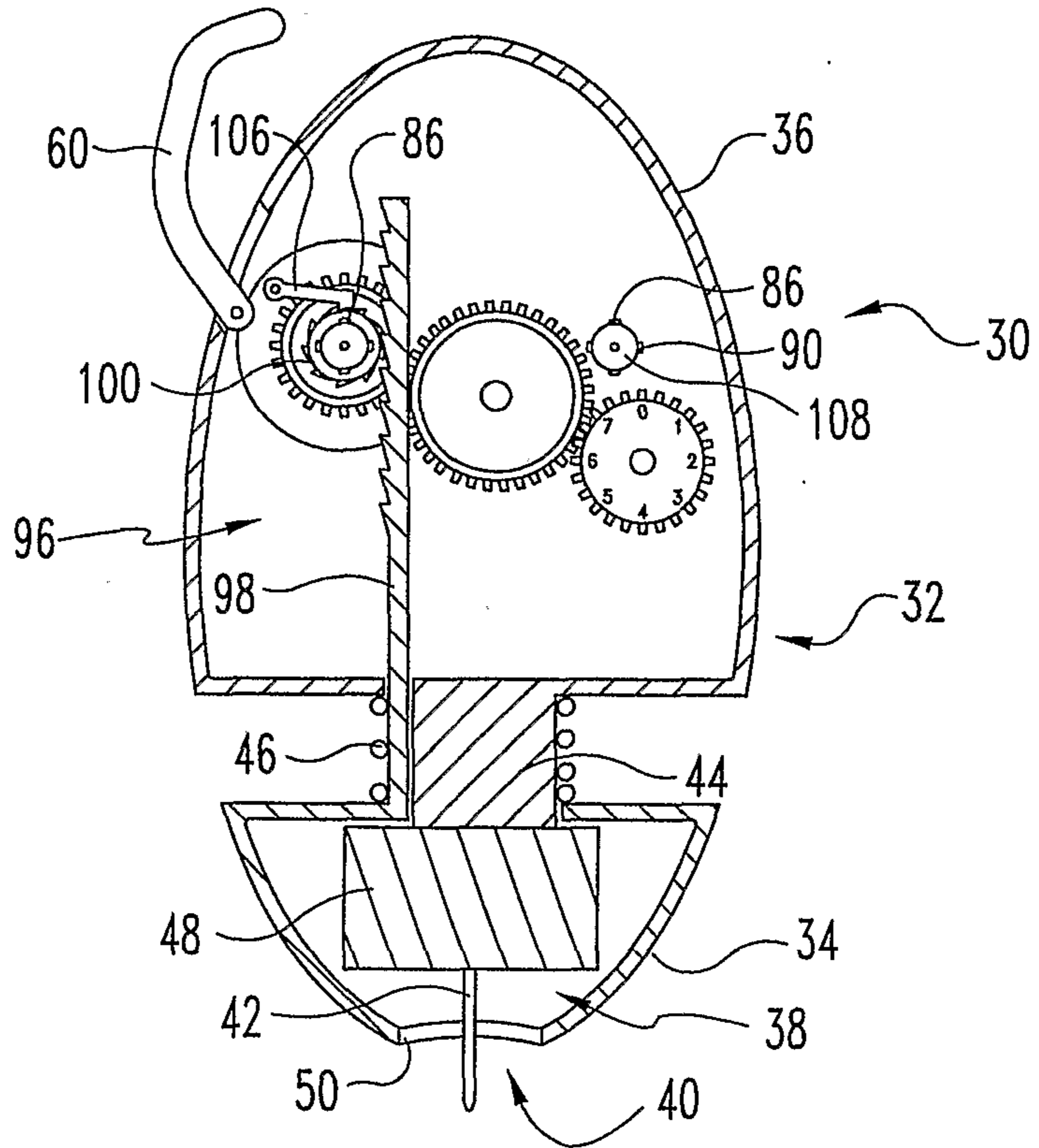

Fig. 4

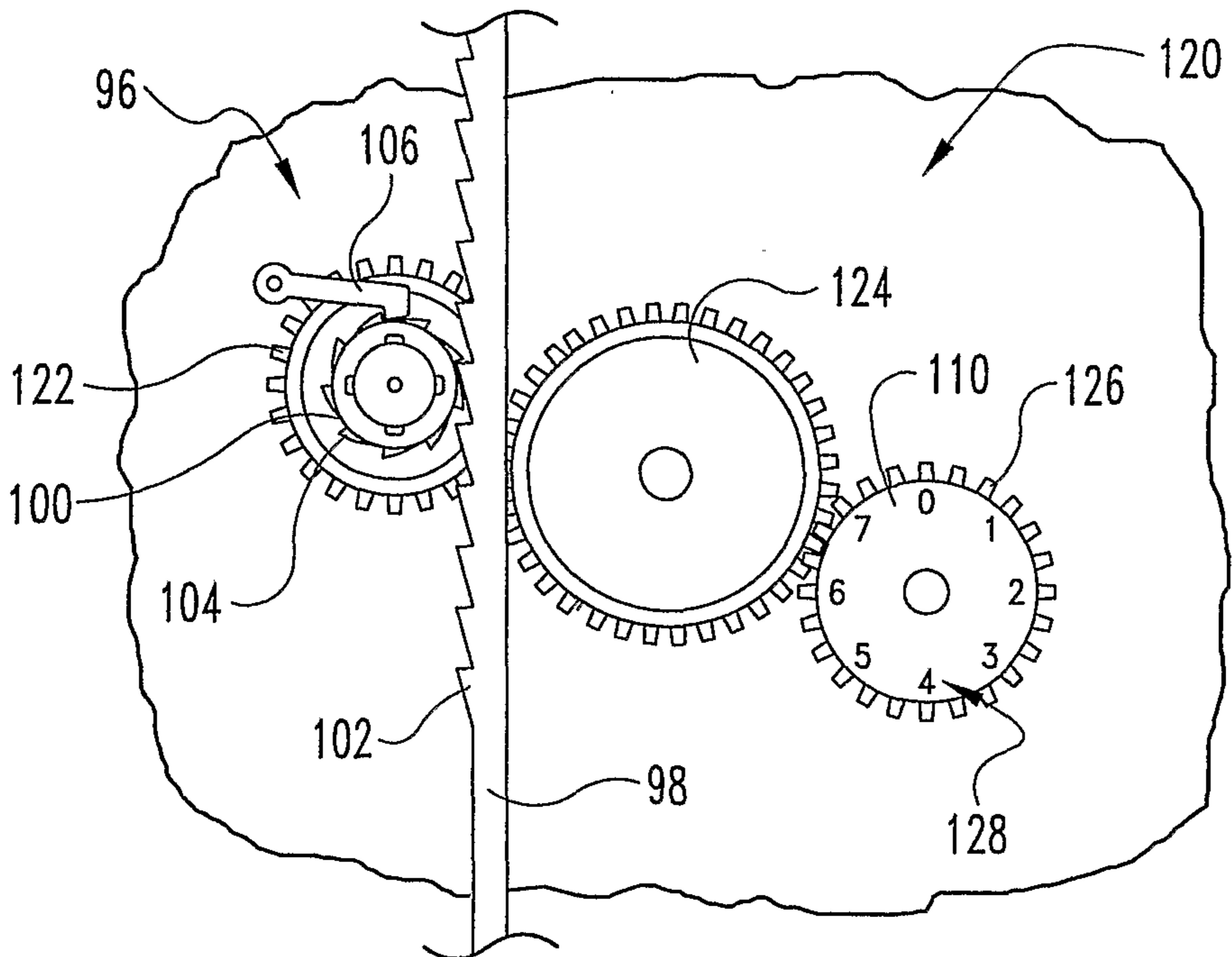

Fig. 5

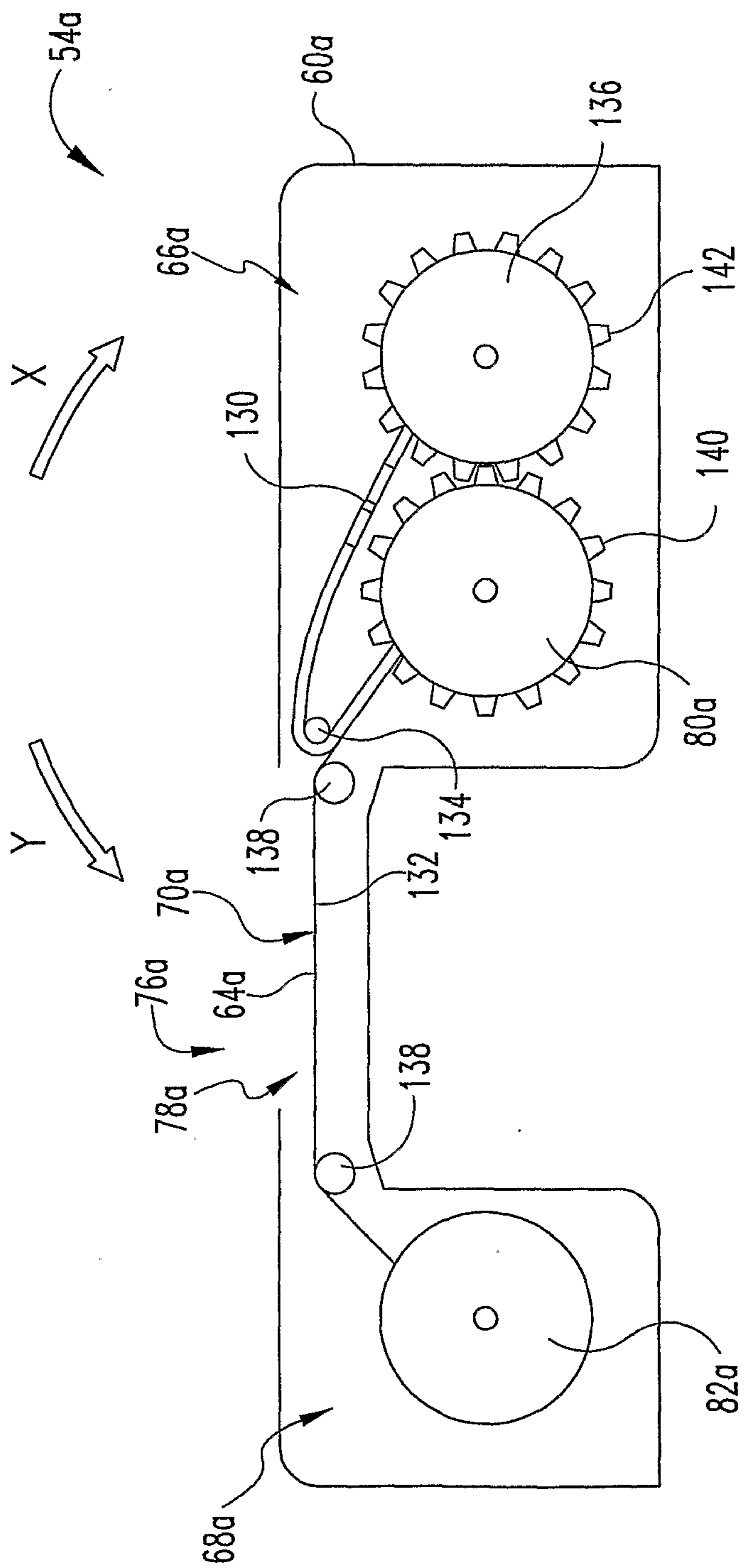

Fig. 6

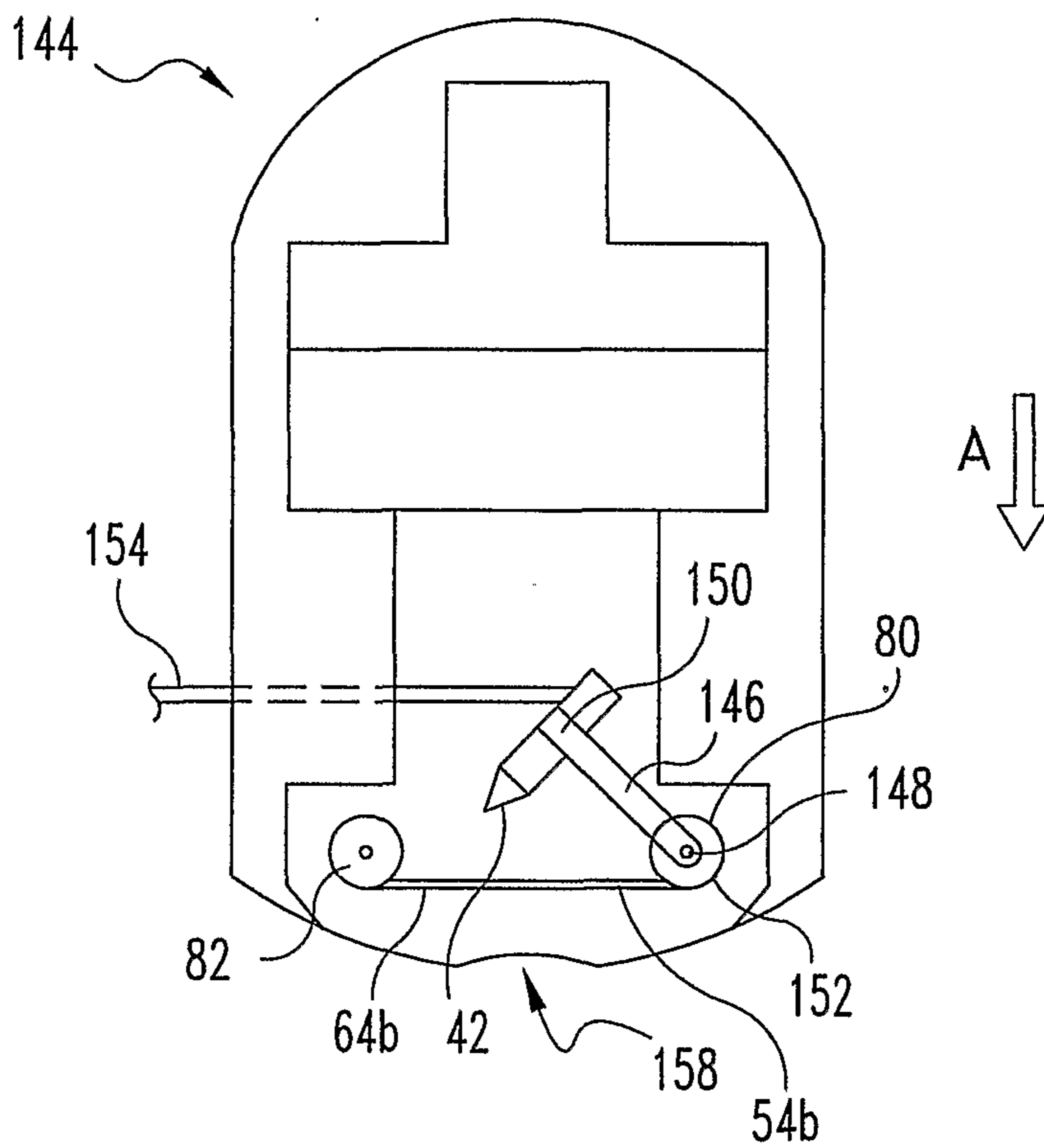

Fig. 7

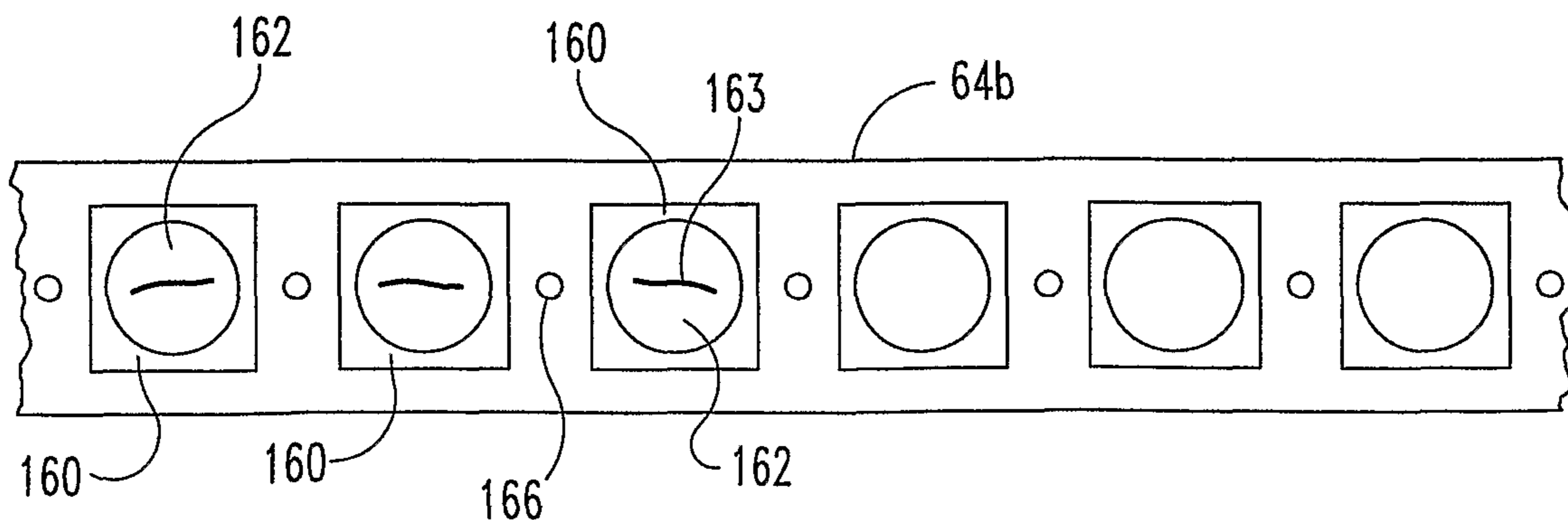

Fig. 8

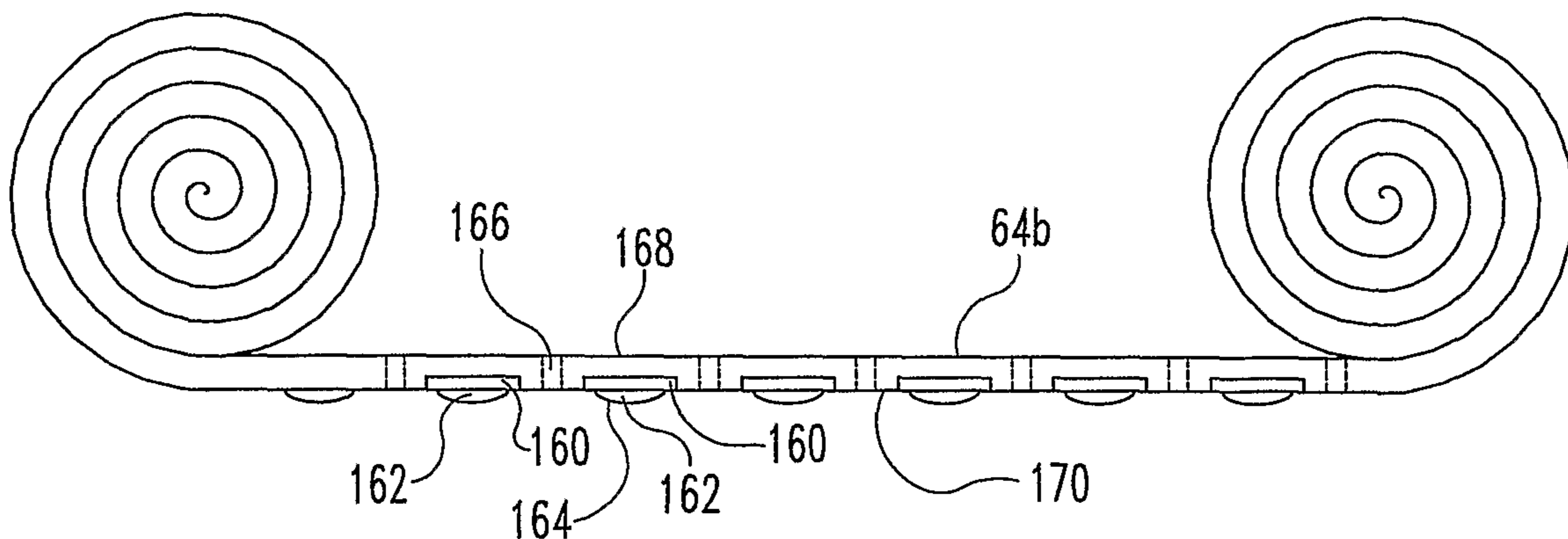

Fig. 9

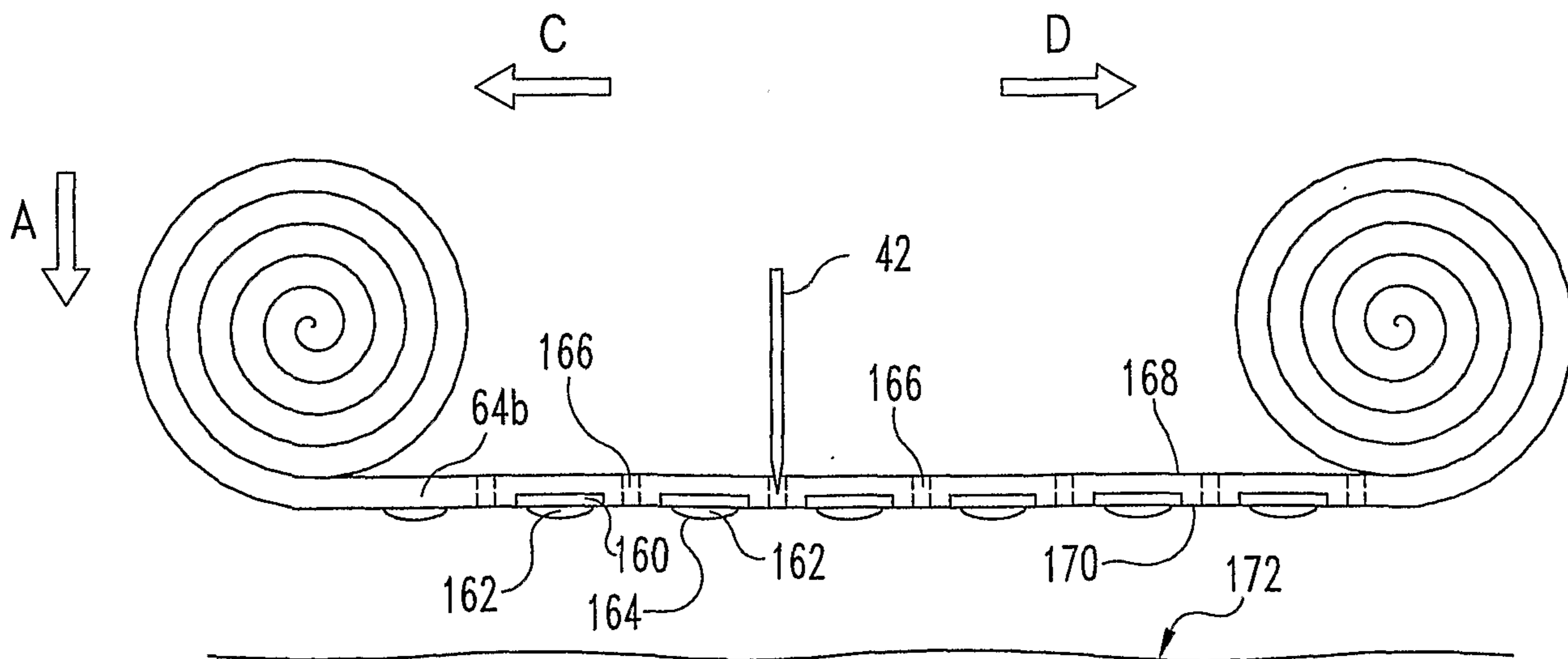

Fig. 10

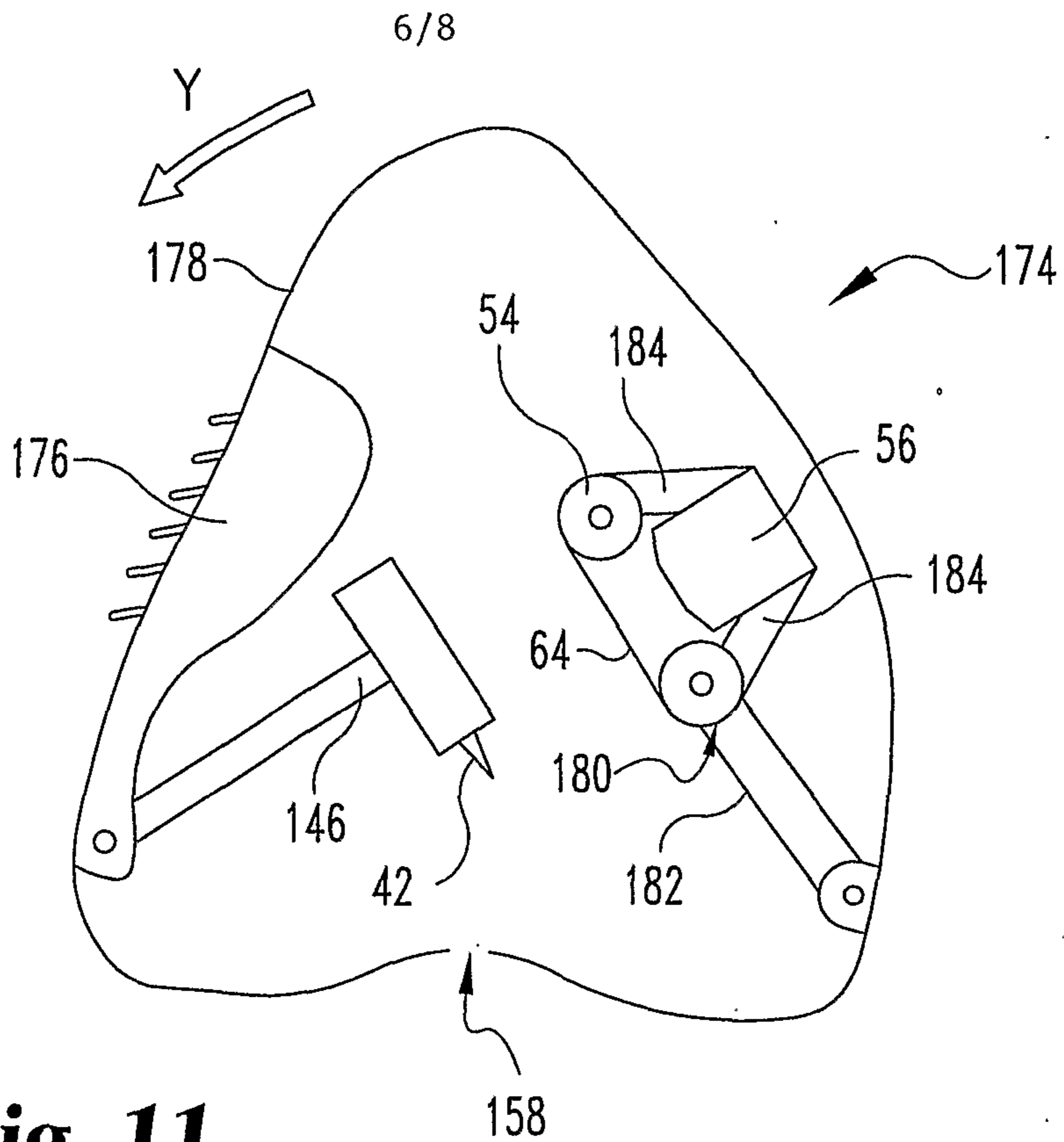

Fig. 11

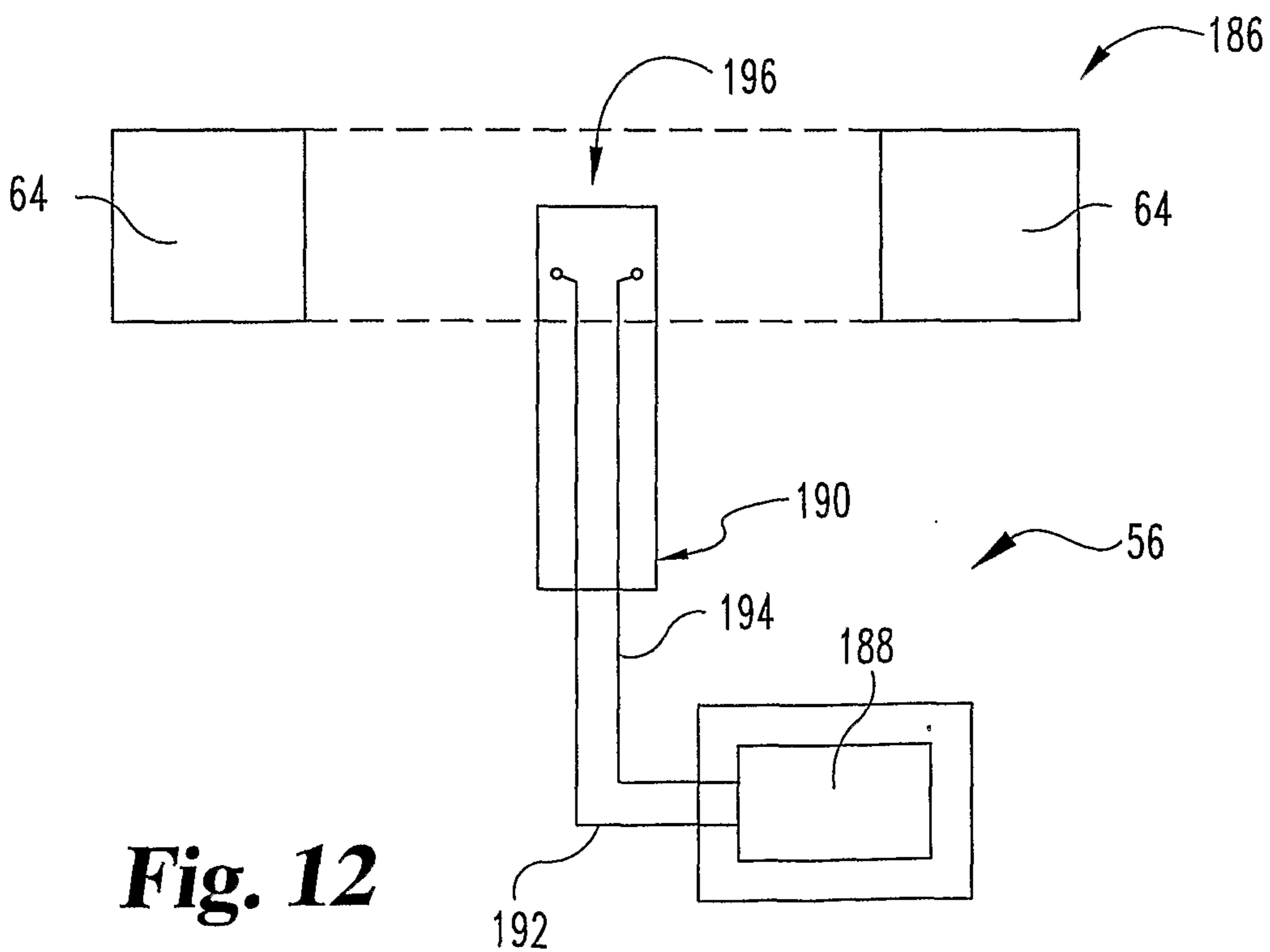

Fig. 12

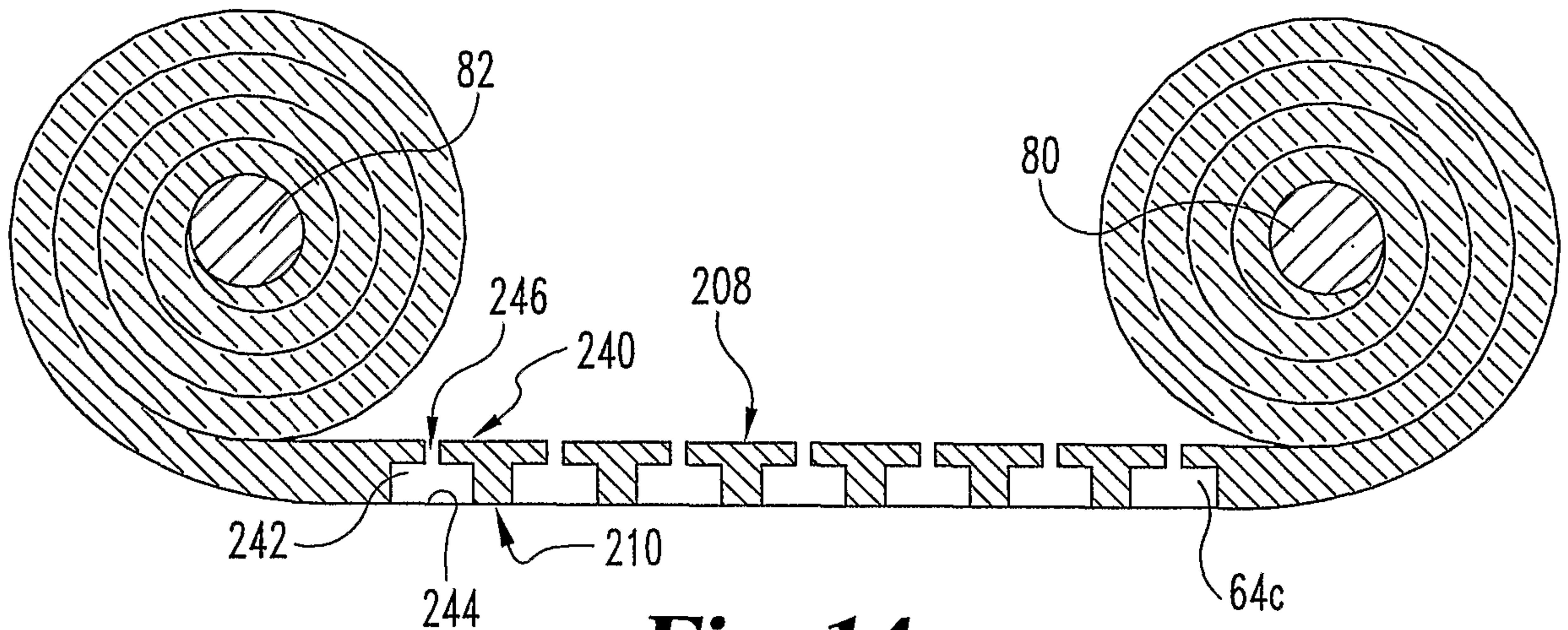

Fig. 14

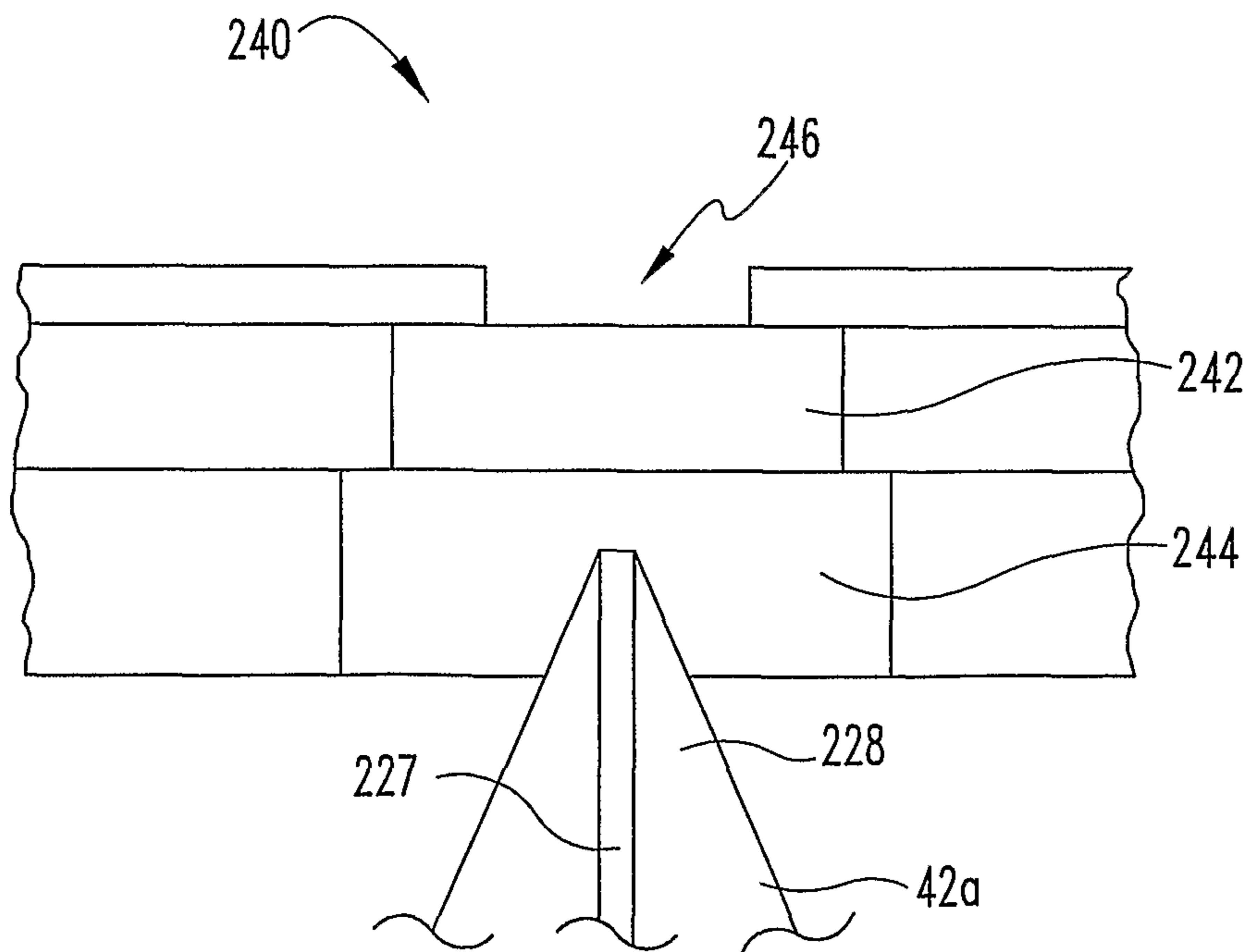

Fig. 15

