

W. P. WARD.
 PROTRACTOR.
 APPLICATION FILED MAR. 8, 1913.

1,082,377.

Patented Dec. 23, 1913.

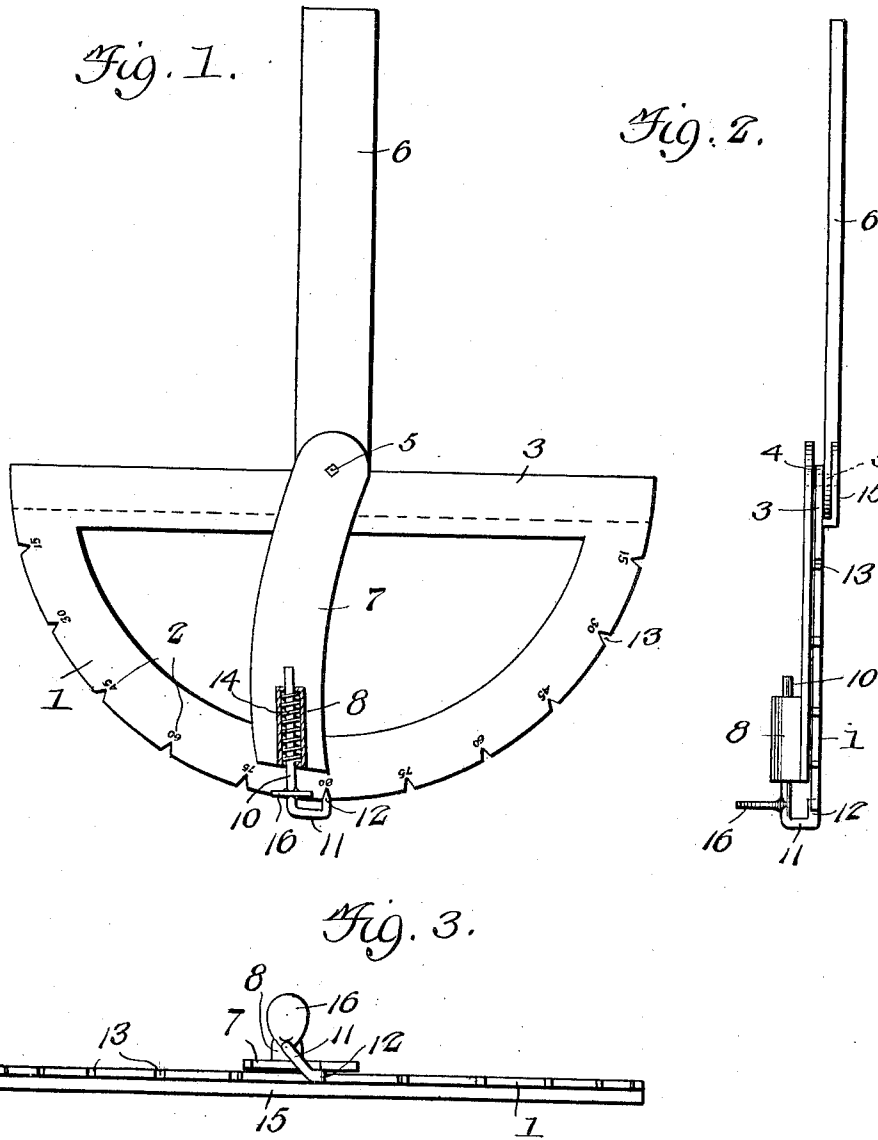

Witnesses
Hugh Holt
John J. McCarthy

Inventor
Walter P. Ward
 By *Victor J. Evans*
 Attorney

UNITED STATES PATENT OFFICE.

WALTER P. WARD, OF AUSTIN, TEXAS.

PROTRACTOR.

1,082,377.

Specification of Letters Patent.

Patented Dec. 23, 1913.

Application filed March 8, 1913. Serial No. 752,944.

To all whom it may concern:

Be it known that I, WALTER P. WARD, a citizen of the United States, residing at Austin, in the county of Travis and State of Texas, have invented new and useful Improvements in Protractors, of which the following is a specification.

This invention relates to improvements in drafting instruments and has particular application to a protractor or plotter.

In carrying out the present invention, it is my purpose to provide a protractor by means of which various angles may be laid out and wherein the blade may be swung to any desired angle relatively to the straight edge and held at such angle.

It is also my purpose to provide a device of the class described which may be readily and conveniently used and manipulated and which will embrace the desired features of simplicity, efficiency, durability and strength coupled with cheapness of cost in manufacture and marketing.

With the above and other objects in view, the invention consists in the construction, combination and arrangement of parts hereinafter set forth in and falling within the scope of the claim.

In the accompanying drawing: Figure 1 is a plan view of an instrument constructed in accordance with my present invention. Fig. 2 is a view in elevation thereof, and Fig. 3 is a similar view looking at right angles to Fig. 2.

Referring now to the accompanying drawing in detail, the numeral 1 indicates the segment of the protractor, which segment is marked off or graduated as at 2 so that various angles may be readily and accurately determined.

The numeral 3 designates a straight edge secured to the opposite extremities of the segment 1 and having fastened to the outer edge thereof in some suitable manner a block 4 in which is journaled a pivot pin 5 extending above and below the straight edge 3. Suitably fastened to one end of the pivot pin 5 and extending outwardly of the outer edge of the straight edge 3 and adapted for swinging movement relatively to such straight edge is a blade 6, while fixed to the opposite end of the pivot pin 5 is an arm 7, curved in the present instance, and disposed in a plane above the segment and straight edge and terminating adjacent to the outer

marginal edge of said segment. The free end of this arm 7 is socketed as at 8 to receive a shank 10 having the outer end thereof bent at right angles to itself as at 11 and terminating in an inwardly extending hook 12 designed to engage notches 13 formed in the marginal edge of the segment in alignment with the graduations thereon. Encircling the shank 10 within the socket 8 is a coiled expansion spring 14 exerting its tension to hold the hook 12 normally in engagement with one of the notches 13.

The numeral 15 designates an angular bracket secured to one side of the straight edge and the respective end of the pivot pin 5 and inclosing the adjacent end of the blade 6, one arm of such bracket constituting a bearing by means of which the protractor may be used in conjunction with a T-square or other analogous implement.

From the foregoing description taken in connection with the accompanying drawing, the construction and manner of using my invention will be readily apparent. By withdrawing the hook 12 on the shank 10 from engagement with the respective notch 13 in the marginal edge of the segment 1, the arm 7 and blade 6 may be swung, incident to the rigid connection formed by the pivot pin 5 between such arm and blade, to throw the blade to the desired angle relatively to the straight edge 3. When the desired angle has been obtained, the shank is released and the spring 14 reacts to engage the hook 12 with the respective notch thereby maintaining the blade at the proper angle.

In order to facilitate the release of the hook, the shank 10 is preferably provided with an upstanding thumb piece 16 whereby the shank may be readily withdrawn from the socket against the action of the spring 14 to relieve the blade 6 of the influence of the holding means, the shank and hook formed thereon and the spring 14 constituting the holding means in this form of my invention.

When it is desired to use the protractor or plotter in conjunction with a T-square or the like, the lower side of the straight edge and the contiguous portions of the segment are disposed upon the upper surface of the blade of the T-square, while the vertical member of the angular bracket 15 rests against the adjacent edge of the blade of the T-square thereby holding the protractor

true and enabling the same to be moved along the blade of the T-square in the desired manner.

5 While I have herein shown and described one preferred form of my invention by way of illustration, I desire to have it understood that I do not limit myself to the precise details of construction herein described and delineated, as modification and variation
10 may be made within the scope of the claim and without departing from the spirit of the invention.

I claim:

15 A protractor comprising a segment graduated to delineate various angles, a straight edge secured to said segment, a blade pivoted to said straight edge, an arm secured to said blade and movable therewith and overlying one face of said segment, a socket carried by

the upper surface of the free end of said 20 arm, a shank slidably disposed within said socket and having the free end thereof bent at right angles to itself and terminating in an inwardly extending hook adapted to en- 25 gage the outer edge of said segment, a spring within said socket and acting upon the shank therein to hold said hook normally in engagement with the respective edge of the segment, and means carried by said shank whereby the hook may be disengaged from 30 the respective edge of the segment against the action of said spring.

In testimony whereof I affix my signature in presence of two witnesses.

WALTER P. WARD.

Witnesses:

JAMES E. MOSBY,
CALVIN H. MADISON.

Copies of this patent may be obtained for five cents each, by addressing the "Commissioner of Patents, Washington, D. C."