

(19) World Intellectual Property
Organization
International Bureau



(43) International Publication Date
29 December 2005 (29.12.2005)

PCT

(10) International Publication Number
WO 2005/122921 A2

(51) International Patent Classification⁷: A61B 17/58

(21) International Application Number:
PCT/US2005/013721

(22) International Filing Date: 22 April 2005 (22.04.2005)

(25) Filing Language: English

(26) Publication Language: English

(30) Priority Data:
10/829,846 22 April 2004 (22.04.2004) US

(71) Applicant (for all designated States except US): SCAN-
DIUS BIOMEDICAL, INC. [US/US]; 11A Beaver Brook
Road, Littleton, MA 01460 (US).

(72) Inventors: RE, Paul; 6 Dartmouth Place, Boston, MA
02116 (US). JOHANSON, Mark, A.; 5 Harvest Lane, Lit-
tleton, MA 01460 (US). MARSHALL, Peter, F.; 6 Kettle
Hole Road, Bolton, MA 01740 (US).

(74) Agent: PANDISCIO, Mark, J.; Pandiscio & Pandiscio,
470 Totten Pond Road, Waltham, MA 02451 (US).

(81) Designated States (unless otherwise indicated, for every
kind of national protection available): AE, AG, AL, AM,
AT, AU, AZ, BA, BB, BG, BR, BW, BY, BZ, CA, CH, CN,
CO, CR, CU, CZ, DE, DK, DM, DZ, EC, EE, EG, ES, FI,
GB, GD, GE, GH, GM, HR, HU, ID, IL, IN, IS, JP, KE,
KG, KM, KP, KR, KZ, LC, LK, LR, LS, LT, LU, LV, MA,
MD, MG, MK, MN, MW, MX, MZ, NA, NI, NO, NZ, OM,
PG, PH, PL, PT, RO, RU, SC, SD, SE, SG, SK, SL, SM, SY,
TJ, TM, TN, TR, TT, TZ, UA, UG, US, UZ, VC, VN, YU,
ZA, ZM, ZW.

(84) Designated States (unless otherwise indicated, for every
kind of regional protection available): ARIPO (BW, GH,
GM, KE, LS, MW, MZ, NA, SD, SL, SZ, TZ, UG, ZM,
ZW), Eurasian (AM, AZ, BY, KG, KZ, MD, RU, TJ, TM),
European (AT, BE, BG, CH, CY, CZ, DE, DK, EE, ES, FI,
FR, GB, GR, HU, IE, IS, IT, LT, LU, MC, NL, PL, PT, RO,
SE, SI, SK, TR), OAPI (BF, BJ, CF, CG, CI, CM, GA, GN,
GQ, GW, ML, MR, NE, SN, TD, TG).

Published:
— without international search report and to be republished
upon receipt of that report

[Continued on next page]

(54) Title: APPARATUS AND METHOD FOR RECONSTRUCTING A LIGAMENT

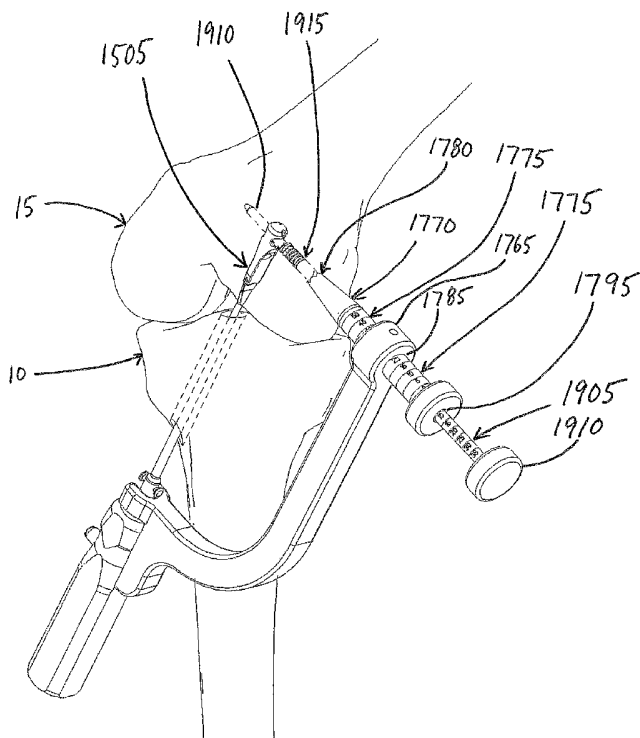

(57) Abstract: A method and apparatus for reconstruct-
ing a ligament. In one preferred form of the invention,
there is provided a graft ligament support block which
comprises a body, and a graft hole and a transverse fixa-
tion pin hole extending through the body, with both the
graft hole and the transverse fixation pin hole preferably
extending substantially perpendicular to the longitudi-
nal axis of the body. And in one preferred form of the
invention, the invention also comprises an installation
tool for inserting the graft ligament support block into
the bone tunnel and, while supporting the graft ligament
support block in the bone tunnel, forming a transverse
tunnel in the host bone, with the transverse tunnel in
the host bone being aligned with the transverse fixation
pin hole in the graft ligament support block. In one pre-
ferred method of use, a graft ligament is looped through
the graft hole in the graft ligament support block, and
the graft ligament support block is mounted to the in-
stallation tool. Then the installation tool is used to ad-
vance the graft ligament support block into the bone tun-
nel, with the two free ends of the looped graft ligament
extending back out the bone tunnel. Next, a transverse
tunnel is formed in the host bone, with the transverse
tunnel being aligned with the transverse fixation pin
hole in the graft ligament support block. Then the graft li-
gament support block is secured in place by pinning the
graft ligament support block within the tunnel, i.e., by
advancing a transverse fixation pin along the transverse

tunnel in the host bone and into the transverse fixation pin hole in the graft ligament support block. Then the installation tool is detached from the graft ligament support block, and the installation tool is withdrawn from the surgical site.

WO 2005/122921 A2



For two-letter codes and other abbreviations, refer to the "Guidance Notes on Codes and Abbreviations" appearing at the beginning of each regular issue of the PCT Gazette.

APPARATUS AND METHOD FOR
RECONSTRUCTING A LIGAMENT

Reference To Pending Prior Patent Application

5 This patent application is a continuation-in-part
of pending prior U.S. Patent Application Serial No.
10/793,532, filed 03/04/04 by Paul Re et al. for
APPARATUS AND METHOD FOR RECONSTRUCTING A LIGAMENT
(Attorney's Docket No. SCAN-2 CON), which is in turn a
10 continuation of U.S. Patent Application Serial No.
10/123,434, filed 04/16/02 by Paul Re et al. for
APPARATUS AND METHOD FOR RECONSTRUCTING A LIGAMENT
(Attorney's Docket No. SCAN-2), which in turn claims
benefit of U.S. Provisional Patent Application Serial
15 No. 60/326,351, filed 10/01/01 by Paul Re et al. for
APPARATUS AND METHOD FOR RECONSTRUCTING A LIGAMENT
(Attorney's Docket No. SCAN-2 PROV), which three patent
applications are hereby incorporated herein by
reference.

20

Field Of The Invention

This invention relates to surgical apparatus and procedures in general, and more particularly to surgical apparatus and procedures for reconstructing a ligament.

Background Of The Invention

A ligament is a piece of fibrous tissue which connects one bone to another.

Ligaments are frequently damaged (e.g., detached or torn or ruptured, etc.) as the result of injury and/or accident. A damaged ligament can cause instability, impede proper motion of a joint and cause pain.

Various procedures have been developed to repair or replace a damaged ligament. The specific procedure used depends on the particular ligament which is to be restored and on the extent of the damage.

One ligament which is frequently damaged as the result of injury and/or accident is the anterior cruciate ligament (i.e., the ACL). Looking first at Figs. 1 and 2, it will be seen that the ACL extends

between the top of the tibia 10 and the bottom of the femur 15. A damaged ACL can cause instability of the knee joint and cause substantial pain and arthritis.

Numerous procedures have been developed to restore a damaged ACL through a graft ligament replacement. In general, and looking next at Fig. 3, these ACL replacement procedures involve drilling a bone tunnel 20 up through tibia 10 and drilling a bone tunnel 25 up into femur 15. In some cases the femoral tunnel 25 may be in the form of a blind hole and terminate in a distal end surface 30; in other cases the femoral tunnel 25, or an extension of the femoral tunnel 25, may pass completely through femur 15. Once tibial tunnel 20 and femoral tunnel 25 have been formed, a graft ligament 35, consisting of a harvested or artificial ligament or tendon(s), is passed up through tibial tunnel 20, across the interior of the knee joint, and up into femoral tunnel 25. Then a distal portion of graft ligament 35 is secured in femoral tunnel 25 and a proximal portion of graft ligament 35 is secured in tibial tunnel 20.

There are currently a number of different ways to secure a graft ligament in a bone tunnel. One way is to use an interference screw 40 (Fig. 4) to wedge the graft ligament against an opposing side wall of the bone tunnel. Another way is to suspend the graft ligament in the bone tunnel with a button 45 and a suture 50 (Fig. 5) or with a crosspin 55 (Fig. 6). Still another way is to pass the graft ligament completely through the bone tunnel and affix the graft ligament to the outside of the bone with a screw 60 and washer 65 (Fig. 7) or with a staple (not shown).

The "Gold Standard" of ACL repair is generally considered to be the so-called "Bone-Tendon-Bone" fixation. In this procedure, a graft of the patella tendon is used to replace the natural ACL. Attached to the opposing ends of the harvested tendon are bone grafts, one taken from the patient's knee cap (i.e., the patella) and one taken from the patient's tibia (i.e., at the location where the patella tendon normally attaches to the tibia). The graft ligament is then deployed in the bone tunnels, with one bone graft being secured in the femoral tunnel with an

interference screw and the other bone graft being
secured in the tibial tunnel with another interference
screw. Over the years, this procedure has generally
yielded a consistent, strong and reliable ligament
5 repair. However, this procedure is also generally
considered to be highly invasive and, in many cases,
quite painful, and typically leaves unsightly scarring
on the knee and a substantial void in the knee cap.

As a result, alternative procedures have recently
10 been developed that incorporate the use of soft tissue
grafts such as the hamstring tendon. However, soft
tissue grafts such as the hamstring can be difficult to
stabilize within a bone tunnel. More particularly, the
use of an interference screw to aggressively wedge the
15 hamstring against an opposing side wall of the bone
tunnel can introduce issues such as graft slippage,
tendon winding, tissue necrosis and tendon cutting.
Furthermore, the use of a suture sling (e.g., such as
that shown in Fig. 5) and/or a crosspin (e.g., such as
20 that shown in Fig. 6) to suspend the hamstring within
the bone tunnel can introduce a different set of
issues, e.g., it has been found that the suture sling

and/or crosspin tend to permit the graft ligament to
move laterally within the bone tunnel, with a
so-called "windshield wiper" effect, thereby impeding
ingrowth between the graft ligament and the host bone
and/or causing abrasion and/or other damage to the
5 graft tissue. In addition, the use of a crosspin
(e.g., such as that shown in Fig. 6) to secure a
hamstring within the bone tunnel can introduce still
other issues, e.g., difficulties in looping the
10 hamstring over the crosspin, or tearing of the
hamstring along its length during tensioning if and
where the crosspin passes through the body of the
hamstring, etc.

15 Summary Of The Invention

As a result, one object of the present invention
is to provide improved apparatus for reconstructing a
ligament, wherein the apparatus is adapted to permit
the graft ligament to be fashioned out of various soft
20 tissue grafts, e.g., allografts, autografts,
xenografts, bioengineered tissue grafts or synthetic

grafts, and further wherein the graft is intended to be secured in place using a transverse fixation pin.

Another object of the present invention is to provide an improved method for reconstructing a
5 ligament, wherein the method is adapted to permit the graft ligament to be fashioned out of various soft tissue grafts, e.g., allografts, autografts, xenografts, bioengineered tissue grafts or synthetic grafts, and further wherein the graft is intended to be
10 secured in place using a transverse fixation pin.

These and other objects are addressed by the present invention which comprises, in one preferred form of the invention, the provision and use of a graft ligament support block which comprises a body, and a
15 graft hole and a transverse fixation pin hole extending through the body, with both the graft hole and the transverse fixation pin hole preferably extending substantially perpendicular to the longitudinal axis of the body. In one preferred form of the invention, the
20 invention also comprises an installation tool for inserting the graft ligament support block into the bone tunnel and, while supporting the graft ligament

support block in the bone tunnel, forming a transverse tunnel in the host bone, with the transverse tunnel in the host bone being aligned with the transverse fixation pin hole in the graft ligament support block.

5 In one preferred method of use, a graft ligament is looped through the graft hole in the graft ligament support block, and the graft ligament support block is mounted to the installation tool. The two free ends of the graft ligament are then preferably secured to a
10 proximal portion of the installation tool under tension, whereby to tie down the two free ends of the graft ligament. In addition to controlling the two free ends of the graft ligament, this arrangement will also help hold the graft ligament support block to the
15 installation tool. Then the installation tool is used to advance the graft ligament support block through the tibial tunnel, across the interior of the knee joint, and up into the femoral tunnel, with the two free ends of the looped graft ligament extending back out through
20 the tibial tunnel. Next, a transverse tunnel is formed in the host bone, with the transverse tunnel being aligned with the transverse fixation pin hole in the

graft ligament support block. Then the graft ligament support block is secured in place by pinning the graft ligament support block within the femoral tunnel, i.e., by advancing a transverse fixation pin along the transverse tunnel in the host bone and into the transverse fixation pin hole in the graft ligament support block. Then the two free ends of the looped graft ligament are released from the installation tool, the installation tool is detached from the graft ligament support block, and the installation tool is withdrawn from the surgical site. Finally, the two free ends of the looped graft ligament are secured to the tibia, thus completing the ACL repair. If desired, the tibial attachment can be effected using a second graft ligament support block.

In accordance with a further feature of the invention, there is provided apparatus for use in reconstructing a ligament, the apparatus comprising:

a graft ligament support block for supporting a graft ligament in a bone tunnel, the graft ligament support block comprising:

a body having a distal end, a proximal end,
and a longitudinal axis extending between the distal
end and the proximal end, the proximal end being
tapered so as to facilitate withdrawal of the graft
5 ligament support block through a bone tunnel;

a graft hole extending through the body
transverse to the longitudinal axis and configured to
receive a graft ligament therein; and

10 a transverse fixation pin hole extending
through the body transverse to the longitudinal axis
and configured to receive a transverse fixation pin
therein.

In accordance with a still further feature of the
invention, there is provided a method for securing a
15 graft ligament in a bone tunnel, comprising the steps
of:

(1) looping a graft ligament through a graft hole
in a graft ligament support block, advancing the graft
ligament support block into the bone tunnel,
20 withdrawing the graft ligament support block back down
the bone tunnel, advancing a graft ligament support
block into the bone tunnel, with a graft ligament being

looped through a graft hole in the graft ligament support block, and forming a transverse tunnel in the host bone, with a transverse fixation pin hole in the graft ligament support block being aligned with the transverse tunnel in the host bone; and

(2) pinning the graft ligament support block within the bone tunnel by advancing a transverse fixation pin along the transverse tunnel in the host bone and into the transverse fixation pin hole in the graft ligament support block.

In accordance with a further feature of the invention, there is provided a method for revising a graft ligament in a bone tunnel, the method comprising the steps of:

unpinning a graft ligament support block within a bone tunnel by withdrawing a transverse fixation pin from a transverse fixation pin hole in the graft ligament support block and from a transverse tunnel a host bone;

withdrawing the graft ligament support block back down the bone tunnel;

advancing a graft ligament support block into the bone tunnel so that a transverse fixation pin hole in the support block is aligned with the transverse tunnel; and

5 pinning the graft ligament support block within the bone tunnel by advancing the transverse fixation pin along the transverse tunnel in the host bone and into the transverse fixation pin hole in the graft ligament support block.

10 In accordance with a further feature of the invention, there is provided apparatus for use in reconstructing a ligament, the apparatus comprising:

.5 a graft ligament support block for supporting a graft ligament in a bone tunnel, the graft ligament support block comprising:

a body having a distal end, a proximal end, and a longitudinal axis extending between the distal end and the proximal end;

!0 a graft hole extending through the body transverse to the longitudinal axis and configured to receive a graft ligament therein, the graft hole having

a given length along the longitudinal axis, the given length being substantially equal to a given cross-sectional dimension of the graft ligament; and
a transverse fixation pin hole extending
5 through the body transverse to the longitudinal axis and configured to receive a transverse fixation pin therein.

In accordance with a still further feature of the invention, there is provided a method for securing a
10 graft ligament in a bone tunnel, comprising the steps of:

selecting a graft ligament support block with a graft hole sized substantially equal to a given cross-sectional dimension of a graft ligament;

15 looping the graft ligament through the graft hole in a graft ligament support block;

advancing the graft ligament support block into the bone tunnel;

forming a transverse tunnel in the host bone, with
20 a transverse tunnel being aligned with a transverse fixation pin hole in the graft ligament support block;
and

pinning the graft ligament support block within
the bone tunnel by advancing a transverse fixation pin
along the transverse tunnel in the host bone and into
the transverse fixation pin hole in the graft ligament
support block.

In accordance with another feature of the
invention, there is provided a method for securing a
graft ligament in a bone tunnel, the method comprising
the steps of:

- forming a transverse tunnel in the host bone;
- selecting a graft ligament support block with a
graft hole sized substantially equal to a given
cross-sectional dimension of a graft ligament;
- looping the graft ligament through the graft hole
in the graft ligament support block;
- advancing the graft ligament support block into
the bone tunnel so that a transverse fixation pin hole
in the graft ligament support block is aligned with the
transverse tunnel; and
- pinning the graft ligament support block within
the bone tunnel by advancing a transverse fixation pin
along the transverse tunnel in the host bone and into

the transverse fixation pin hole in the graft ligament support block.

In accordance with a further feature of the invention, there is provided apparatus for use in reconstructing a ligament, the apparatus comprising:

a graft ligament support block for supporting a graft ligament in a bone tunnel, the graft ligament support block comprising:

a body having a distal end, a proximal end, and a longitudinal axis extending between the distal end and the proximal end;

a graft hole extending through the body transverse to the longitudinal axis and configured to receive a graft ligament therein; and

a transverse fixation pin hole extending through the body transverse to the longitudinal axis and configured to receive a transverse fixation pin therein; and

a transverse fixation pin having a proximal end and a distal end, and the proximal end forming an internal tapped hole therein so as to aid removal of the transverse fixation pin from the bone tunnel.

In accordance with a still further feature of the invention, there is provided a method for revising a graft ligament in a bone tunnel, comprising the steps of:

5 engaging an internal tapped hole in a transverse fixation pin with a removal tool;

 withdrawing the transverse fixation pin from the bone tunnel with removal tool engaged with the internal tapped hole, and withdrawing a graft ligament support
10 block back down the bone tunnel;

 positioning a graft ligament support block into the bone tunnel;

 pinning the graft ligament support block within the bone tunnel by advancing a transverse fixation pin
15 along a transverse tunnel in the host bone and into the transverse fixation pin hole in the graft ligament support block.

 In accordance with a further feature of the invention, there is provided a system for use in
20 reconstructing a ligament, the system comprising:

a graft ligament support block for supporting a graft ligament in a bone tunnel, the graft ligament support block comprising:

5 a body having a distal end, a proximal end, and a longitudinal axis extending between the distal end and the proximal end;

a graft hole extending through the body transverse to the longitudinal axis and configured to receive a graft ligament therein;

10 a stepped fixation pin having a distal end, a proximal end, a longitudinal axis extending between the distal end and the proximal end, a first portion at the distal end, a second portion at the proximal end, the first portion having a smaller diameter than second portion, and an annular shoulder configured between the first portion and the second portion, wherein the first portion, the second portion and the annular shoulder form a given profile in a cross-section of a given plane perpendicular to the longitudinal axis; and

15 20 a stepped transverse tunnel drill having a distal end, a proximal end, and a longitudinal axis extending between the distal end and the proximal end, the

stepped transverse drill corresponding to the given profile of the stepped fixation pin so as to provide a stepped transverse tunnel through a portion of the bone tunnel configured to align with a pathway of the transverse fixation pin hole, wherein the transverse fixation pin hole extends through the body transverse to the longitudinal axis and is configured to receive a transverse fixation pin therein.

In accordance with a further feature of the invention, there is provided a method for securing a graft ligament in a bone tunnel, comprising the steps of:

looping a graft ligament through a graft hole in a graft ligament support block;

advancing the graft ligament support block into the bone tunnel;

forming a stepped transverse tunnel in the host bone with a stepped transverse tunnel drill, with the stepped transverse tunnel being aligned with a transverse fixation pin hole in the graft ligament support block; and

- 19 -

pinning the graft ligament support block within
the bone tunnel by advancing a stepped transverse
fixation pin along the transverse tunnel in the host
bone and into the transverse fixation pin hole in the
5 graft ligament support block.

In accordance with a still further feature of the
invention, there is provided a method for securing a
graft ligament in a bone tunnel, the method comprising
the steps of:

10 forming a stepped transverse tunnel in the host
bone with a stepped transverse tunnel drill;

looping a graft ligament through a graft hole in a
graft ligament support block;

15 advancing the graft ligament support block into
the bone tunnel so that a transverse fixation pin hole
in the graft ligament support block is aligned with the
stepped transverse tunnel; and

20 pinning the graft ligament support block within
the bone tunnel by advancing a stepped transverse
fixation pin along the stepped transverse tunnel in the
host bone and into the transverse fixation pin hole in
the graft ligament support block.

- 20 -

In accordance with a further feature of the invention, there is provided a system for use in reconstructing a ligament, the system comprising:

a graft ligament support block for supporting a graft ligament in a bone tunnel, the graft ligament support block comprising:

a body having a distal end, a proximal end, a longitudinal axis extending between the distal end and the proximal end, and at least one element for engagement by an installation tool;

a graft hole extending through the body transverse to the longitudinal axis and configured to receive a graft ligament therein; and

a transverse fixation pin hole extending through the body transverse to the longitudinal axis and configured to receive a transverse fixation pin therein;

an installation tool comprising:

a holder, the holder comprising:

a shaft having a distal end, a proximal end, and a longitudinal axis extending between the distal end and the proximal end, the proximal end of

- 21 -

the shaft configured to engage the at least one element of the body;

a handle mounted to the proximal end of the shaft;

5 a drill guide adapted to be releasably secured to the holder, the drill guide comprising:

an outrigger comprising a distal end and a proximal end, the proximal end of the outrigger configured to be releasably secured to the holder; and

10 a drill sleeve moveably attached to the distal end of the outrigger, the drill sleeve comprising a drilling lumen extending therethrough, and the drill sleeve having depth markers thereon, wherein the distal end of the outrigger and the depth markers on the drill sleeve are configured so as to indicate a proper transverse tunnel depth; and

15 a transverse tunnel drill having a distal end and a proximal end, the distal end of the transverse tunnel drill configured for placement through the drill sleeve so as to drill a transverse bone tunnel through the bone tunnel, the transverse tunnel drill having markers disposed thereon between the proximal end and the

20

- 22 -

distal end thereof, wherein the depth markers on the transverse tunnel drill and the drill sleeve are configured so as to indicate a given depth of the distal end of the transverse tunnel drill.

5 In accordance with a further feature of the invention, there is provided a method for securing a graft ligament in a bone tunnel, comprising the steps of:

10 looping a graft ligament through a graft hole in a graft ligament support block;

 advancing the graft ligament support block into the bone tunnel;

15 positioning a drill guide in attachment to the graft support block, the drill guide comprising an outrigger and a drill sleeve movably attached to the outrigger, and the drill sleeve having depth markers thereon;

20 determining a proper transverse tunnel depth with the drill sleeve and the outrigger by moving the drill sleeve within the outrigger toward the bone tunnel and reading the depth markers on the drill sleeve;

forming a transverse tunnel in the host bone to a proper transverse tunnel depth by drilling a transverse tunnel drill to a given depth according to markers disposed on thereon, with the transverse tunnel being aligned with a transverse fixation pin hole in the graft ligament support block; and

pinning the graft ligament support block within the bone tunnel by advancing a transverse fixation pin along the transverse tunnel in the host bone and into the transverse fixation pin hole in the graft ligament support block.

In accordance with a still further feature of the invention, there is provided a method for securing a graft ligament in a bone tunnel, the method comprising the steps of:

positioning a drill guide in attachment to a reamer inserted into the bone tunnel, the drill guide comprising an outrigger and a drill sleeve movably attached to the outrigger, and the drill sleeve having depth markers thereon;

determining a proper transverse tunnel depth with the drill sleeve and the outrigger by moving the drill

sleeve within the outrigger toward the bone tunnel and reading the depth markers on the drill sleeve;

forming a transverse tunnel in the host bone to a proper transverse tunnel depth by drilling a transverse tunnel drill to a given depth according to markers
5 disposed thereon;

removing the reamer from the bone tunnel;

looping a graft ligament through a graft hole in a graft ligament support block;

10 advancing the graft ligament support block into the bone tunnel so that a transverse fixation pin hole in the graft ligament support block is aligned with the transverse tunnel; and

15 pinning the graft ligament support block within the bone tunnel by advancing a transverse fixation pin along the transverse tunnel in the host bone and into the transverse fixation pin hole in the graft ligament support block.

20 In accordance with a further feature of the invention, there is provided a system for use in reconstructing a ligament, the system comprising:

- 25 -

a graft ligament support block for supporting a graft ligament in a bone tunnel, the graft ligament support block comprising:

5 a body having a distal end, a proximal end, a longitudinal axis extending between the distal end and the proximal end, and at least one element for engagement by an installation tool;

10 a graft hole extending through the body transverse to the longitudinal axis and configured to receive a graft ligament therein; and

a transverse fixation pin hole extending through the body transverse to the longitudinal axis and configured to receive a transverse fixation pin therein;

15 an installation tool comprising:

a holder, the holder comprising:

20 a shaft having a distal end, a proximal end, and longitudinal axis extending between the distal end and the proximal end, the proximal end of the shaft configured to engage the at least one element of the body;

- 26 -

a handle mounted to the proximal end of the shaft;

a drill guide adapted to be releasably secured to the holder, the drill guide comprising:

5 an outrigger comprising a distal end and a proximal end, the proximal end of the outrigger configured to be releasably secured to the holder; and

a drill sleeve moveably attached to the distal end of the outrigger, and the drill sleeve comprising a drilling lumen extending therethrough; and

10 a transverse tunnel drill having a distal end and a proximal end, the distal end of the transverse tunnel drill configured for placement through the drill sleeve so as to drill a transverse bone tunnel through the bone tunnel, the transverse tunnel drill having a stop element configured to engage the drill sleeve so as to limit drilling to a predetermined depth.

15 In accordance with a further feature of the invention, there is provided a system for use in reconstructing a ligament, the system comprising:

20

- 27 -

a graft ligament support block for supporting a graft ligament in a bone tunnel, the graft ligament support block comprising:

5 a body having a distal end, a proximal end, and a longitudinal axis extending between the distal end and the proximal end; and

a graft hole extending through the body transverse to the longitudinal axis and configured to receive a graft ligament therein;

10 a stepped transverse fixation pin having a distal end, a proximal end, a longitudinal axis extending between the distal end and the proximal end, a first portion at the distal end, a second portion at the proximal end, the first portion having a smaller
15 diameter than second portion, and an annular shoulder configured between the first portion and the second portion, wherein the first portion, the second portion and the annular shoulder form a given profile in a cross-section of a given plane perpendicular to the
20 longitudinal axis;

a stepped transverse tunnel drill having a distal end, a proximal end and a longitudinal axis extending

- 28 -

between the distal end and the proximal end, the stepped transverse drill corresponding to the given profile of the stepped transverse fixation pin so as to provide a stepped transverse tunnel through the bone tunnel configured to receive the given profile of the stepped transverse fixation pin; and

a depth gauge having a distal end and a proximal end, the distal end of the depth gauge configured for placement through a drill sleeve to engage a portion of the stepped transverse tunnel corresponding to the annular shoulder of the stepped fixation pin, and the depth gauge having markings thereon between the distal end and the proximal end so as to indicate the transverse fixation pin hole depth between the portion corresponding to the annular shoulder of the stepped fixation pin and a bone surface.

In accordance with a still further feature of the invention, there is provided a method for securing a graft ligament in a bone tunnel, comprising the steps of:

looping a graft ligament through a graft hole in a graft ligament support block;

advancing the graft ligament support block into the bone tunnel;

determining a proper transverse tunnel depth by reading a position of a first set of depth markers on a drill sleeve relative to an outrigger;

forming a transverse tunnel in the host bone using a transverse tunnel drill having a second set of depth markers thereon so as to drill the transverse tunnel to the proper transverse tunnel depth, with a transverse tunnel being aligned with a transverse fixation pin hole in the graft ligament support block; and

pinning the graft ligament support block within the bone tunnel by selecting a transverse fixation pin based on the proper transverse tunnel depth determined by the first set of depth markers on the drill sleeve and advancing the selected transverse fixation pin along the transverse tunnel in the host bone and into the transverse fixation pin hole in the graft ligament support block.

In accordance with a further feature of the invention, there is provided a method for securing a

- 30 -

graft ligament in a bone tunnel, comprising the steps
of:

looping a graft ligament through a graft hole in a
graft ligament support block;

5 advancing the graft ligament support block into
the bone tunnel;

determining a proper transverse tunnel depth by
reading a position of a first set of depth markers on a
drill sleeve relative to an outrigger;

10 forming a transverse tunnel in the host bone using
a transverse tunnel drill having a second set of depth
markers thereon so as to drill the transverse tunnel to
the proper transverse tunnel depth, with the transverse
tunnel being aligned with a transverse fixation pin
15 hole in the graft ligament support block; and

pinning the graft ligament support block within
the bone tunnel by selecting a transverse fixation pin
based on the proper transverse tunnel depth determined
by the first set of depth markers on the drill sleeve
20 and advancing the selected transverse fixation pin
along the transverse tunnel in the host bone and into

- 31 -

the transverse fixation pin hole in the graft ligament support block.

In accordance with a further feature of the invention, there is provided a method for securing a graft ligament in a bone tunnel, comprising the steps
5 of:

looping a graft ligament through a graft hole in a graft ligament support block;

10 advancing the graft ligament support block into the bone tunnel;

forming a transverse tunnel in the host bone to a predetermined depth using a transverse tunnel drill having a stop element at a predetermined distance from a distal end of the transverse tunnel drill, the stop
15 element configured to engage a drill sleeve so as to limit drilling to the predetermined depth, with said transverse tunnel being aligned with a transverse fixation pin hole in the graft ligament support block;
and

20 pinning the graft ligament support block within the bone tunnel by advancing a transverse fixation pin along the transverse tunnel in the host bone and into

- 32 -

the transverse fixation pin hole in the graft ligament support block.

In accordance with a still further feature of the invention, there is provided a method for securing a graft ligament in a bone tunnel, the method comprising the steps of:

forming a transverse tunnel in the host bone to a predetermined depth using a transverse tunnel drill having a stop element at a predetermined distance from a distal end of the transverse tunnel drill, the stop element configured to engage a drill sleeve so as to limit drilling to the predetermined depth;

looping a graft ligament through a graft hole in a graft ligament support block;

advancing the graft ligament support block into the bone tunnel so that a transverse fixation pin hole in the graft ligament support block is aligned with the transverse tunnel; and

pinning the graft ligament support block within the bone tunnel by advancing a transverse fixation pin along the transverse tunnel in the host bone and into

the transverse fixation pin hole in the graft ligament support block.

In accordance with a further feature of the invention, there is provided apparatus for use in reconstructing a ligament, the apparatus comprising:

a graft ligament support block for supporting a graft ligament in a bone tunnel, the graft ligament support block comprising:

a body having a distal end, a proximal end, and a longitudinal axis extending between the distal end and the proximal end, the proximal end being tapered so as to facilitate withdrawal of the graft ligament support block through the bone tunnel;

a graft hole extending through the body transverse to the longitudinal axis and configured to receive a graft ligament therein; and

a region configured for drilling a transverse fixation pin hole through the body transverse to the longitudinal axis as a transverse hole is drilled through the bone tunnel.

Brief Description Of the Drawings

These and other objects and features of the present invention will be more fully disclosed or rendered obvious by the following detailed description of the preferred embodiments of the invention, which is
5 to be considered together with the accompanying drawings wherein like numbers refer to like parts and further wherein:

Fig. 1 is a schematic view of a knee joint, as
10 viewed from the anterior side;

Fig. 2 is a schematic view of a knee joint, as viewed from the posterior side;

Fig. 3 is a schematic view of a generic ACL reconstruction;

15 Fig. 4 is a schematic view of an ACL reconstruction effected using an interference screw;

Fig. 5 is a schematic view of an ACL reconstruction effected using a suture sling;

20 Fig. 6 is a schematic view of an ACL reconstruction effected using a crosspin;

Fig. 7 is a schematic view of an ACL reconstruction effected using a screw and washer;

Fig. 8 is a schematic view of a graft ligament support block formed in accordance with the present invention;

5 Fig. 9 is a partially exploded view showing the graft ligament support block of Fig. 8 and an installation tool for deploying the same;

Figs. 10-12 are various views showing the graft ligament support block of Fig. 8 mounted to the distal end of the installation tool shown in Fig. 9;

10 Fig. 13 is a partial perspective view showing details of the proximal end of the installation tool shown in Fig. 9;

15 Fig. 14 is a side view, partially in section, showing further details of the construction of the installation tool shown in Fig. 9;

Fig. 15 is a side sectional view of the installation tool's drill sleeve;

20 Fig. 16 is a perspective view of a transverse fixation pin which may be used in conjunction with the graft ligament support block of Fig. 8 and the installation tool of Fig. 9;

Figs. 17-33 are a series of schematic views showing an ACL reconstruction being effected in accordance with the present invention;

5 Fig. 34 is a schematic view showing another form of graft ligament support block formed in accordance with the present invention;

Fig. 35 is an enlarged side view showing an alternative construction for a portion of the installation tool;

10 Fig. 36 is a sectional view taken along line 36-36 of Fig. 35;

Fig. 37 is a schematic view showing a reamer drill guide formed in accordance with the present invention;

15 Fig. 38 is a schematic view showing the reamer element of the reamer drill guide shown in Fig. 37;

Figs. 39-44 are a series of schematic views showing an ACL reconstruction being effected in accordance with the present invention;

20 Figs. 45, 46A and 46B are schematic views of graft ligament support blocks, with each one showing a tapered distal edge configuration;

Fig. 47 is a schematic view of a transverse fixation pin having an internal tapped hole formed at its proximal end;

5 Fig. 48 is a schematic view of a retraction tool having a threaded projection configured to engage the internal tapped hole of the transverse fixation pin shown in Fig. 47;

10 Fig. 49 is a schematic view showing a stepped transverse tunnel drill having a narrow cutting portion and a wide cutting portion;

Fig. 50 is a schematic view of an ACL reconstruction procedure effected using the stepped transverse tunnel drill shown in Fig. 49;

15 Figs. 51A, 51B and 52 are schematic views of a system for use in reconstructing a ligament, the system including a stepped transverse tunnel drill with depth markers thereon and a drill sleeve with depth markers thereon;

20 Figs. 53 and 54 are schematic views of a transverse tunnel drill having a stop element configured thereon; and

Figs. 55 and 56 are schematic views of a system for use in reconstructing a ligament, the system including a transverse pin inserter depth gauge configured to determine the placement depth of a transverse pin inserted into the transverse tunnel.

Detailed Description Of the Preferred Embodiment

Looking next at Fig. 8, there is shown a graft ligament support block 100 which comprises one preferred form of the invention. Graft ligament support block 100 comprises a body 105, and a graft hole 110 and a transverse fixation pin hole 115 extending through body 105, with both graft hole 110 and transverse fixation pin hole 115 preferably extending substantially perpendicular to the longitudinal axis 120 of body 105. In one preferred form of the invention, graft hole 110 and transverse fixation pin hole 115 extend diametrically across body 105, with graft hole 110 and transverse fixation pin hole 115 extending substantially parallel to one another. Preferably graft hole 110 resides closer to the proximal end 125 of body 105 than transverse

fixation pin hole 115, and transverse fixation pin hole 115 resides closer to the distal end 130 of body 105 than graft hole 110. In one preferred form of the invention, the distal end of body 105 has a circular cross-section, although it may also have an oval cross-section or a polygonal cross-section (e.g., square or rectangular or triangular, etc.). In one preferred construction, the distal end of body 105 has a cross-section sized just slightly smaller than the diameter of the bone tunnel, so as to provide a close interface between body 105 and the walls of the bone tunnel. In one preferred form of the invention, the distal end 130 of body 105 is tapered so as to facilitate advancement of graft ligament support block 100 through a bone tunnel. And in a preferred form of the invention, the proximal end of body 105 is sculpted away, e.g. such as shown at 135, so as to provide more room for a graft ligament looped through graft hole 110 and extending distally therefrom. Body 105 also includes a pair of recesses 140 for mounting body 105 to an appropriate installation tool, as will hereinafter be discussed in further detail.

If desired, graft ligament support block 100 may also include suture hole 145 for receiving a tow suture, as will hereinafter be discussed in further detail.

5 Additionally, if desired, the proximal end of graft hole 110 may be tapered as shown at 150 so as to provide a less traumatic bearing surface for a graft ligament looped through graft hole 110, and/or the entrance of transverse fixation pin hole 115 may be
10 tapered as shown at 155 so as to facilitate entry of a transverse fixation pin into transverse fixation pin hole 115.

 Body 105 may be formed out of a polymer, a bioabsorbable or bioremodelable material, allograft
15 bone, a metal, a ceramic, coral, a fiber composite, a composite including at least one of the foregoing, etc. By forming body 105 out of a relatively strong material, the graft ligament can be held under tension even where body 105 is relatively small, or where one
20 or more of the holes 110, 115 and/or 145 is located fairly close to the periphery of body 105.

Looking next at Figs. 9-15, there is shown an installation tool 200 which may be used in conjunction with graft ligament support block 100. Installation tool 200 generally comprises a holder 205 and an associated drill guide 210.

Holder 205 comprises a shaft 215 having a pair of fingers 220 at its distal end and a handle 225 at its proximal end. Fingers 220 allow installation tool 200 to mate with, and releasably hold, graft ligament support block 100 by selectively fitting into the recesses 140 (Fig. 8) formed on the proximal end of graft ligament support block 100. See Figs. 9-12 and 14. In essence, fingers 220 and recesses 140 comprise a male/female connection; if desired, the locations of the male and female members may be reversed (i.e., with the male portion on support block 100 and the female portion on holder 205); or an alternative type of connection (e.g., a grasper) may be used. Preferably one or more suture posts 227 are formed on the proximal end of shaft 215 adjacent to handle 225. Suture posts 227 allow the two free ends of a graft ligament to be secured to the installation tool, as will hereinafter

be discussed in further detail. Handle 225 allows installation tool 200 to be conveniently grasped by a user. Handle 225 includes a post hole 230. Post hole 230 allows drill guide 210 to be releasably secured to holder 205, as will hereinafter be discussed in further detail.

Drill guide 210 comprises an outrigger 235 having a threaded bore 240 (Fig. 14) formed in its distal end 245, and a slot 250 (Fig. 9) and post 255 at its proximal end 260. The end of post 255 is threaded, e.g., as shown at 265.

The threaded bore 240 (Fig. 14) in the outrigger's distal end 245 is sized to receive a drill sleeve 270 therein. Drill sleeve 270 has threads 275 along its length and terminates in a proximal head 280. Head 280 can be used to manually rotate drill sleeve 270 within the outrigger's threaded bore 240, whereby to move drill sleeve 270 relative to the distal end 245 of outrigger 235. A lumen 285 extends through drill sleeve 270.

Slot 250 and post 255 permit outrigger 235 to be releasably mounted to holder 205. More particularly,

outrigger 235 may be mounted to holder 205 by fitting the holder's shaft 215 in the outrigger's slot 250 (Figs. 13 and 14), fitting the outrigger's post 255 in the holder's post hole 230, and then tightening nut 290 onto the threaded end 265 of post 255.

As will hereinafter be described, graft ligament support block 100 and installation tool 200 are intended to be used in conjunction with a transverse fixation pin. One preferred transverse fixation pin 300 is shown in Fig. 16. Transverse fixation pin 300 generally comprises a solid shaft 305 terminating in a tapered distal end 310, and a ribbed (or barbed or threaded) section 315. A non-circular socket 320 is formed in the proximal end of transverse fixation pin 300, whereby transverse fixation pin 300 may be engaged by a driver.

An ACL reconstruction effected in accordance with the present invention will now be described.

First, the surgical site is prepared for the graft ligament, e.g., by clearing away the damaged ACL, etc. Then a guidewire 400 (Fig. 17) is drilled up through tibia 10 and into the interior of the knee joint.

Preferably guidewire 400 is stopped short of engaging the bottom of femur 15 (Fig. 18). Then a cannulated tibial drill 500 (Fig. 19) is loaded onto guidewire 400 and drilled up through tibia 10 and into the interior of the knee joint (Fig. 20). Then cannulated tibial drill 500 is withdrawn back down the guidewire (Fig. 21), leaving a tibial tunnel 20.

Next, guidewire 400 is drilled an appropriate distance into the interior of femur 15. If desired, guidewire 400 may be drilled all the way through femur 15 (Fig. 22), for reasons which will hereinafter be described. Then a cannulated femoral drill 600 (e.g., an acorn drill) is loaded onto guidewire 400 (Fig. 22), passed through tibial tunnel 20, across the interior of the knee joint, and then drilled up into femur 15, stopping within the interior of femur 15 (Fig. 23). Then cannulated femoral drill 600 is withdrawn back down the guidewire, leaving a femoral tunnel 25 (Fig. 24).

Next, a graft ligament 35 is mounted to graft ligament support block 100 by threading one end of the graft ligament through graft hole 110, and then graft

ligament support block 100 is mounted to the distal end of shaft 215, i.e., by seating fingers 220 in recesses 140. The two free ends of graft ligament 35 are preferably held taut, e.g., by passing sutures 70 through the two free ends of graft ligament 35 and then securing those sutures (e.g., by winding) to suture posts 227. This arrangement will help control the two free ends of graft ligament 35 and will help hold graft ligament support block 100 to holder 205. Then installation tool 200 is used to push graft ligament support block 100, and hence graft ligament 35, up through tibial tunnel 20 (Fig. 25), across the interior of the knee joint, and up into femoral tunnel 25 (Fig. 26).

If desired, all of the force required to advance graft ligament support block 100 and graft ligament 35 through tibial tunnel 20, across the interior of the knee joint, and up into femoral tunnel 25 may be supplied by pushing distally on installation tool 200. Alternatively, if guidewire 400 has been drilled completely through femur 15 (e.g., such as is shown in Fig. 22), and if the proximal end of guidewire 400

includes a suture eyelet (e.g., such as the suture eyelet 405 shown in Figs. 23 and 24), a suture may be used to help tow graft ligament support block 100 and graft ligament 35 up into position. More particularly, a suture 700 (Fig. 25) may be looped through the suture hole 145 in graft ligament support block 100 and through suture eyelet 405 on guidewire 400; then, by pulling distally on the portion of guidewire 400 extending out of the top end of femur 15, suture 700 can be used to help tow graft ligament support block 100 and graft ligament 35 up into position (Fig. 26). Such an arrangement will help reduce the amount of force which needs to be delivered by installation tool 200 to push graft ligament support block 100 and graft ligament 35 up into position.

Once graft ligament support block 100 and graft ligament 35 have been advanced into position (Fig. 26), drill sleeve 270 is advanced into tight engagement with femur 15 (Fig. 27). This action will help stabilize installation tool 200 relative to femur 15. Then a transverse tunnel drill 800 (Fig. 28) is used to drill a transverse tunnel 75 through the lateral portion of

femur 15, through transverse fixation pin hole 115 in graft ligament support block 100, and into the medial portion of femur 15. In this respect it will be appreciated that transverse tunnel drill 800 will be accurately and consistently directed through transverse fixation pin hole 115 in graft ligament support block 100 (Fig. 28) due to the fact that the orientation of graft ligament support block 100 and installation tool 200 (and hence drill sleeve 270) is regulated by the engagement of fingers 220 in recesses 140.

Once transverse tunnel drill 800 has been used to drill transverse tunnel 75, transverse tunnel drill 800 is removed (Fig. 29). Then drill sleeve 270 is loosened and outrigger 210 dismounted from holder 205 (Fig. 30). Then transverse fixation pin 300, mounted on a driver 325, is advanced into transverse tunnel 75 and across transverse fixation pin hole 115 in graft ligament support block 100 (Fig. 31), whereby to secure graft ligament support block 100 (and hence graft ligament 35) in femoral tunnel 25. Depending on whether section 315 of transverse fixation pin 300 is ribbed or barbed or threaded, the transverse fixation

pin may be advanced by driver 325 by tapping on the proximal end of the driver with a mallet or by rotating the driver and/or both. The driver 325 is then removed (Fig. 32). Next, the two free ends of graft ligament 35 are detached from the handle's suture posts 227, and holder 205 is withdrawn (Fig. 33). In this respect it will be appreciated that graft ligament support block 100 will be held in position in femoral tunnel 25 when holder 205 is withdrawn due to the presence of transverse fixation pin 300 in transverse tunnel 75 and transverse fixation pin hole 115. Finally, the two free ends of graft ligament 35 are secured to tibia 10, thereby completing the ACL reconstruction procedure.

In the embodiment disclosed above, transverse fixation pin hole 115 (Fig. 8) is pre-formed in body 105. Such a construction is generally advantageous, since it eliminates the need to drill through body 105 after graft ligament support block 100 has been positioned in the femoral tunnel and before transverse fixation pin 300 has been passed through body 105. In addition, by pre-forming transverse fixation pin hole 115 in body 105, transverse fixation pin hole 115 can

be given a desired geometry, e.g., it permits the entrance to crosspin hole 115 to be tapered, such as is shown at 155 in Fig. 8, whereby to help center transverse fixation pin 300 in transverse fixation pin hole 115. However, it should also be appreciated that, if desired, transverse fixation pin hole 115 may not be pre-formed in body 105. Instead, transverse fixation pin hole 115 may be formed in situ, at the time of surgery, e.g., by drilling across body 105 when forming transverse tunnel 75 with transverse tunnel drill 800. Where transverse fixation pin hole 115 is to be formed in situ, it is of course necessary for body 105 to be formed out of a drillable material. In addition, where transverse fixation pin hole 115 is to be formed in situ, it is preferred that body 105 be formed out of a relatively strong material, since then any misplacement (i.e., any off-center placement) of transverse fixation pin hole 115 will be well tolerated by body 105.

Additionally, in the embodiment disclosed above, the outer surface of body 105 is sculpted away proximal to graft hole 110, such as is shown at 135 in Fig. 8, so as to help accommodate the graft ligament in femoral

tunnel 25. In Fig. 8, sculpting is effected so as to produce a substantially planar surface at 135.

However, if desired, sculpting can be effected so as to provide alternative geometries, e.g., a surface groove,

5 etc. Thus, for example, in Fig. 34 body 105 is shown with a pair of surface grooves 165 communicating with, and extending proximally from, graft hole 110. Surface grooves 165 are sized so as to provide a recess for seating portions of the graft ligament as the graft
10 ligament extends proximally from graft hole 110.

Also, in the embodiment disclosed above, body 105 is shown (see, for example, Fig. 8) as having a relatively smooth outer surface. However, if desired, body 105 may have spikes or ribs, etc. formed on a side
15 wall thereof so as to help stabilize body 105 within the bone tunnel.

Furthermore, in the embodiment disclosed above, drill sleeve 270 is movably connected to outrigger 235 via a screw connection (i.e., screw threads 275 on the
20 exterior of drill sleeve 270 and threaded bore 240 in outrigger 235). This arrangement provides a simple and cost-effective way to movably secure drill sleeve 270

to outrigger 235. However, if desired, other types of arrangements could also be used. For example, and looking now at Figs. 35 and 36, drill sleeve 270 could have a smooth or ribbed or roughed (e.g. knurled) exterior 275A that slides through a non-threaded bore 240A in outrigger 235, with a locking pin 235A being selectively advanceable (through a threaded bore 235B) into engagement with drill sleeve 270, whereby to selectively lock the drill sleeve to the outrigger. Still other possible arrangements for selectively locking drill sleeve 270 to outrigger 235 will be apparent to those skilled in the art of drilling and drill sleeves.

Also, in the embodiment disclosed above, drill guide 210 is shown (see, for example, Fig. 14) as being releasably secured to holder 205 via a post 255 and tightening nut 290. However, it should be appreciated that other types of connections (e.g., a "quick release" clamping mechanism) may also be used to releasably secure drill guide 210 to holder 205.

It is also possible to form transverse tunnel 75 before graft ligament support block 100 and graft

ligament 35 are positioned in femoral tunnel 25. More particularly, in one possible arrangement, a reamer drill guide 200A (Fig. 37) may be used. Reamer drill guide 200A is substantially identical to the
5 installation tool 200 described above, except as will hereinafter be described. More particularly, reamer drill guide 200A comprises a reamer 205A and the drill guide 210. Reamer 205A is substantially identical to the holder 205 described above, except that it has a
10 cylindrical element 220A (Figs. 37 and 38) at its distal end having a transverse hole 220B extending therethrough, and it omits the suture posts 227 which are preferably provided on holder 205. Reamer 205A is configured so that (i) its cylindrical element 220A has
15 a diameter approximately equal to the diameter of femoral tunnel 25, and (ii) when drill guide 210 is attached to reamer 205A, the lumen 285 in drill sleeve 270 will be aligned with transverse hole 220B in reamer 205A.

20 Graft ligament support block 100, holder 205 and reamer drill guide 200A may be used to effect an ACL reconstruction as follows.

First, the surgical site is prepared for the graft ligament, e.g., by clearing away the damaged ACL, etc. Then a guidewire 400 (Fig. 17) is drilled up through tibia 10, across the interior of the knee joint.

5 Preferably guidewire 400 is stopped short of engaging the bottom of femur 15 (Fig. 18). Then a cannulated tibial drill 500 (Fig. 19) is loaded onto guidewire 400 and drilled up through tibia 10 and into the interior of the knee joint (Fig. 20). Then cannulated tibial
10 drill 500 is withdrawn back down the guidewire (Fig. 21), leaving a tibial tunnel 20.

Next, guidewire 400 is drilled an appropriate distance into the interior of femur 15. Then a
15 cannulated femoral drill 600 (e.g., an acorn drill of the type shown in Fig. 22) is loaded onto guidewire 400, passed through tibial tunnel 20, across the interior of the knee joint, and then drilled up into femur 15, stopping within the interior of femur 15. Then cannulated femoral drill 600 is withdrawn back
20 down the guidewire, leaving a femoral tunnel 25, and then guidewire 400 is withdrawn (see Fig. 39).

Next, reamer drill guide 200A is advanced so that its cylindrical element 220A is advanced through tibial tunnel 20, across the interior of the knee, and up into femoral tunnel 25. In this respect it should be appreciated that as reamer drill guide 200A is advanced through tibial tunnel 20 and femoral tunnel 25, its cylindrical element 220A will ream both bone tunnels, clearing out any intervening debris.

Once reamer drill guide 200A has been advanced into position, drill sleeve 270 is advanced into tight engagement with femur 15. This action will help stabilize reamer drill guide 200A relative to femur 15. Then a transverse tunnel drill 800 (Fig. 40) is used to drill a transverse tunnel 75 through the lateral portion of femur 15, through transverse hole 220B in cylindrical element 220A, and into the medial portion of femur 15. In this respect it will be appreciated that transverse tunnel drill 800 will be accurately and consistently directed through transverse hole 220B in cylindrical element 220A (Fig. 40) due to the fact that the relative orientation of cylindrical element 220A

and drill sleeve 270 is regulated by the pre-defined engagement of drill guide 210 with reamer 205A.

Once transverse tunnel drill 800 has been used to drill transverse tunnel 75, transverse tunnel drill 800 is removed. Then drill sleeve 270 is loosened and reamer drill guide 200A is withdrawn from the surgical site (Fig. 41).

Next, a graft ligament 35 is mounted to graft ligament support block 100 by threading one end of the graft ligament through graft hole 110, and then graft ligament support block 100 is mounted to the distal end of shaft 215, i.e., by seating fingers 220 in recesses 140. The two free ends of graft ligament 35 are preferably held taut, e.g., by passing sutures 70 through the two free ends of graft ligament 35 and then securing these sutures (e.g., by winding) to suture posts 227. This arrangement will help control the two free ends of graft ligament 35 and will help hold graft ligament support block 100 to holder 205. Then holder 205 is used to push graft ligament support block 100, and hence graft ligament 35, up through tibial tunnel 20, across the interior of the knee joint, and up into

femoral tunnel 25 (Fig. 42). As graft ligament support block is advanced in femoral tunnel 25, or after it has been advanced an appropriate distance into femoral tunnel 25, it is rotated as necessary, by turning handle 225 as necessary, so as to align the transverse fixation pin hole 115 with transverse tunnel 75. Such alignment may be facilitated by providing an alignment marker (e.g., such as the alignment marker 225A shown in Fig. 43) on handle 225.

Then transverse fixation pin 300, mounted on a driver 325, is advanced into transverse tunnel 75 and across transverse fixation pin hole 115 in graft ligament support block 100 (Fig. 44), whereby to secure graft ligament support block 100 (and hence graft ligament 35) in femoral tunnel 25. Then driver 325 is removed. Next, the two free ends of graft ligament 35 are detached from the handle's suture posts 227, and holder 205 is withdrawn. In this respect it will be appreciated that graft ligament support block 100 will be held in position in femoral tunnel 25 when holder 205 is withdrawn due to the presence of transverse fixation pin 300 in transverse tunnel 75 and transverse

fixation pin hole 115. Finally, the two free ends of graft ligament 35 then secured to tibia 10, thereby completing the ACL reconstruction procedure.

Looking next at Figs. 45 and 46, there is shown a
5 modified graft ligament support block 1500 which
comprises one preferred form of the invention. Graft
ligament support block 1500 comprises a body 1505, and
a graft hole 1510 and a transverse fixation pin hole
1515 extending through body 1505, with both graft hole
10 1510 and transverse fixation pin hole 1515 preferably
extending substantially perpendicular to the
longitudinal axis 1520 of body 1505. In one preferred
form of the invention, graft hole 1510 and transverse
fixation pin hole 1515 extend diametrically across body
15 1505, with graft hole 1510 and transverse fixation pin
hole 1515 extending substantially parallel to one
another. Preferably graft hole 1510 resides closer to
the proximal end 1525 of body 1505 than transverse
fixation pin hole 1515, and transverse fixation pin
20 hole 1515 resides closer to the distal end 1530 of body
1505 than graft hole 1510. In one preferred form of
the invention, the distal end of body 1505 has a

circular cross-section, although it may also have an oval cross-section or a polygonal cross-section (e.g., square or rectangular or triangular, etc.). In one preferred construction, the distal end of body 1505 has a cross-section sized just slightly smaller than the diameter of the bone tunnel, so as to provide a close interface between body 1505 and the walls of the bone tunnel. In one preferred form of the invention, the distal end 1530 of body 1505 is tapered so as to facilitate advancement of graft ligament support block 100 through a bone tunnel. And in a preferred form of the invention, the proximal end of body 1505 is sculpted away, e.g. such as shown at 1535, so as to provide more room for a graft ligament looped through graft hole 1510 and extending distally therefrom. Body 1505 also includes one or more recesses (not shown, but preferably similar to or analogous to the recesses 140 provided in body(105)) for mounting body 1505 to an appropriate installation tool.

If desired, graft ligament support block 1500 may also include suture hole 1545 for receiving a tow

suture, as will hereinafter be discussed in further detail.

5 Additionally, if desired, the proximal end of graft hole 1510 may be tapered as shown at 1550 so as to provide a less traumatic bearing surface for a graft ligament looped through graft hole 1510, and/or the entrance of transverse fixation pin hole 1515 may be tapered as shown at 1555 so as to facilitate entry of a transverse fixation pin into transverse fixation pin
10 hole 1515.

 Body 1505 may be formed out of a polymer, a bioabsorbable or bioremodelable material, allograft bone, a metal, a ceramic, coral, a fiber composite, a composite including at least one of the foregoing, etc.
15 By forming body 1505 out of a relatively strong material, the graft ligament can be held under tension even where body 1505 is relatively small, or where one or more of the holes 1510, 1515 and/or 1545 is located fairly close to the periphery of body 1505.

20 Still looking at Figs. 45, 46A and 46B, there is shown a tapered portion 1560 at the proximal end 1525 of body 1505. Tapered portion 1560 facilitates

retraction of graft block 1505 out of a bone tunnel if the same is needed, e.g., for an interoperative revision. This is beneficial in that other designs with squared corners tend to bind in the bone tunnel if the body is retracted proximally out of a bone tunnel.

Referring now to Figs. 46A and 46B, there is shown body 1505 having a graft hole 1510 with a length X (Fig. 46A), which is substantially equal to the width of a graft ligament. Graft hole 1510 provides an opening which is shorter than length Y of graft hole 110 of body 105 (Fig. 46B), which in turn provides increased contact of the graft with the tunnel wall.

In a preferred embodiment of the invention, there is provided a method for securing a graft ligament in a bone tunnel. The method comprises a first step of selecting a graft ligament support block with a graft hole sized substantially equal to a given width of a graft ligament. The method comprises a step of looping the graft ligament through the graft hole in the graft ligament support block. The method comprises a further step of advancing the graft ligament support block into the bone tunnel. The method comprises a step of

forming a transverse tunnel in the host bone, with a transverse tunnel being aligned with a transverse fixation pin hole in the graft ligament support block. The final step of the method comprises pinning the graft ligament support block within the bone tunnel by advancing a transverse fixation pin along the transverse tunnel in the host bone and into the transverse fixation pin hole in the graft ligament support block.

10 In another preferred embodiment of the present invention, there is provided a method for securing a graft ligament in a bone tunnel. The method comprises the step of forming a transverse tunnel in the host bone. The method comprises the step of selecting a
15 graft ligament support block with a graft hole sized substantially equal to a given width of a graft ligament. The method also comprises the step of looping the graft ligament through the graft hole in the graft ligament support block. The graft ligament
20 support block is advanced into the bone tunnel so that a transverse fixation pin hole in the graft ligament support block is aligned with the transverse tunnel.

The final step comprises pinning the graft ligament support block within the bone tunnel by advancing a transverse fixation pin along the transverse tunnel in the host bone and into the transverse fixation pin hole
5 in the graft ligament support block.

Looking now at Figs. 47 and 48, in a preferred embodiment of the present invention, there is shown a removable transverse fixation pin 1600 (Fig.47) which is configured to be used in a similar fashion as
10 transverse fixation pin 300 (Fig. 16) described hereinabove. Removable fixation pin 1600 (Fig. 47) generally comprises a solid shaft 1605 terminating in a tapered distal end 1610, and a ribbed (or barbed or threaded) section 1615. A socket 1620 is formed in the
15 proximal end of removable transverse fixation pin 1600, whereby transverse fixation pin 1600 may be engaged by a driver. Socket 1620 may be adapted to receive a rotational-type driver (e.g., a hex driver) or a mallet-type driver. Socket 1620 further includes an
20 internal tapped hole 1625 formed therein. Internal tapped hole 1625 is configured to engage a retraction tool 1630 (Fig. 48) so as to aid in the removal of

removable fixation pin 1600 from a transverse bone tunnel.

Retraction tool 1630 generally comprises a shaft 1635 having a handle 1640 at one end and a threaded projection 1645 at the other end. Threaded projection 1645 is configured for threadable engagement with internal tapped hole 1625 formed in removable fixation pin 1600. When threaded projection 1645 is securely mated with internal tapped hole 1625, removable transverse fixation pin 1600 may be withdrawn from a bone tunnel by applying appropriate forces on handle 1640.

In a preferred embodiment of the present invention, there is provided a method for revising a graft ligament in a bone tunnel. The method comprises of engaging an internal tapped hole in a transverse fixation pin with a removal tool. The method also comprises the step of withdrawing the transverse fixation pin from the bone tunnel with the removal tool engaged with the internal tapped hole. The method comprises a further step of repositioning the graft ligament support block into the bone tunnel. The

method comprises a final step of pinning the graft
ligament support block within the bone tunnel by
advancing a transverse fixation pin along a transverse
tunnel in the host bone and into the transverse
5 fixation pin hole in the graft ligament support block.

Referring now to Fig. 49, and in a preferred
embodiment of the present invention, there is shown a
stepped transverse tunnel drill 1700 having a shaft
1705 with a narrow cutting portion 1710 along a first
10 length of the distal end thereof, a wide cutting
portion 1715 along a second length proximally of the
narrow cutting portion 1710, and a discontinuous
portion 1720 formed at the junction of narrow cutting
portion 1710 and wide cutting portion 1715.

15 Looking now at Fig. 50, stepped transverse tunnel
drill 1700 is used so as to drill a stepped transverse
tunnel 1725 (Fig. 50) through the lateral portion of
femur 15, through a portion of bone tunnel 25, and into
the medial portion of femur 15 as described herein.

20 Transverse tunnel 1725 includes a narrow portion 1730
and a wide portion 1735 corresponding to narrow cutting
portion 1710 and wide cutting portion 1715 of stepped

transverse tunnel drill 1700, respectively. A stepped portion (not shown) within transverse tunnel 1725 provides an annular shoulder to stop the advancement of a transverse tunnel pin (not shown).

5 In a preferred embodiment of the present invention (not shown), there is provided a stepped fixation pin having a profile of a portion of stepped transverse tunnel drill 1700. The stepped fixation pin is preferably configured with an annular shoulder formed
10 between a narrow portion at its distal end and a wide portion at its proximal end. The annular shoulder allows the stepped fixation pin to be positionably seated at a known distance within transverse tunnel 1725 so as to position the narrow portion of the
15 stepped fixation pin within narrow portion 1730 of transverse tunnel 1725 and the wide portion of the stepped fixation pin within wide portion 1735 of transverse tunnel 1725.

 In a preferred embodiment of the present
20 invention, a method is provided for securing a graft ligament in a bone tunnel. The method comprises looping a graft ligament through a graft hole in a

graft ligament support block (not shown). The method further comprises advancing the graft ligament support block into bone tunnel 25. The method also comprises a step of forming stepped transverse tunnel 1725 (Fig. 50) in host bone 15 with stepped transverse tunnel drill 1700 (Fig. 49), with the stepped transverse tunnel 1725 (Fig. 50) being aligned with a transverse fixation pin hole (not shown) in the graft ligament support block. The method comprises a final step of pinning the graft ligament support block within bone tunnel 25 by advancing a stepped transverse fixation pin (not shown) along transverse tunnel 1725 in host bone 15 and into the transverse fixation pin hole (not shown) in the graft ligament support block (not shown).

In a preferred embodiment of the present invention, an installation tool is used to advance the graft ligament support block into the bone tunnel prior to the step of forming stepped transverse tunnel 1725 in host bone 15 (Fig. 50). Preferably, the installation tool is used together with the stepped transverse tunnel drill to form the stepped transverse tunnel in the host bone.

In another preferred embodiment to the present invention, a tow suture is used to advance the graft ligament support block into the bone tunnel prior to the step of forming stepped transverse tunnel 1725 in host bone 15 (Fig. 50).

In a preferred embodiment of the present invention, there is provided another method for securing a graft ligament in a bone tunnel. This method comprises a first step of forming a stepped transverse tunnel 1725 (Fig. 50) in host bone 15 with stepped transverse tunnel drill 1700 (Fig. 49). The method comprises a subsequent step of looping a graft ligament through a graft hole in a graft ligament support block. This is followed by the step of advancing the graft ligament support block into bone tunnel 25 so that a transverse fixation pin hole in the graft ligament support block (not shown) is aligned with the stepped transverse tunnel 1725. The method comprises a final the step of pinning the graft ligament support block within bone tunnel 25 by advancing a stepped transverse fixation pin (not shown) along the stepped transverse tunnel 1725 in host bone

15 and into the transverse fixation pin hole (not shown) in the graft ligament support block (not shown).

In a preferred embodiment of the present invention (not shown), an installation tool is used to advance
5 the graft ligament support block into the bone tunnel subsequent to the steps of forming the stepped transverse tunnel and looping the graft ligament through the graft hole.

Referring now to Figs. 51A, 51B and 52, and in a
10 preferred embodiment of the present invention, there is shown a calibrated graft ligament reconstruction system 1740 (Fig. 52) which generally includes a holder 1745 and an associated drill guide 1750.

Drill guide 1750 has a similar configuration to
15 drill guide 210 described hereinabove. Preferably, drill guide 1750 comprises an outrigger 1755 having a smooth bore 1760 formed in its distal end 1765 and sized to receive a drill sleeve 1770 therein. A first set of depth markers 1775 disposed on drill sleeve 1770
20 are configured to indicate the distance from a distal tip 1780 of the drill sleeve 1770 to a preselected portion within femur 15. Preferably, depth markers

1775 are read relative to a proximal opening 1785 of smooth bore 1760.

Referring now to Figs. 51B and 52, and in a preferred embodiment of the present invention, there is shown stepped transverse drill 1700 having a second set of depth markers 1790 thereon. Depth markers 1790 are configured to indicate the distance to the preselected portion within femur 15. Preferably, depth markers 1790 are read relative to a proximal opening 1795 (Fig. 52) of drill sleeve 1770.

In a preferred embodiment of the present invention, a method is disclosed for securing a graft ligament in a bone tunnel. The method comprises a first step of looping a graft ligament through a graft hole in a graft ligament support block. The method comprises a subsequent step of advancing the graft ligament support block into the bone tunnel. This step is followed by the step of positioning a drill guide in attachment to the graft support block, the drill guide comprising an outrigger and a drill sleeve moveably attached to the outrigger, and the drill sleeve having depth markers thereon. The method further comprises a

step of determining a proper transverse tunnel depth with the drill sleeve and the outrigger by moving the drill sleeve within the outrigger toward the bone tunnel and reading the depth markers on the drill sleeve. The method comprises the step of forming a transverse tunnel in the host bone to a proper transverse tunnel depth by drilling a transverse tunnel drill to a given depth according to markers disposed on thereon, with the transverse tunnel being aligned with a transverse fixation pin hole in the graft ligament support block. The method comprises a final step of pinning the graft ligament support block within the bone tunnel by advancing a transverse fixation pin along the transverse tunnel in the host bone and into the transverse fixation pin hole in the graft ligament support block.

In another preferred embodiment of the present invention, a method is disclosed for securing a graft ligament in a bone tunnel. The method comprises a first step of positioning a drill guide in attachment to a bone tunnel guide inserted into the bone tunnel, the drill guide comprising an outrigger and a drill

sleeve moveably attached to the outrigger, and the drill sleeve having depth markers thereon. The method comprises a subsequent step of determining a proper transverse tunnel depth with the drill sleeve and the outrigger by moving the drill sleeve within the

5 outrigger toward the bone tunnel and reading the depth markers on the drill sleeve. The method comprises the step of forming a transverse tunnel in the host bone to a proper transverse tunnel depth by drilling a

10 transverse tunnel drill to a given depth according to markers disposed thereon. The method calls for the step of looping a graft ligament through a graft hole in a graft ligament support block. The method comprises the step of advancing the graft ligament

15 support block into the bone tunnel so that a transverse fixation pin hole in the graft ligament support block is aligned with the transverse tunnel. The method comprises a final step of pinning the graft ligament support block within the bone tunnel by advancing a

20 transverse fixation pin along the transverse tunnel in the host bone and into the transverse fixation pin hole in the graft ligament support block.

Looking at Figs. 53 and 54, and in a preferred embodiment of the present invention, there is shown a depth limiting transverse tunnel drill 1800 having a stop element 1805 disposed thereon. Drill 1800 may have anyone of the many tips known in the orthopedic art, e.g., a standard fluted tip, a trocar tip, and a spade tip, etc. Stop element 1805 is placed at a position along the length of depth limiting transverse tunnel drill 1800 so as to limit the depth of penetration of a distal tip 1810 of transverse tunnel drill 1800 into femur 15 (Fig. 54). Stop element 1805 limits the distal penetration of transverse tunnel drill 1800 by engaging outrigger 1755 at distal end 1765 adjacent to proximal opening 1785, which allow only a distal portion 1815 to pass therethrough.

In a preferred embodiment of the present invention, stop element 1805 is adjustably or fixedly positioned along a portion of depth limiting transverse tunnel drill 1800 and further comprises a locking device so as to selectively determine the depth of penetration of transverse tunnel drill 1800 into femur 15.

Referring now to Figs. 55 and 56, and in a preferred embodiment of the present invention, there is shown a depth gauge 1900 with a series of depth gauge markings 1905 configured thereon. Depth gauge 1900 is configured to engage a transverse fixation pin 1910 at a distal end 1915 thereof for insertion and proper placement into femur 15 (Fig. 56). Depth gauge markings 1905 of depth gauge 1900 indicate the position of distal end 1915, and hence the proximal end of the depth gauge, within femur 15. Preferably, depth gauge markings 1905 are read relative to proximal opening 1795 of drill sleeve 1775, which inserter 1900 passes therethrough.

Referring to Fig. 52, and in a preferred embodiment of the present invention, a method is disclosed for securing a graft ligament in a bone tunnel. The method comprises a first step of looping a graft ligament through a graft hole in a graft ligament support block. This step is followed by the step of advancing the graft ligament support block into the bone tunnel. The method comprises a further step of determining a proper transverse tunnel depth by reading

a position of depth markers 1775 on drill sleeve 1770 relative to outrigger 1755. The method comprises a subsequent step of forming a transverse tunnel in the host bone using transverse tunnel drill 1770 having
5 depth markers 1790 thereon so as to drill the transverse tunnel to the proper transverse tunnel depth, transverse is aligned a transverse fixation pin hole in the graft ligament support block. The method comprises a final step of pinning the graft ligament
10 support block within the bone tunnel by selecting a transverse fixation pin based on the proper transverse tunnel depth determined by depth markers 1775 on drill sleeve 1770 and advancing the selected transverse fixation pin along the transverse tunnel in the host
15 bone and into the transverse fixation pin hole in the graft ligament support block.

Referring still to Fig. 52, and in a preferred embodiment of the present invention, a method is disclosed for securing a graft ligament in a bone
20 tunnel. The method comprises a first step of determining a proper transverse tunnel depth by reading a position of depth markers 1775 on drill sleeve 1770

relative to outrigger 1755. The method comprises a further step of forming a transverse tunnel in the host bone using transverse tunnel drill 1700 having depth markers 1790 thereon so as to drill the transverse tunnel to the proper transverse tunnel depth. The method comprises a subsequent step of looping a graft ligament through a graft hole in a graft ligament support block. This step is followed by the step of advancing the graft ligament support block into the bone tunnel so that a transverse fixation pin hole in the graft ligament support block is aligned with the transverse tunnel. The method comprises a final step of pinning the graft ligament support block within the bone tunnel by selecting a transverse fixation pin based on the proper transverse tunnel depth determined by depth markers 1775 on drill sleeve 1770 and advancing a transverse fixation pin along the transverse tunnel in the host bone and into the transverse fixation pin hole in the graft ligament support block.

Referring now to Figs. 53 and 54, and in a preferred embodiment of the present invention, a method

is disclosed for securing a graft ligament in a bone tunnel. The method comprises a first step of looping a graft ligament through a graft hole in a graft ligament support block. The method comprises a subsequent step of advancing the graft ligament support block into the bone tunnel. The method comprises another step of forming a transverse tunnel in host bone to a predetermined depth using transverse tunnel drill having stop element at a predetermined distance from the distal end thereof, and stop element is configured to engage drill sleeve or distal end of outrigger so as to limit drilling to the predetermined depth, with said transverse tunnel being aligned with a transverse fixation pin hole in the graft ligament support block. The method comprises a final step of pinning the graft ligament support block within the bone tunnel by advancing a transverse fixation pin along the transverse tunnel in the host bone and into the transverse fixation pin hole in the graft ligament support block.

Referring still to Figs. 53 and 54, and in a preferred embodiment of the present invention, a method

is disclosed for securing a graft ligament in a bone tunnel. The method comprises a first step of forming a transverse tunnel in host bone 15 to a predetermined depth using transverse tunnel drill 1800 having stop element 1805 at a predetermined distance from the distal end thereof, and stop element 1805 configured to engage a drill sleeve or distal end 1765 of outrigger 1755 so as to limit drilling to the predetermined depth. The method comprises a subsequent step of looping a graft ligament through a graft hole in a graft ligament support block. The method comprises a further step of advancing the graft ligament support block into the bone tunnel so that a transverse fixation pin hole in the graft ligament support block is aligned with the transverse tunnel. The method comprises a final step of pinning the graft ligament support block within the bone tunnel by advancing a transverse fixation pin along the transverse tunnel in the host bone and into the transverse fixation pin hole in the graft ligament support block.

In a preferred embodiment of the present invention (not shown), a modified graft ligament support block

similar to support block 1500 (Fig. 45) and support
block 100 (Fig. 8) is provided for supporting a graft
ligament in a bone tunnel. The modified graft ligament
support block comprises a region configured therein for
5 drilling a transverse fixation pin hole through the
body transverse to the longitudinal axis as a crosspin
hole is drilled through the bone tunnel. Preferably,
the modified graft ligament support block further
comprises a tapered proximal end so as to facilitate
10 withdrawal of the graft ligament support block through
the bone tunnel.

In the preceding discussion, the present invention
has been discussed on the context of an ACL
reconstruction. However, it should also be appreciated
15 that the present invention may also be used in
connection with the other types of ligament
reconstructions and/or other types of anatomical
reconstructions.

What Is Claimed Is:

1. Apparatus for use in reconstructing a ligament, said apparatus comprising:

5 a graft ligament support block for supporting a graft ligament in a bone tunnel, said graft ligament support block comprising:

10 a body having a distal end, a proximal end, and a longitudinal axis extending between said distal end and said proximal end, said proximal end being tapered so as to facilitate withdrawal of said graft ligament support block through a bone tunnel;

15 a graft hole extending through said body transverse to said longitudinal axis and configured to receive a graft ligament therein; and

a transverse fixation pin hole extending through said body transverse to said longitudinal axis and configured to receive a transverse fixation pin therein.

2. Apparatus according to claim 1 wherein said graft hole resides closer to said proximal end of said body than said transverse fixation pin hole.

5 3. Apparatus according to claim 1 wherein at least a portion of an opening of said graft hole is tapered so as to provide a less traumatic bearing surface for a graft ligament looped through said graft hole.

10 4. Apparatus according to claim 1 wherein an opening of said transverse fixation pin hole is tapered so as to facilitate entry of a transverse fixation pin into said transverse fixation pin hole.

15 5. Apparatus according to claim 1 wherein at least a portion of said body between said graft hole and said transverse fixation pin hole has a substantially cylindrical cross-section.

20 6. Apparatus according to claim 1 wherein said distal end of said body is tapered so as to facilitate

advancement of said graft ligament support block through the bone tunnel.

5 7. Apparatus according to claim 1 wherein said proximal end of said body is sculpted away so as to provide more room for a graft ligament looped through said graft hole and extending proximally therefrom.

10 8. Apparatus according to claim 7 wherein said proximal end of said body is sculpted away so as to form at least one substantially planar surface.

15 9. Apparatus according to claim 7 wherein said proximal end of said body is sculpted away so as to form at least one surface groove extending between said graft hole and said proximal end of said body.

20 10. Apparatus according to claim 1 wherein said body is formed out of a material selected from the group consisting of a polymer, a bioabsorbable material, a bioremodelable material, allograft bone, a

metal, a ceramic, coral, a fiber composite, and a composite including at least one of the foregoing.

5 11. Apparatus according to claim 1 wherein said body further comprises at least one element for engagement by an installation tool.

10 12. Apparatus according to claim 11 wherein said at least one element comprises an opening formed in said proximal end of said body and adapted for engagement by a finger formed on the installation tool.

.5 13. Apparatus according to claim 11 wherein said at least one element comprises a finger extending proximally from said proximal end of said body and adapted for engagement in an opening formed on the installation tool.

0 14. Apparatus according to claim 1 wherein said body further comprises a suture hole extending through said body transverse to said longitudinal axis and configured to receive a tow suture therein.

15. Apparatus according to claim 14 wherein said suture hole resides closer to said distal end of said body than said transverse fixation pin hole.

5

16. Apparatus according to claim 1 further comprising an installation tool, said installation tool comprising:

a holder, said holder comprising:

10 a shaft having a distal end, a proximal end and longitudinal axis extending between said distal end and said proximal end, said proximal end of said shaft comprising at least one finger for engagement in said opening; and

15 a handle mounted to said proximal end of said shaft.

17. Apparatus according to claim 16 further comprising at least one suture post formed on said proximal end of said shaft.

20

18. Apparatus according to claim 16 wherein said installation tool further comprises a drill guide adapted to be releasably secured to said holder.

5 19. Apparatus according to claim 18 wherein said drill guide comprises:

an outrigger comprising a distal end and a proximal end, with said proximal end of said outrigger being configured to be releasably secured to said holder; and

10 a drill sleeve moveably attached to said distal end of said outrigger, said drill sleeve comprising a drilling lumen extending therethrough.

15 20. Apparatus according to claim 19 wherein said installation tool is configured so that when said graft ligament support block is attached to said distal end of said shaft, said drilling lumen in said drill guide is aligned with said transverse fixation pin hole in

20 said body.

21. Apparatus according to claim 16 wherein said proximal end of said holder comprises an orientation marker for visually indicating the axial orientation of said distal end of said shaft.

5

22. A method for securing a graft ligament in a bone tunnel, comprising the steps of:

(1) looping a graft ligament through a graft hole in a graft ligament support block, advancing the graft ligament support block into the bone tunnel, withdrawing the graft ligament support block back down the bone tunnel, advancing a graft ligament support block into the bone tunnel, with a graft ligament being looped through a graft hole in the graft ligament support block, and forming a transverse tunnel in the host bone, with a transverse fixation pin hole in the graft ligament support block being aligned with the transverse tunnel in the host bone; and

(2) pinning the graft ligament support block within the bone tunnel by advancing a transverse fixation pin along the transverse tunnel in the host

20

bone and into the transverse fixation pin hole in the
graft ligament support block.

23. A method according to claim 22 wherein an
5 installation tool is used to advance the graft ligament
support block into the bone tunnel.

24. A method according to claim 23 wherein the
the graft ligament support block is withdrawn from the
10 bone tunnel by pulling back on the graft ligament.

25. A method according to claim 23 wherein the
two free ends of the graft ligament are secured to the
installation tool prior to advancing the graft ligament
.5 support block into the bone tunnel.

26. A method according to claim 23 wherein the
installation tool is used to form the transverse tunnel
in the host bone.
0

27. A method according to claim 22 wherein a tow suture is used to advance the graft ligament support block into the bone tunnel.

5 28. A method for revising a graft ligament in a bone tunnel, said method comprising the steps of:
 unpinning a graft ligament support block within a bone tunnel by withdrawing a transverse fixation pin from a transverse fixation pin hole in the graft
10 ligament support block and from a transverse tunnel a host bone;

 withdrawing the graft ligament support block back down the bone tunnel;

 advancing a graft ligament support block into the
.5 bone tunnel so that a transverse fixation pin hole in the support block is aligned with the transverse tunnel; and

 pinning the graft ligament support block within
0 the bone tunnel by advancing the transverse fixation pin along the transverse tunnel in the host bone and into the transverse fixation pin hole in the graft
 ligament support block.

29. A method according to claim 28 wherein the
graft ligament support block is withdrawn from the bone
tunnel by pulling back on a graft ligament attached to
5 the graft ligament support block.

30. A method according to claim 28 wherein the
installation tool is used to advance the graft ligament
support block into the bone tunnel.

10

31. A method according to claim 30 wherein the
two free ends of the graft ligament are secured to the
installation tool prior to advancing the graft ligament
support block into the bone tunnel.

15

32. Apparatus for use in reconstructing a
ligament, said apparatus comprising:

a graft ligament support block for supporting a
20 graft ligament in a bone tunnel, said graft ligament
support block comprising:

a body having a distal end, a proximal end,
and a longitudinal axis extending between said distal
end and said proximal end;

a graft hole extending through said body
5 transverse to said longitudinal axis and configured to
receive a graft ligament therein, said graft hole
having a given length along said longitudinal axis,
said given length being substantially equal to a given
cross-sectional dimension of the graft ligament; and

10 a transverse fixation pin hole extending
through said body transverse to said longitudinal axis
and configured to receive a transverse fixation pin
therein.

15 33. Apparatus according to claim 32 wherein said
graft hole resides between said proximal end of said
body and said transverse fixation hole, and said graft
hole resides adjacent to said transverse fixation pin
hole so as to allow a given length of the graft
0 ligament to fit into a bone tunnel, wherein said given
length of the graft ligament disposed within the bone

tunnel is maximized as said given length of said graft hole is substantially equal to the given cross-sectional dimension of the graft ligament and said graft hole is positioned adjacent to said transverse fixation pin hole.

5

34. Apparatus according to claim 32 wherein at least a portion of an opening of said graft hole is tapered so as to provide a less traumatic bearing surface for a graft ligament looped through said graft hole.

10

35. Apparatus according to claim 32 wherein an opening of said transverse fixation pin hole is tapered so as to facilitate entry of a transverse fixation pin into said transverse fixation pin hole.

15

36. Apparatus according to claim 32 wherein at least a portion of said body between said graft hole and said transverse fixation pin hole has a substantially cylindrical cross-section.

20

37. Apparatus according to claim 32 wherein said distal end of said body is tapered so as to facilitate advancement of said graft ligament support block through a bone tunnel.

5

38. Apparatus according to claim 32 wherein said proximal end of said body is sculpted away so as to provide more room for a graft ligament looped through said graft hole and extending proximally therefrom.

10

39. Apparatus according to claim 38 wherein said proximal end of said body is sculpted away so as to form at least one substantially planar surface.

.5

40. Apparatus according to claim 38 wherein said proximal end of said body is sculpted away so as to form at least one surface groove extending between said graft hole and said proximal end of said body.

0

41. Apparatus according to claim 32 wherein said body is formed out of a material selected from the group consisting of a polymer, a bioabsorbable

material, a bioremodelable material, allograft bone, a metal, a ceramic, coral, a fiber composite, and a composite including at least one of the foregoing.

5 42. Apparatus according to claim 32 wherein said body further comprises at least one element for engagement by an installation tool.

.0 43. Apparatus according to claim 42 wherein said at least one element comprises an opening formed in said proximal end of said body and adapted for engagement by a finger formed on the installation tool.

5 44. Apparatus according to claim 42 wherein said at least one element comprises a finger extending proximally from said proximal end of said body and adapted for engagement in an opening formed on the installation tool.

0 45. Apparatus according to claim 32 wherein said body further comprises a suture hole extending through

said body transverse to said longitudinal axis and configured to receive a tow suture therein.

5 46. Apparatus according to claim 45 wherein said suture hole resides closer to said distal end of said body than said transverse fixation pin hole.

10 47. Apparatus according to claim 32 further comprising an installation tool, said installation tool comprising:

a holder, said holder comprising:

.5 a shaft having a distal end, a proximal end and longitudinal axis extending between said distal end and said proximal end, said proximal end of said shaft comprising at least one finger for engagement in said opening; and

a handle mounted to said proximal end of said shaft.

0 48. Apparatus according to claim 47 further comprising at least one suture post formed on said proximal end of said shaft.

49. Apparatus according to claim 47 wherein said installation tool further comprises a drill guide adapted to be releasably secured to said holder.

5

50. Apparatus according to claim 47 wherein said drill guide comprises:

an outrigger comprising a distal end and a proximal end, with said proximal end of said outrigger being configured to be releasably secured to said holder; and

.0

a drill sleeve moveably attached to said distal end of said outrigger, said drill sleeve comprising a drilling lumen extending therethrough.

5

51. Apparatus according to claim 50 wherein said installation tool is configured so that when said graft ligament support block is attached to said distal end of said shaft, said drilling lumen in said drill guide is aligned with said transverse fixation pin hole in said body.

0

52. Apparatus according to claim 47 wherein said proximal end of said holder comprises an orientation marker for visually indicating the axial orientation of said distal end of said shaft.

5

53. A method for securing a graft ligament in a bone tunnel, comprising the steps of:

selecting a graft ligament support block with a graft hole sized substantially equal to a given cross-sectional dimension of a graft ligament;

10

looping the graft ligament through the graft hole in a graft ligament support block;

advancing the graft ligament support block into the bone tunnel;

15

forming a transverse tunnel in the host bone, with a transverse tunnel being aligned with a transverse fixation pin hole in the graft ligament support block; and

20

pinning the graft ligament support block within the bone tunnel by advancing a transverse fixation pin along the transverse tunnel in the host bone and into

the transverse fixation pin hole in the graft ligament support block.

54. A method according to claim 53 wherein an
5 installation tool is used to advance the graft ligament support block into the bone tunnel.

55. A method according to claim 53 wherein the
two free ends of the graft ligament are secured to the
10 installation tool prior to advancing the graft ligament support block into the bone tunnel.

56. A method according to claim 53 wherein the
installation tool is used to form the transverse tunnel
5 in the host bone.

57. A method according to claim 53 wherein a tow
suture is used to advance the graft ligament support
block into the bone tunnel.

0
58. A method for securing a graft ligament in a
bone tunnel, said method comprising the steps of:

forming a transverse tunnel in the host bone;

selecting a graft ligament support block with a graft hole sized substantially equal to a given cross-sectional dimension of a graft ligament;

5 looping the graft ligament through the graft hole in the graft ligament support block;

advancing the graft ligament support block into the bone tunnel so that a transverse fixation pin hole in the graft ligament support block is aligned with the transverse tunnel; and

0 pinning the graft ligament support block within the bone tunnel by advancing a transverse fixation pin along the transverse tunnel in the host bone and into the transverse fixation pin hole in the graft ligament support block.

5

59. A method according to claim 58 wherein an installation tool is used to advance the graft ligament support block into the bone tunnel.

)

60. A method according to claim 58 wherein the two free ends of the graft ligament are secured to the

installation tool prior to advancing the graft ligament support block into the bone tunnel.

61. Apparatus for use in reconstructing a
5 ligament, said apparatus comprising:

a graft ligament support block for supporting a
graft ligament in a bone tunnel, said graft ligament
support block comprising:

10 a body having a distal end, a proximal end,
and a longitudinal axis extending between said distal
end and said proximal end;

a graft hole extending through said body
transverse to said longitudinal axis and configured to
receive a graft ligament therein; and

5 a transverse fixation pin hole extending
through said body transverse to said longitudinal axis
and configured to receive a transverse fixation pin
therein; and

0 a transverse fixation pin having a proximal end
and a distal end, and said proximal end forming an
internal tapped hole therein so as to aid removal of
said transverse fixation pin from the bone tunnel.

62. Apparatus according to claim 61 wherein said internal tapped hole is configured within a drive socket at said proximal end of said fixation pin.

5

63. Apparatus according to claim 62 wherein said drive socket is configured to receive a hex driver.

64. Apparatus according to claim 62 wherein said drive socket is configured to receive a mallet driver.

0

65. Apparatus according to claim 61 wherein said graft hole resides closer to said proximal end of said body than said transverse fixation pin hole.

5

66. Apparatus according to claim 61 wherein at least a portion of an opening of said graft hole is tapered so as to provide a less traumatic bearing surface for a graft ligament looped through said graft hole.

6

67. Apparatus according to claim 61 wherein an opening of said transverse fixation pin hole is tapered so as to facilitate entry of a transverse fixation pin into said transverse fixation pin hole.

5

68. Apparatus according to claim 61 wherein at least a portion of said body between said graft hole and said transverse fixation pin hole has a substantially cylindrical cross-section.

.0

69. Apparatus according to claim 61 wherein said distal end of said body is tapered so as to facilitate advancement of said graft ligament support block through a bone tunnel.

5

70. Apparatus according to claim 61 wherein said proximal end of said body is sculpted away so as to provide more room for a graft ligament looped through said graft hole and extending proximally therefrom.

)

71. Apparatus according to claim 70 wherein said proximal end of said body is sculpted away so as to form at least one substantially planar surface.

5 72. Apparatus according to claim 70 wherein said proximal end of said body is sculpted away so as to form at least one surface groove extending between said graft hole and said proximal end of said body.

10 73. Apparatus according to claim 61 wherein said body is formed out of a material selected from the group consisting of a polymer, a bioabsorbable material, a bioremodelable material, allograft bone, a metal, a ceramic, coral, a fiber composite, and a
15 composite including at least one of the foregoing.

74. Apparatus according to claim 61 wherein said body further comprises at least one element for engagement by an installation tool.

20 75. Apparatus according to claim 74 wherein said at least one element comprises an opening formed in

said proximal end of said body and adapted for engagement by a finger formed on the installation tool.

5 76. Apparatus according to claim 74 wherein said at least one element comprises a finger extending proximally from said proximal end of said body and adapted for engagement in an opening formed on the installation tool.

.0 77. Apparatus according to claim 61 wherein said body further comprises a suture hole extending through said body transverse to said longitudinal axis and configured to receive a tow suture therein.

5 78. Apparatus according to claim 77 wherein said suture hole resides closer to said distal end of said body than said transverse fixation pin hole.

0 79. Apparatus according to claim 61 further comprising an installation tool, said installation tool comprising:

a holder, said holder comprising:

a shaft having a distal end, a proximal end and longitudinal axis extending between said distal end and said proximal end, said proximal end of said shaft comprising at least one finger for engagement in said opening; and

a handle mounted to said proximal end of said shaft.

80. Apparatus according to claim 79 further comprising at least one suture post formed on said proximal end of said shaft.

81. Apparatus according to claim 79 wherein said installation tool further comprises a drill guide adapted to be releasably secured to said holder.

82. Apparatus according to claim 81 wherein said drill guide comprises:

an outrigger comprising a distal end and a proximal end, with said proximal end of said outrigger being configured to be releasably secured to said holder; and

a drill sleeve moveably attached to said distal end of said outrigger, said drill sleeve comprising a drilling lumen extending therethrough.

5 83. Apparatus according to claim 82 wherein said installation tool is configured so that when said graft ligament support block is attached to said distal end of said shaft, said drilling lumen in said drill guide is aligned with said transverse fixation pin hole in
10 said body.

 84. Apparatus according to claim 79 wherein said proximal end of said holder comprises an orientation marker for visually indicating the axial orientation of
.5 said distal end of said shaft.

 85. A method for revising a graft ligament in a bone tunnel, comprising the steps of:

 engaging an internal tapped hole in transverse
0 fixation pin with a removal tool;

 withdrawing the transverse fixation pin from the bone tunnel with the removal tool engaged with the

internal tapped hole, and withdrawing a graft ligament support block back down the bone tunnel;

positioning a graft ligament support block into the bone tunnel;

5 pinning the graft ligament support block within the bone tunnel by advancing a transverse fixation pin along a transverse tunnel in the host bone and into the transverse fixation pin hole in the graft ligament support block.

10

86. A method according to claim 85 wherein the installation tool is used to advance the graft ligament support block into the bone tunnel.

15

87. A method according to claim 86 wherein the two free ends of the graft ligament are secured to the installation tool prior to advancing the graft ligament support block into the bone tunnel.

20

88. A method according to claim 85 wherein a tow suture is used to advance the graft ligament support block into the bone tunnel.

89. A system for use in reconstructing a ligament, said system comprising:

5 a graft ligament support block for supporting a graft ligament in a bone tunnel, said graft ligament support block comprising:

a body having a distal end, a proximal end, and a longitudinal axis extending between said distal end and said proximal end;

10 a graft hole extending through said body transverse to said longitudinal axis and configured to receive a graft ligament therein;

15 a stepped fixation pin having a distal end, a proximal end, a longitudinal axis extending between said distal end and said proximal end, a first portion at said distal end, a second portion at said proximal end, said first portion having a smaller diameter than second portion, and an annular shoulder configured between said first portion and said second portion, 20 wherein said first portion, said second portion and said annular shoulder form a given profile in a cross-

section of a given plane perpendicular to the longitudinal axis; and

5 a stepped transverse tunnel drill having a distal end, a proximal end, and a longitudinal axis extending between said distal end and said proximal end, said stepped transverse drill corresponding to said given profile of said stepped fixation pin so as to provide a stepped transverse tunnel through a portion of the bone tunnel configured to align with a pathway of said
10 transverse fixation pin hole, wherein said transverse fixation pin hole extends through said body transverse to said longitudinal axis and is configured to receive a transverse fixation pin therein.

5 90. Apparatus according to claim 89 wherein said graft hole resides closer to said proximal end of said body than said transverse fixation pin hole.

0 91. Apparatus according to claim 89 wherein at least a portion of an opening of said graft hole is tapered so as to provide a less traumatic bearing

surface for a graft ligament looped through said graft hole.

5 92. Apparatus according to claim 89 wherein an opening of said transverse fixation pin hole is tapered so as to facilitate entry of a transverse fixation pin into said transverse fixation pin hole.

10 93. Apparatus according to claim 89 wherein at least a portion of said body between said graft hole and said transverse fixation pin hole has a substantially cylindrical cross-section.

15 94. Apparatus according to claim 89 wherein said distal end of said body is tapered so as to facilitate advancement of said graft ligament support block through a bone tunnel.

20 95. Apparatus according to claim 89 wherein said proximal end of said body is sculpted away so as to provide more room for a graft ligament looped through said graft hole and extending proximally therefrom.

96. Apparatus according to claim 95 wherein said proximal end of said body is sculpted away so as to form at least one substantially planar surface.

5

97. Apparatus according to claim 95 wherein said proximal end of said body is sculpted away so as to form at least one surface groove extending between said graft hole and said proximal end of said body.

0

98. Apparatus according to claim 89 wherein said body is formed out of a material selected from the group consisting of a polymer, a bioabsorbable material, a bioremodelable material, allograft bone, a metal, a ceramic, coral, a fiber composite, and a composite including at least one of the foregoing.

5

99. Apparatus according to claim 89 wherein said body further comprises at least one element for engagement by an installation tool.

0

100. Apparatus according to claim 99 wherein said
at least one element comprises an opening formed in
said proximal end of said body and adapted for
engagement by a finger formed on the installation tool.

5

101. Apparatus according to claim 99 wherein said
at least one element comprises a finger extending
proximally from said proximal end of said body and
adapted for engagement in an opening formed on the
installation tool.

10

102. Apparatus according to claim 89 wherein said
body further comprises a suture hole extending through
said body transverse to said longitudinal axis and
configured to receive a tow suture therein.

15

103. Apparatus according to claim 102 wherein said
suture hole resides closer to said distal end of said
body than said transverse fixation pin hole.

20

104. Apparatus according to claim 89 further comprising an installation tool, said installation tool comprising:

a holder, said holder comprising:

5 a shaft having a distal end, a proximal end and longitudinal axis extending between said distal end and said proximal end, said proximal end of said shaft comprising at least one finger for engagement in said opening; and

10 a handle mounted to said proximal end of said shaft.

105. Apparatus according to claim 104 further comprising at least one suture post formed on said proximal end of said shaft.

15 106. Apparatus according to claim 104 wherein said installation tool further comprises a drill guide adapted to be releasably secured to said holder.

20 107. Apparatus according to claim 106 wherein said drill guide comprises:

an outrigger comprising a distal end and a proximal end, with said proximal end of said outrigger being configured to be releasably secured to said holder; and

5 a drill sleeve moveably attached to said distal end of said outrigger, said drill sleeve comprising a drilling lumen extending therethrough.

10 108. Apparatus according to claim 107 wherein said installation tool is configured so that when said graft ligament support block is attached to said distal end of said shaft, said drilling lumen in said drill guide is aligned with said transverse fixation pin hole in said body.

5 109. Apparatus according to claim 104 wherein said proximal end of said holder comprises an orientation marker for visually indicating the axial orientation of said distal end of said shaft.

0 110. A method for securing a graft ligament in a bone tunnel, comprising the steps of:

looping a graft ligament through a graft hole in a graft ligament support block;

advancing the graft ligament support block into the bone tunnel;

5 forming a stepped transverse tunnel in the host bone with a stepped transverse tunnel drill, with the stepped transverse tunnel being aligned with a transverse fixation pin hole in the graft ligament support block; and

10 pinning the graft ligament support block within the bone tunnel by advancing a stepped transverse fixation pin along the transverse tunnel in the host bone and into the transverse fixation pin hole in the graft ligament support block.

15 111. A method according to claim 110 wherein an installation tool is used to advance the graft ligament support block into the bone tunnel.

0 112. A method according to claim 111 wherein the two free ends of the graft ligament are secured to the

installation tool prior to advancing the graft ligament support block into the bone tunnel.

5 113. A method according to claim 112 wherein the installation tool is used together with the stepped transverse tunnel drill to form the stepped transverse tunnel in the host bone.

10 114. A method according to claim 110 wherein a tow suture is used to advance the graft ligament support block into the bone tunnel.

115. A method for securing a graft ligament in a bone tunnel, said method comprising the steps of:

5 forming a stepped transverse tunnel in the host bone with a stepped transverse tunnel drill;

looping a graft ligament through a graft hole in a graft ligament support block;

10 advancing the graft ligament support block into the bone tunnel so that a transverse fixation pin hole in the graft ligament support block is aligned with the stepped transverse tunnel; and

pinning the graft ligament support block within
the bone tunnel by advancing a stepped transverse
fixation pin along the stepped transverse tunnel in the
host bone and into the transverse fixation pin hole in
5 the graft ligament support block.

116. A method according to claim 115 wherein an
installation tool is used to advance the graft ligament
support block into the bone tunnel.

10

117. A method according to claim 116 wherein the
two free ends of the graft ligament are secured to the
installation tool prior to advancing the graft ligament
support block into the bone tunnel.

15

118. A system for use in reconstructing a
ligament, said system comprising:

a graft ligament support block for supporting a
graft ligament in a bone tunnel, said graft ligament
support block comprising:

20

a body having a distal end, a proximal end, a
longitudinal axis extending between said distal end and

said proximal end, and at least one element for engagement by an installation tool;

a graft hole extending through said body transverse to said longitudinal axis and configured to receive a graft ligament therein; and

a transverse fixation pin hole extending through said body transverse to said longitudinal axis and configured to receive a transverse fixation pin therein;

an installation tool comprising:

a holder, said holder comprising:

a shaft having a distal end, a proximal end, and a longitudinal axis extending between said distal end and said proximal end, said proximal end of said shaft configured to engage said at least one element of said body;

a handle mounted to said proximal end of said shaft;

a drill guide adapted to be releasably secured to said holder, said drill guide comprising:

an outrigger comprising a distal end and a proximal end, said proximal end of said outrigger configured to be releasably secured to said holder; and

5 a drill sleeve moveably attached to said distal end of said outrigger, said drill sleeve comprising a drilling lumen extending therethrough, and said drill sleeve having depth markers thereon, wherein said distal end of said outrigger and said depth markers on said drill sleeve are configured so as to
.0 indicate a proper transverse tunnel depth; and

a transverse tunnel drill having a distal end and a proximal end, said distal end of said transverse tunnel drill configured for placement through said drill sleeve so as to drill a transverse bone tunnel
5 through the bone tunnel, said transverse tunnel drill having markers disposed thereon between said proximal end and the distal end thereof, wherein said depth markers on said transverse tunnel drill and said drill sleeve are configured so as to indicate a given depth
0 of said distal end of said transverse tunnel drill.

119. A system according to claim 118 wherein said graft hole resides closer to said proximal end of said body than said transverse fixation pin hole.

5 120. A system according to claim 118 wherein at least a portion of an opening of said graft hole is tapered so as to provide a less traumatic bearing surface for a graft ligament looped through said graft hole.

10 121. A system according to claim 118 wherein an opening of said transverse fixation pin hole is tapered so as to facilitate entry of a transverse fixation pin into said transverse fixation pin hole.

15 122. A system according to claim 118 wherein at least a portion of said body between said graft hole and said transverse fixation pin hole has a substantially cylindrical cross-section.

20 123. A system according to claim 118 wherein said distal end of said body is tapered so as to facilitate

advancement of said graft ligament support block through a bone tunnel.

5 124. A system according to claim 118 wherein said proximal end of said body is sculpted away so as to provide more room for a graft ligament looped through said graft hole and extending proximally therefrom.

10 125. A system according to claim 124 wherein said proximal end of said body is sculpted away so as to form at least one substantially planar surface.

15 126. A system according to claim 124 wherein said proximal end of said body is sculpted away so as to form at least one surface groove extending between said graft hole and said proximal end of said body.

20 127. A system according to claim 118 wherein said body is formed out of a material selected from the group consisting of a polymer, a bioabsorbable material, a bioremodelable material, allograft bone, a

metal, a ceramic, coral, a fiber composite, and a composite including at least one of the foregoing.

5 128. A system according to claim 118 wherein said at least one element comprises an opening formed in said proximal end of said body and adapted for engagement by a finger formed on the installation tool.

10 129. A system according to claim 118 wherein said at least one element comprises a finger extending proximally from said proximal end of said body and adapted for engagement in an opening formed on the installation tool.

15 130. A system according to claim 118 wherein said body further comprises a suture hole extending through said body transverse to said longitudinal axis and configured to receive a tow suture therein.

20 131. A system according to claim 130 wherein said suture hole resides closer to said distal end of said body than said transverse fixation pin hole.

132. A system according to claim 118 wherein said
installation tool is configured so that when said graft
ligament support block is attached to said distal end
of said shaft, said drilling lumen in said drill guide
is aligned with said transverse fixation pin hole in
said body.

133. A system according to claim 118 wherein said
proximal end of said holder comprises an orientation
marker for visually indicating the axial orientation of
said distal end of said shaft.

134. A system according to claim 118 wherein said
depth markers disposed on said drill sleeve are
progressively larger from a proximal location to a
distal location thereon, and further wherein said depth
markers disposed on said transverse tunnel drill are
progressively larger from a first location adjacent to
said distal end thereof to a second location adjacent
to a said proximal end thereof.

135. A system according to claim 118 wherein a portion of said distal end of said outrigger provides a first reference point corresponding to said depth markers of said drill sleeve.

5

136. A system according to claim 118 wherein a portion of said drill sleeve provides a second reference point corresponding to said depth markers of said transverse drill.

10

137. A method for securing a graft ligament in a bone tunnel, comprising the steps of:

looping a graft ligament through a graft hole in a graft ligament support block;

15

advancing the graft ligament support block into the bone tunnel;

20

positioning a drill guide in attachment to the graft support block, the drill guide comprising an outrigger and a drill sleeve movably attached to the outrigger, and the drill sleeve having depth markers thereon;

determining a proper transverse tunnel depth with the drill sleeve and the outrigger by moving the drill sleeve within the outrigger toward the bone tunnel and reading the depth markers on the drill sleeve;

5 forming a transverse tunnel in the host bone to a proper transverse tunnel depth by drilling a transverse tunnel drill to a given depth according to markers disposed on thereon, with the transverse tunnel being aligned with a transverse fixation pin hole in the
10 graft ligament support block; and

pinning the graft ligament support block within the bone tunnel by advancing a transverse fixation pin along the transverse tunnel in the host bone and into the transverse fixation pin hole in the graft ligament
15 support block.

138. A method according to claim 137 wherein an installation tool is used to advance the graft ligament support block into the bone tunnel.

20

139. A method according to claim 137 wherein the two free ends of the graft ligament are secured to the

installation tool prior to advancing the graft ligament support block into the bone tunnel.

5 140. A method according to claim 137 wherein the installation tool is used to form the transverse tunnel in the host bone.

10 141. A method according to claim 137 wherein a tow suture is used to advance the graft ligament support block into the bone tunnel.

142. A method for securing a graft ligament in a bone tunnel, said method comprising the steps of:

15 positioning a drill guide in attachment to a reamer inserted into the bone tunnel, the drill guide comprising an outrigger and a drill sleeve movably attached to the outrigger, and the drill sleeve having depth markers thereon;

20 determining a proper transverse tunnel depth with the drill sleeve and the outrigger by moving the drill sleeve within the outrigger toward the bone tunnel and reading the depth markers on the drill sleeve;

forming a transverse tunnel in the host bone to a proper transverse tunnel depth by drilling a transverse tunnel drill to a given depth according to markers disposed thereon;

5 removing the reamer from the bone tunnel;

looping a graft ligament through a graft hole in a graft ligament support block;

10 advancing the graft ligament support block into the bone tunnel so that a transverse fixation pin hole in the graft ligament support block is aligned with the transverse tunnel; and

15 pinning the graft ligament support block within the bone tunnel by advancing a transverse fixation pin along the transverse tunnel in the host bone and into the transverse fixation pin hole in the graft ligament support block.

20 143. A method according to claim 142 wherein an installation tool is used to advance the graft ligament support block into the bone tunnel.

144. A method according to claim 142 wherein the two free ends of the graft ligament are secured to the installation tool prior to advancing the graft ligament support block into the bone tunnel.

5

145. A system for use in reconstructing a ligament, said system comprising:

a graft ligament support block for supporting a graft ligament in a bone tunnel, said graft ligament support block comprising:

10

a body having a distal end, a proximal end, a longitudinal axis extending between said distal end and said proximal end, and at least one element for engagement by an installation tool;

15

a graft hole extending through said body transverse to said longitudinal axis and configured to receive a graft ligament therein; and

20

a transverse fixation pin hole extending through said body transverse to said longitudinal axis and configured to receive a transverse fixation pin therein;

an installation tool comprising:

a holder, said holder comprising:

a shaft having a distal end, a proximal end, and longitudinal axis extending between said distal end and said proximal end, said proximal end of said shaft configured to engage said at least one element of said body;

a handle mounted to said proximal end of said shaft;

a drill guide adapted to be releasably secured to said holder, said drill guide comprising:

an outrigger comprising a distal end and a proximal end, said proximal end of said outrigger configured to be releasably secured to said holder; and

a drill sleeve moveably attached to said distal end of said outrigger, and said drill sleeve comprising a drilling lumen extending therethrough; and

a transverse tunnel drill having a distal end and a proximal end, said distal end of said transverse tunnel drill configured for placement through said drill sleeve so as to drill a transverse bone tunnel through the bone tunnel, said transverse tunnel drill having a stop element configured to engage said drill

sleeve so as to limit drilling to a predetermined depth.

5 146. A system according to claim 145 wherein said stop element is adjustably disposed between said distal end and said proximal end of said transverse tunnel drill so as to allow adjustment of said predetermined depth of drilling for the transverse bone tunnel.

10 147. A system according to claim 146 wherein said stop element comprises a collar slideably disposed on said transverse tunnel drill and a locking set screw carried by said collar for selectively engaging said transverse tunnel drill so as to allow adjustment of
15 said predetermined depth of drilling for the transverse bone tunnel.

20 148. A system according to claim 145 wherein said stop element comprises a collar fixedly disposed on said transverse tunnel drill at a given distance from said distal end thereof so as to limit drilling of said transverse tunnel drill to said predetermined depth.

149. A system for use in reconstructing a ligament, said system comprising:

5 a graft ligament support block for supporting a graft ligament in a bone tunnel, said graft ligament support block comprising:

a body having a distal end, a proximal end, and a longitudinal axis extending between said distal end and said proximal end; and

10 a graft hole extending through said body transverse to said longitudinal axis and configured to receive a graft ligament therein;

15 a stepped transverse fixation pin having a distal end, a proximal end, a longitudinal axis extending between said distal end and said proximal end, a first portion at said distal end, a second portion at said proximal end, said first portion having a smaller diameter than second portion, and an annular shoulder configured between said first portion and said second portion, wherein said first portion, said second portion and said annular shoulder form a given profile

20

in a cross-section of a given plane perpendicular to the longitudinal axis;

a stepped transverse tunnel drill having a distal end, a proximal end and a longitudinal axis extending between said distal end and said proximal end, said stepped transverse drill corresponding to said given profile of said stepped transverse fixation pin so as to provide a stepped transverse tunnel through the bone tunnel configured to receive said given profile of said stepped transverse fixation pin; and

a depth gauge having a distal end and a proximal end, said distal end of said depth gauge configured for placement through a drill sleeve to engage a portion of said stepped transverse tunnel corresponding to said annular shoulder of said stepped fixation pin, and said depth gauge having markings thereon between said distal end and said proximal end so as to indicate said transverse fixation pin hole depth between said portion corresponding to said annular shoulder of the stepped fixation pin and a bone surface.

150. A system according to claim 149 wherein said markings of said depth gauge indicate said transverse fixation pin hole depth at proximal end of said drill sleeve.

5

151. A system according to claim 149 further comprising a transverse fixation pin inserter having a proximal end and a distal end, depth markings disposed thereon between said proximal end and said distal end, and an engagement surface at said distal end to position said transverse fixation pin into said transverse fixation pin hole.

10

152. A system according to claim 151 wherein said depth markings of said transverse fixation pin inserter indicate depth of said transverse fixation pin at a proximal end of said drill sleeve.

15

153. A method for securing a graft ligament in a bone tunnel, comprising the steps of:

20

looping a graft ligament through a graft hole in a graft ligament support block;

- 132 -

advancing the graft ligament support block into
the bone tunnel;

determining a proper transverse tunnel depth by
reading a position of a first set of depth markers on a
5 drill sleeve relative to an outrigger;

forming a transverse tunnel in the host bone using
a transverse tunnel drill having a second set of depth
markers thereon so as to drill said transverse tunnel
to said proper transverse tunnel depth, with a
10 transverse tunnel being aligned with a transverse
fixation pin hole in the graft ligament support block;
and

pinning the graft ligament support block within
the bone tunnel by selecting a transverse fixation pin
.5 based on the proper transverse tunnel depth determined
by the first set of depth markers on the drill sleeve
and advancing the selected transverse fixation pin
along the transverse tunnel in the host bone and into
the transverse fixation pin hole in the graft ligament
20 support block.

- 133 -

154. A method for securing a graft ligament in a bone tunnel, said method comprising the steps of:

determining a proper transverse tunnel depth by reading a position of a first set of depth markers on a drill sleeve relative to an outrigger;

forming a transverse tunnel in the host bone using a transverse tunnel drill having a second set of depth markers thereon so as to drill said transverse tunnel to said proper transverse tunnel depth;

looping a graft ligament through a graft hole in a graft ligament support block;

advancing the graft ligament support block into the bone tunnel so that a transverse fixation pin hole in the graft ligament support block is aligned with the transverse tunnel; and

pinning the graft ligament support block within the bone tunnel by selecting a transverse fixation pin based on the proper transverse tunnel depth determined by the first set of depth markers on the drill sleeve and advancing a transverse fixation pin along the transverse tunnel in the host bone and into the

transverse fixation pin hole in the graft ligament support block.

155. A method for securing a graft ligament in a bone tunnel, comprising the steps of:

looping a graft ligament through a graft hole in a graft ligament support block;

advancing the graft ligament support block into the bone tunnel;

forming a transverse tunnel in the host bone to a predetermined depth using a transverse tunnel drill having a stop element at a predetermined distance from a distal end of said transverse tunnel drill, said stop element configured to engage a drill sleeve so as to limit drilling to said predetermined depth, with said transverse tunnel being aligned with a transverse fixation pin hole in the graft ligament support block; and

pinning the graft ligament support block within the bone tunnel by advancing a transverse fixation pin along the transverse tunnel in the host bone and into

the transverse fixation pin hole in the graft ligament support block.

156. A method for securing a graft ligament in a
5 bone tunnel, said method comprising the steps of:

forming a transverse tunnel in the host bone to a
predetermined depth using a transverse tunnel drill
having a stop element at a predetermined distance from
a distal end of said transverse tunnel drill, said stop
10 element configured to engage a drill sleeve so as to
limit drilling to said predetermined depth;

looping a graft ligament through a graft hole in a
graft ligament support block;

15 advancing the graft ligament support block into
the bone tunnel so that a transverse fixation pin hole
in the graft ligament support block is aligned with the
transverse tunnel; and

pinning the graft ligament support block within
the bone tunnel by advancing a transverse fixation pin
20 along the transverse tunnel in the host bone and into
the transverse fixation pin hole in the graft ligament
support block.

157. Apparatus for use in reconstructing a ligament, said apparatus comprising:

5 a graft ligament support block for supporting a graft ligament in a bone tunnel, said graft ligament support block comprising:

10 a body having a distal end, a proximal end, and a longitudinal axis extending between said distal end and said proximal end, said proximal end being tapered so as to facilitate withdrawal of said graft ligament support block through the bone tunnel;

a graft hole extending through said body transverse to said longitudinal axis and configured to receive a graft ligament therein; and

15 a region configured for drilling a transverse fixation pin hole through said body transverse to said longitudinal axis as a transverse hole is drilled through the bone tunnel.

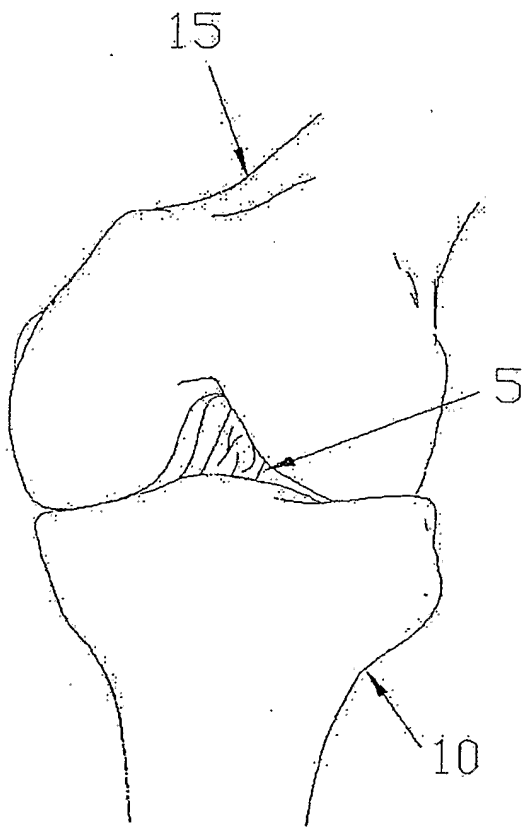

FIG. 1

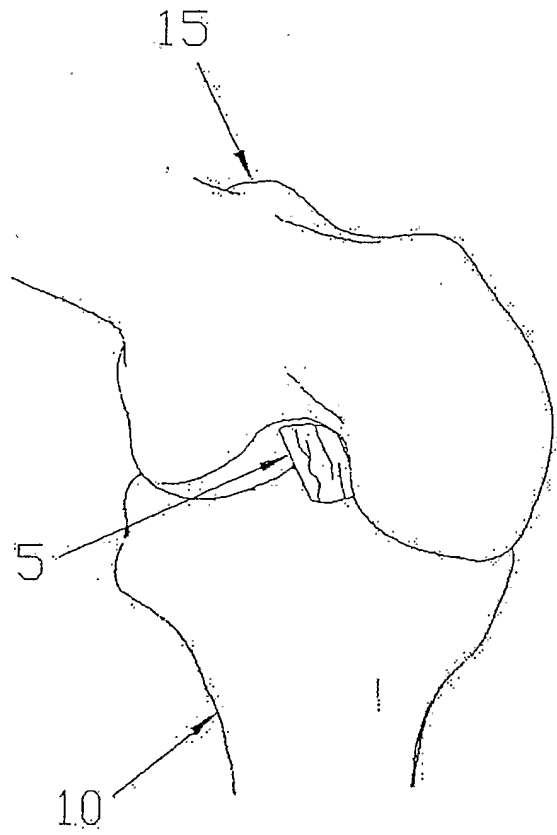

FIG. 2

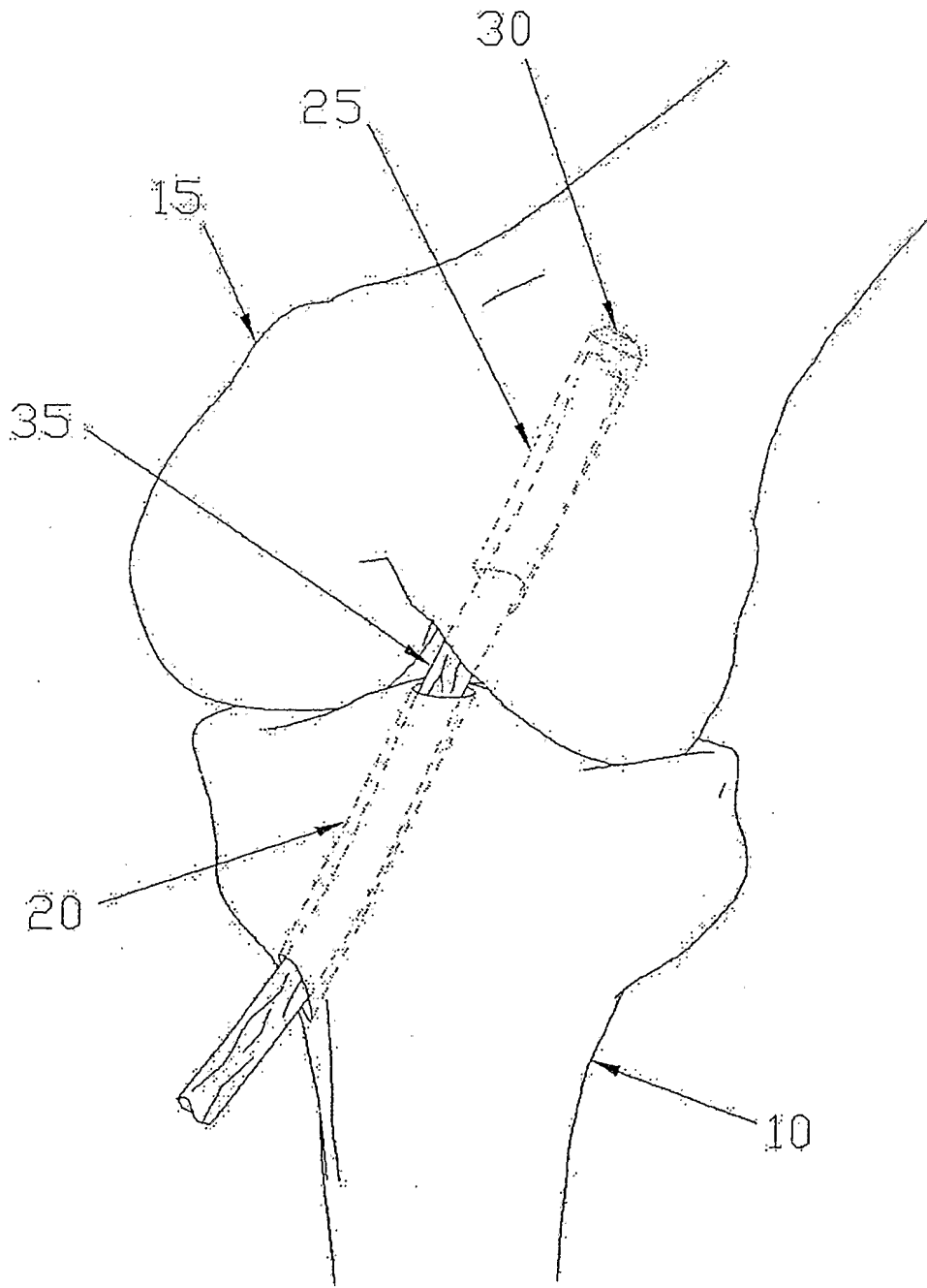

FIG. 3

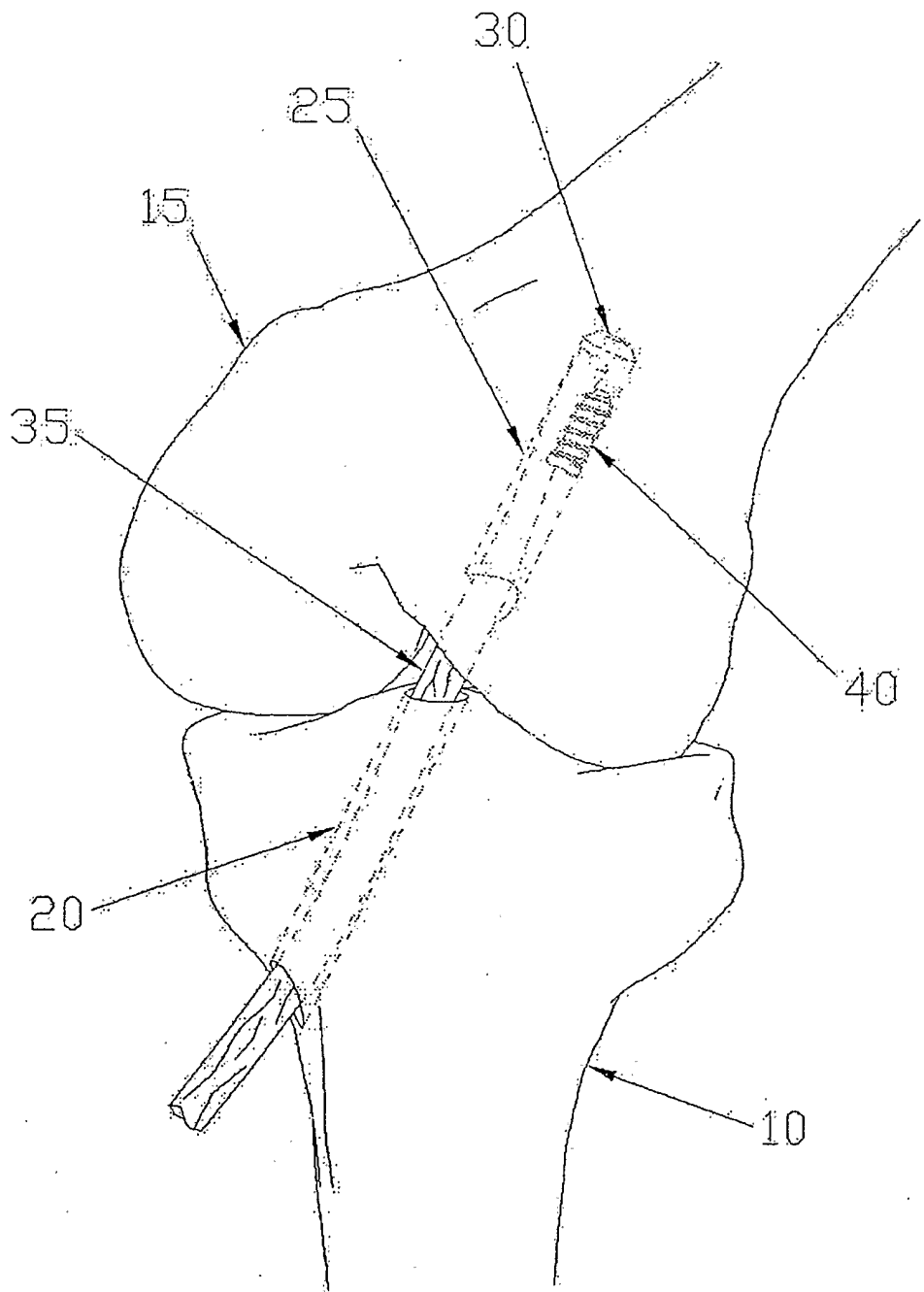

FIG. 4

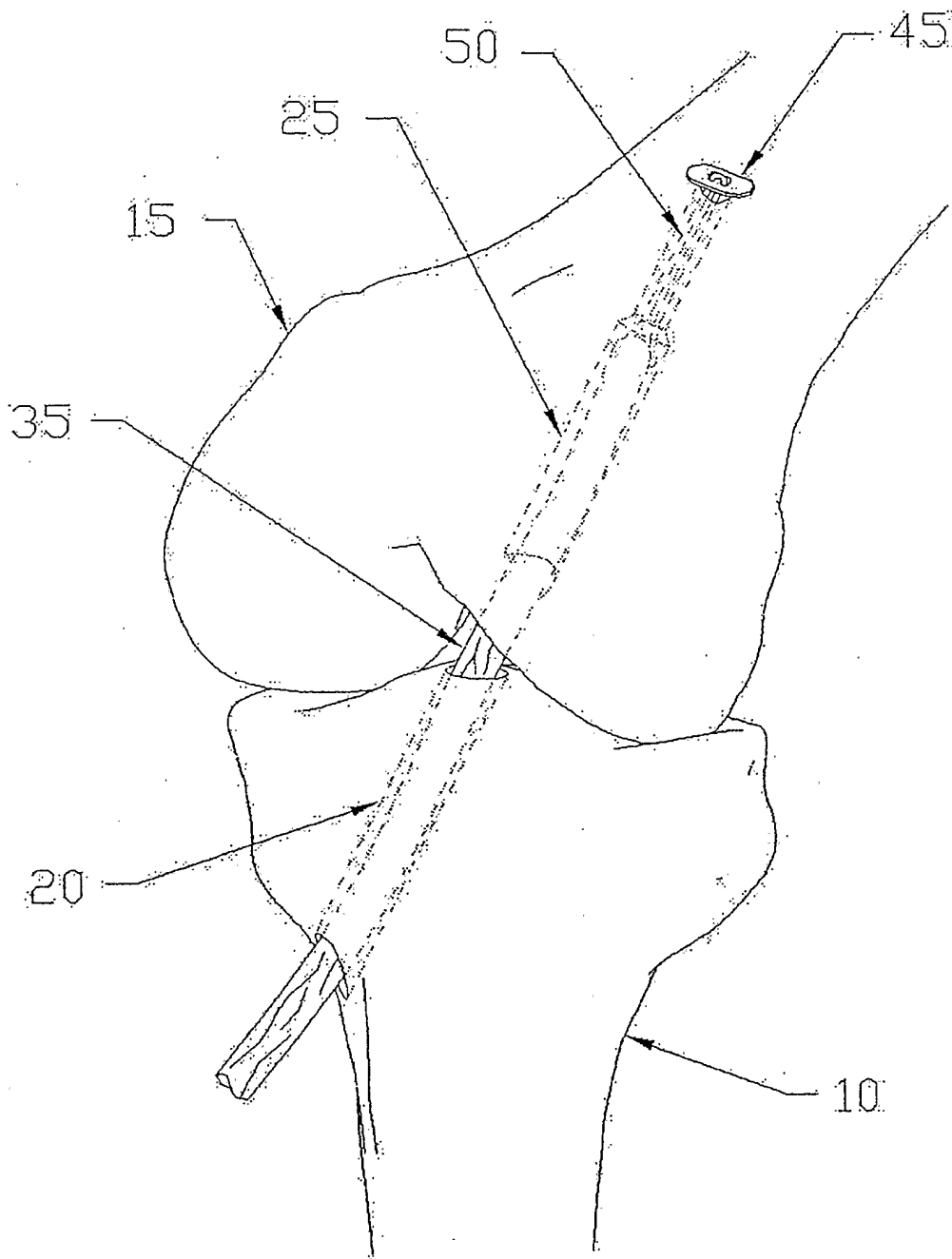

FIG. 5

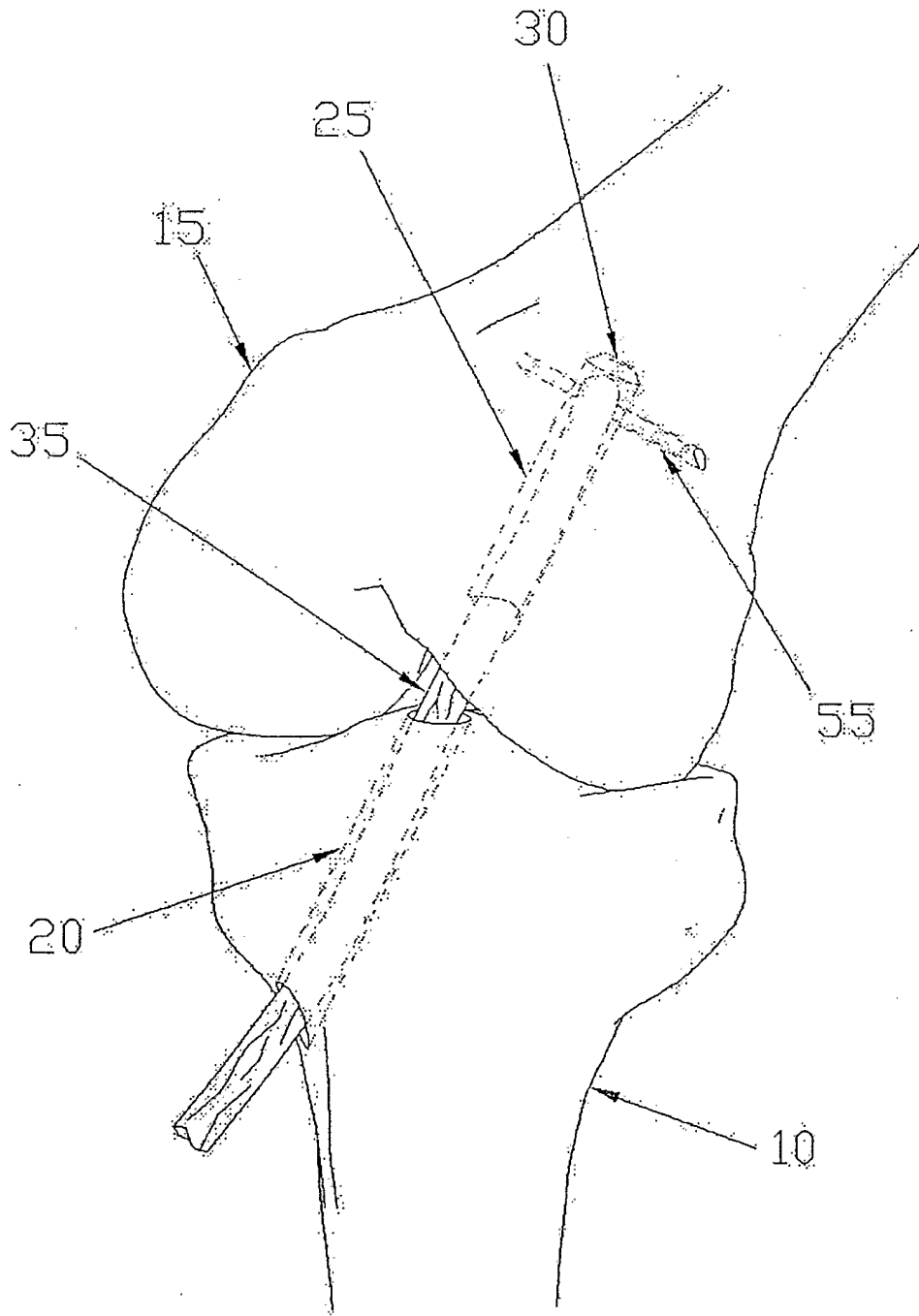

FIG. 6

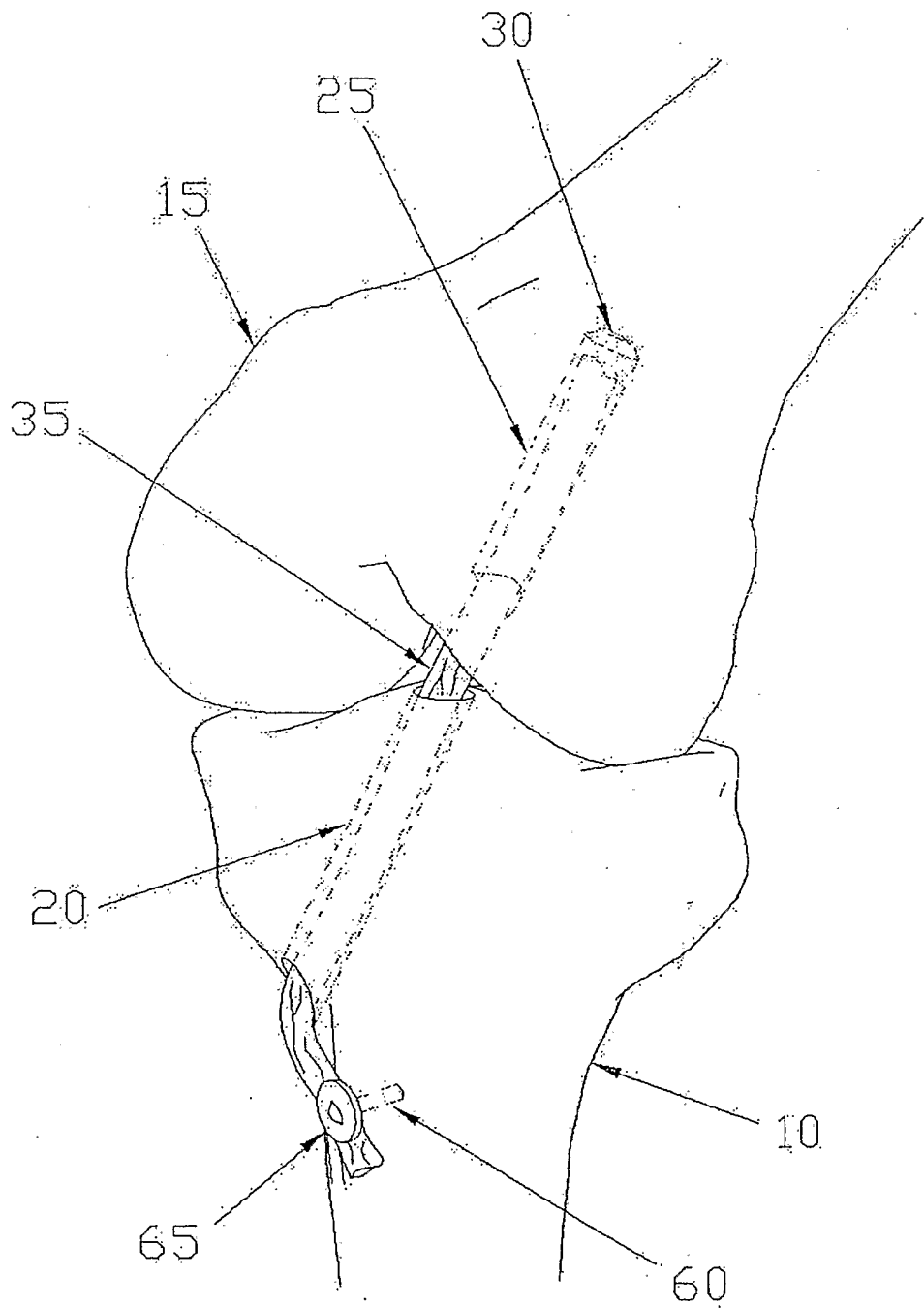

FIG. 7

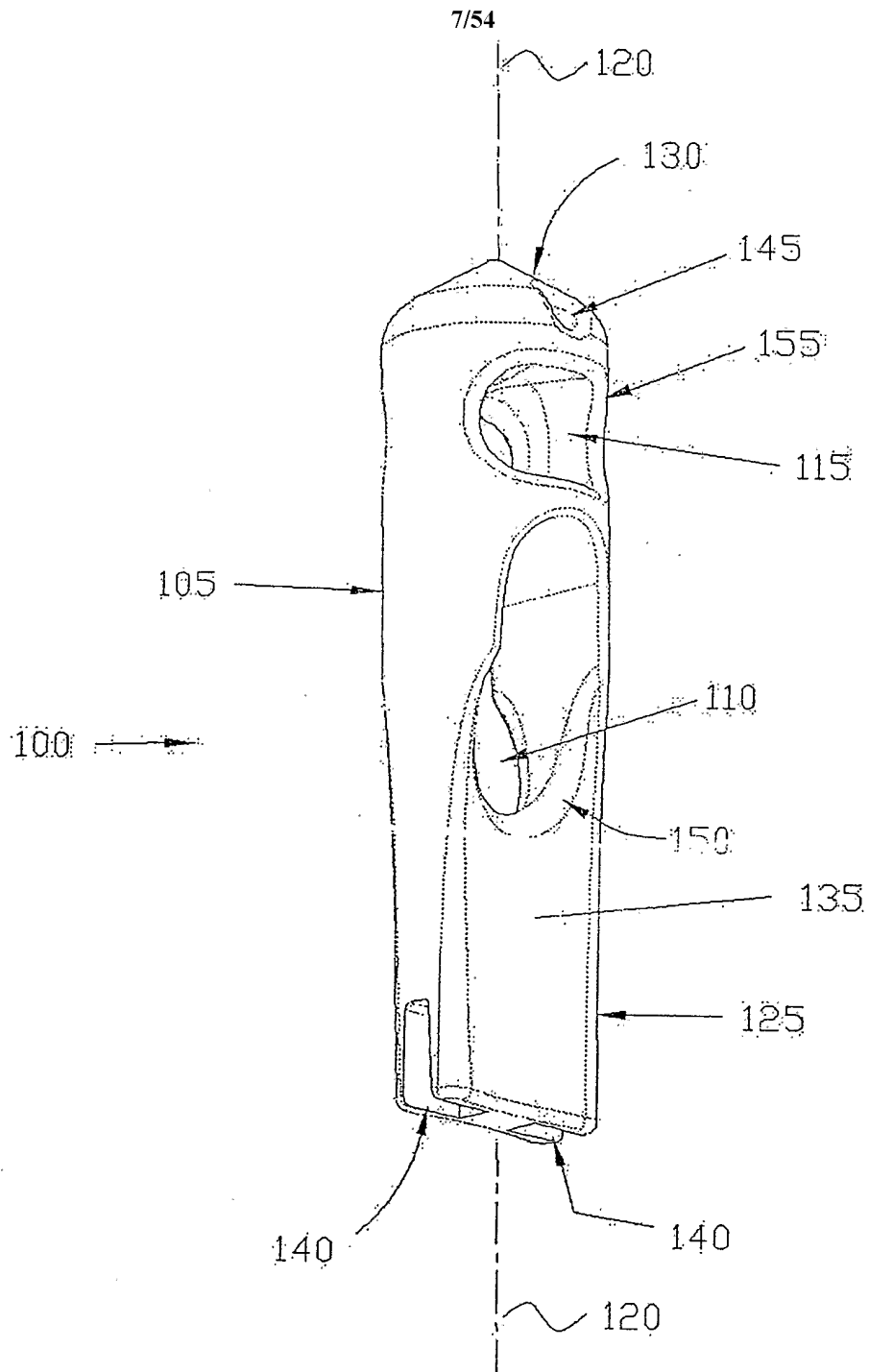

FIG. 8

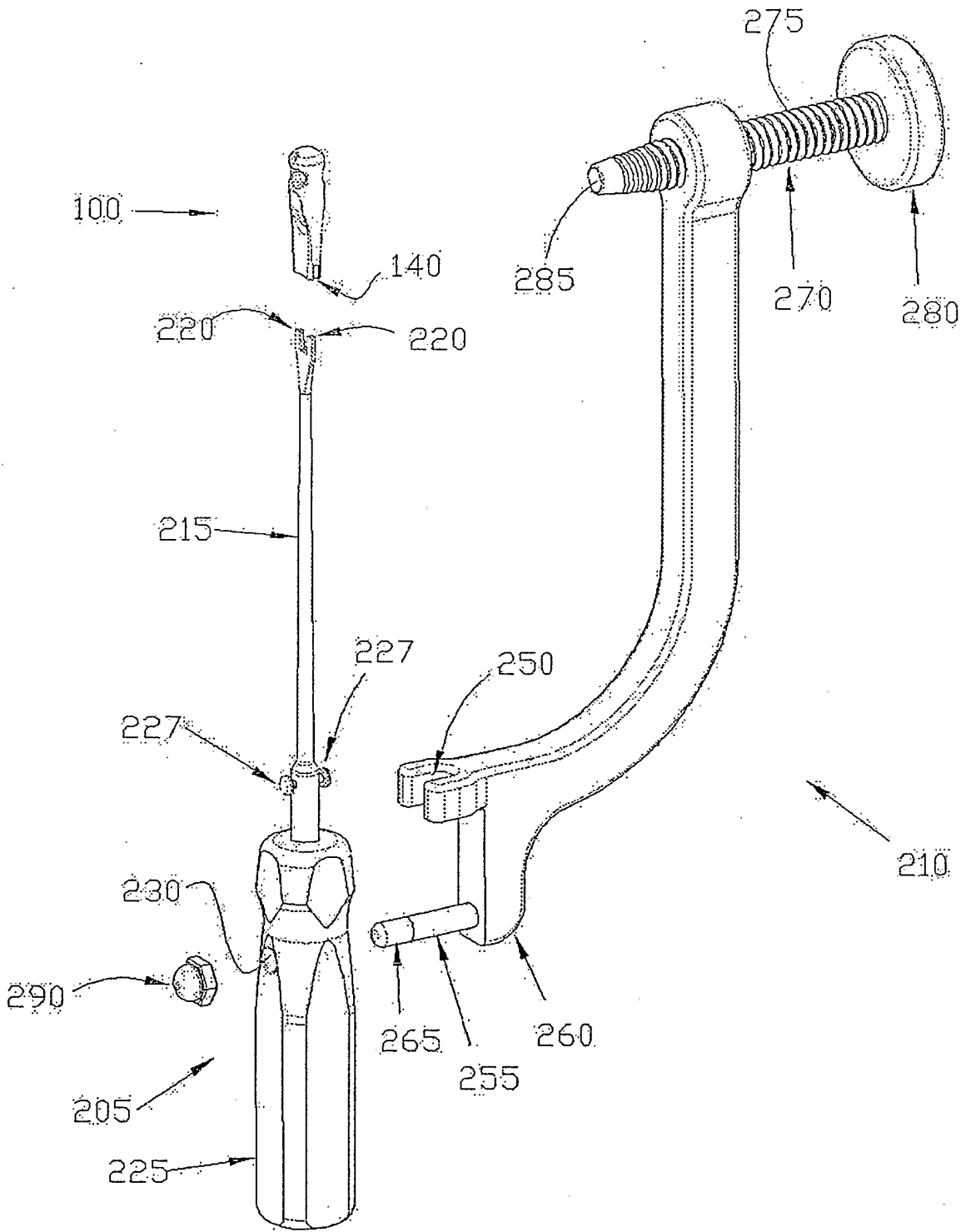

FIG. 9

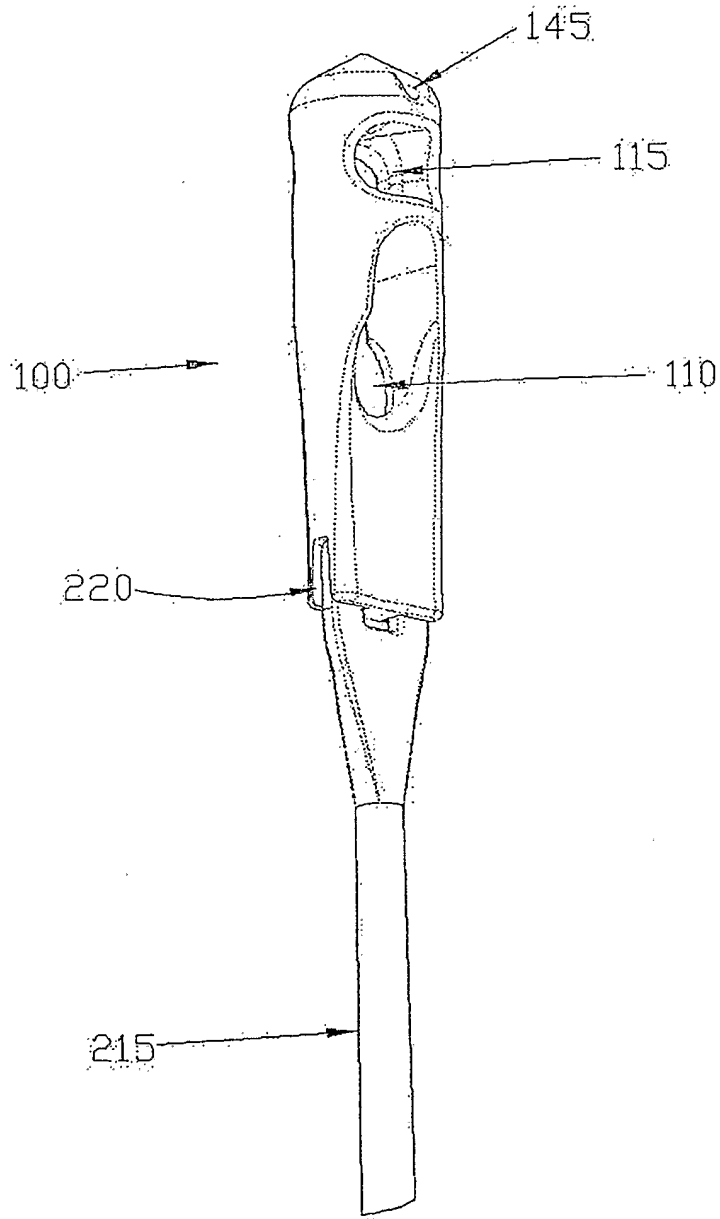

FIG. 10

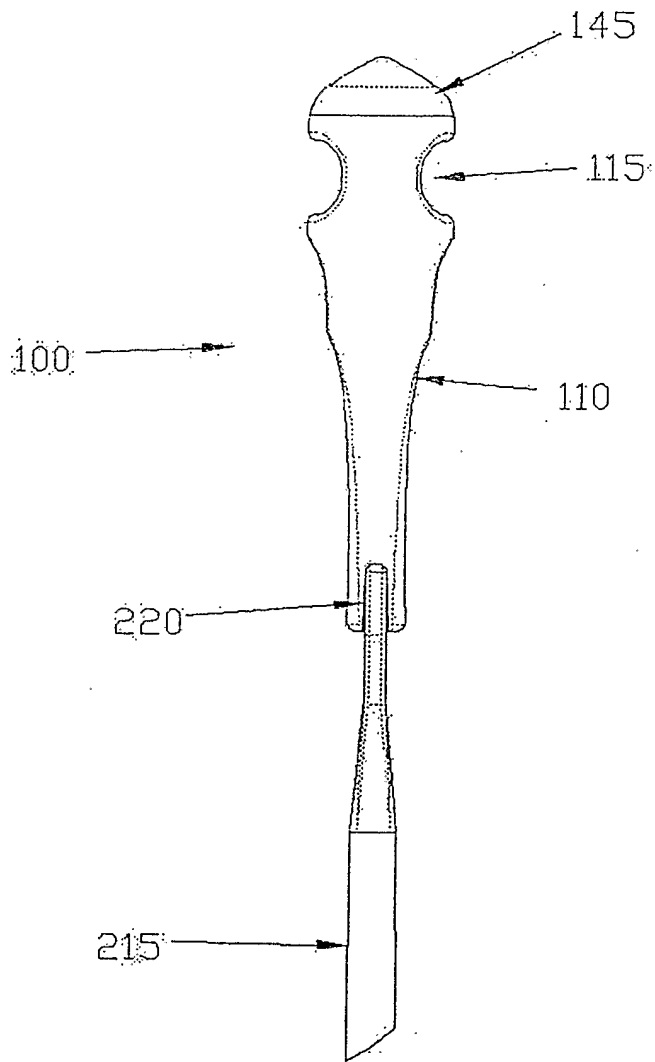

FIG. 11

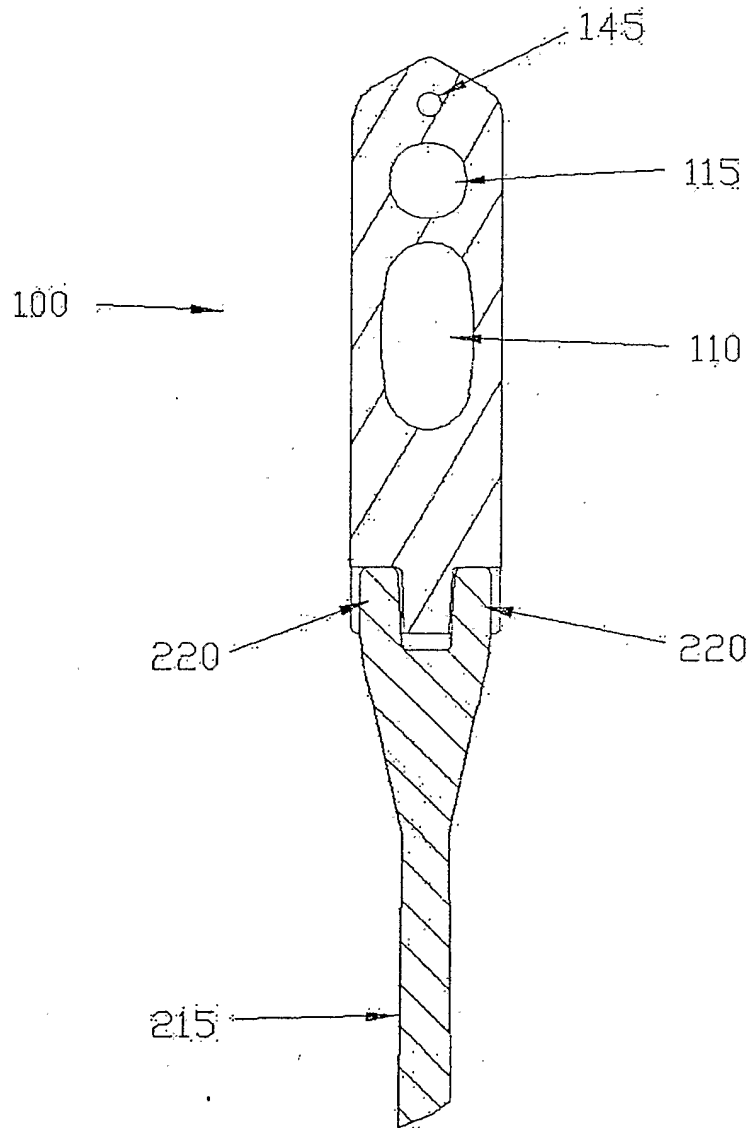

FIG. 12

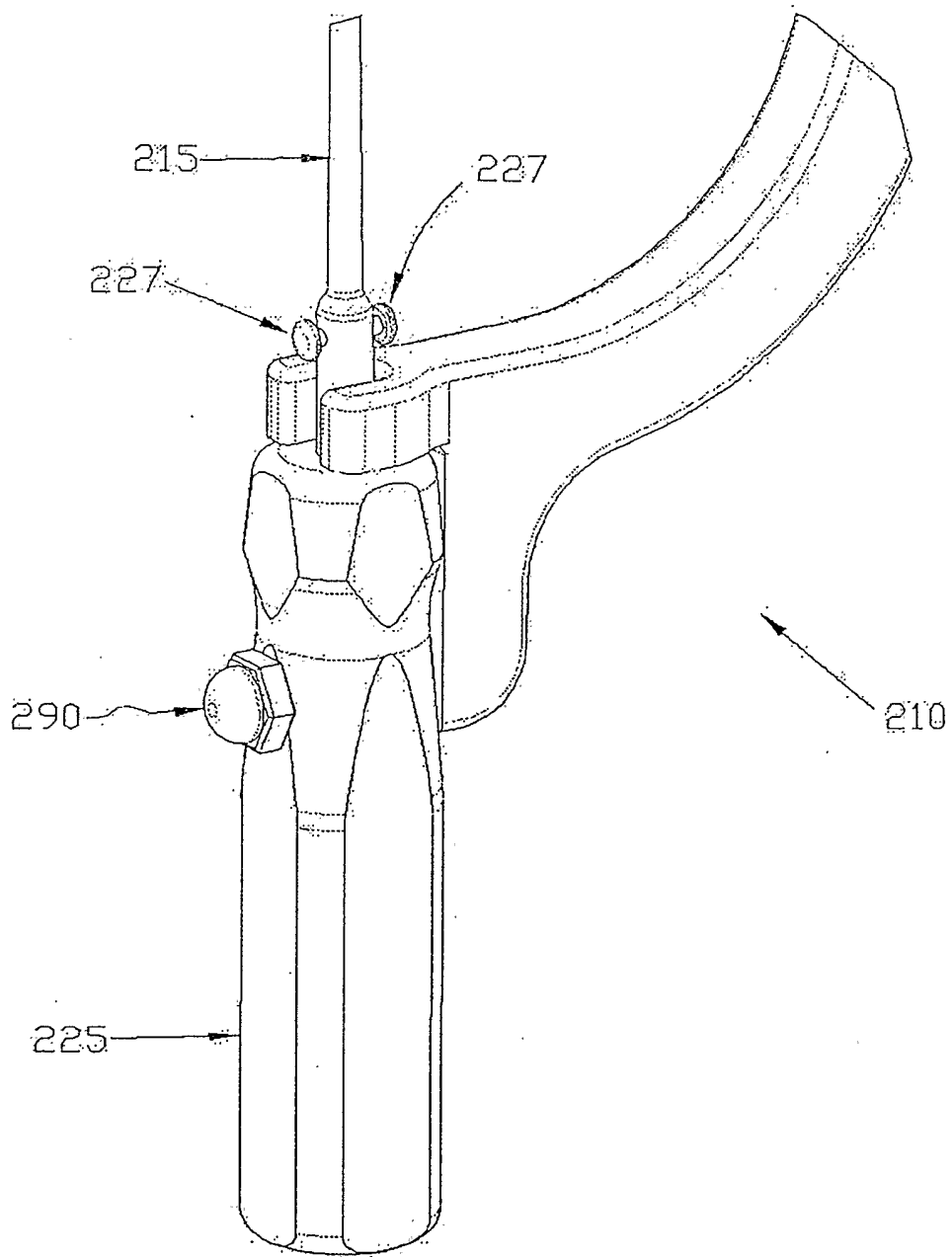

FIG. 13

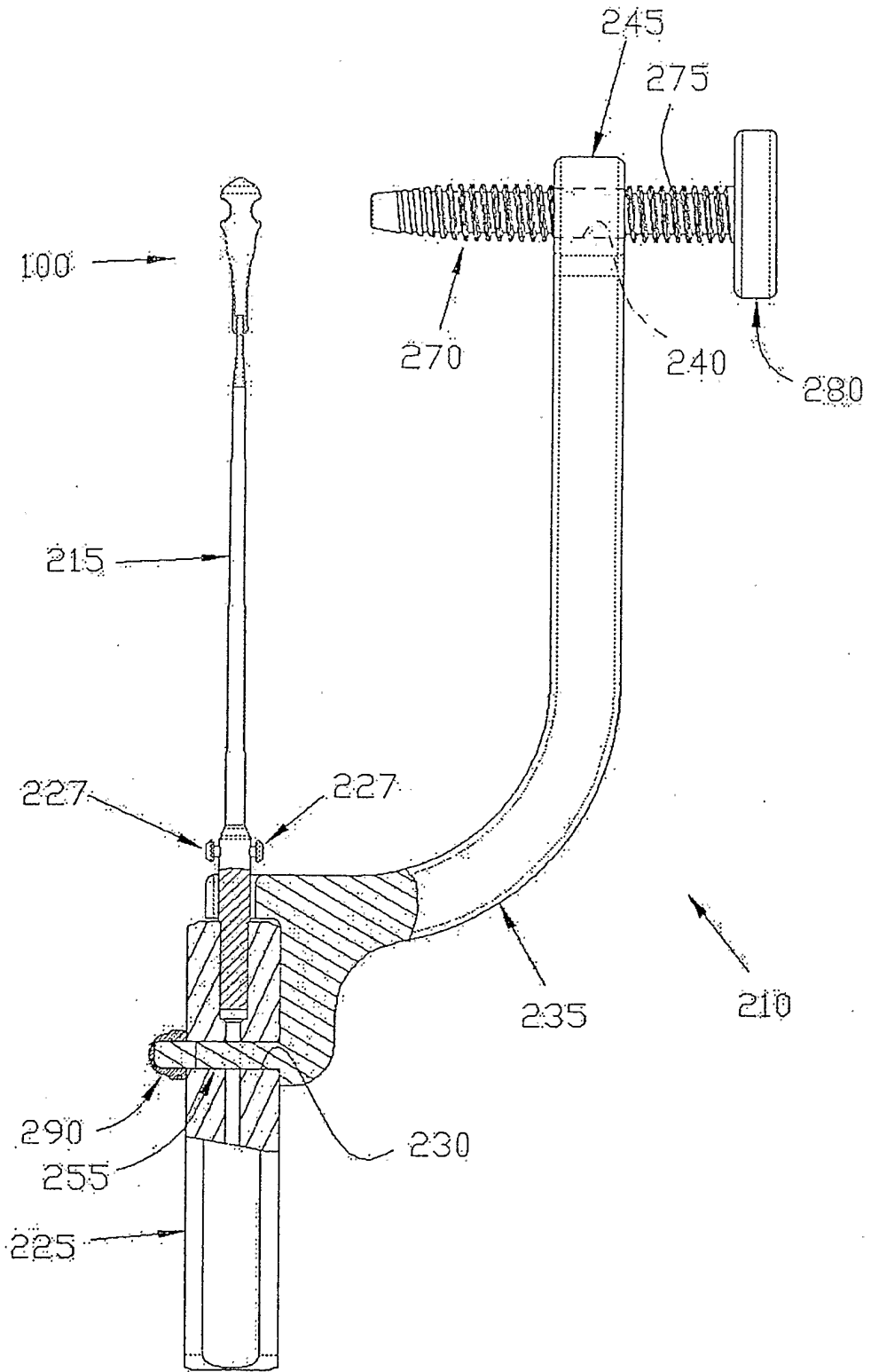

FIG. 14

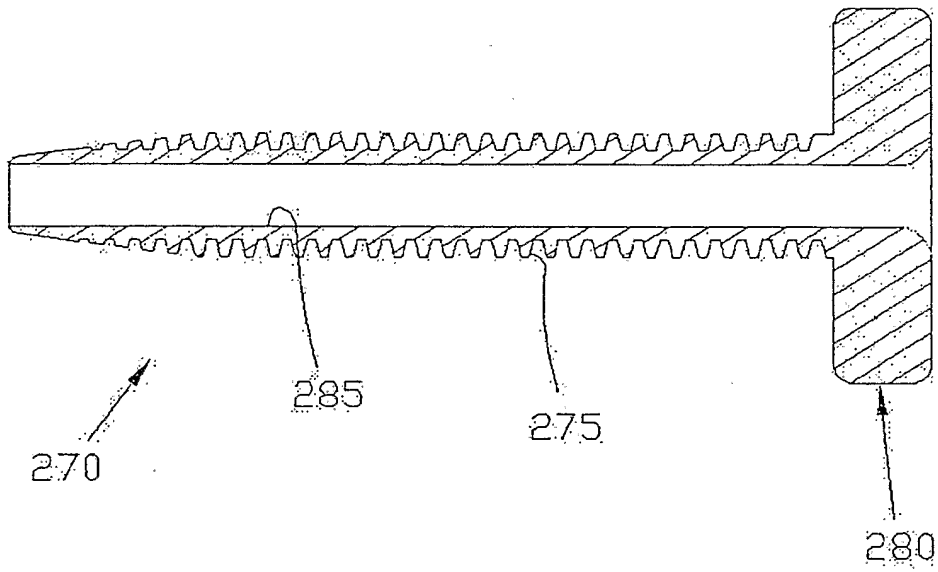

FIG. 15

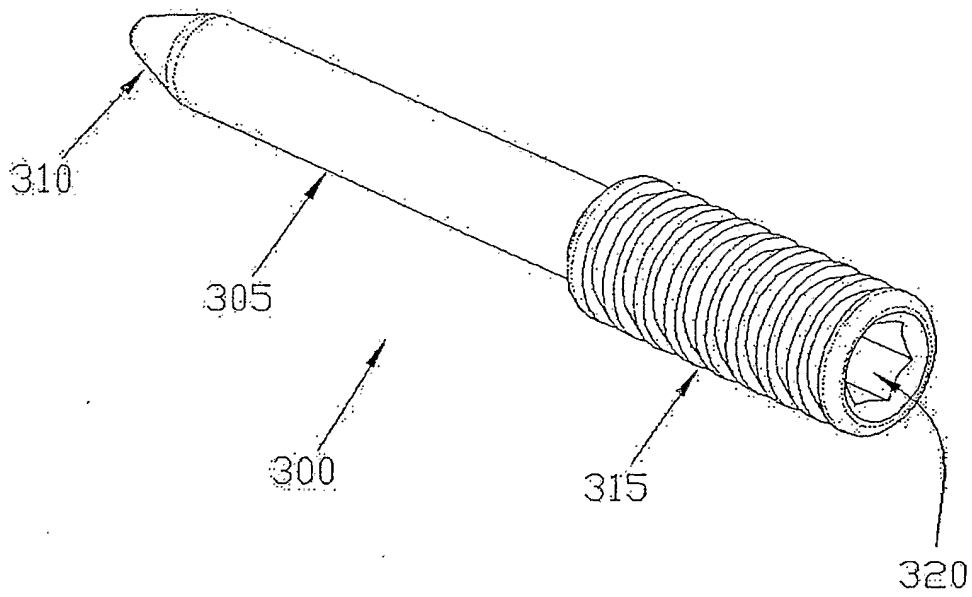

FIG. 16

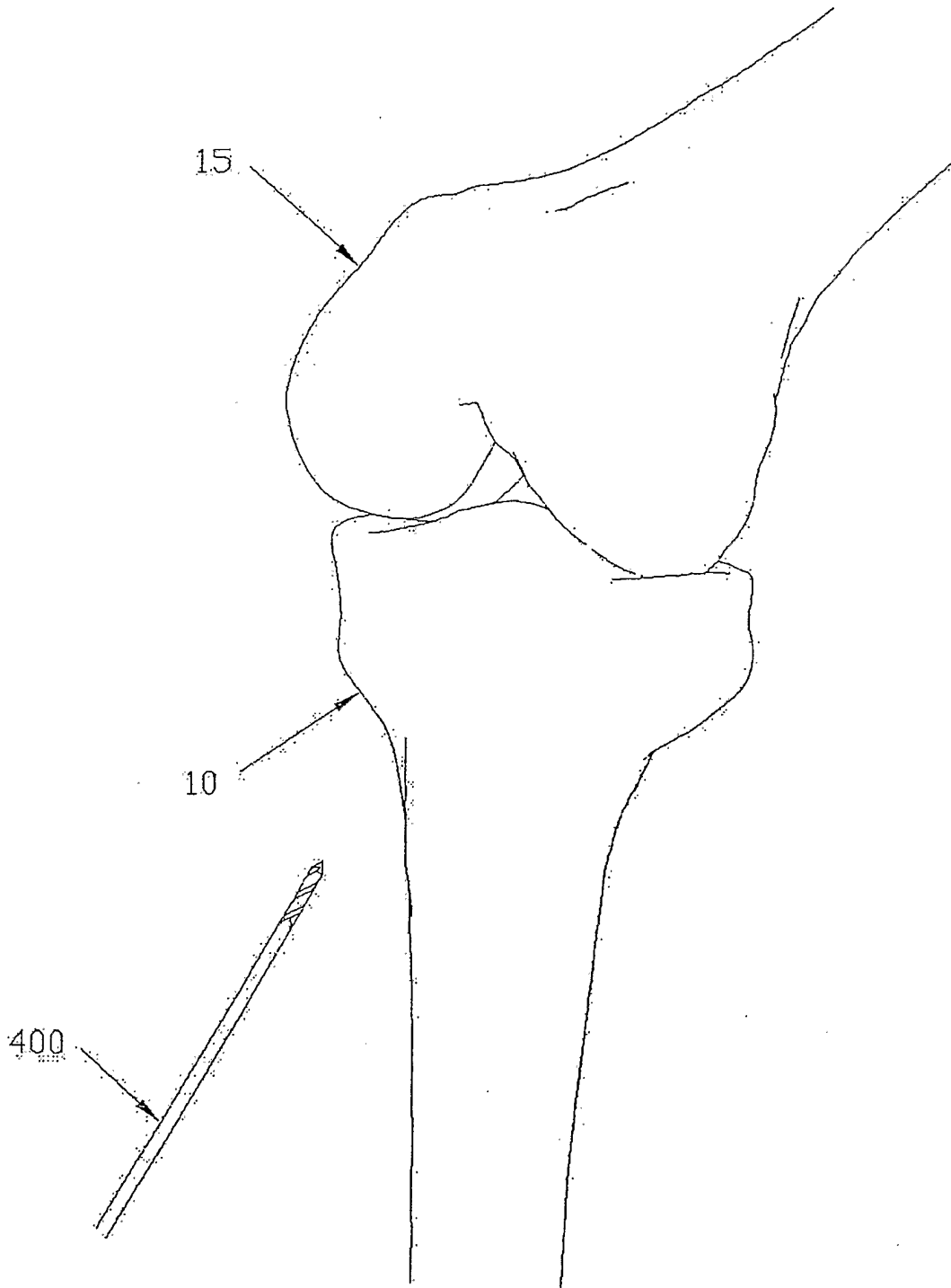

FIG. 17

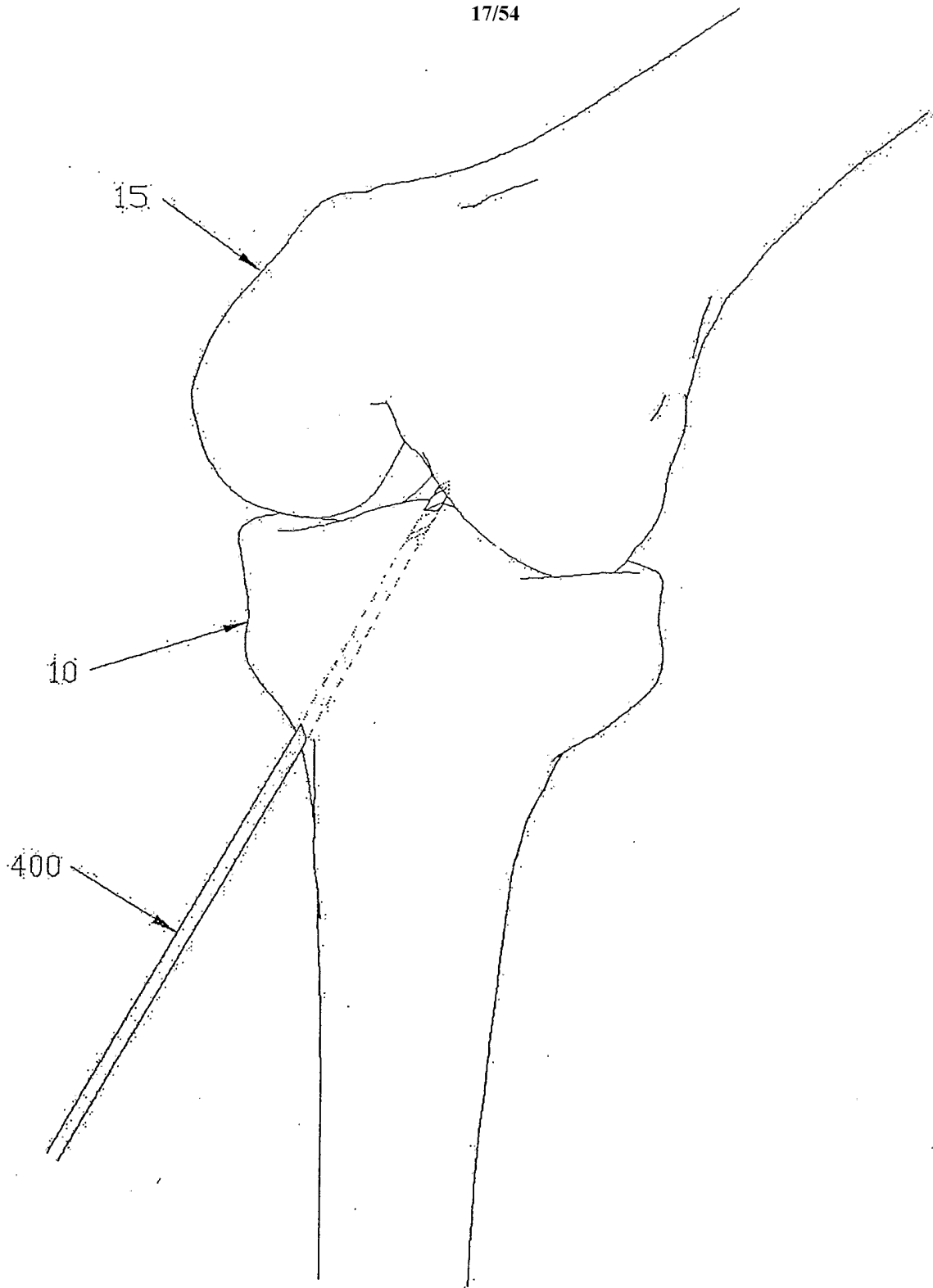

FIG. 18

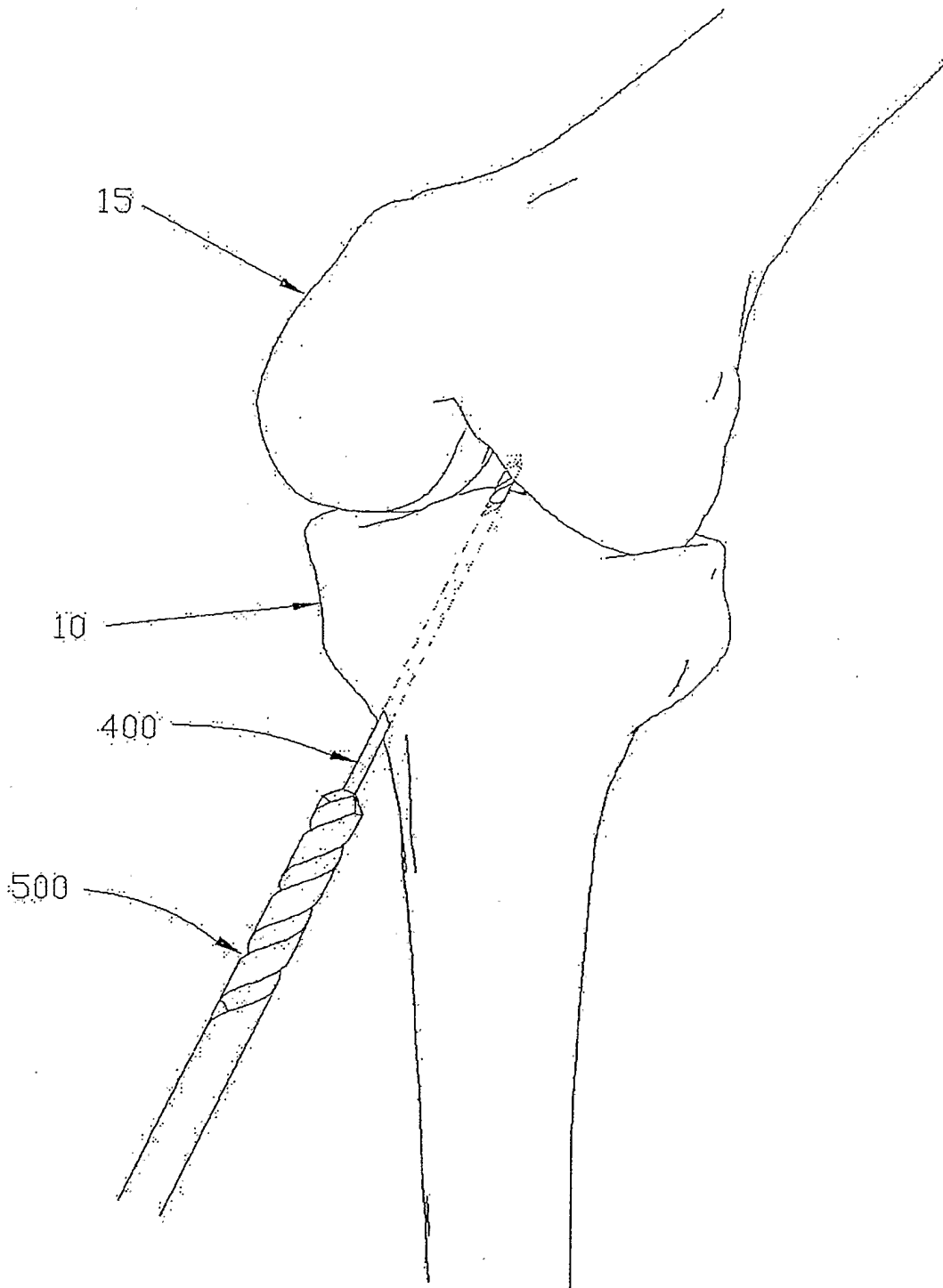

FIG. 19

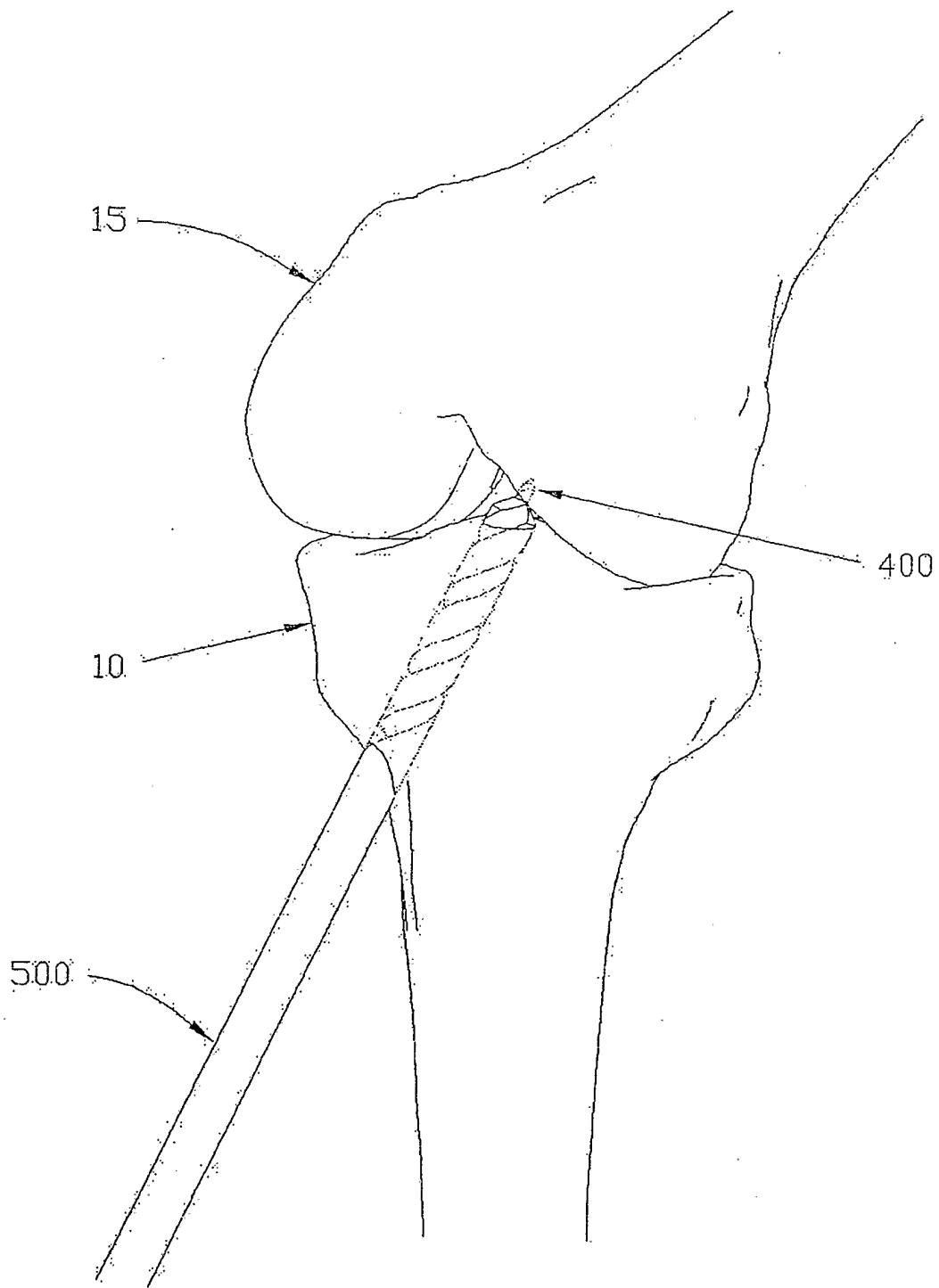

FIG. 20

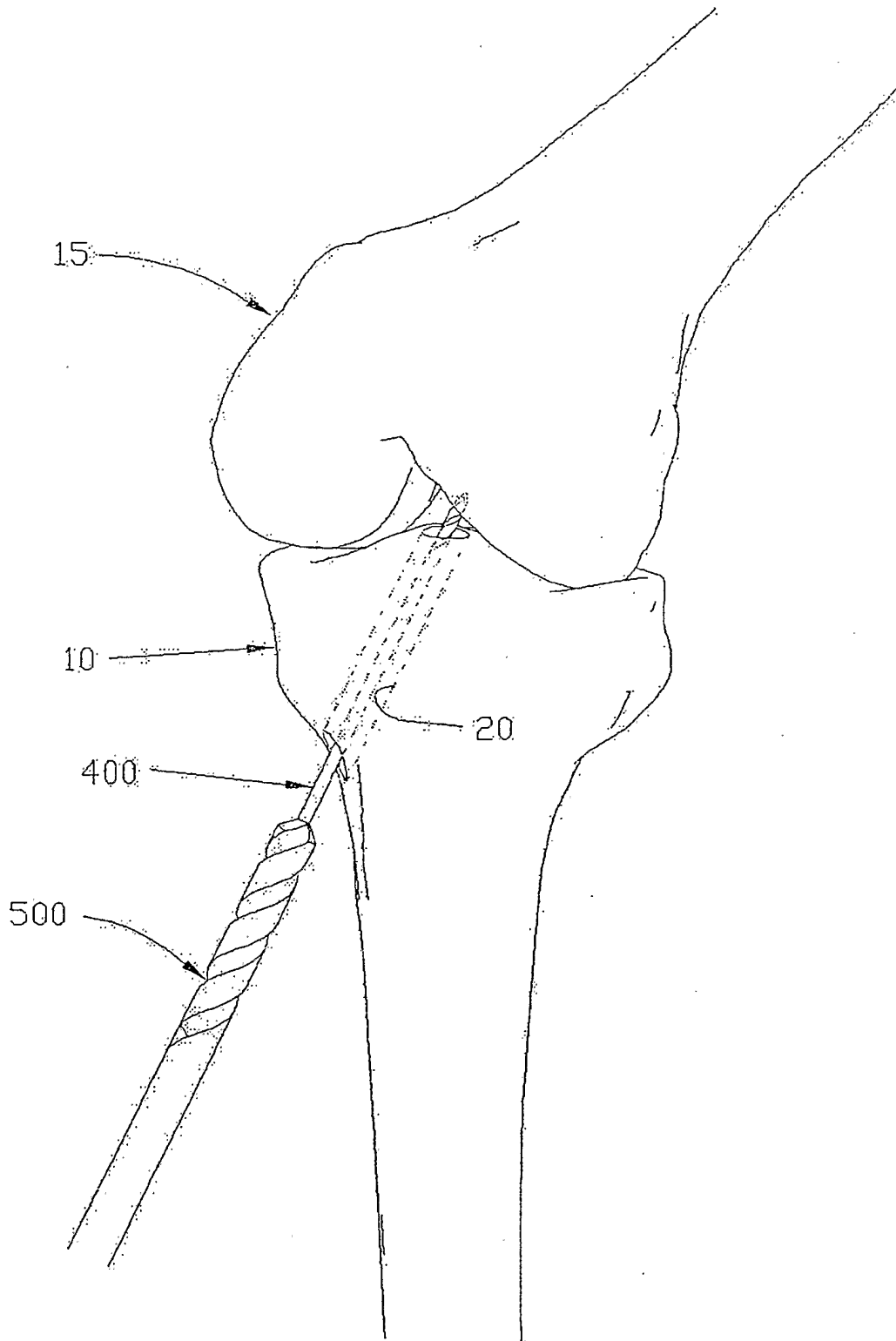

FIG. 21

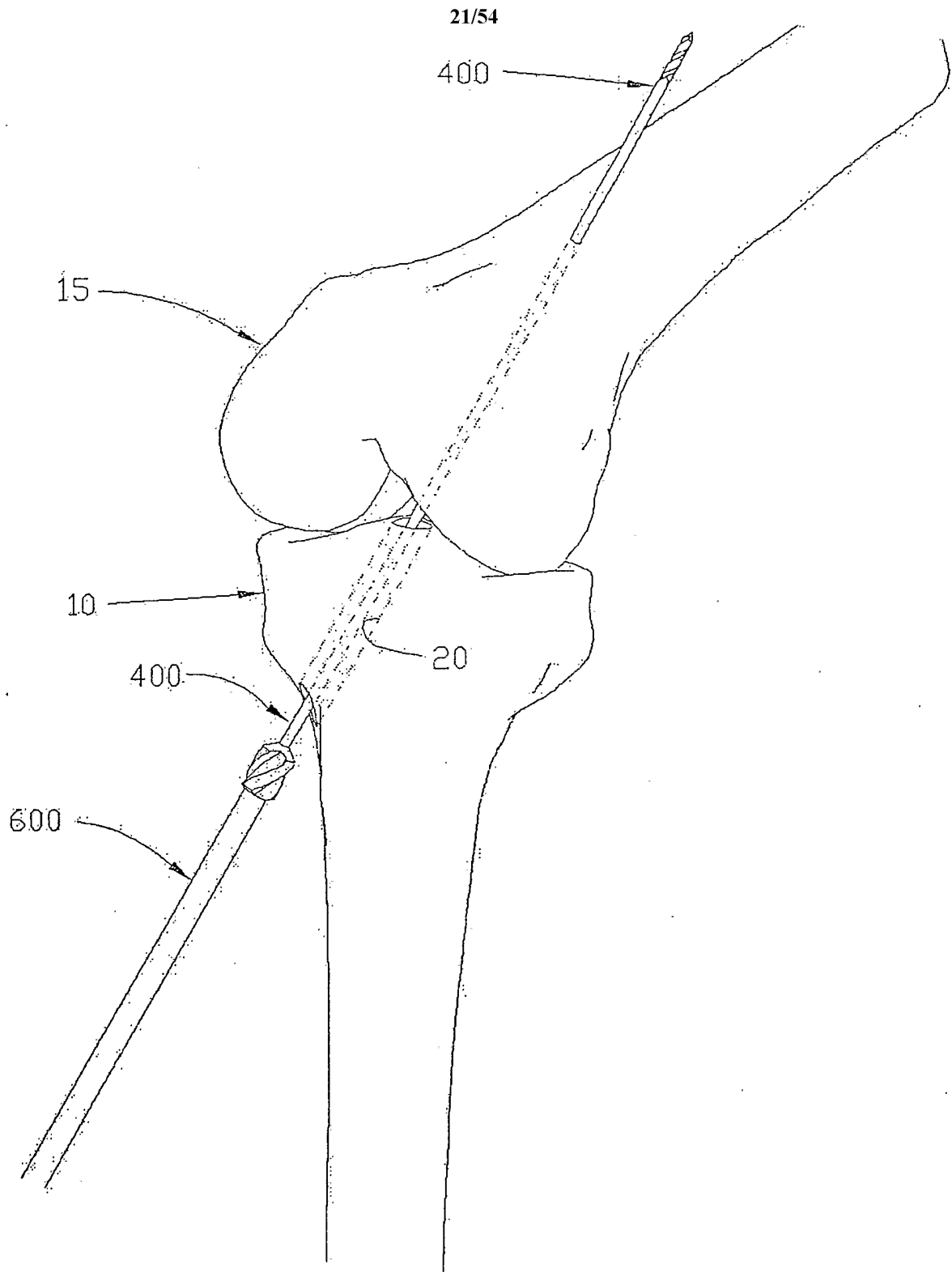

FIG. 22

22/54

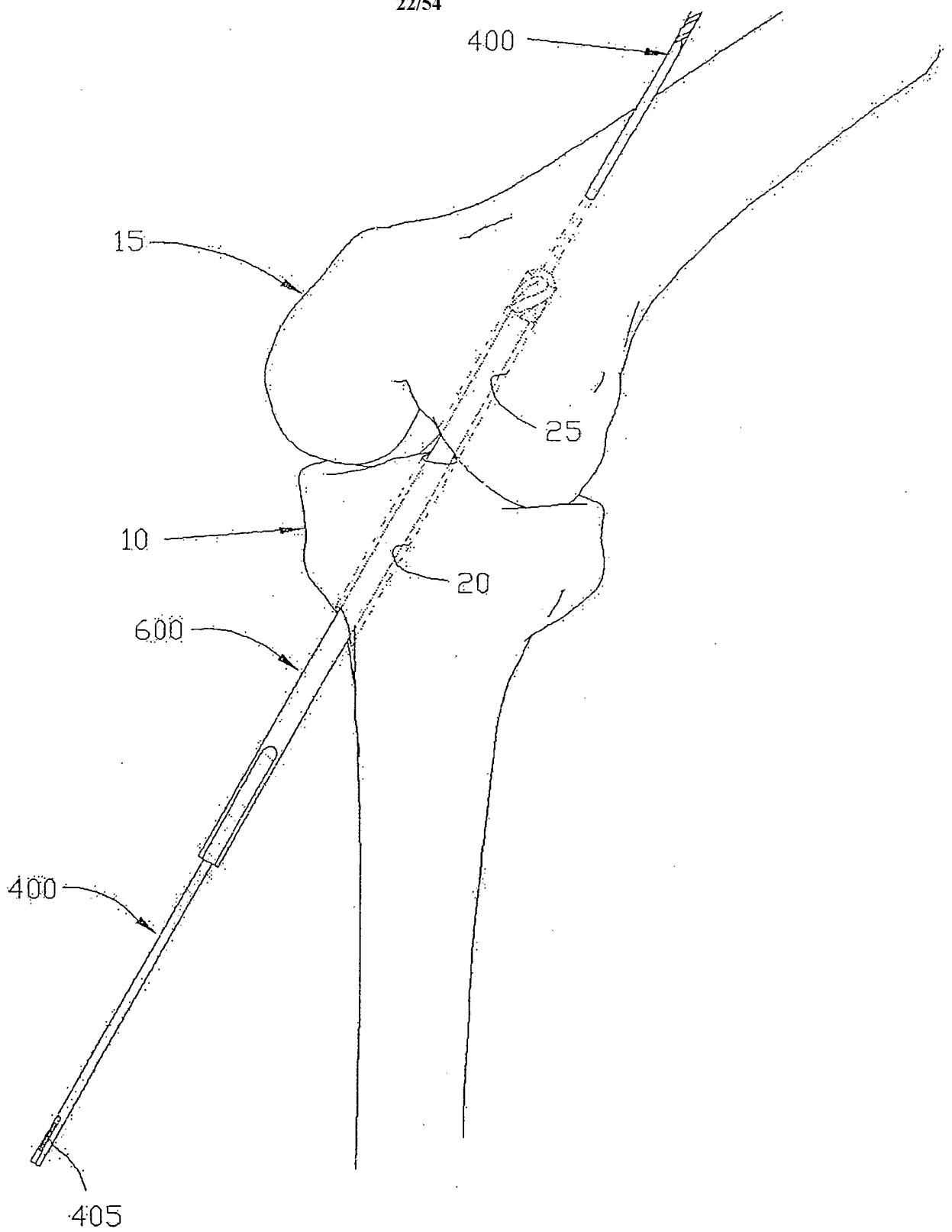

FIG. 23

23/54

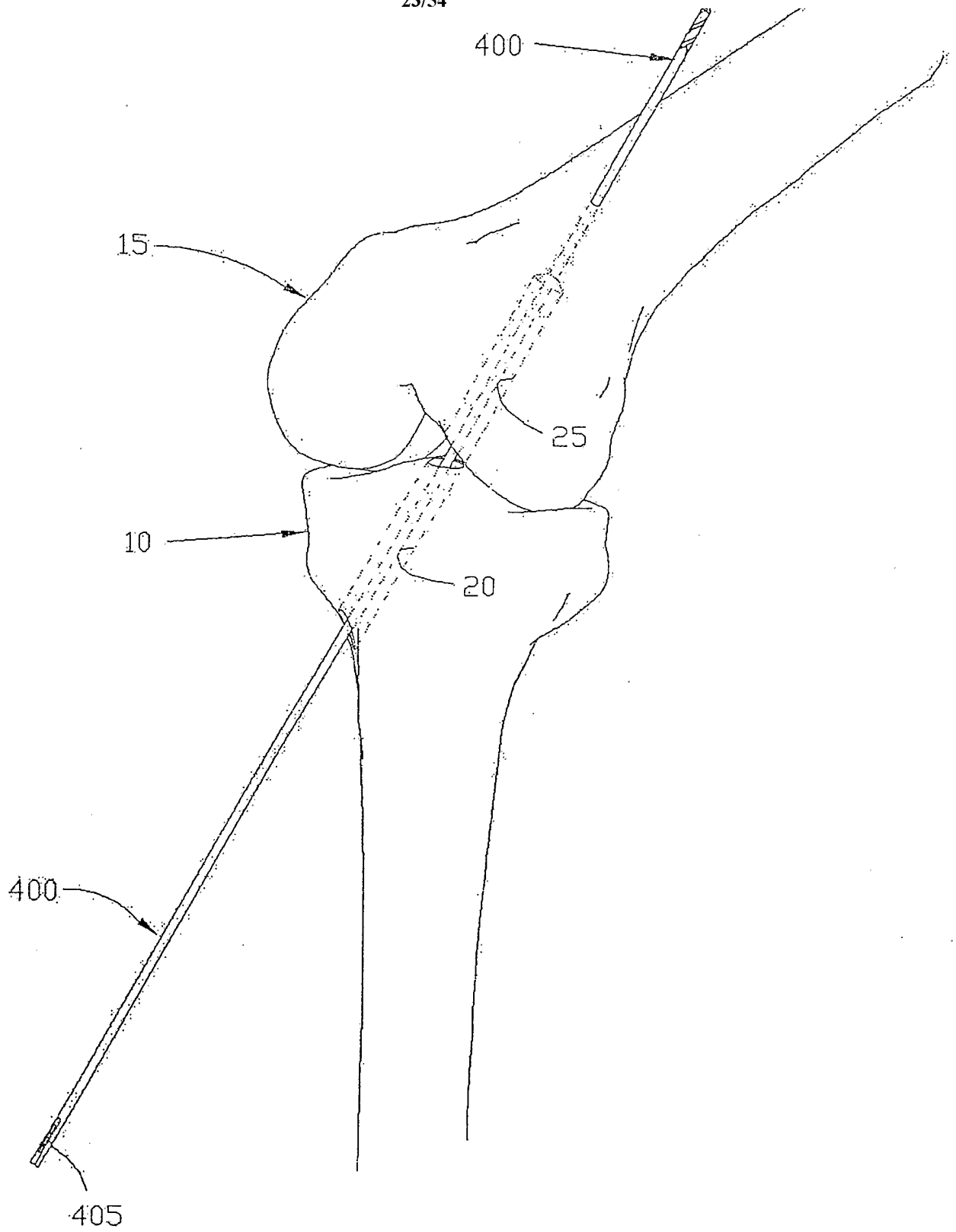

FIG. 24

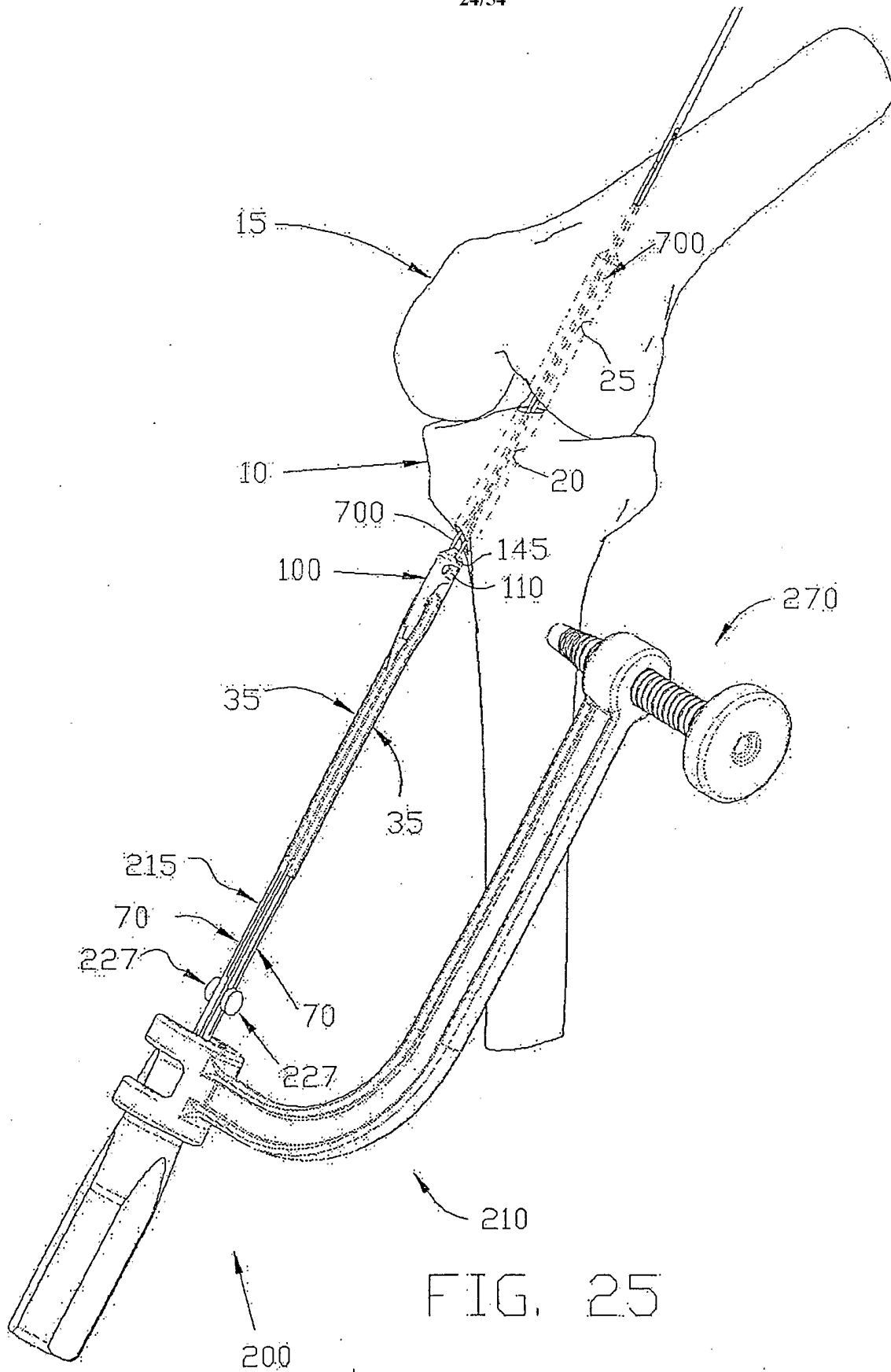

FIG. 25

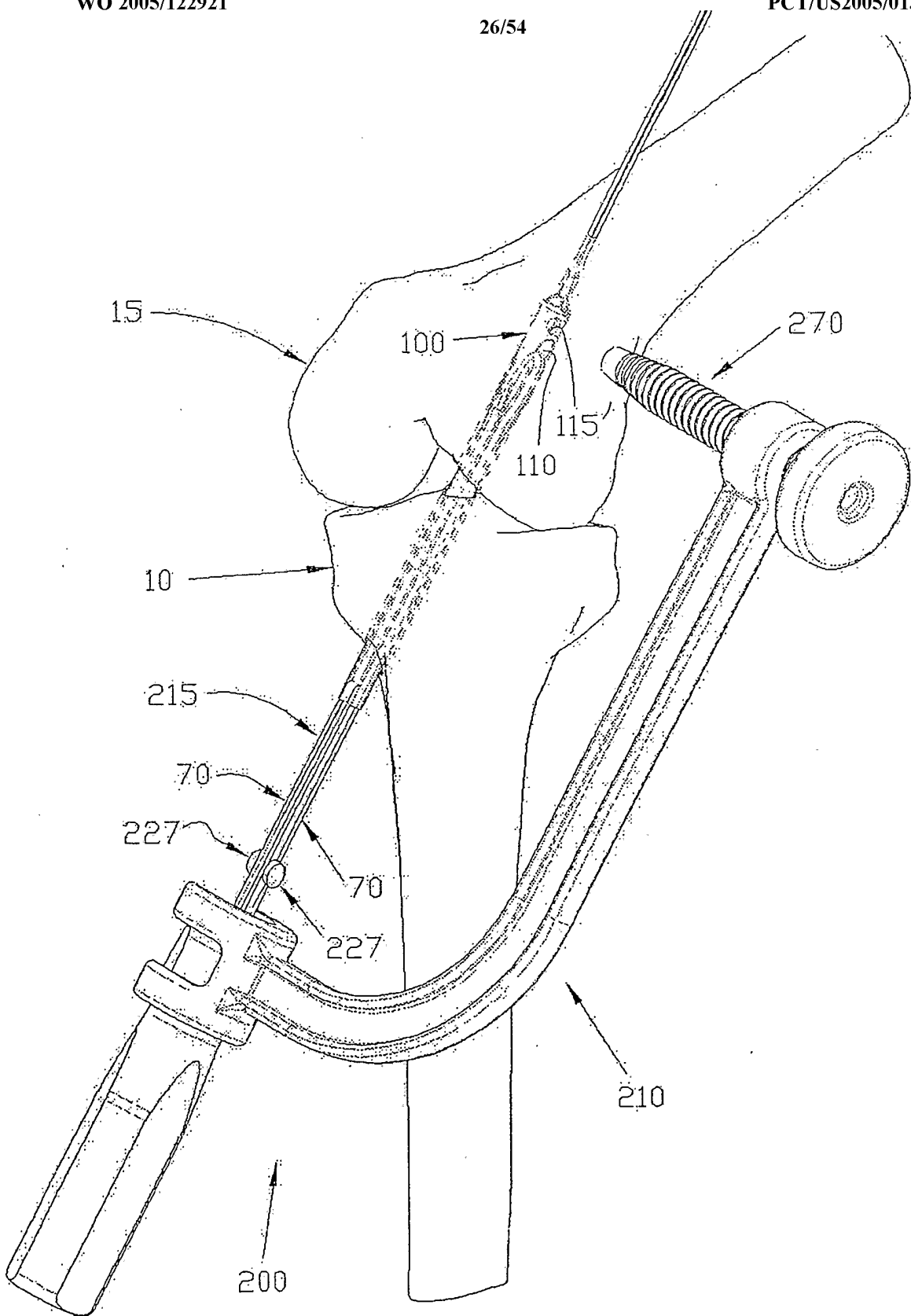

FIG. 27

27/54

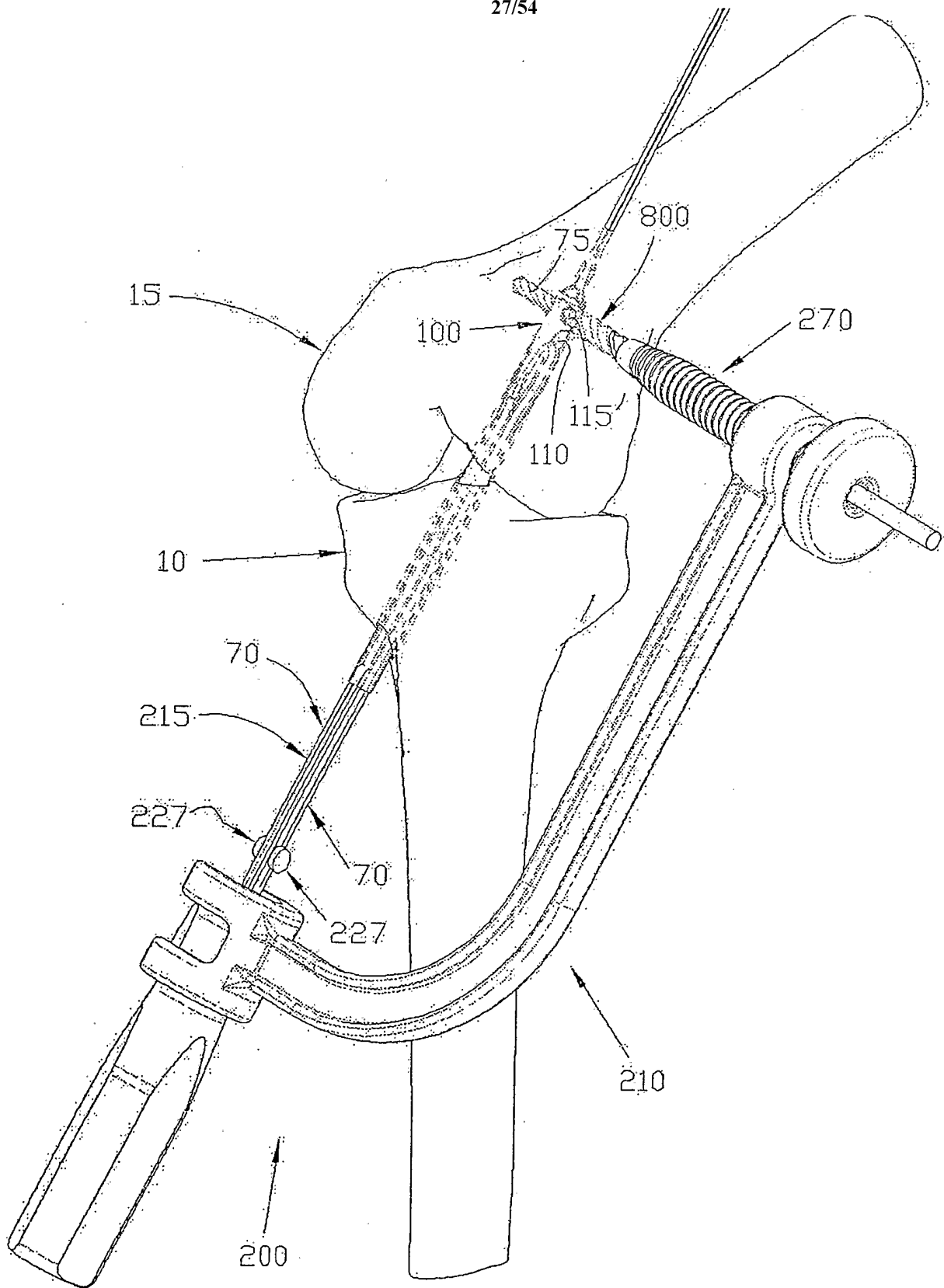

FIG. 28

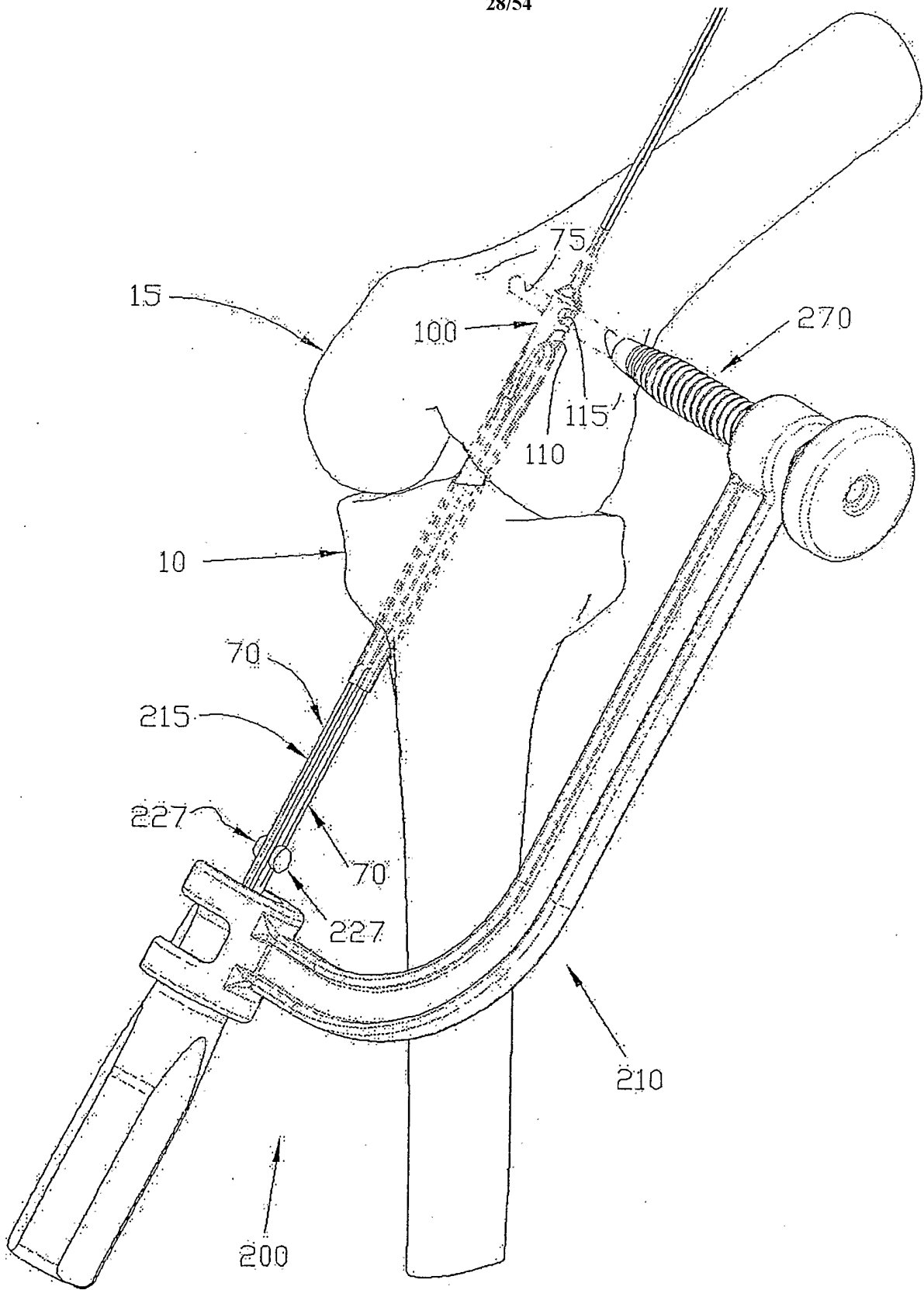

FIG. 29

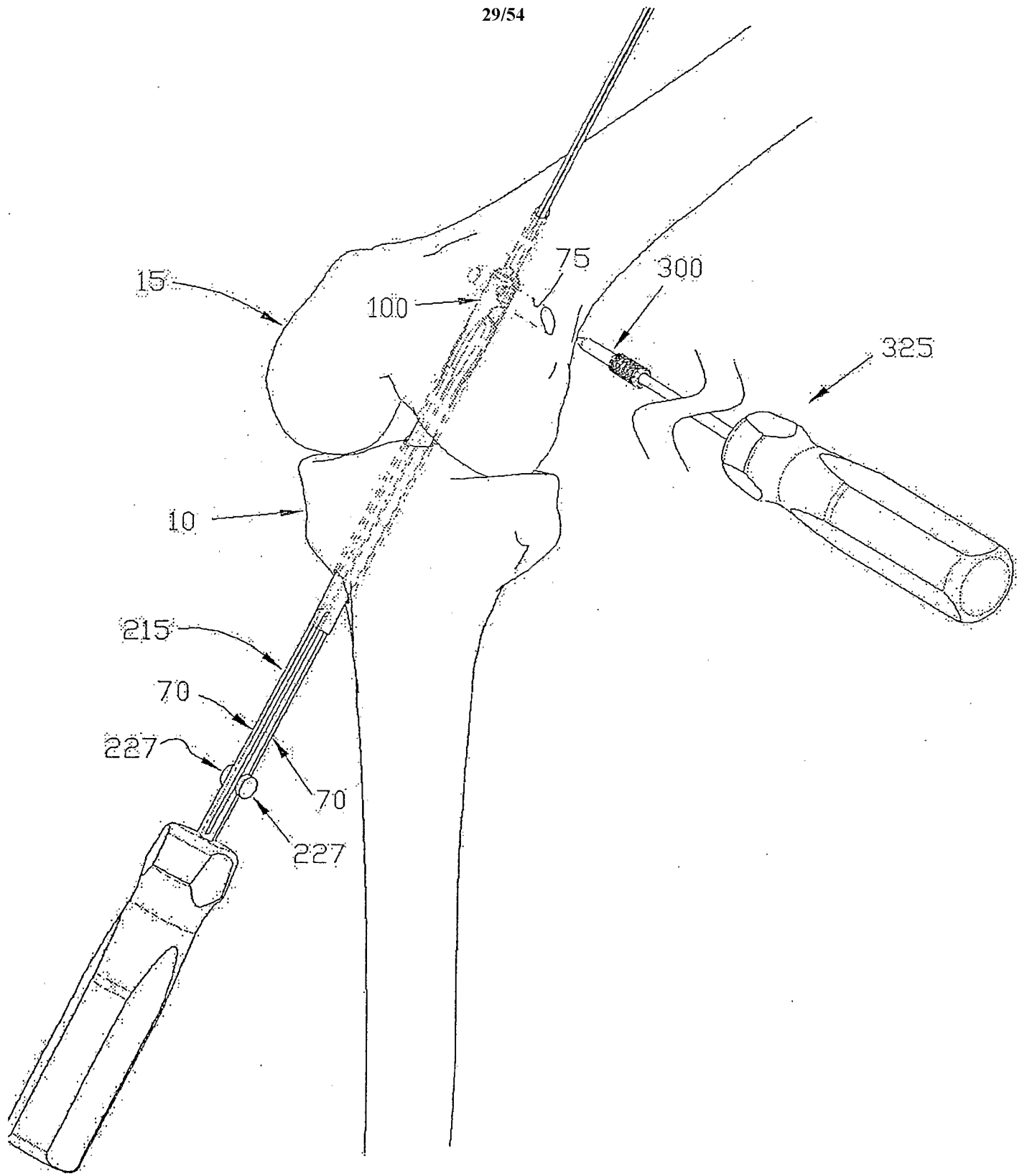

FIG. 30

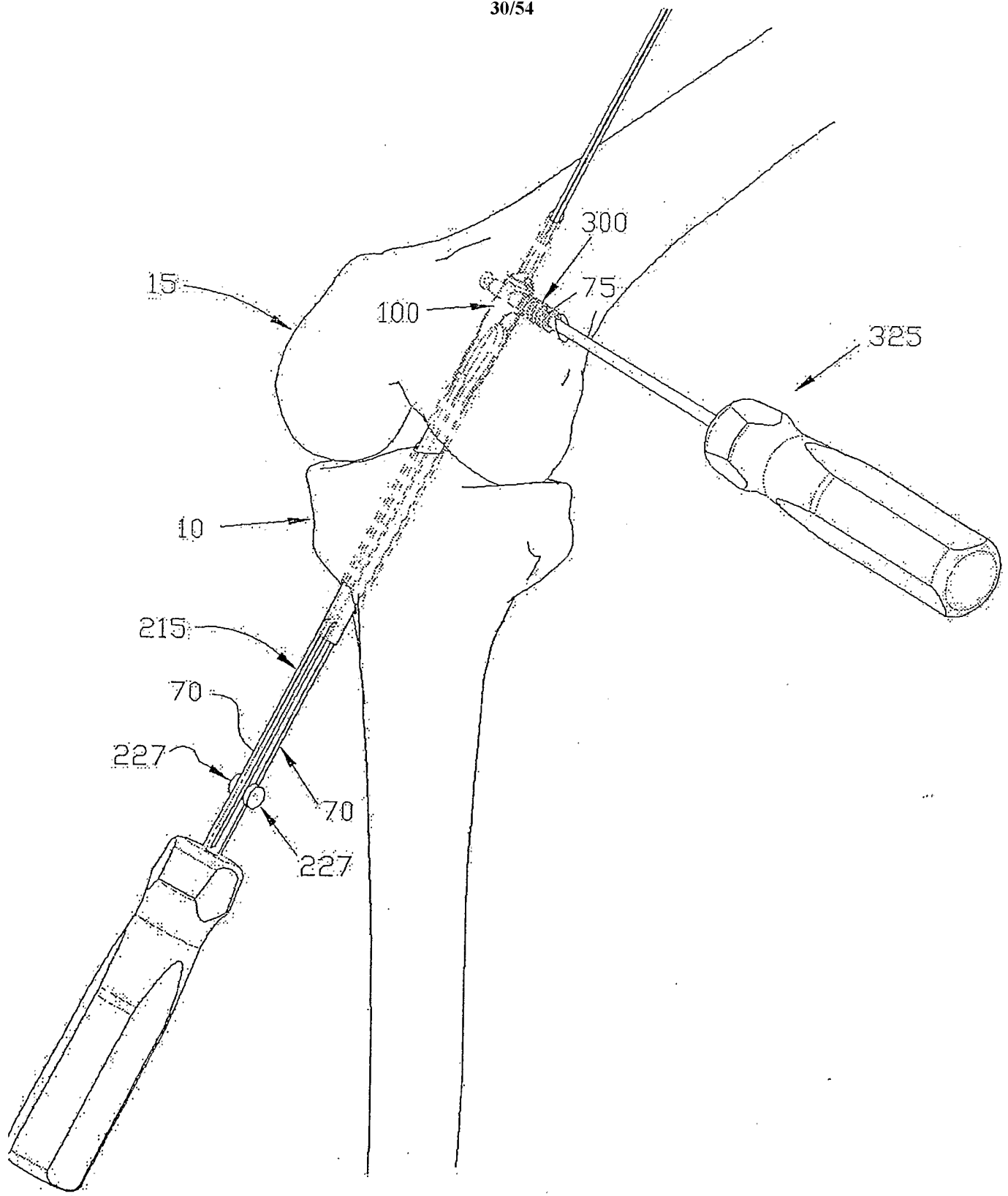

FIG. 31

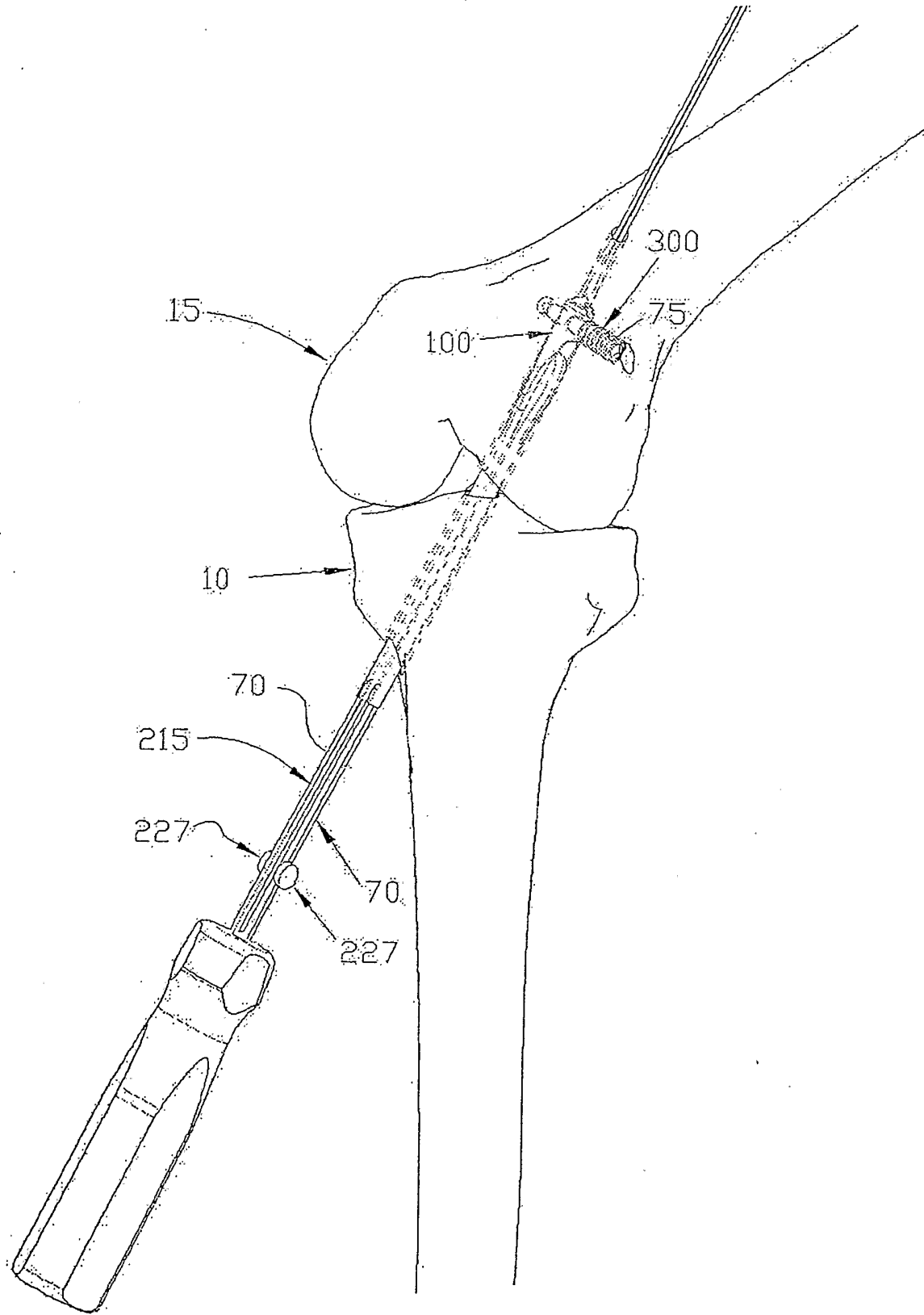

FIG. 32

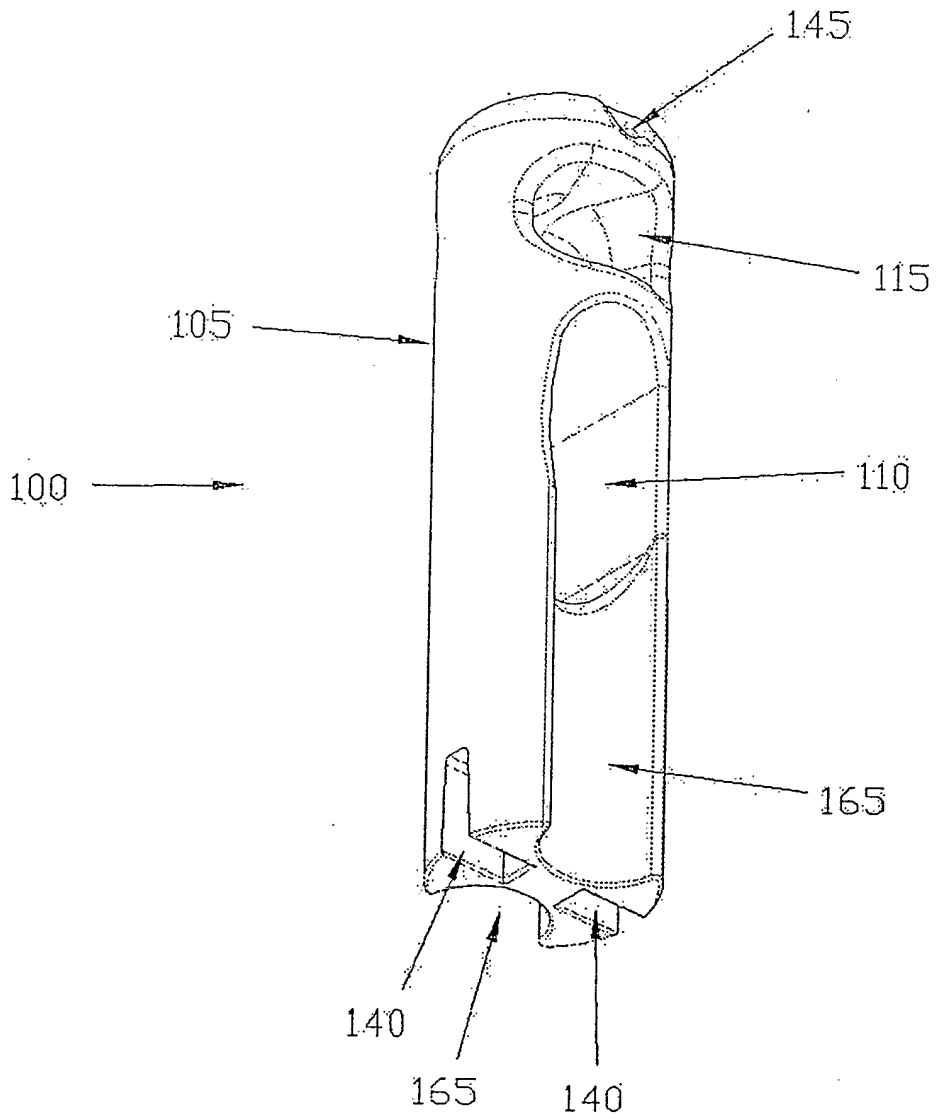

FIG. 34

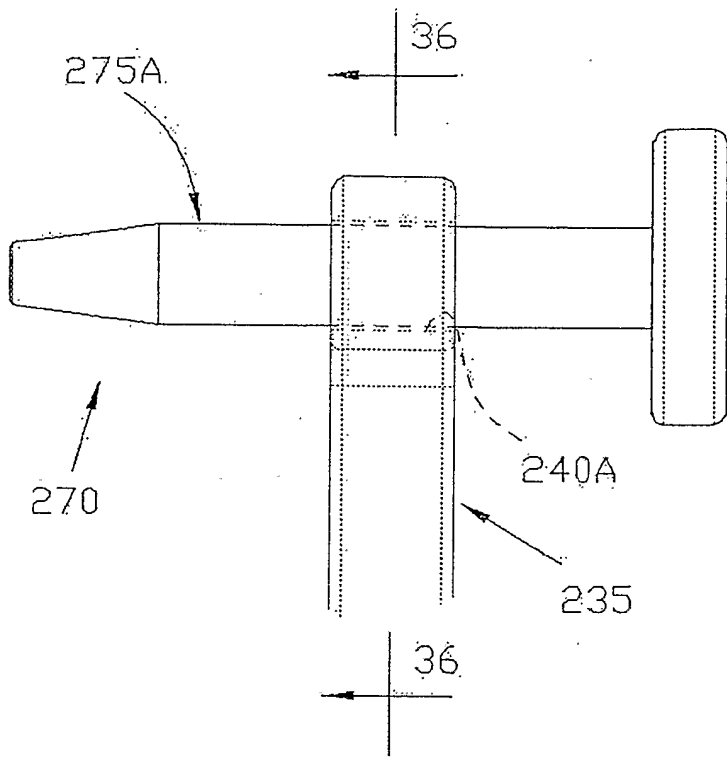

FIG. 35

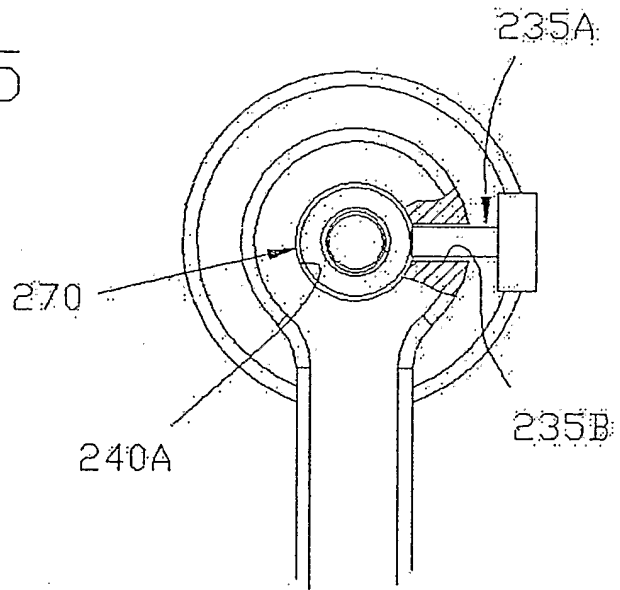

FIG. 36

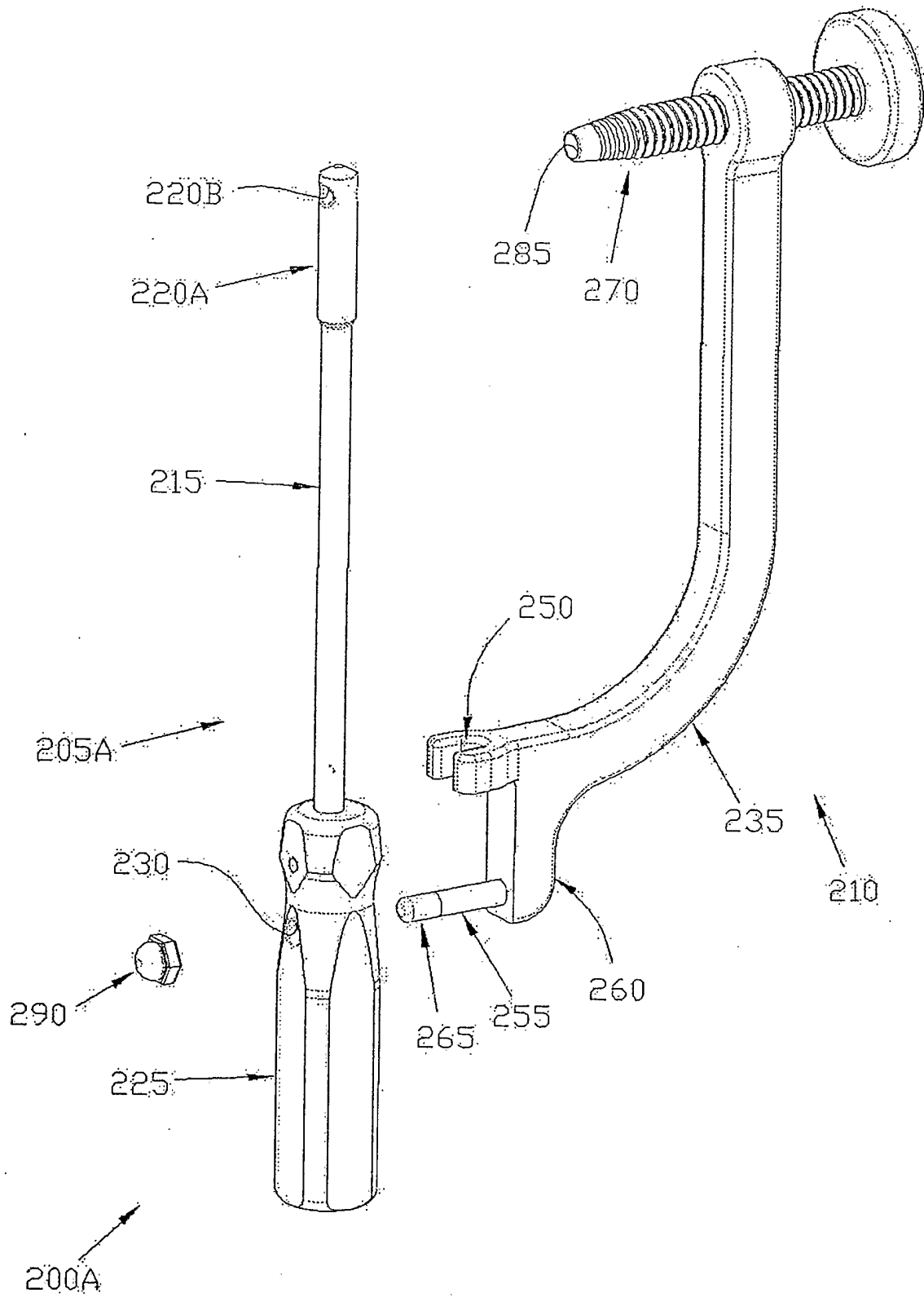

FIG. 37

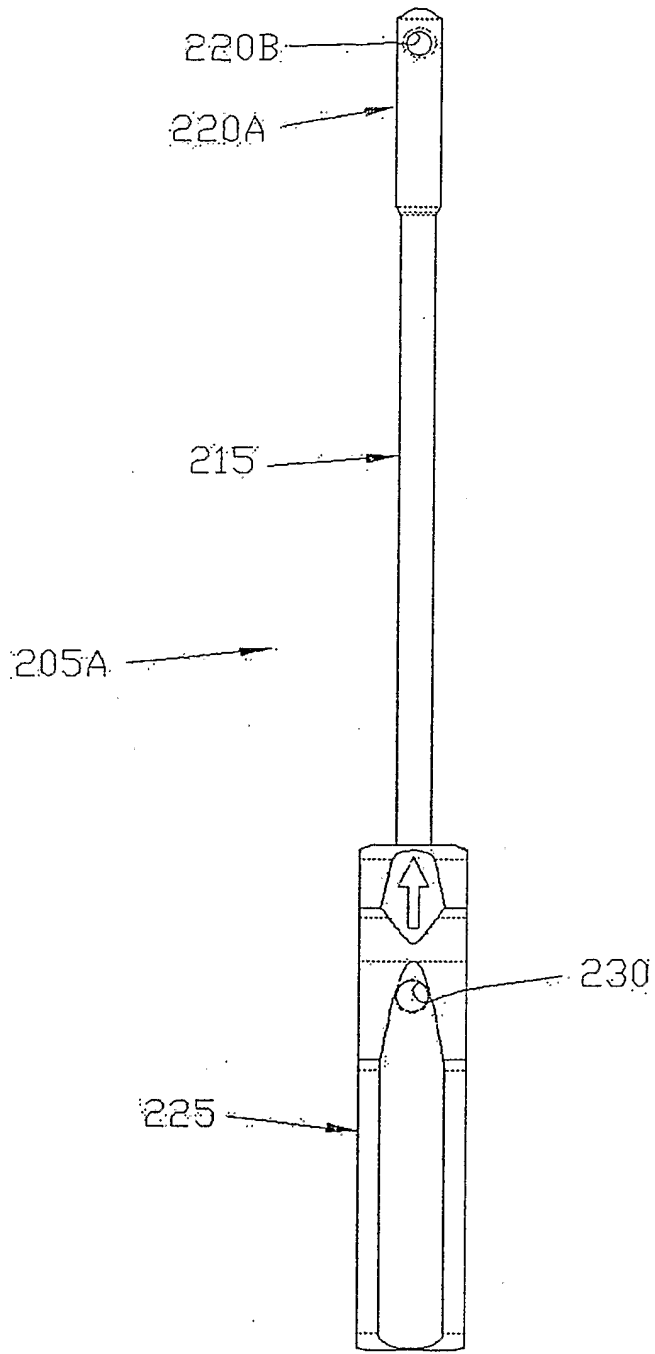

FIG. 38

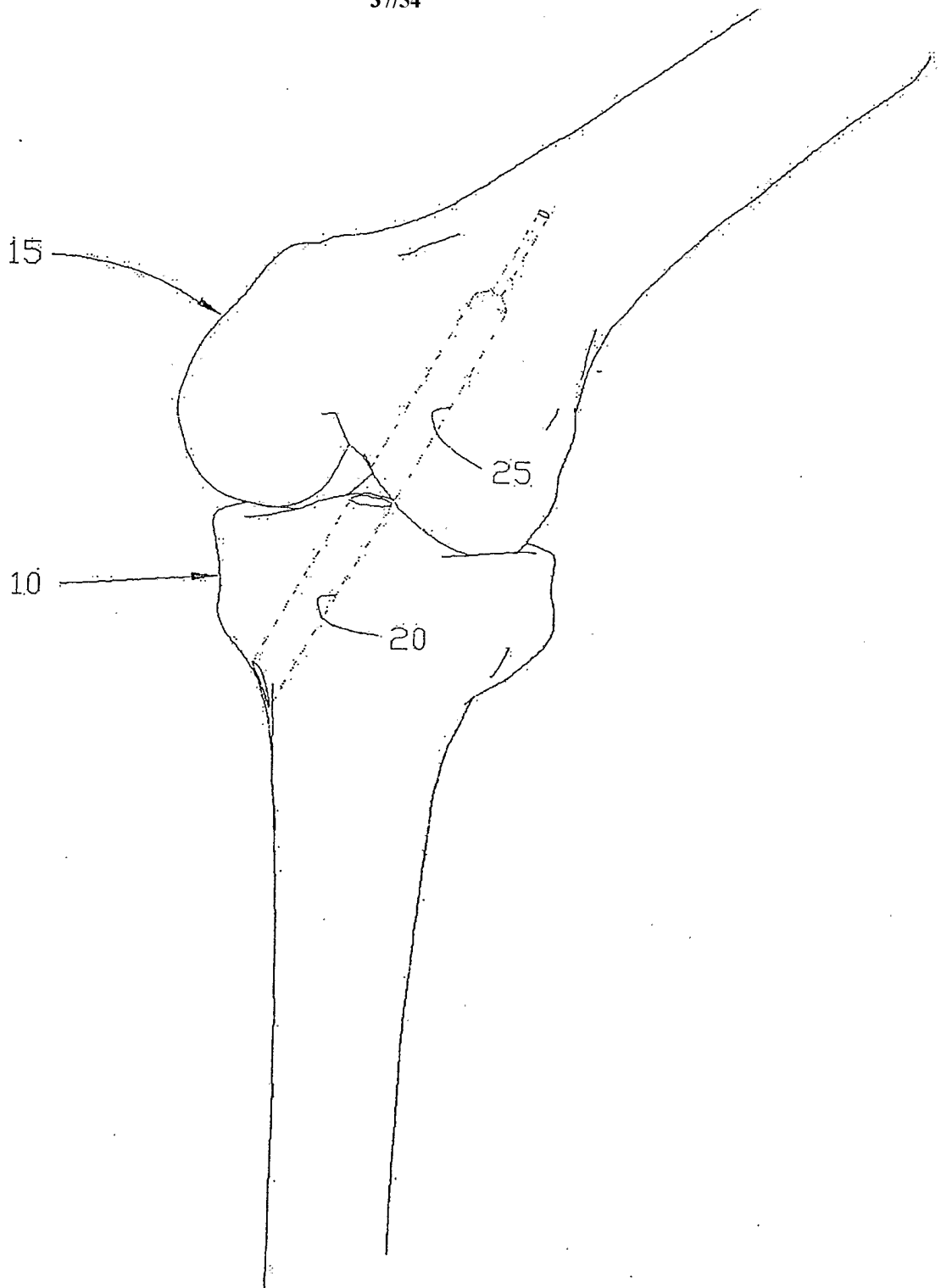

FIG. 39

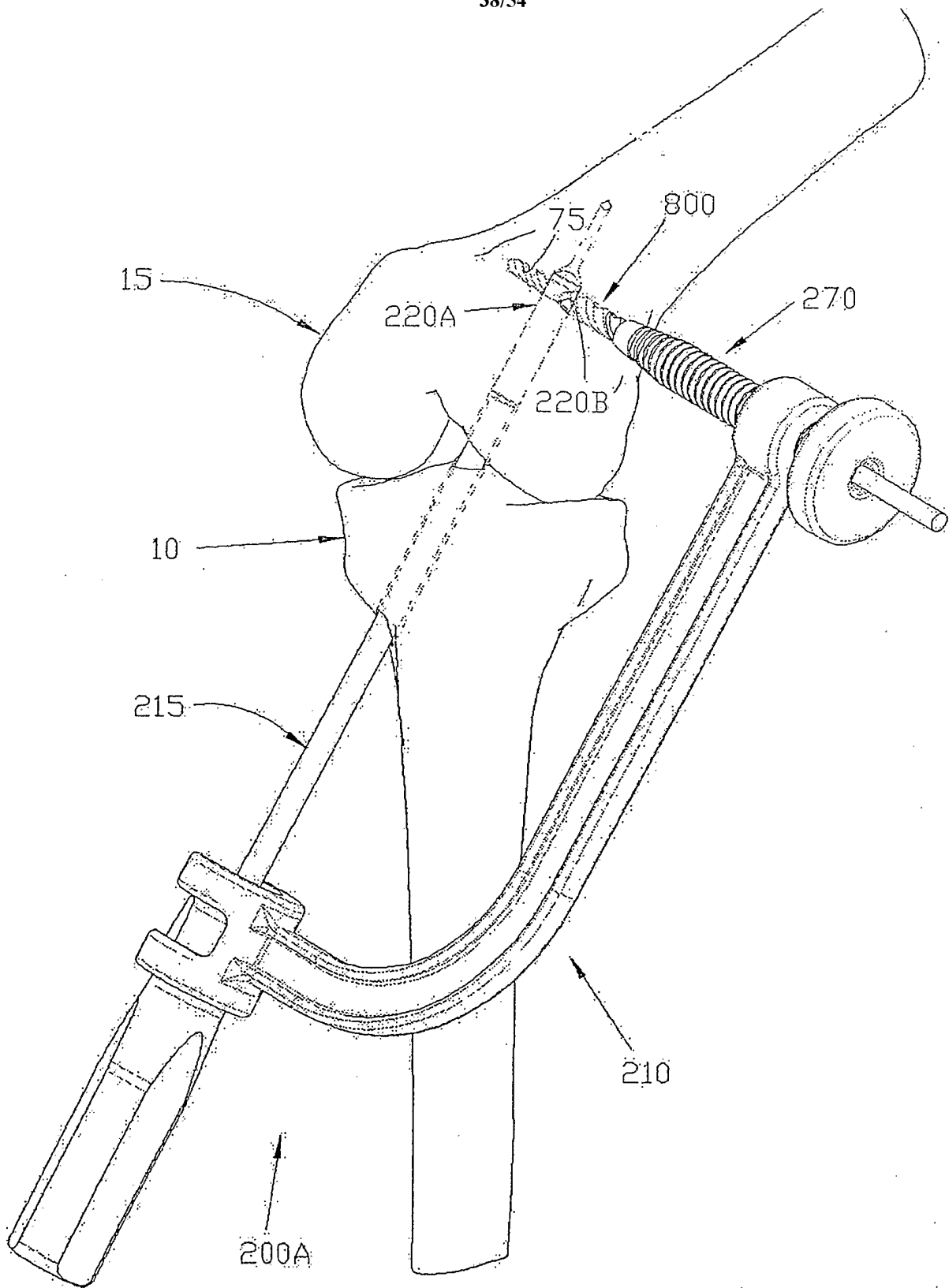

FIG. 40

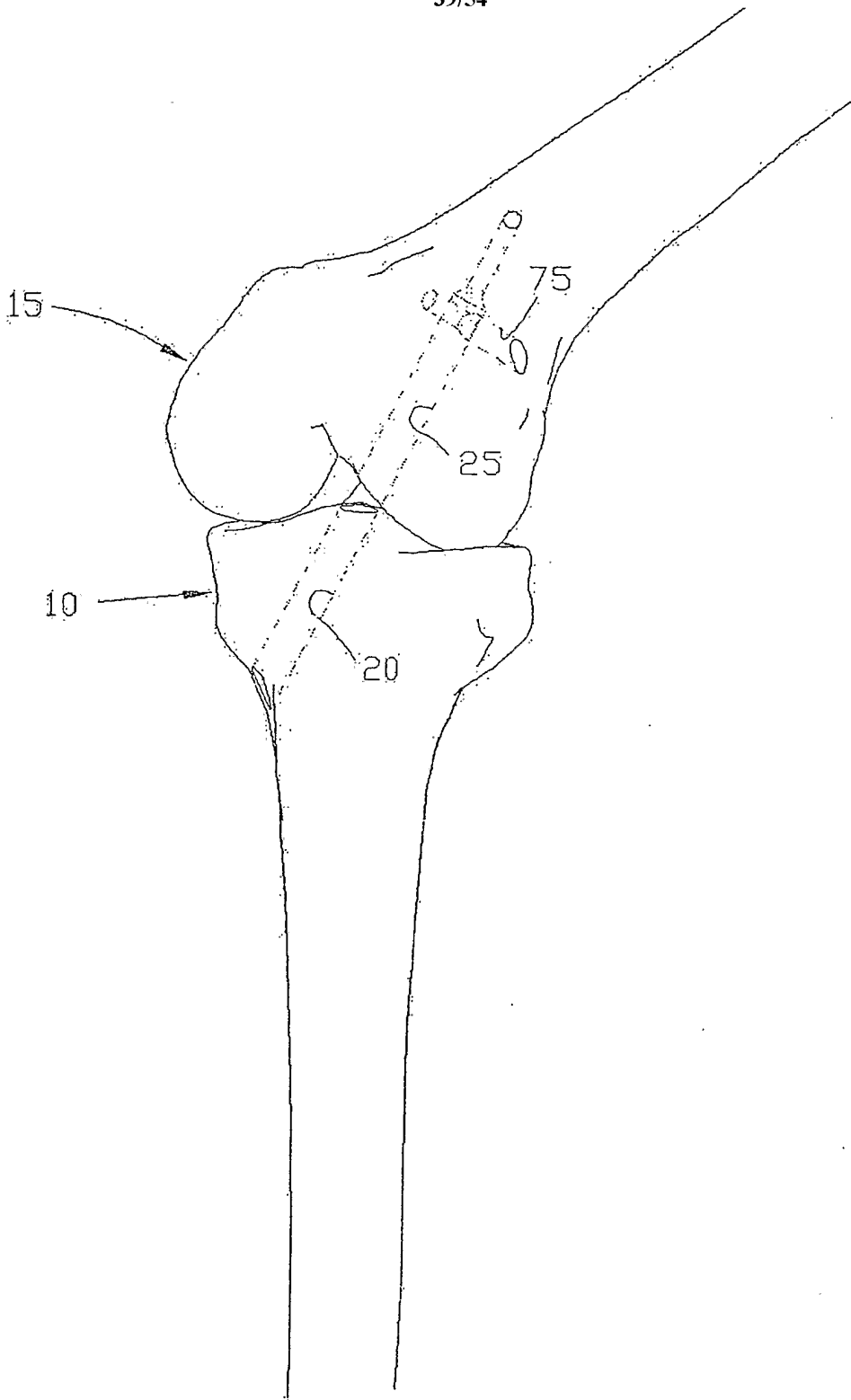

FIG. 41

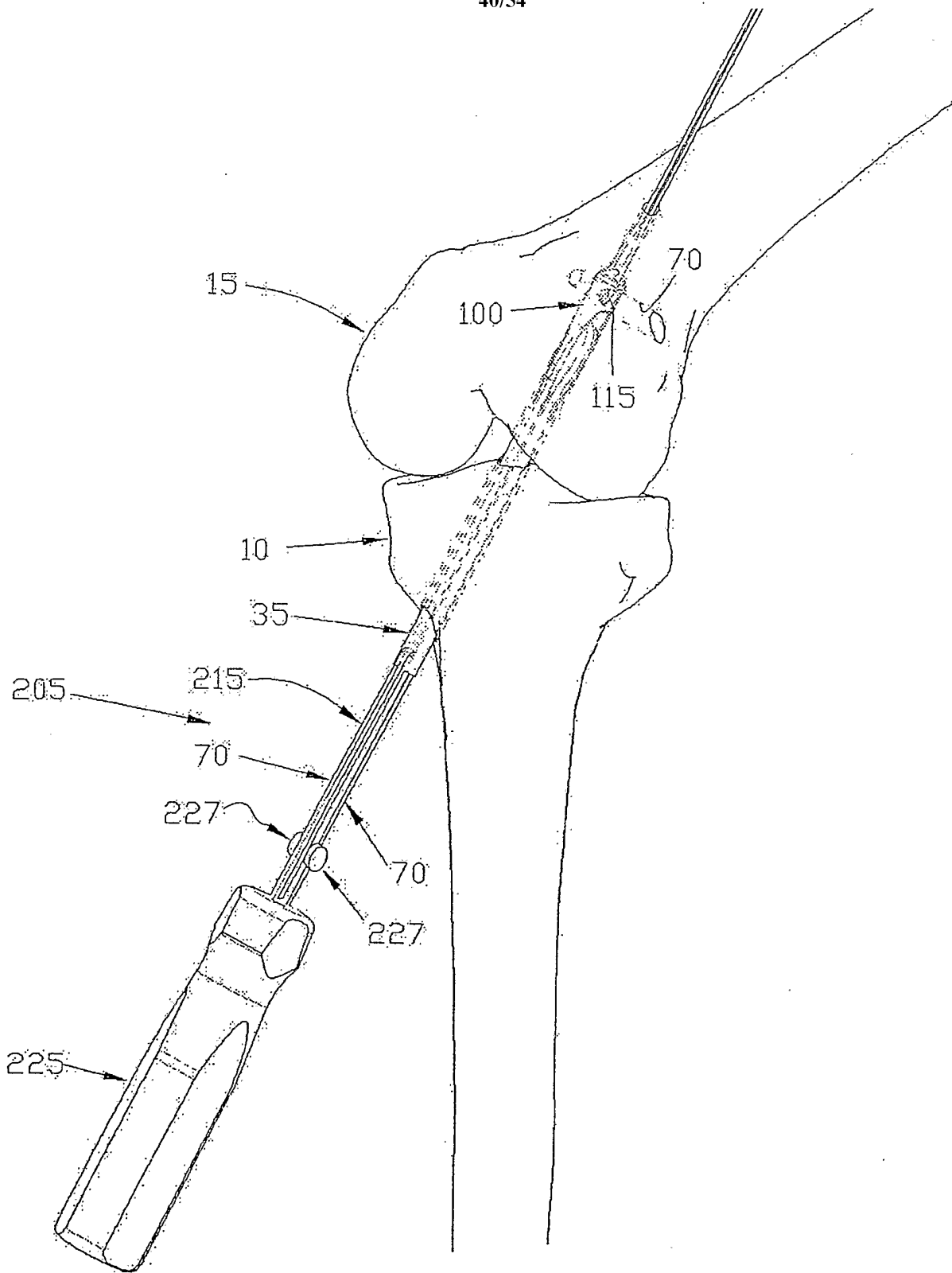

FIG. 42

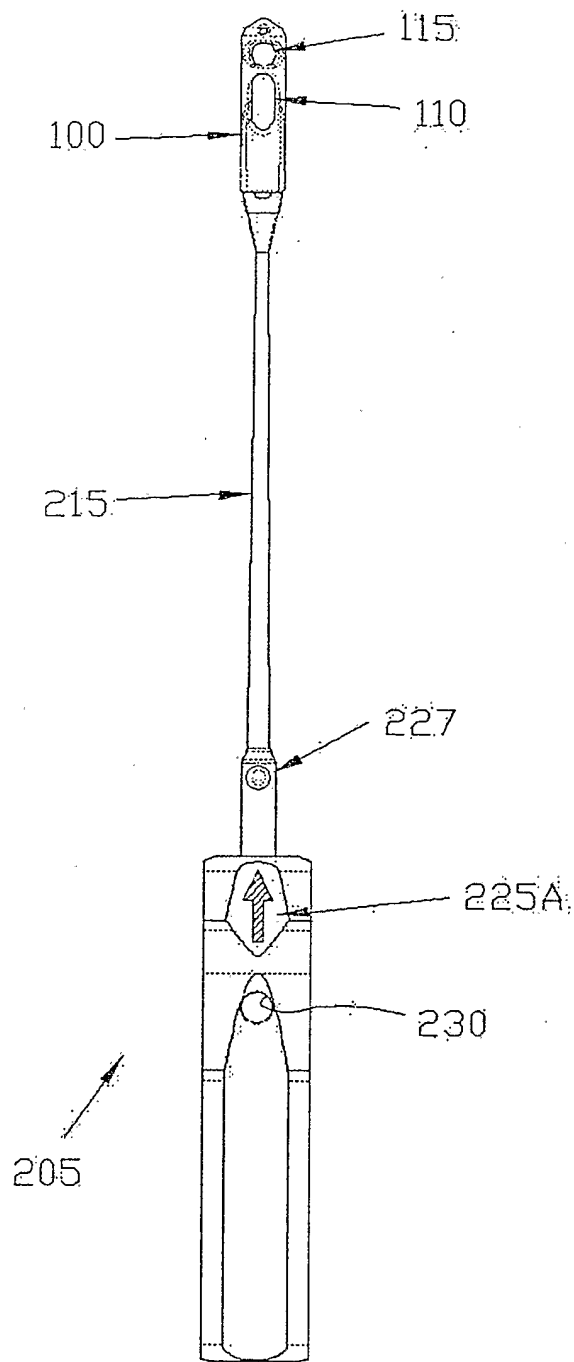

FIG. 43

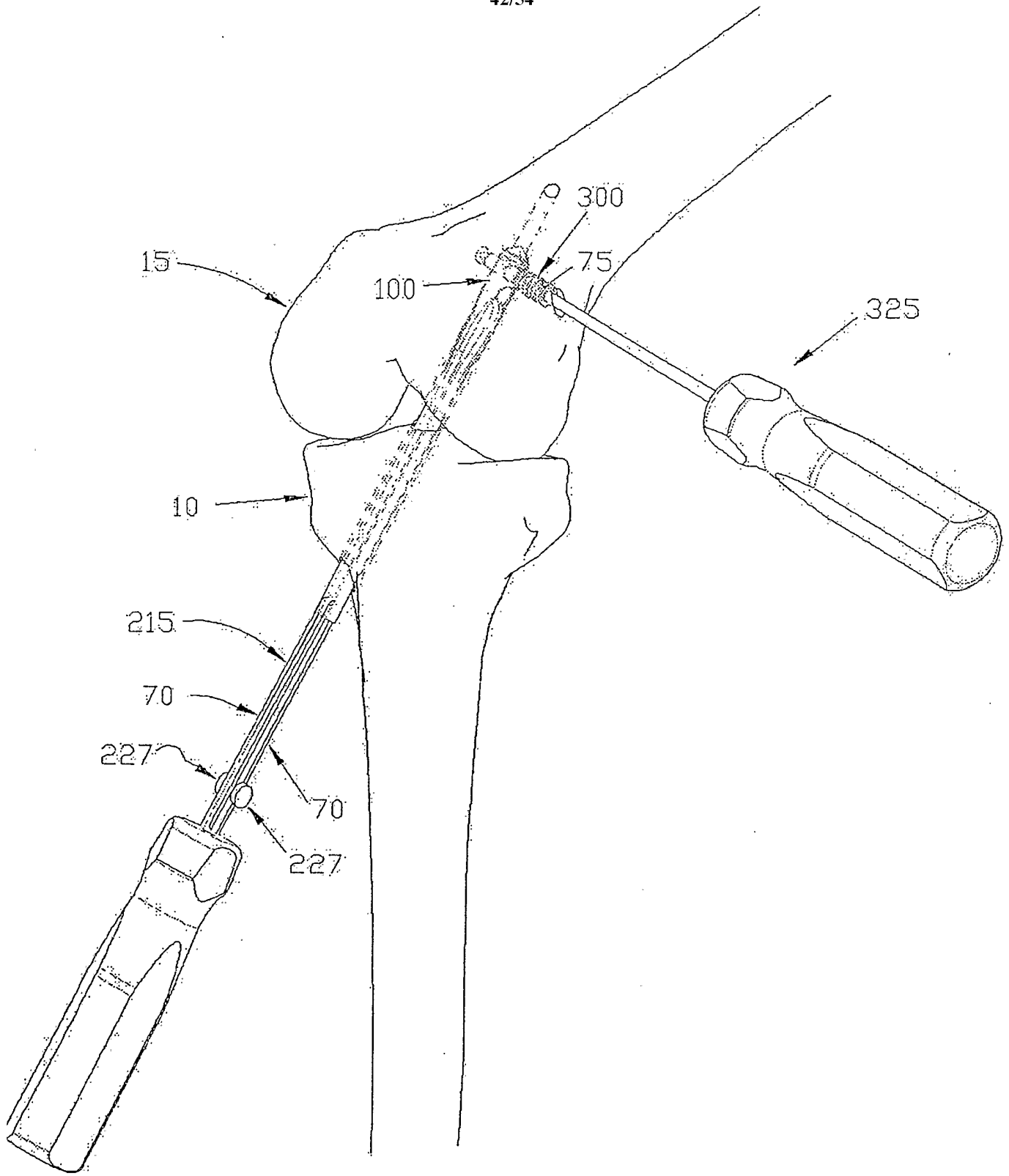

FIG. 44

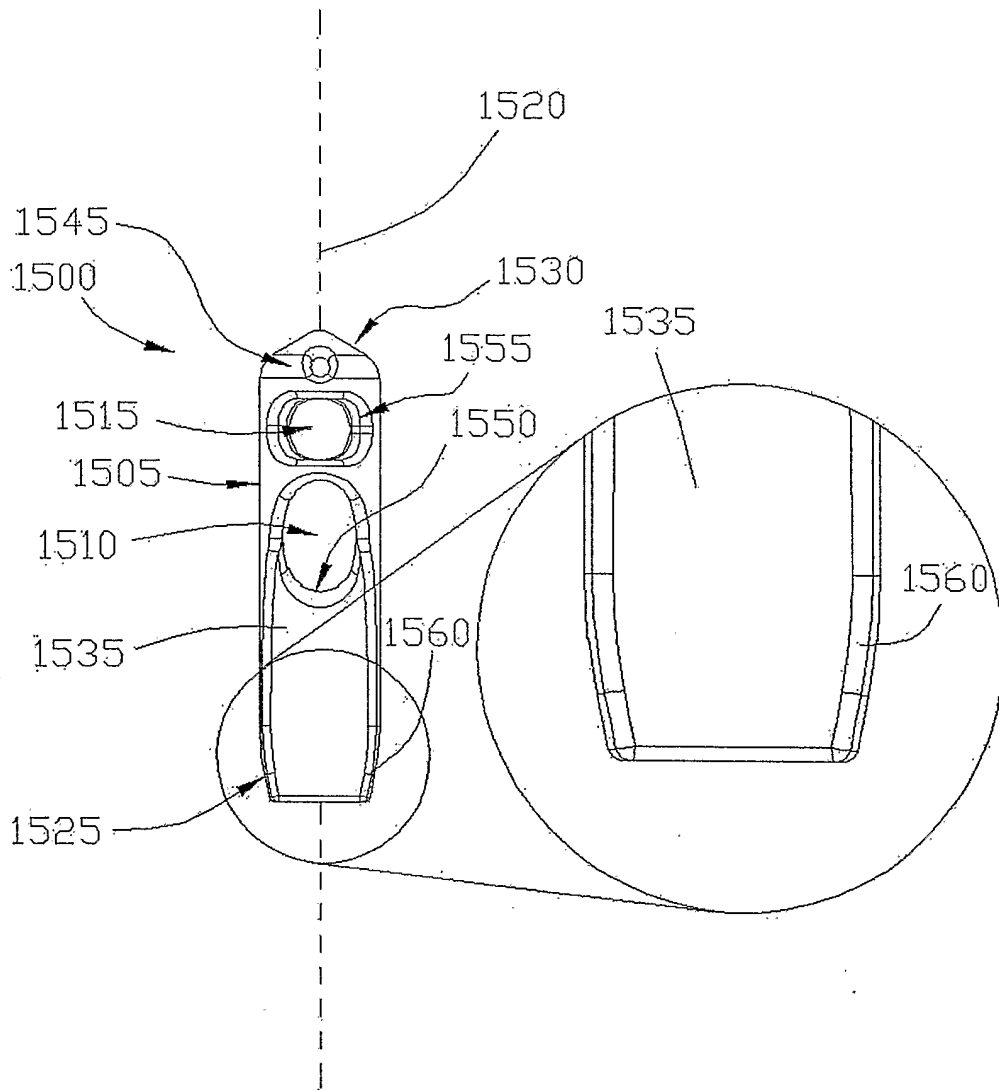

FIG. 45

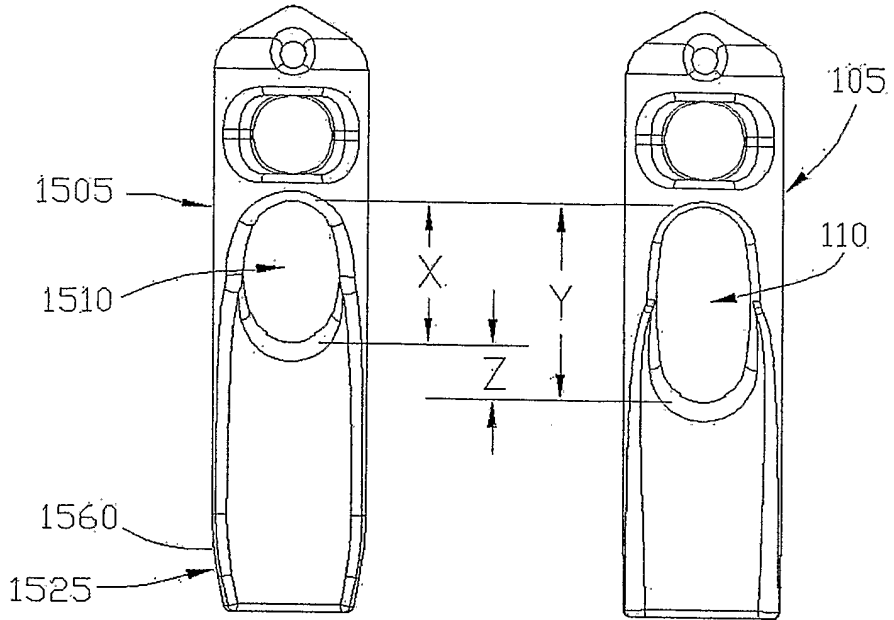

FIG. 46A FIG. 46B

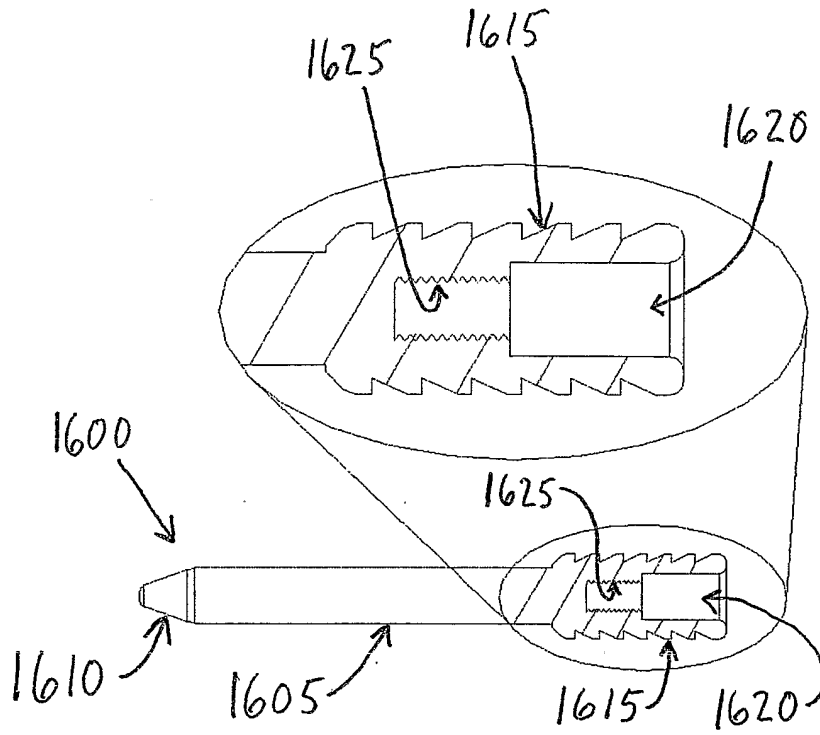

FIG. 47

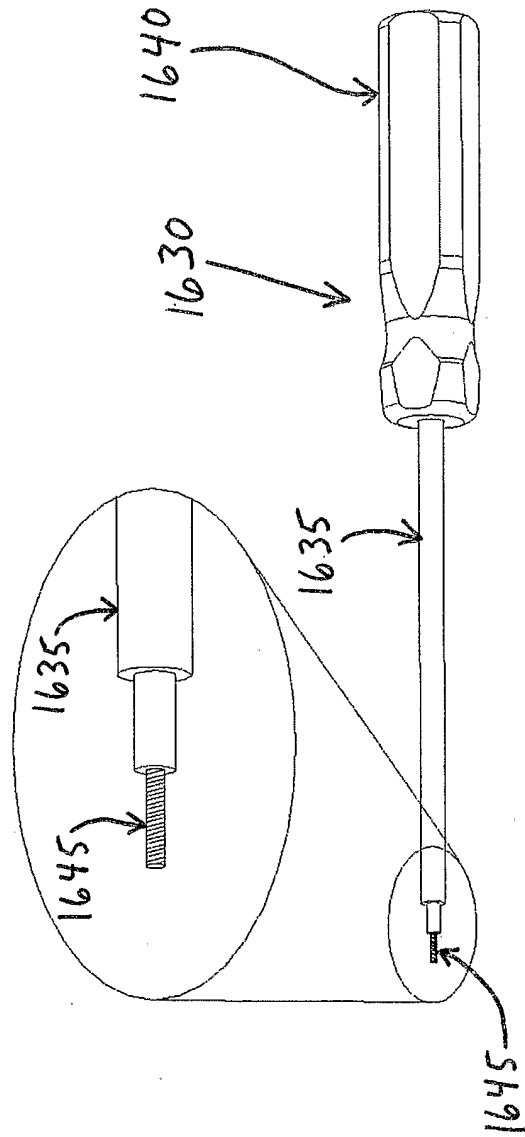

FIG. 48

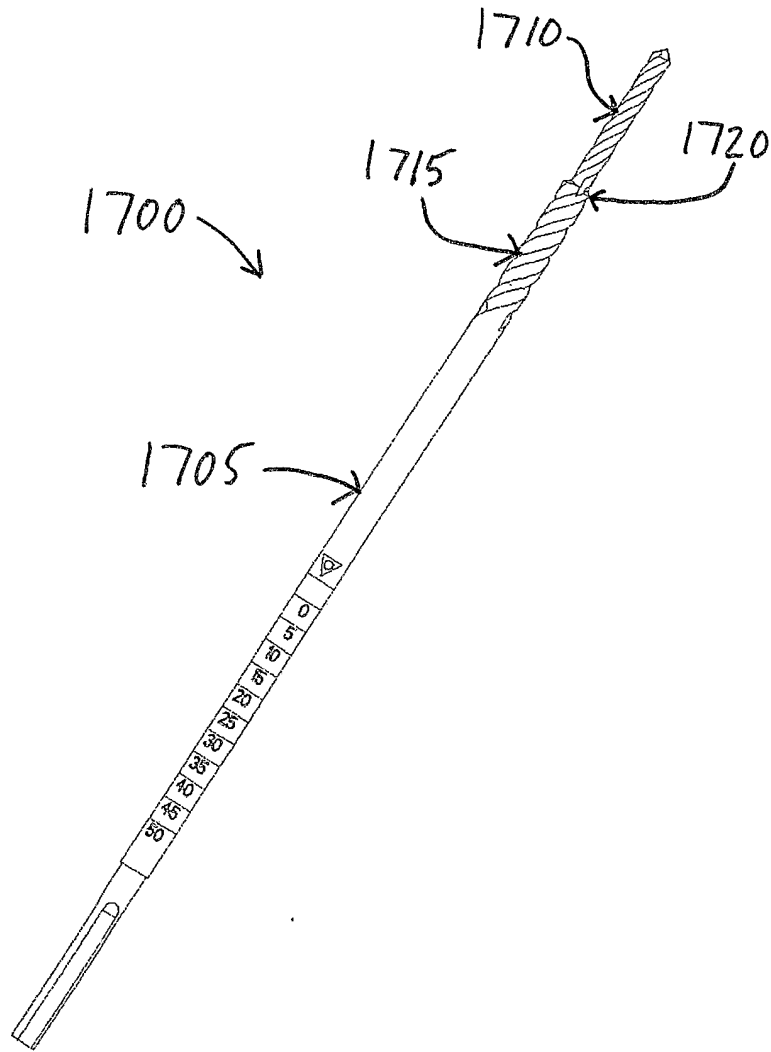

FIG. 49

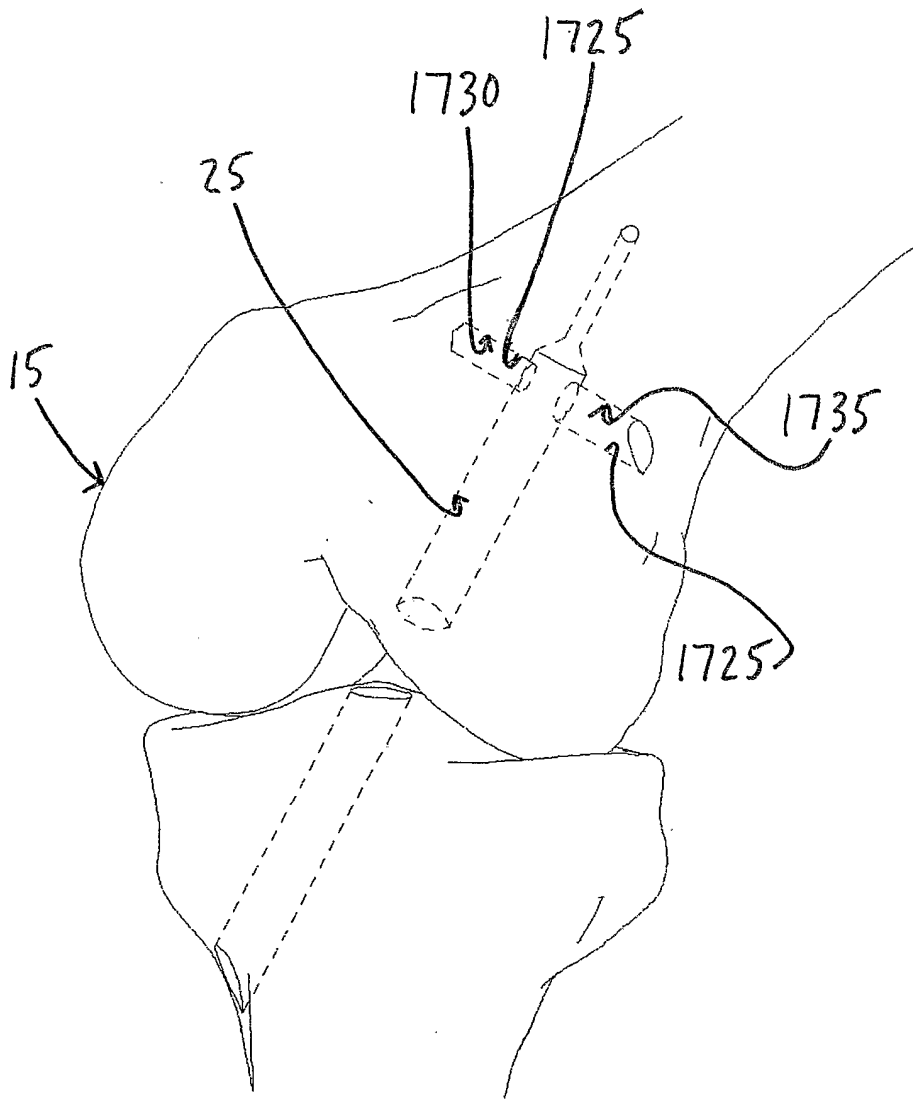
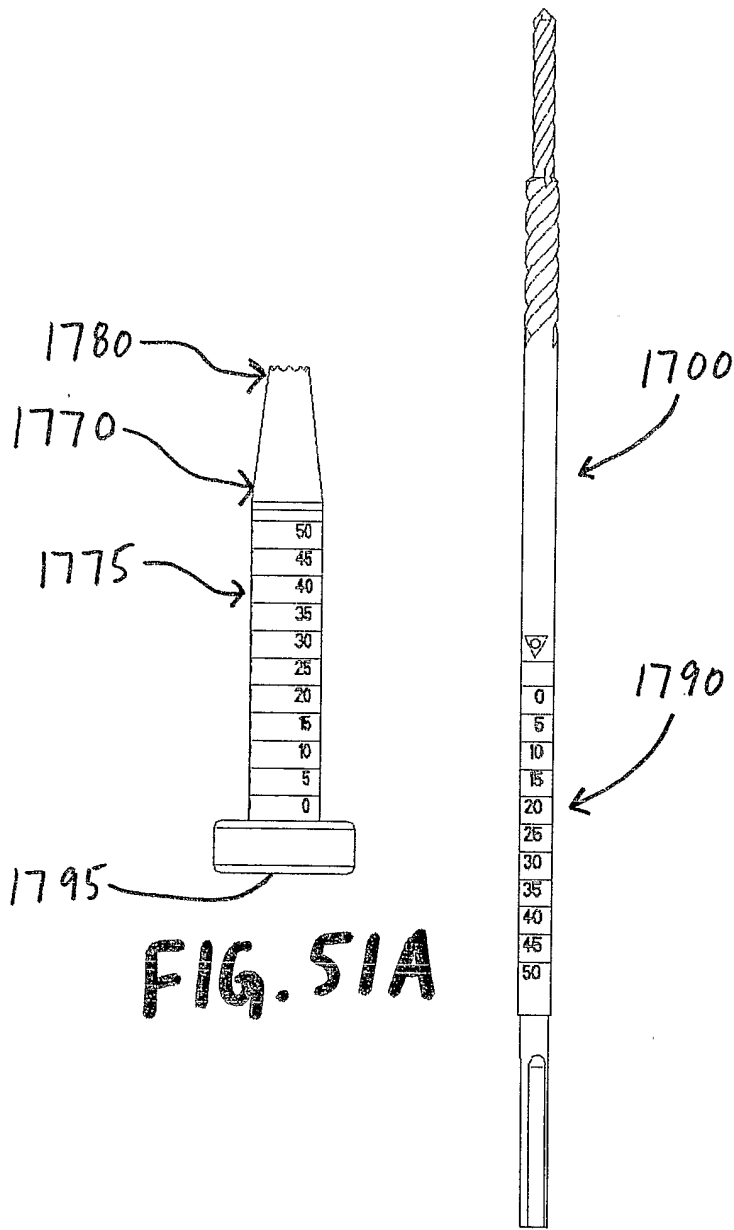

FIG. 50



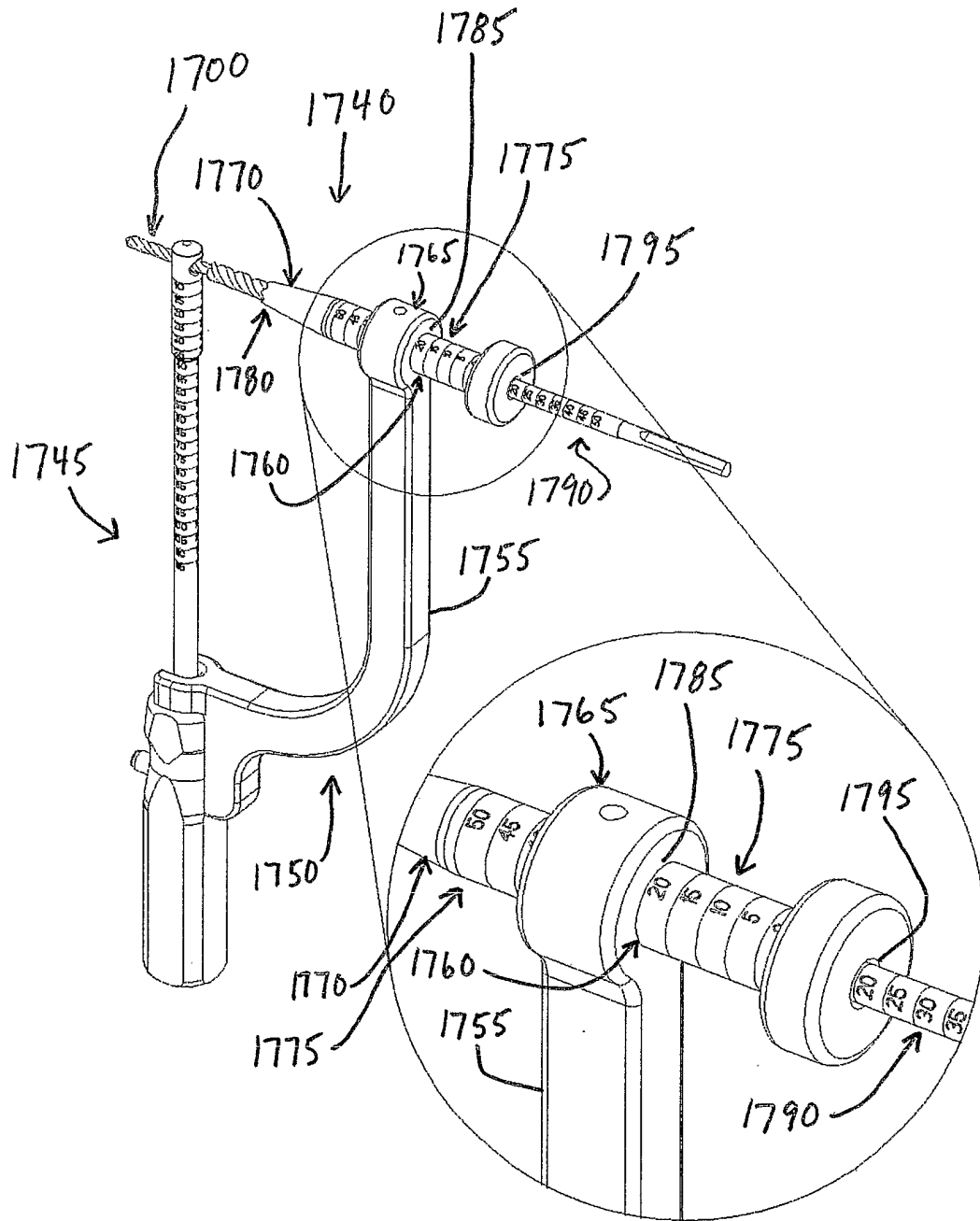

FIG. 52

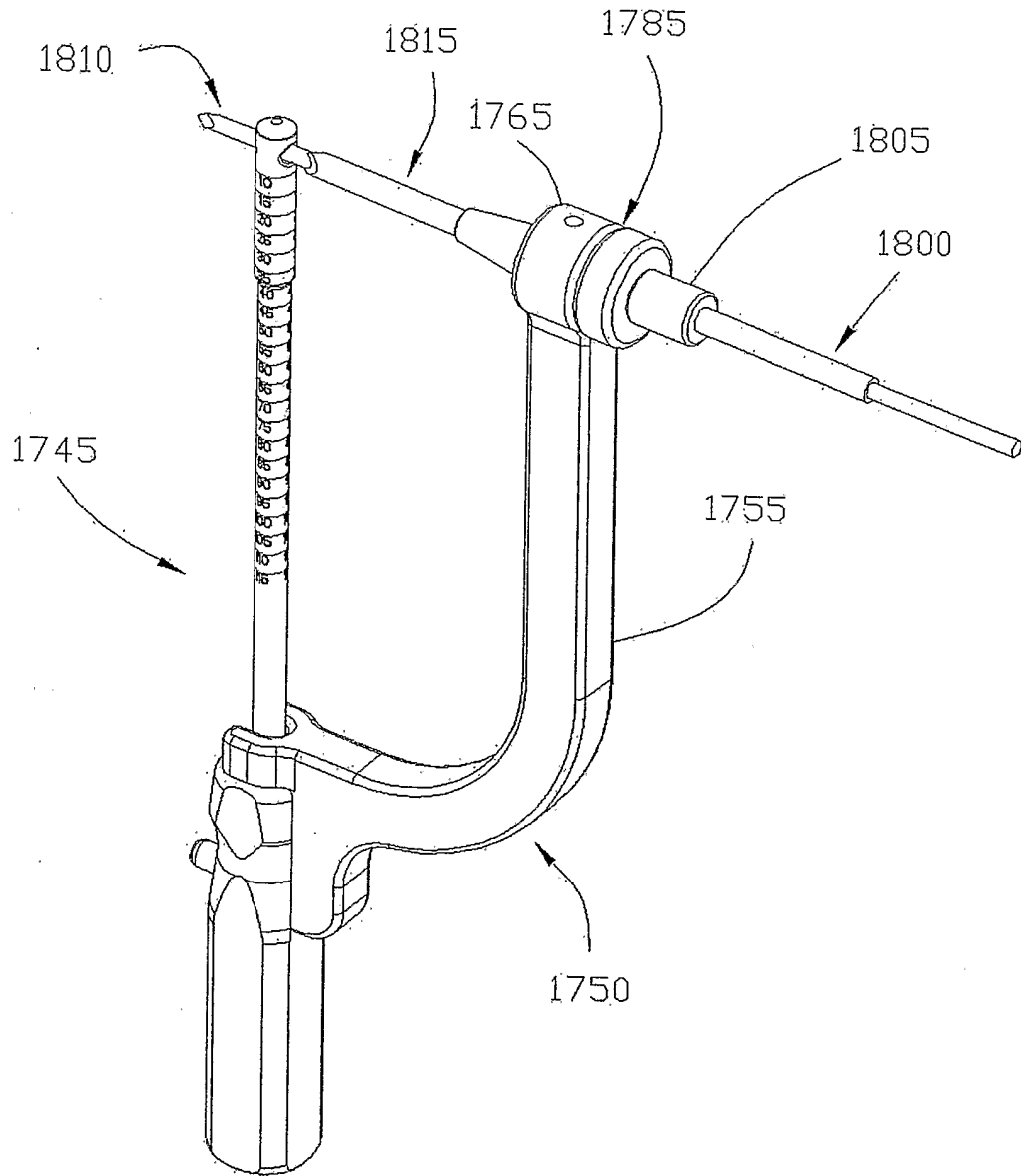
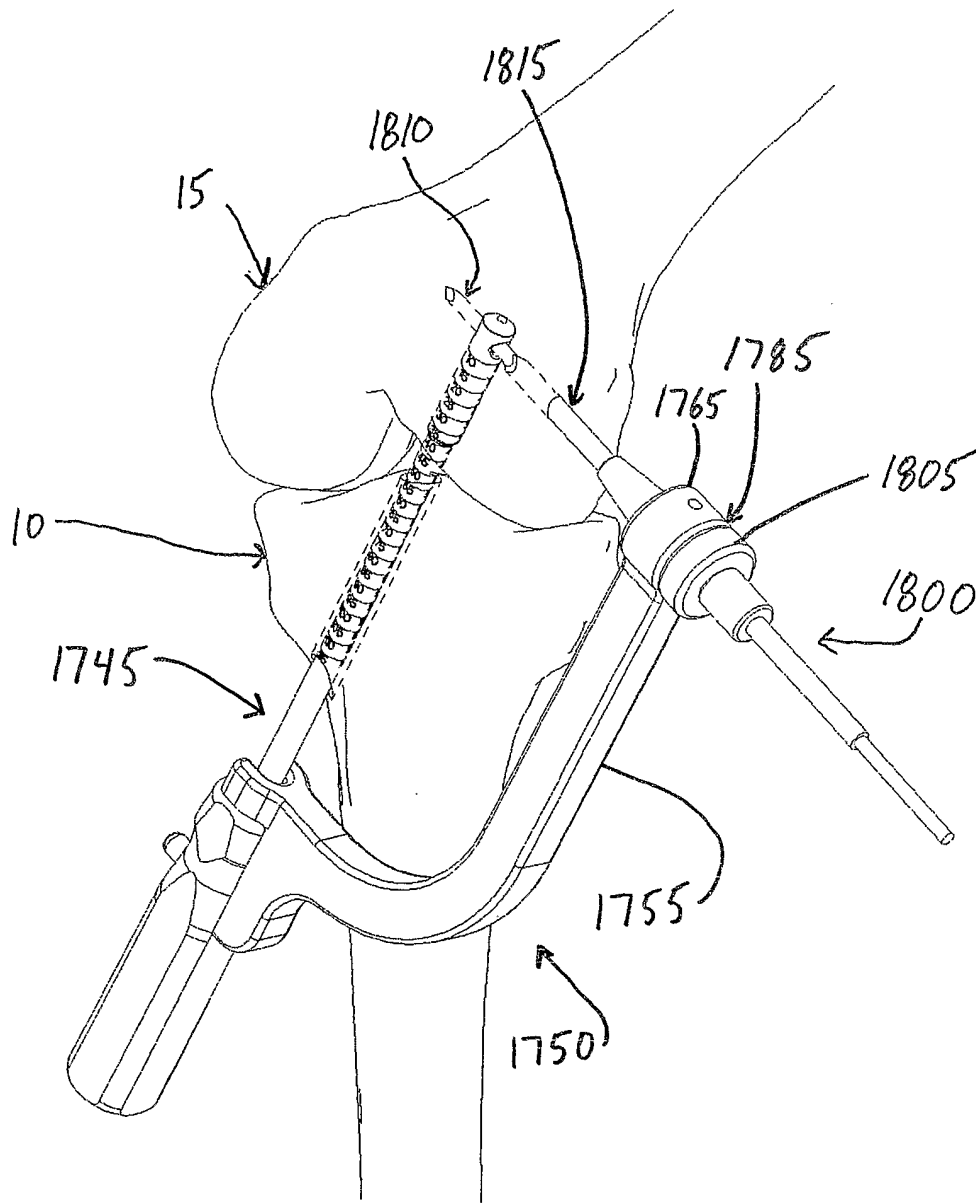

FIG. 53



F 16. 54

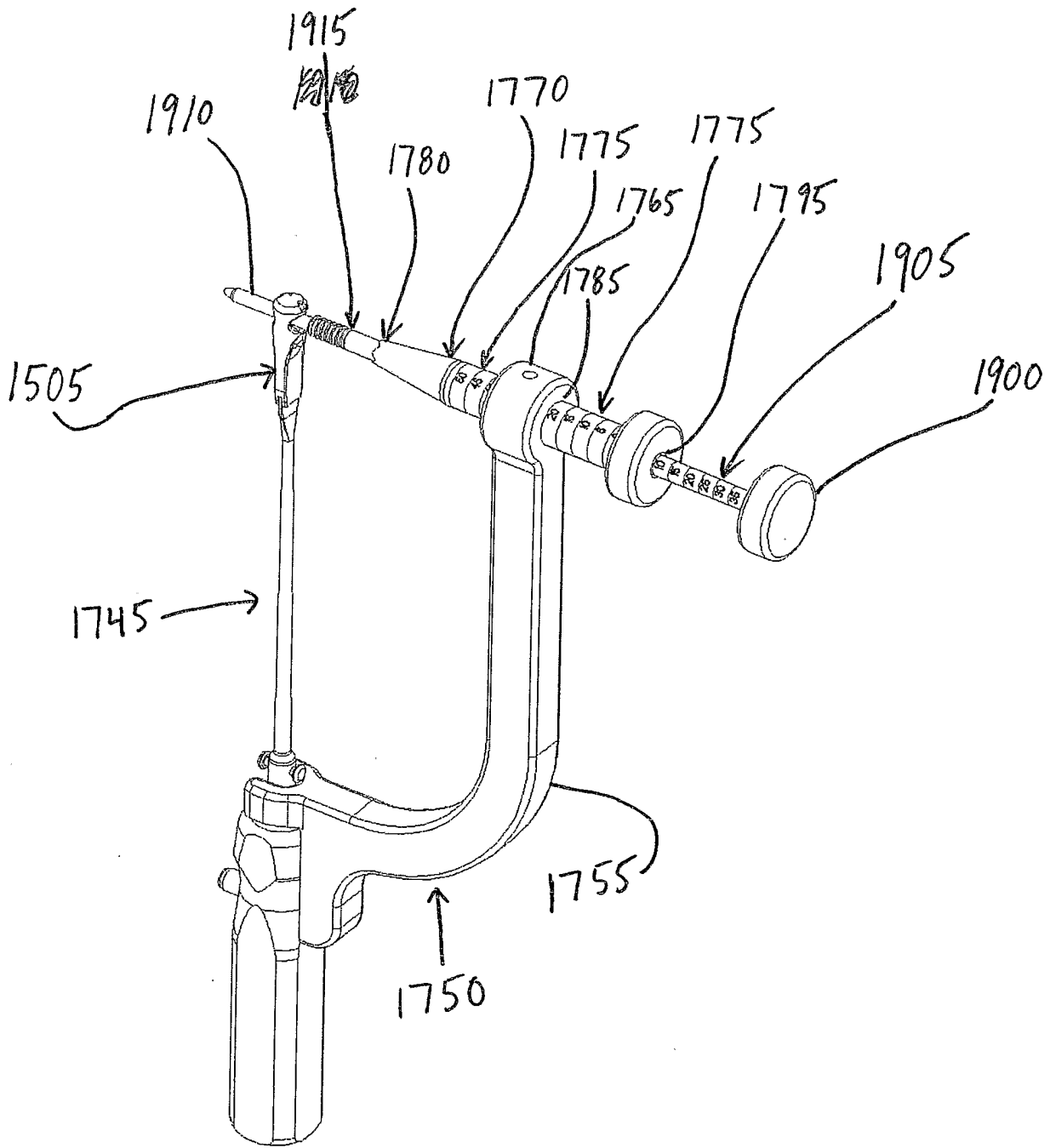

FIG. 55

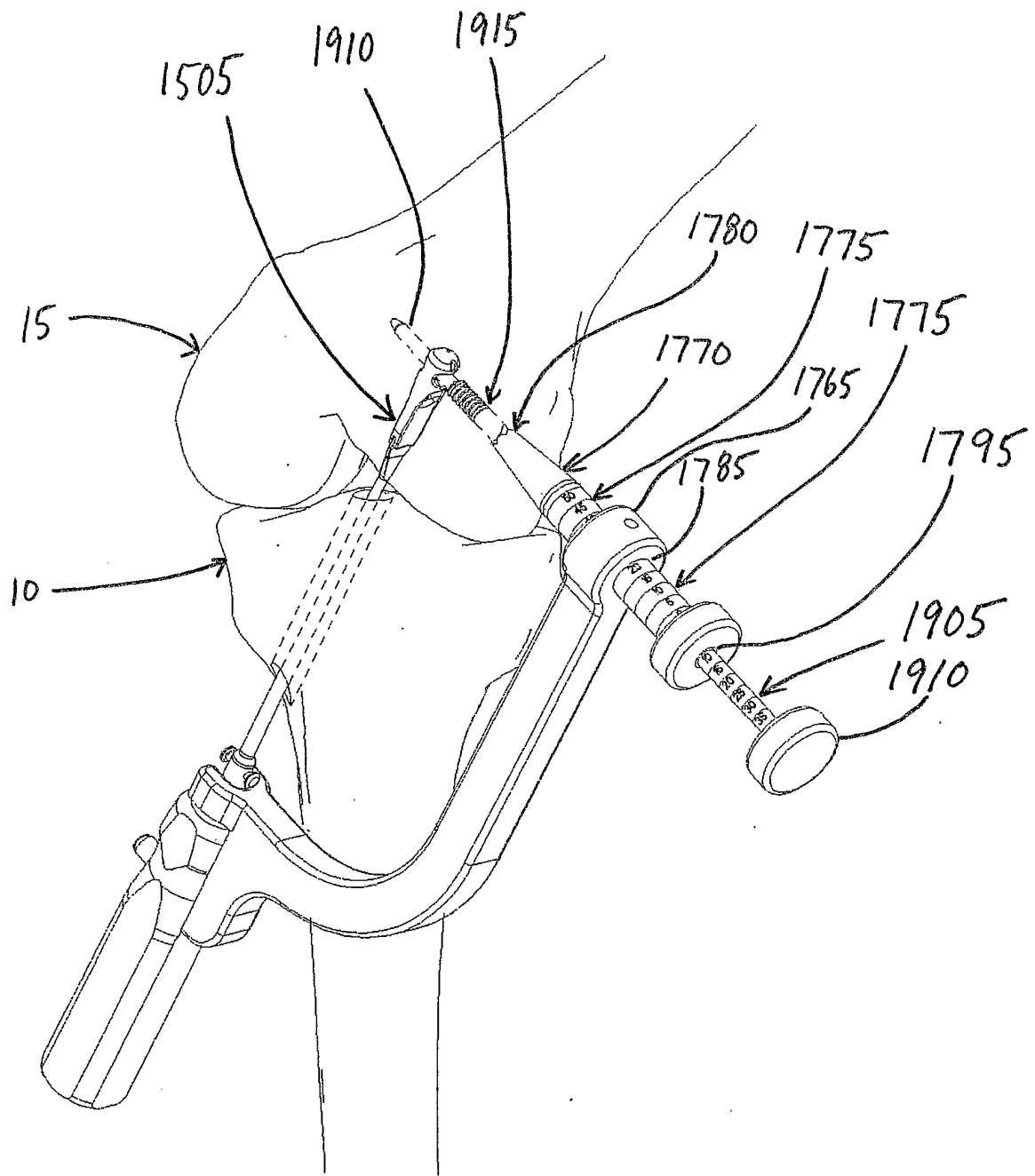

FIG. 56