

Nov. 11, 1947.

L. D. C. WOODYARD ET AL

2,430,751

HAIR DRIER

Original Filed Aug. 17, 1939

3 Sheets-Sheet 1

Fig. 1.

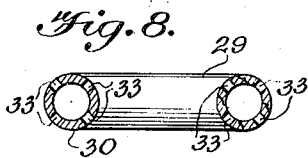
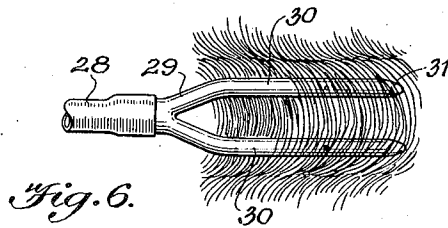
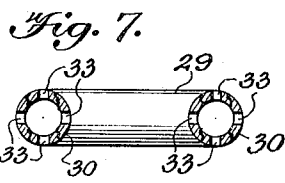
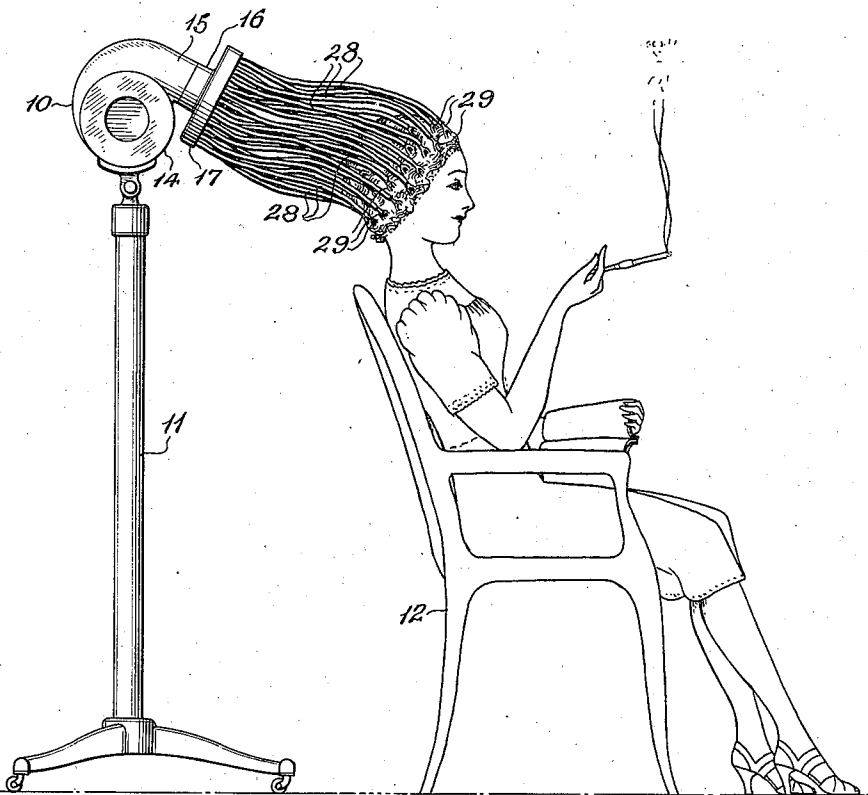

Inventors:  
John G. Kaefter, Jr.,  
Livia D. Charles Woodyard,  
Gerald P. Tyler,  
Horace Woodward  
Attorney

Nov. 11, 1947.

L. D. C. WOODYARD ET AL  
HAIR DRIER

2,430,751

Original Filed Aug. 17, 1939 3 Sheets-Sheet 2

Fig. 2.

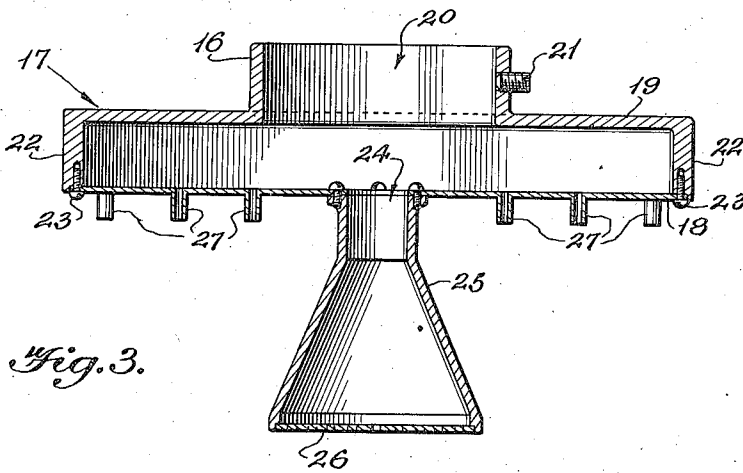
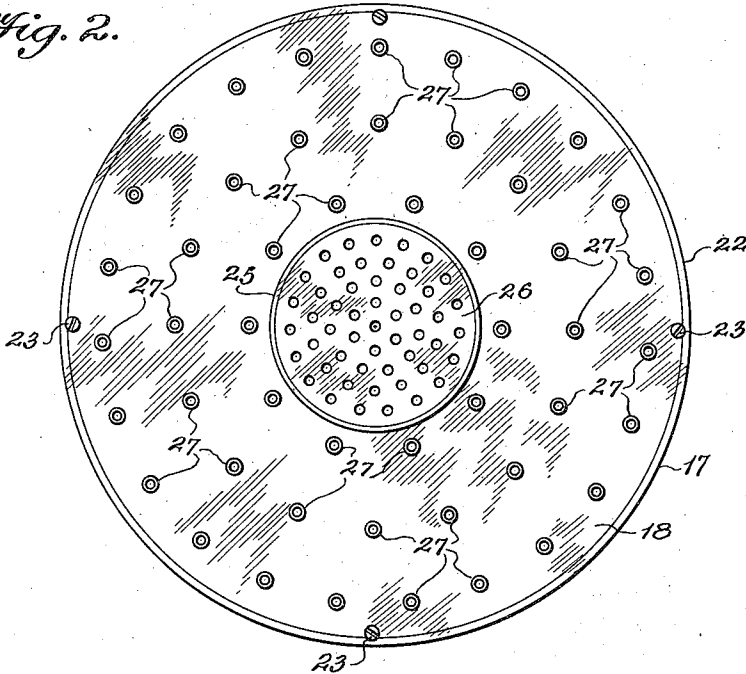

Fig. 3.

Inventors:  
John G. Kaefer, Jr.  
Livie D. Charles Woodyard,  
Gerald P. Tyler,  
By Horace Woodward,  
Attorney.

Nov. 11, 1947.

L. D. C. WOODYARD ET AL

2,430,751

HAIR DRIER

Original Filed Aug. 17, 1939

3 Sheets-Sheet 3

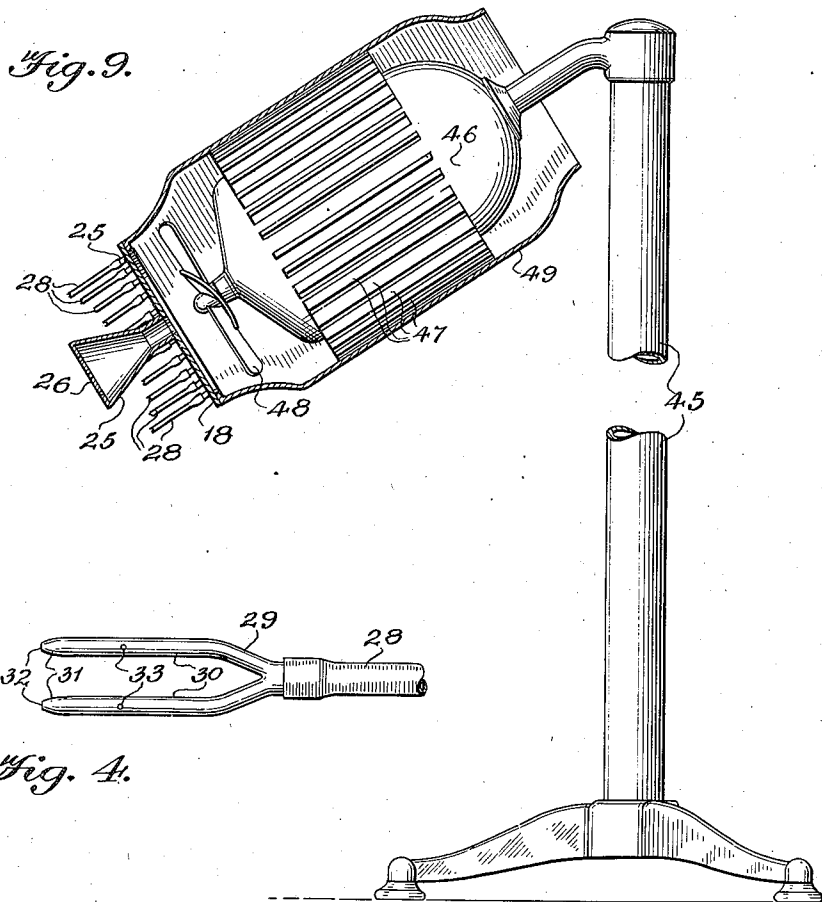

*Fig. 4.*

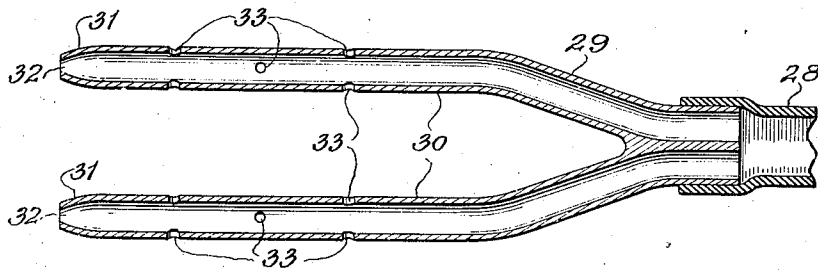

*Fig. 5.*

Inventors:  
*John G. Kaefel, Jr.,  
Lovie D. Charles Woodyard,  
Gerald P. Tyler,*  
By *Horace Woodward*  
Attorney

# UNITED STATES PATENT OFFICE

2,430,751

## HAIR DRIER

Livie D. Charles Woodyard, Dayton, Gerald P. Tyler, Cincinnati, and John G. Kaefer, Jr., Batavia, Ohio

Substituted for abandoned application Serial No. 290,684, August 17, 1939. This application March 12, 1946, Serial No. 653,762

2 Claims. (Cl. 34—97)

1

This application is a substitute for our abandoned application No. 290,684, filed August 17, 1939.

The device relates to devices for drying the hair of human beings, and particularly in connection with coiffures, and otherwise. It is an important object to present an appliance adapted to introduce air into the hair of a person while it is delicately laid or formed about the head so that it may be dried without disturbance of the good appearance of the coiffure. It is also an important aim to provide a means whereby the hair of a person may be completely dried in an exceptionally short time.

One of the most difficult drying problems of the hair dresser or "beauty specialist" of the present day is the drying of the hair of a person when dressed with a "finger wave." In this latter coiffure, it is necessary to have the hair very wet, and this is usually effected with an aqueous solution in which various materials are included, such as perfume, hair oils, and hair setting materials adapted to hold the hair in place, or to cause it to retain when dry the curled forms imparted while the hair was wet. Owing to the fact that the hair lies in very close and well ordered relation, somewhat "plastered" against the head, prior drying equipment has not been effective in materially shortening the time required for drying the hair, because the air currents have not been able to penetrate this closely arranged mass of hair, and while the extreme outer or surface portions of the coiffure have been dried, the portion just below the surface of the arranged hair and next the scalp have remained wet for long periods during treatment with hair driers of the prior art, thirty-five minutes to an hour and more being required to effect drying properly, while with our invention from ten to twenty minutes is sufficient.

At the same time, our invention involves less heating of the head of the patron, and effects the complete drying of the hair in much greater comfort generally. It is also less difficult to manage for the operator, and involves less risk of injury to the patron as well as the operator, since no heavy or bulky device has to be adjusted to the head of the patron, but only featherweight air nozzles, which may be inserted at will in the hair in accordance with the requirements for effective drying.

It is a novel feature of our invention that the drying nozzle elements are so constructed that they may be made light enough to be supported and retained by the hair itself, into which they

2

are inserted, without disordering the most delicate coiffure.

It is an important attainment of our invention that it is so constructed that no special mechanical or technical training in its use is required to enable operators to utilize it.

A desideratum of great weight is to perfect such an equipment that may be produced at a low cost, and operated with a minimum cost for maintenance and repair.

Additional objects, advantages and features of invention reside in the construction, arrangement and combination of parts involved in the embodiment of the invention, as will appear from the following description and accompanying drawings, wherein

Figure 1 is a general view of an installation of our equipment in use, as applied to the head of a person.

Figure 2 is a front view of the manifold chamber.

Figure 3 is a longitudinal section of the chamber.

Figure 4 is a full size elevation of one of the hair pin nozzles.

Figure 5 is an enlarged longitudinal section thereof in its major plane, showing the flexible duct tube applied thereto.

Figure 6 is a detail elevation of a portion of the head of a person whose hair has been set, showing one of our nozzles applied and supported in the person's hair.

Figure 7 is an enlarged cross section of a pin.

Figure 8 is a similar view of a modification.

Figure 9 is an elevation of a stand and showing in section a blower drier unit mounted on the stand.

There is illustrated in Figure 1 a typical installation, including our invention, although the equipment may be varied largely in design and construction. In the present instance there is shown a commercial form of centrifugal electrical air blower 10, of well known construction, mounted on a caster stand 11, of any desired construction readily rollable from place to place, on the floor of a room or other place, to bring it within convenient distance of the chair 12, which may also be of any common form suitable for such uses. In the chair a patron is shown, to whose head the invention is applied by an operator, although it may also be done by the persons upon whose head it is to be utilized.

In the present instance, the centrifugal blower has the usual circular casing portion 14 and tangential mouth 15 circular in cross section, and

having telescoped thereon a mounting sleeve 16 of a hollow circular manifold head 17. The latter consists of parallel front and back plates 18 and 19 respectively, the latter one being centrally apertured to form an air inlet opening 20 and having the sleeve 16 formed integrally on or united therewith around the air inlet. The sleeve may have one or more set screws 21 engaged therein to impinge against the cylindrical wall of the blower mouth so as to retain the head removably in place on the blower. The plate 19 has integrally formed thereon a peripheral flange or wall 22, interiorly rabbeted and having the plate 18 set in the rabbet and held by a suitable number of screws 23. The plate 18 is formed with a central opening 24 therethrough and mounted perpendicularly on the plate there is a large flared nozzle 25 having a stem communicating with this opening, the nozzle being covered by a flat foraminated plate 26 through which air is directed toward the head of the user. The remainder of the plate 18 is foraminated, and in the multiplicity of openings in this outer part there are set respective nipples 27 projecting a short distance from the plate and adapted to receive frictionally therearound the ends of respective flexible rubber or the like hose or tubes 28, in the outer ends of which there are similarly set respective individual combined hair pin-nozzle members 29 to be described.

While the proportions of the apparatus may be widely varied, in a typical unit, the sleeve 16 has an internal diameter of two and five-eighths inches, the central opening 24 is three-quarters of an inch in diameter; the outside diameter of the manifold 17 is seven and three-quarters inches; the space between the plates 18 and 19 is about three-quarters of an inch, while the nipples 27 are one-eighth inch inside and three-sixteenths of an inch outside diameter. The pin nozzles 29 are in the present instance formed of stock brass thin-wall tubing, one-eighth inch outside diameter. The pin nozzle consists of two parallel tines or point portions 30 each tapered to a moderate point 31 and having an aperture 32 coaxially in the point, while a suitable number of very small longitudinally spaced openings 33 are formed on several radii through the walls of the tines, there being six of these side openings on each tine in the present instance. Two sections of the brass tubing have been utilized to form the nozzle in the device illustrated, these being joined and united at their bases in close parallel relation with open inner ends inserted into the rubber tubing, their outer ends being offset in parallel relation and rectilinear, although the formation of the two tines may be otherwise effected. The manifold head 17 has a diametrical axis which is intended to extend in a vertical plane, although the head may be inclined forwardly at its upper part. It is important to note that the uppermost tubes 28 at the upper part of the head 17 are the longest, and those below are progressively shorter to an intermediate level, while those still further below may be of the same and uniform length, as those last mentioned, or may be progressively longer, if desired. The purpose of this is to enable the tubes to readily reach the forward upper part of the scalp of a user and the nearer parts of the head without an excessive amount of tubing, and also avoid impedances of air discharged from the nozzle 25.

The openings 33 in the tines may be variously spaced, but preferably at least two such openings are formed at the outer side of each tine opposite

its mate on the same nozzle while a minimum number are formed on axes normal to the major plane of the respective nozzle. This is to minimize projection of air directly outward from the head, and to cause it to be directed extensively through the body of the hair. As shown in Figure 9, the openings may be formed diagonally with respect to the major plane of the nozzle, so that air will be directed both toward the scalp of the user and outwardly and laterally from the nozzle within the body of hair thereover. As shown in Figures 5 and 7, two openings may be formed at the lateral outer sides of the tines, and one on the inside of each, while on the side next the scalp and the side outward from the scalp single openings may be formed, these being staggered, so that well separated areas of air movement are established within and under the hair, with a minimum of air projected directly outward from the head and tending to pass directly away from the hair with a minimum drying effect. The pin nozzles 29 may be formed of other metals or other material than metal, and may have more tines, if desired. The parts of the head 17 may be formed of metal or synthetic gums, or the like, and have been formed of aluminum and brass.

While we have shown the invention embodied so as to be attached to a centrifugal blower, it will be understood that this is illustrative only, and other forms of fans and blowers may be used, as, for instance, shown in Figure 9, where the stand 45 carries a motor 45' mounted fixedly thereon, no swivel mounting being required for our invention. This motor may be of the heating type where a series of longitudinal heat diffusing fins 47 are formed on the motor case. An impeller 48 of any approved design is fixed on the motor shaft at the lower end. The motor may be mounted on an inclined axis as shown, or otherwise as desired. Around the motor there is a light sheet metal cylindrical casing 49, fitted closely around the fins of the motor case, and extending slightly below the impeller, where it is suitably shaped to receive the plate 19 before described and the assembly of central large nozzle 25 and tubes 28, as before described.

It is an important advantage that there is no severe draft directed on or around the head of the patron and that the noise of the motor and fan are muffled and disagreeable noises accompanying operation of prior driers of the hood type eliminated. The patron is thus enabled to light a cigarette without difficulty and to smoke without the ash and sparks of burning tobacco being thrown upon the garments of the patron or otherwise caused to develop danger of fire.

The absence of noise enables the patron to carry on a conversation while his or her hair is being dried, which is another important advantage due to the particular construction presented. It will be understood that the tubes 28 absorb sound vibrations, and that the nozzles 25 act as a sound muffler, breaking up sound waves from the motor and fan or impeller blades most effectively. In the hood type of drier, the sound is focussed against the head and ears, and is a most annoying feature. It is a practice of some operators to provide ear mufflers for patrons to lessen the ill effects of the noise and heat, need for which is obviated by our invention.

In the use of our invention, the hair of the subject is treated and dressed in the same manner as heretofore customary where natural air currents were depended on to dry the hair, or where special driers were employed, no special

treatment or application of materials being required to enable our invention to function effectively.

Ordinarily, in the production of a "finger wave," which is the most difficult coiffure to dry, the hair is washed, and then, without drying, a viscous material known in the trade as a "wave set" or "wave lotion" is applied and worked into the hair thoroughly. Then, with fingers and comb, the hair is pressed tightly against the head while formed in sinuous or serpentine waves, the hair with its "set" material thus forming in effect a sheet in which the hairs are all laid substantially parallel in the same directions and held together by the "set" liquid. The head is completely enclosed by this mass of adhering hairs from the forehead to the nape of the neck. Both with our invention and under prior practice, operators find that to obtain the best results a very wet condition of the hair mass is requisite. While it is possible to use less liquid in certain cases, as a general rule, greater effectiveness in the coiffure dress is obtained when the hair is quite wet.

After the formation of the waves as above described, a fine net (not shown) is fitted closely over the head as is customary under prior methods to hold the waved hair in place while drying.

The subject being seated in a suitable chair, the stand carrying our air blower and drier unit is now brought to a position immediately behind the subject with the axis of the nozzle approximately coincident with the center of the subject's head, as may be understood. If the device is inclined as shown in Figure 9, the nozzle 25 is located slightly to the rear of the subject, and may be at a level only slightly above the head of the subject. But if the device is mounted on a vertical axis, it is desirable to have it at a greater elevation so that it will not interfere with the placement of the pins 29, as will be described.

Starting with the longer tubes 28, the pins at their ends are inserted under the hair and close to the scalp of the subject, the two tines 30 being laid almost flat against the head of the person. Actually the pins do not lie against the scalp directly, as the rounded points of the pins cause them to pass over a number of hairs, which support the pins away from contact with the scalp. The pins may be inserted without changing the set of the hair, as desired, and owing to the thinness of the pins the hair is not materially displaced from the lay imparted thereto by the beautician in the formation of the waves initially. By pressing the points of the pins laterally against the hair, the subjacent portion is depressed inwardly of the adjacent portion in advance thereof, and the latter springs outward, affording a path through which the pin may be moved longitudinally under the waved hair without disturbance thereof, so that the waved portion lies entirely without the tines 30. After the pins of the longest and forwardmost tubes 28 are placed, the pins of the next tubes are similarly placed, the pins being adjusted at properly spaced intervals to cause a good distribution of the air ejected through the pins, until all the pins have been placed, substantially as shown in Figure 1, although various arrangements of the pins may be practiced as individual discretion indicates. The order in which the pins are put in place may also be varied as the discretion of the operator indicates to be desirable.

It is important to understand that there is a substantial circulation of the ejected air from the pins close to or near the scalp under the hair,

so that it does not pass directly from under the hair to the exterior of the coiffure close to the points of the discharge from the apertures of the pins, but its passage outward perpendicularly to the head is retarded so that it moves laterally from the pins over a substantial area of the head and gradually percolates or transpires to the exterior. The air in this respect is able to effect penetration into masses of hair more effectively under the operation of our invention than where air currents are simply directed against the head from without, since in the latter case the air may be easily deflected, but in the application of our invention, it is under confinement and pressure between the scalp and the overlying hair and will force its way gently and effectively through the hair masses.

It should be noted that the use of the two or more tine nozzles in our pin element may be utilized to insure the definite direction of the air ejected from the openings in the tines so that it may be principally projected therefrom in a direction best adapted to cause it to move some distance between the major hair mass and the scalp before leaving the hair and not tend to pass directly outward through the hair and escape with a loss of efficiency in drying; and also so that it will not be directed directly against the scalp which might cause excessive heating of the head of the patron. For this reason, we prefer to form more of the openings 33 at the side of each tine facing away from the opposite tine of the same pin and approximately coincident with the plane of the two tines, than are formed on axes normal to or at considerable angles to that plane, as shown in Figures 4 and 5.

As shown in Figure 8, there may be a number of openings on axes diagonal to the plane, if desired.

In a complete set of nozzles, attached to the hoses, all of the nozzles may be of identical size and construction, so that no special coordination of sizes of the nozzles is required, and the expense for production correspondingly minimized as well as operations in the manipulation and use of our drier assemblage correspondingly, simplified.

By reason of the small size of the nozzle elements which do not exceed one and three-quarters inches in length, and the possibility of utilizing such a multiplicity of them, it is not necessary to curve the tines or points to fit the head, but as the tines are so short, the contours of the head are accommodated by placement of the devices at close intervals under the hair at numerous places throughout the area of the head. Due to the small size of the pin elements, also, when one is inserted, it does not extend far enough to lift the layered hair materially away from the head, so that the water or finger wave coiffure, as well as the water-laid permanent will not be disordered by the extremities of the pins pressing outward thereunder after insertion, or by passing through the layered hair from the under side.

While we have described particular embodiments of the invention, we do not regard it as limited thereto, and various changes in construction, and arrangement may be made without departing from the spirit of the invention as more particularly set forth in the appended claims, wherein we claim:

1. Hair drying means consisting of a manifold chamber, means to supply air thereto continuously, said chamber having a multiplicity of ported nipples, respective flexible ducts from the

7

nipples and respective small forked light-weight hollow foraminate terminal pin elements thereon, and a large nozzle projected centrally from said manifold chamber, constructed and arranged to project a substantial volume of air therefrom among said flexible ducts.

2. The structure of claim 1 including means to support said chamber with the axis of said large nozzle on an axis with a coiffure, said ducts being graduated on length whereby they may be extended to respective parts of the coiffure with a minimum tortuousness and a minimum diversion of air from said large nozzle.

LIVIE D. CHARLES WOODYARD.  
GERALD P. TYLER.  
JOHN G. KAEFER, JR.

REFERENCES CITED

The following references are of record in the file of this patent:

	Number
	771,468
	931,881
5	1,260,266
	1,372,237
	1,431,943
	1,514,495
10	1,809,038
	1,852,933
	1,899,352
	2,189,430
	2,224,876

15	Number
	406,924
	540,355
20	42,133

8

UNITED STATES PATENTS

Name	Date
Falk -----	Oct. 4, 1904
Marr -----	Aug. 24, 1909
Jacobs et al. -----	Mar. 19, 1918
Kraner -----	Mar. 22, 1921
Gee -----	Oct. 17, 1922
Wirth -----	Nov. 4, 1924
Hogrebe -----	June 9, 1931
Maier -----	Apr. 5, 1932
Peterson -----	Feb. 28, 1933
McClure -----	Feb. 6, 1940
Matys -----	Dec. 17, 1940

FOREIGN PATENTS

Country	Date
Great Britain -----	Mar. 8, 1934
Germany -----	Dec. 14, 1931
France -----	Mar. 7, 1933
(1st addition to No. 733,438)	