

T. L. JONES.
Steam Generators.

No. 199,648.

Patented Jan. 29, 1878.

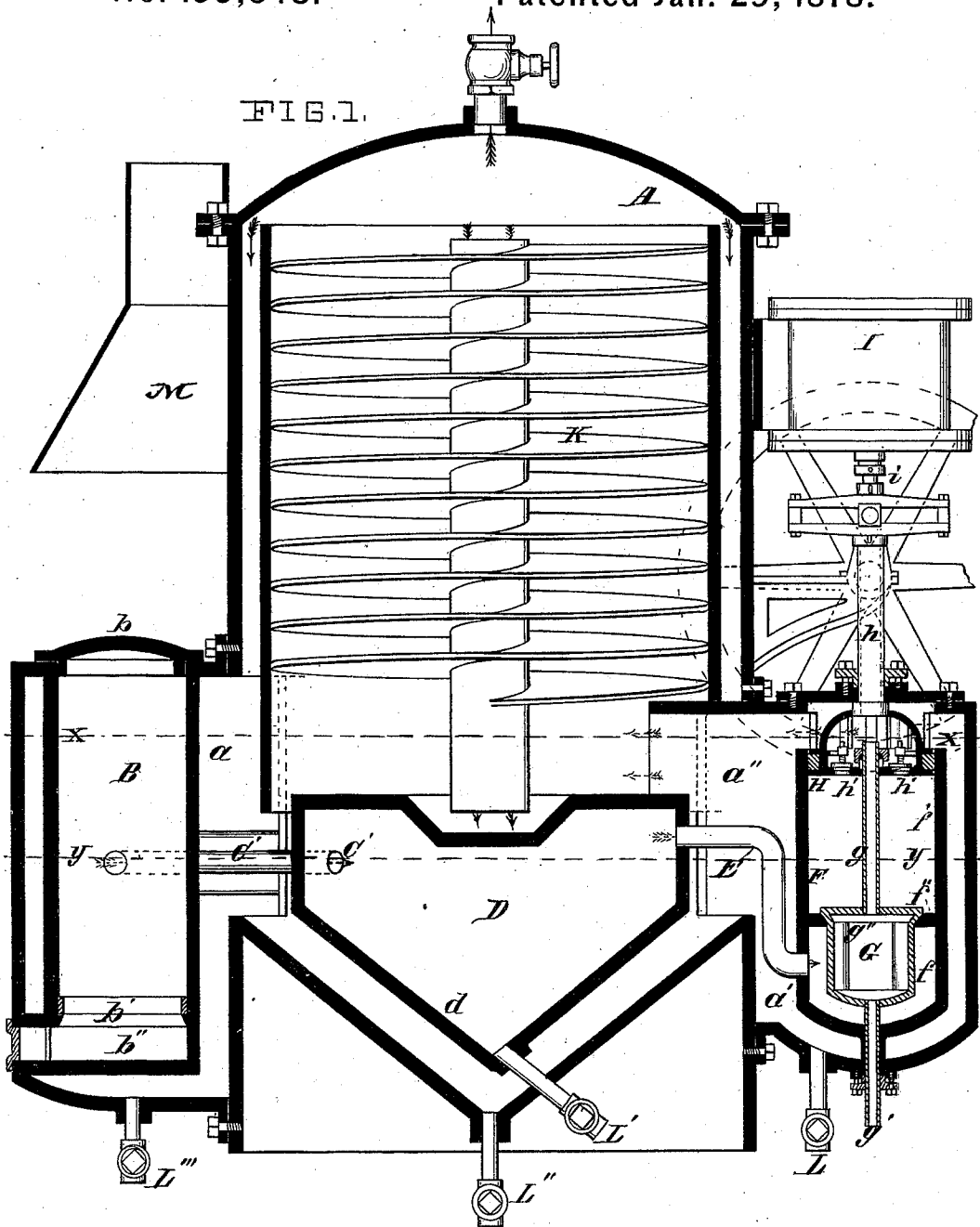

ATTEST.
Charles P. Pillsbury
Paul Bakewell

INVENTOR.
Thomas L. Jones,
by Chas. D. Moody,
his atty.

T. L. JONES.
Steam Generators.

No. 199,648.

Patented Jan. 29, 1878

FIG. 2.

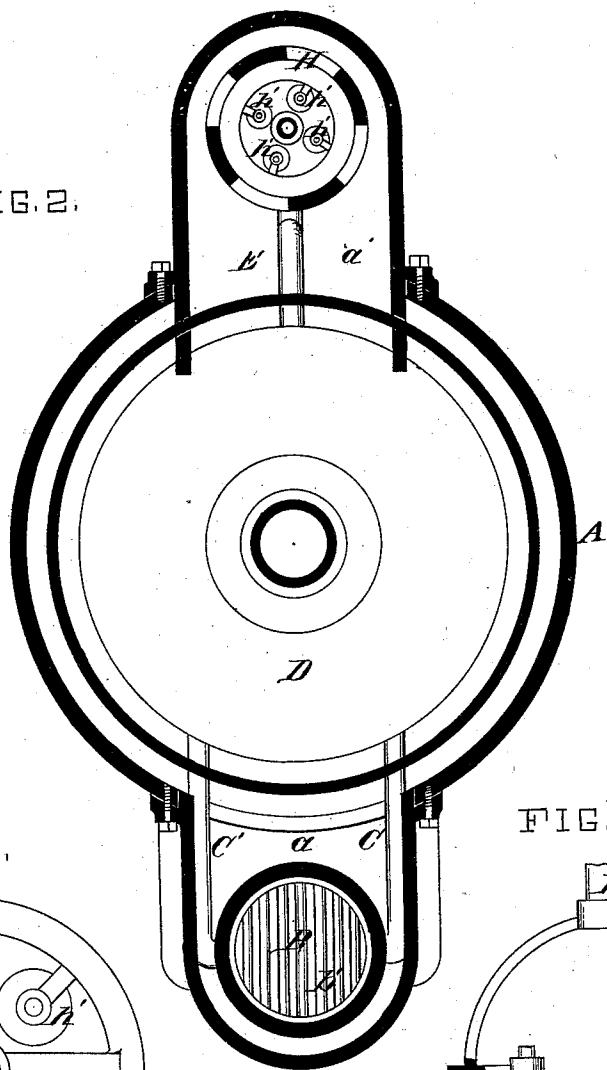
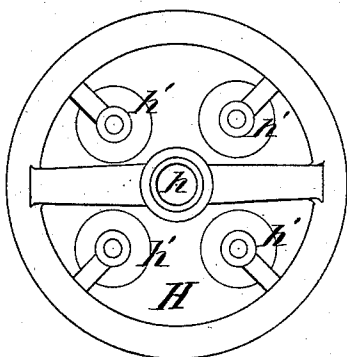

FIG. 3.



ATTEST.

Charles Pickles
Paul Bakewell

FIG. 4.

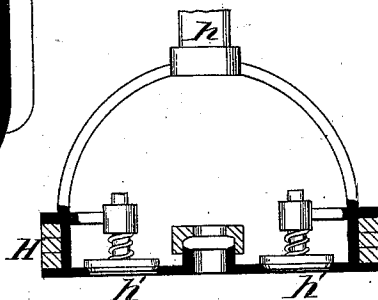

INVENTOR.

Thomas L. Jones.
by *Chas. D. Moody,*
his atty.

T. L. JONES.
Steam Generators.

No. 199,648.

Patented Jan. 29, 1878.

FIG. 5.

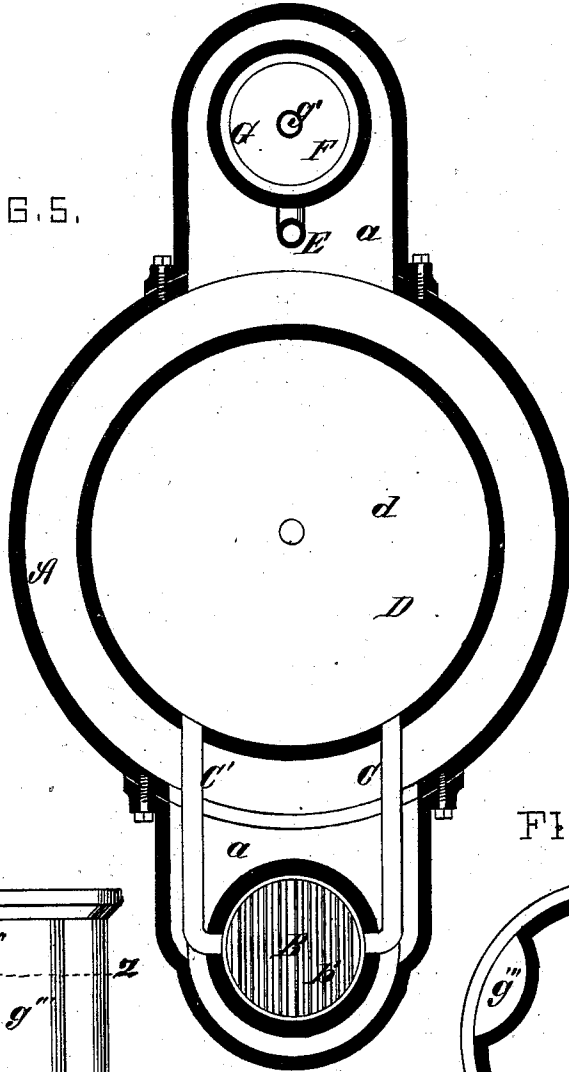

FIG. 6.

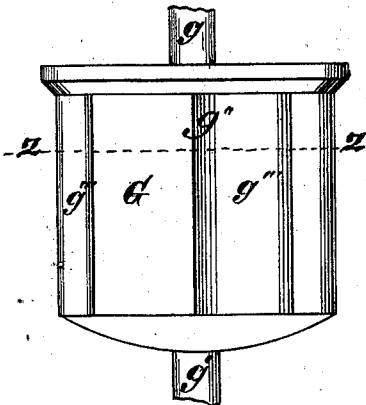
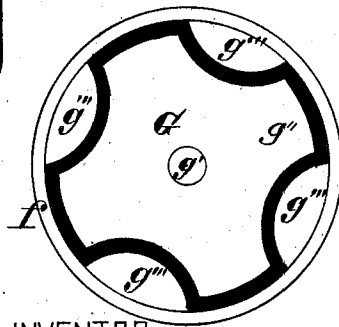

FIG. 7.



ATTEST,

Charles Peckles
Paul Baxevell

INVENTOR,

Thomas L. Jones.
by *Chas. D. Moody,*
his atty:

UNITED STATES PATENT OFFICE.

THOMAS L. JONES, OF NATCHEZ, MISSISSIPPI.

IMPROVEMENT IN STEAM-GENERATORS.

Specification forming part of Letters Patent No. **199,648**, dated January 29, 1878; application filed March 21, 1877.

To all whom it may concern:

Be it known that I, THOMAS L. JONES, a resident of Natchez, Mississippi, have made new and useful Improvements in Steam-Generators, of which the following is a full, clear, and exact description, reference being had to the annexed drawing, making part of this specification, in which—

Figure 1 is a sectional elevation of a generator embodying my improvements; Fig. 2, a horizontal section taken on the line *x x* of Fig. 1; Fig. 3, a plan of the plunger used in injecting the heated gaseous currents into the generator; Fig. 4, a sectional elevation of the latter; Fig. 5, a horizontal section taken on the line *y y* of Fig. 1; Fig. 6, an elevation of the hot-air valve; and Fig. 7, a horizontal section of the latter, taken on the line *z z* of Fig. 6.

Similar letters denote similar parts.

I have heretofore made an improvement in steam-generators wherein the steam is generated by forcing a heated air-current, together with the products of combustion of the fire used in heating the air-current, directly into and through the water in the generator.

In the construction referred to, the heating agency is between the air-injecting mechanism and the water of the generator—that is, the air is forced into and through the furnace, and thence, together with the products of combustion, into the water of the generator. This arrangement necessitates a uniform pressure throughout the construction, the pressure in the air-pump and furnace-chamber being the same as the steam-pressure within the generator.

In the present construction the injecting mechanism is located directly within the body of water contained in the generator, but is arranged to draw the air into and through the heating-furnace, and then to force it, together with the products of combustion, into the water of the generator. As thus arranged the fire is always accessible, for, whatever steam-pressure there may be within the generator proper, only atmospheric pressure exists in the furnace-chamber. At the same time the air-injecting mechanism, from being surrounded by water, does not heat to such an

extent as to interfere with the action of its working parts.

In the annexed drawing, A represents a steam-generator containing my improvements. It may be of any desirable shape and proportions consistent with the features peculiar to the present application. It is, preferably, of the upright cylindrical form, as shown.

B represents the furnace-chamber. It is arranged, preferably, at the side of the main portion of the generator in an extension, *a*, thereof, and so as to be surrounded with water. It is open both above and beneath to the open air, and is provided with a removable cover, *b*, grate *b'*, and ash-pit *b''*.

Tubes C C' lead from the furnace-chamber, and preferably from a point between the top and bottom of the fire therein, into what I term a "settling-chamber," D, that is arranged in the water-space of the generator, and, preferably, in the lower part thereof, as shown.

The chamber, by preference, has a tapering bottom, *d*. From this settling-chamber a passage or passages, in the form of the tube E, lead to the lower compartment *f* of a valve-chamber, F, that is also contained in the water-space of the generator, and, preferably, in an extension, *a'*, thereof.

The valve-chamber has an upper, *f'*, and lower, *f*, compartment, separated by the seat *f''*, in which what I term the "hot air-valve" G works, and that serves to open and close the passage from the compartment *f* to the compartment *f'*, as hereinafter described.

H represents a plunger that works up and down in the compartment *f'*, its operation being effected, preferably, by means of an auxiliary engine, I, whose piston-rod *i* connects with the stem *h* of the plunger. In the latter, and seating downward, are several valves, *h' h' h'*, that serve to open and close communication between the compartment *f'* of the valve-chamber and the main water-space *a''* of the generator.

The operation of the invention, as thus far described, is as follows: By means of the engine I the plunger is drawn, say, upward in the valve-chamber F. This movement closes the valves *h' h'*, and tends to form a

vacuum beneath the plunger. This induces an air-current into the furnace B, where it is heated, and thence, together with the products of combustion, through the tubes C C' into the settling-chamber D, where the solid particles leaving the furnace-chamber have opportunity to settle. The heated currents thence pass by way of the passage E to the lower compartment *f* of the valve-chamber, and thence past the valve G into the upper compartment *f'*, the upward movement of the plunger causing, by suction, the valve G to lift slightly from its seat *f''* and admit the heated currents to the compartment *f'*. The plunger is now, on its return-stroke, moved downward in the chamber *f'*, which movement at once closes the valve G in its seat *f''*, and opens the valves *h' h'* in the plunger. The heated gaseous currents are then forced past the valves *h' h'* into the water-space of the generator, and thence escaping upward into and through the screw K to the upper part of the generator, as described in the improvement above referred to. The plunger H is again drawn upward, causing an additional amount of heated air and gas to pass into the valve-chamber F, and thence, on the downward movement of the plunger, forced into the generator, and so on.

By duplicating the valve-chamber and parts immediately therewith connected, the flow of the gaseous currents from the furnace into the generator is made continuous.

It is important that every part of the generator that is exposed to the heated gaseous current be kept from overheating. I accomplish this by arranging all such parts so that water comes in contact with one side thereof. The hot-air valve G is accordingly made hollow, and is provided with a hollow stem, *g*, that opens at its upper end into the water-space of the generator. It can also open below, at its lower end *g'*, into the water-space of the generator; but I preferably extend this part of the stem through the outer wall or bottom of the generator, and utilize it as an inlet for the feed-water of the generator. The feed-water is thus brought immediately in contact with that portion of the mechanism which is the most likely to be injured by the heat.

Any suitable connection that provides for the slight movement of the valve-stem can be made with its lower end *g'*, and the water, after entering the stem and valve G, passes upward through the upper part *g* of the stem into the generator.

The stem works in suitable stuffing-boxes, both above in the plunger H and below in the valve-chamber and casing of the generator.

Suitable blow-off cocks L L' L'' L''' are attached to the various parts of the construction.

The preferable form of the hot-air valve G is shown more distinctly in Figs. 6 and 7. It is made comparatively large to admit a suf-

ficient amount of water, and to enable the heated gaseous currents to readily pass with but a slight movement of the valve. The body *g''* of the valve is made of a re-entering form, as shown at *g''' g''' g''' g'''*.

A special advantage accrues from the arrangement of the pipes C C', so as to provide an exit from the furnace-chamber at the side thereof.

The top and bottom of the furnace can be opened to the surrounding atmosphere without interfering with the operation of the invention.

If the exit were at the bottom of the furnace, the ash-pit could not be opened without admitting cold air to the generator, and for a similar reason the cover of the furnace could not be removed if the exit were at the top of the furnace. But when the exit is at a point between the top and bottom of the fire, the latter can be replenished and the ashes removed at will, for the air, whether entering the furnace through its top or bottom, must pass through a portion of the fire before entering the escape-pipe. The most desirable level for the latter I have ascertained to be a little below the center of the furnace, as this provides for the replenishment of the fire.

The amount of air entering the furnace can be suitably graduated, and the fire can be perfectly controlled by suitably admitting the air from above or beneath, as occasion may require.

I do not desire to be confined to any special number of exit-pipes C C'. One or more can be used, as desired. This advantage, however, arises from the use of two exits arranged opposite each other, as shown. The air is drawn more evenly through the fire.

The exit-pipes C C' can, if preferred, pass directly to the valve-chamber F.

A further advantage arises from the above-described arrangement of the furnace, air-pump, and generator, and from drawing the air through the fire. The air has a better opportunity for becoming heated in the furnace than if it were forced through the latter, and the amount of air used in proportion to the products of combustion escaping from the furnace is less. The proper amount of air can also be more accurately admitted to the furnace.

M represents a chimney to receive the smoke from the furnace B when the generator is not in operation.

I claim—

1. The combination of the generator A, furnace B, pipes C, C', and E, settling-chamber D, and valve-chamber F, substantially as described.

2. In a steam-generator wherein the steam is generated by passing heated air or gaseous currents directly into and through the water in the generator, the arrangement, substantially as herein described, of the air and gas injecting mechanism within the body of water

of the generator, and between the furnace or heating agency and the point where the heated gaseous currents are injected into the generator.

3. The combination of the generator A, valve-chamber F, pipe E, valve G, and plunger H, having the valves *h' h'*, substantially as described.

4. The combination of the plunger H, hollow valve G, and stem *g g'*, chamber F, and generator A, arranged substantially as described.

THOS. L. JONES.

Witnesses:

CHAS. D. MOODY,
SAML. S. BOYD.