

(19) World Intellectual Property Organization
International Bureau



(43) International Publication Date
21 October 2010 (21.10.2010)

(10) International Publication Number
WO 2010/118509 A1

(51) International Patent Classification:
F03D 3/04 (2006.01) *F03D 7/06* (2006.01)
F03D 3/06 (2006.01)

(21) International Application Number:
PCT/CA2010/000528

(22) International Filing Date:
8 April 2010 (08.04.2010)

(25) Filing Language: English

(26) Publication Language: English

(30) Priority Data:
61/168,993 14 April 2009 (14.04.2009) US
61/286,434 15 December 2009 (15.12.2009) US

(72) Inventor; and

(71) Applicant : QUINTAL, Réjean [CA/CA]; 33, rue
Landry, St-Jean-sur-Richelieu, Québec J4X 4V4 (CA).

(74) Agent: OGILVY RENAULT LLP / S.E.N.C.R.L.,
s.r.l.; Suite 2500, 1 Place Ville Marie, Montréal, Québec
H3B 1R1 (CA).

AO, AT, AU, AZ, BA, BB, BG, BH, BR, BW, BY, BZ, CA, CH, CL, CN, CO, CR, CU, CZ, DE, DK, DM, DO, DZ, EC, EE, EG, ES, FI, GB, GD, GE, GH, GM, GT, HN, HR, HU, ID, IL, IN, IS, JP, KE, KG, KM, KN, KP, KR, KZ, LA, LC, LK, LR, LS, LT, LU, LY, MA, MD, ME, MG, MK, MN, MW, MX, MY, MZ, NA, NG, NI, NO, NZ, OM, PE, PG, PH, PL, PT, RO, RS, RU, SC, SD, SE, SG, SK, SL, SM, ST, SV, SY, TH, TJ, TM, TN, TR, TT, TZ, UA, UG, US, UZ, VC, VN, ZA, ZM, ZW.

(84) Designated States (unless otherwise indicated, for every kind of regional protection available): ARIPO (BW, GH, GM, KE, LR, LS, MW, MZ, NA, SD, SL, SZ, TZ, UG, ZM, ZW), Eurasian (AM, AZ, BY, KG, KZ, MD, RU, TJ, TM), European (AT, BE, BG, CH, CY, CZ, DE, DK, EE, ES, FI, FR, GB, GR, HR, HU, IE, IS, IT, LT, LU, LV, MC, MK, MT, NL, NO, PL, PT, RO, SE, SI, SK, SM, TR), OAPI (BF, BJ, CF, CG, CI, CM, GA, GN, GQ, GW, ML, MR, NE, SN, TD, TG).

Published:
— with international search report (Art. 21(3))

(81) Designated States (unless otherwise indicated, for every kind of national protection available): AE, AG, AL, AM,

(54) Title: HORIZONTAL WIND POWERED TURBINE

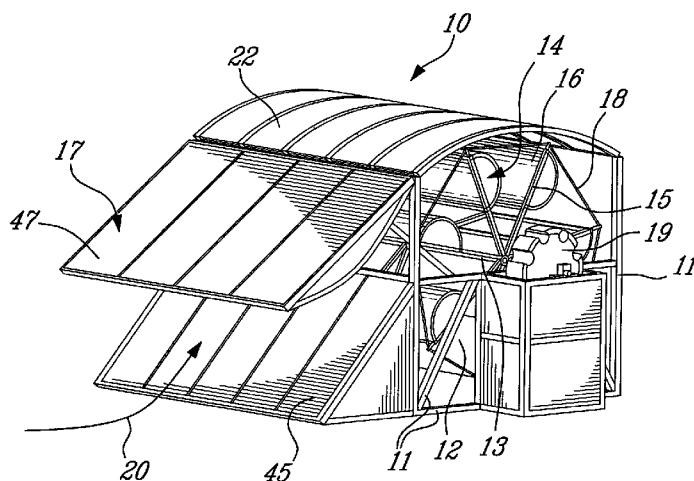

Fig-1A

(57) Abstract: A wind powered turbine is comprised of a frame on which is horizontally and rotatably supported a rotor on a rotor shaft. The rotor is formed by three or more radial blade members which are secured to the rotor shaft. The radial blade members are equidistantly spaced from one another and each have support arms and a wind vane secured at an outer end portion of the support arms. The wind vane is shaped to capture an airflow directed thereagainst for displacement thereof to create a rotational force about the rotor shaft to rotate the shaft about its longitudinal central axis. The radial blade members are rigidly interconnected to one another at an outer end portion thereof by tension adjustable bracing tie wires. A wind channeling guide assembly accelerates and directs the airflow in an actuating airflow path to impinge upon at least of the wind vanes positioned in the actuating airflow path.

WO 2010/118509 A1

- 1 -

HORIZONTAL WIND POWERED TURBINE

TECHNICAL FIELD

The present invention relates to a lightweight
5 horizontal wind powered turbine for generating power.

BACKGROUND ART

High cost of energy and the depletion of natural
resources has led to the increasing development of
10 environmentally safe and inexpensive alternative energy
sources. The present invention concerns the use of the
wind energy to develop electrical energy and specifically
to wind powered turbines. Wind powered turbines have been
in existence for many years but these are usually very
15 costly to produce and often are not operational at very
low wind speeds namely below 5 km/h. Some of these wind
turbines are also massive structures which are unsightly
and therefore are usually located in remote areas with the
electricity produced being conducted by overhead or
20 underground cables to distribution transformers. These
large wind turbine structures are also expensive to
install, requiring heavy equipment and a skilled
workforce. Before the installation of such turbines it is
also necessary to obtain environment impact studies and
25 approval by regional governing bodies which demands public
consultations. These large wind turbines are vertically
mounted turbines and are not pleasing to the eye and not
suitable to adapt to produce electricity for a single
industrial or residential building. However, horizontal
30 wind turbines have proven more pleasing to the eye but
again the constructions thereof are often unsightly and
they are often too costly and heavy for mounting on roofs
of building structures. Typical examples of wind powered
horizontal turbines are disclosed in U.S. Patent Nos.

- 2 -

6,981,839 and 7,540,705 and British Patent GB 2,185,786. The wind turbines disclosed by these patents all have certain constraints such as not being able to operate at low wind speeds, they are heavy and noisy, require
5 extensive maintenance and are not aesthetically pleasing when mounted on the roof tops of buildings.

DISCLOSURE OF INVENTION

It is a feature of the present invention to
10 provide a horizontal wind powered turbine which substantially obviates the above-mentioned disadvantages of existing horizontal wind turbines.

A further feature of the present invention is to provide a horizontal wind powered turbine wherein the
15 rotor is constructed in a unique fashion to make it very lightweight and capable of operating at very low wind speeds.

Another feature of the present invention is to provide a horizontal wind powered turbine which may
20 operate in a uni-directional or bi-directional state without displacing the turbine.

Another feature of the present invention is to provide a horizontal wind powered turbine which is easy to install and does not require skilled personnel for its
25 installation and servicing.

Another feature of the present invention is to provide a horizontal wind powered turbine which can be automatically controlled by a programmed controller module.

30 Another feature of the present invention is to provide a horizontal wind powered turbine which may be coupled in series and which series can be disposed in an assembly of back-to-back spaced series connected turbines.

- 3 -

Another feature of the present invention is to provide a horizontal wind powered turbine having an air inlet channeling structure provided with an adjustable gate defining a shape to impart a venturi effect to the airflow entering the turbine.

According to the above features, from a broad aspect, the present invention provides a horizontal wind powered turbine comprised of a frame on which is horizontally and rotatably supported a rotor on a rotor shaft. The rotor is formed by three or more radial blade members secured to the rotor shaft by securement means. The radial blade members are equidistantly spaced from one another. Each radial blade member has support arms and a wind vane secured to an outer end portion of the support arms. The wind vane is shaped to capture an airflow directed thereagainst for displacement thereof to create a rotational force about the rotor shaft to rotate the rotor shaft about a longitudinal central axis thereof. The radial blade members are rigidly interconnected to one another at an outer end portion thereof by tension adjustable bracing means. Wind channeling guide means are provided to accelerate and direct the airflow in an actuating airflow path to impinge upon at least one of the wind vanes positioned in the actuating airflow path to displace the wind vane by wind drag.

BRIEF DESCRIPTION OF THE DRAWINGS

A preferred embodiment of the present invention will now be described with reference to the accompanying drawings in which:

FIG. 1A is a simplified perspective view showing the construction of the horizontal wind powered turbine of the present invention;

- 4 -

FIG. 1B is a perspective view similar to Figure 1A but showing the turbine housing in a closed condition wherein the air inlet channeling structure is closed;

FIG. 2 is a perspective view of the turbine support frame with the rotor removed showing the construction of the frame and the air inlet channeling structure disposed in an open condition and illustrating the adjustable mechanism of the adjustable venturi gate;

FIG. 3 is a perspective view showing the rotor in an assembled condition;

FIG. 4A is a perspective view showing the construction of the radial blade members;

FIG. 4B is a perspective view of another embodiment of the construction of a radial blade;

FIG. 5 is a perspective view illustrating the construction of the shaft connecting assembly secured to the rotor shaft and to which the support arms of the radial blade members are retained;

FIG. 6A is a perspective view showing the construction of the adjustable wire connector;

FIG. 6B is a top view showing the loop end of a tie-wire disposed about the wire attaching sleeve and superimposed with the loop end of an adjacent wire;

FIG. 7 is a perspective view showing the construction of the guide ramp wall formed with vertical guide ribs;

FIG. 8A is a perspective view of the horizontal wind powered turbine of the present invention when connected side-by-side with a like horizontal wind powered turbine;

FIG. 8B is a cross-sectional view showing an example of the interconnection of the rotor shafts of the serially connected turbines of Figure 8A;

- 5 -

FIG. 8C is a simplified schematic view showing two series of wind powered turbines of the present invention disposed on a surface in a back-to-back spaced arrangement;

5 FIG. 9 is a simplified side view showing the wind powered turbine of the present invention provided with top and bottom outlet gates provided at the outlet of the wind powered turbine housing whereby the turbine can be operated in a bi-directional mode that is to say from
10 the back or the rear of the turbine;

FIG. 10 is a simplified block diagram showing the wind turbine of the present invention coupled to an electric network infrastructure and incorporating a system controller to operate the turbine and the regenerative
15 drive; and

FIG. 11 is an illustration of a building having a plurality of serially connected horizontal wind powered turbines constructed in accordance with the present invention and mounted on the roof structure of the
20 building.

MODES FOR CARRYING OUT THE INVENTION

Referring now to the drawings and more particularly to Figures 1A and 1B, there is shown
25 generally at 10 an embodiment of the wind powered turbine of the present invention. The turbine 10 comprises a frame 11 on which is horizontally and rotatably supported a rotor assembly generally at 12 on a rotor shaft 13. The rotor shaft 13 is supported on standard bearings, not
30 shown. The rotor assembly 12 is formed by three or more radial blade members 14 secured to the rotor shaft 13 by securement means as will be described later.

As hereinshown there are seven radial blade members 14 which are equidistantly spaced from one another

- 6 -

about the rotor shaft 13. Each radial blade member 14 has support arms 15 and a wind vane 16 secured to an outer end portion of the support arms 15. The wind vane 16 is shaped to capture an airflow 20, as shown in Figure 8C, directed thereagainst for displacement thereof to create a rotational force about the rotor shaft 13 whereby to rotate the rotor shaft about a longitudinal central axis thereof. The rotor shaft 13 is connected to the drive shaft of an electric motor 19 coupled thereto by conventional means, well known in the art. The support arms 15 and wind vane are constructed from aluminum for lightweight.

The radial blade members 14 are rigidly interconnected to one another at an outer end portion thereof by tension adjustable bracing tie-wires 18 which constitute an adjustable bracing means. These tie-wires are steel wires and their adjustability provide for a rotor structure which is very lightweight and strong, providing for a lightweight rotor shaft thereby greatly reducing the weight of the rotor shaft and the assembly 14 and permitting the rotor to be actuated or displaced at very low wind speeds below 5 km/h. The tie-wires 18 may be constructed of other suitable material including composite materials.

The wind powered turbine of the present invention also has an air inlet channeling structure 17 to accelerate and direct the incoming airflow, herein represented by arrow 20, in an actuating airflow path 21 (see Figure 8C) directed in an upper portion of the housing adjacent a convexly curved top wall 22. The radial blade members 14 extend into this accelerating airflow path 22 and spaced from the top wall 22 whereby the airflow impinges upon the vanes disposed in this actuating airflow path to displace the wind vane and

- 7 -

causes its displacement by wind drag. The inlet can capture wind in a radius of about 140° . As shown in Figure 8C, this airflow path exits in the rear end 23 of the wind powered turbine. The air is caused to enter the turbine housing at an angle of between 30° and 50° . This increases wind speed and reduces drag on the returning vanes 16.

As shown in Figure 1B, the frame may be provided with side walls 22' and have rear gates, as shown in Figure 9, to form a complete shelter to protect the turbine from difficult weather conditions such as snow, hail, heavy rain and heavy high winds. The shelter is not essential for the functionality of the turbine but provides better performance.

As shown in Figure 4A, the wind vane 16 is of semi-circular cross-section. Another alternative shape is illustrated in Figure 4B wherein the wind vane 16" has a semi-elliptical shape. The wind vanes are also secured between at least two support arms 15. One or more intermediate support arms 15' may also be provided if the wind vane is longer, thereby requiring additional support. The wind vane 16 thereby defines a curved inner wall 26. It also has transverse end walls 27 which are wind captivating end walls when the wind is at an angle. Intermediate wind captivating walls 27' may be provided if additional support arms, such as support arm 15', are provided. These transverse end walls 27 and intermediate wall 27' are secured behind the support arms 15 and 15', respectively.

With reference now to Figure 5, there is shown a securement means for securing the radial blade members 14 to the rotor shaft 13. As hereinshown, this securement means is comprised by a shaft connecting assembly 35 there being of course two of such assemblies to connect wind

- 8 -

vanes having two support arms 15. The shaft connecting assembly 35 has three or more rigid hollow posts 36, herein seven rigid posts 36 to accommodate the wind vanes 16 of the embodiment illustrated in Figure 1A and these 5 rigid posts 36 are immovably secured to a hub 37 and a metal disc 41 which is adapted for securement to the rotor shaft in a spaced-apart relationship. The rigid posts 36 are hollow metal posts having an open top end 38 to receive therein a bottom end portion 15" of the support 10 arms 15. The support arms 15 are aluminum rods and have a cross-section for close sliding fit engagement in the open ends of respective ones of the hollow tubular posts 36. Arresting means in the form of lock screws 39 immovably secures the solid rods in the hollow tubular post, prior 15 to tensioning the tie-wires 18. Spring biasing means, in the form of coil springs 40, are held captive in the bottom of the hollow tubular rigid post 36 and the support arms 15 sit on these and the lock screws 39 are set to retain the arms 15 in the hollow posts 36 during initial 20 tensioning of the tie-wires 18.

With reference now to Figures 6 and 6B, there will be described the tension adjustable bracing means which, as above-described, is comprised by tie-wires 18. These wires 18 are of equal lengths and are secured to an 25 adjustable wire connector 25 secured to the top end of the support arms 15 of the radial blade members. The adjustable wire connector 25 is an adjustable bolt 28 having a threaded shaft portion 29 threadably connected in the free outer end of the support arms 15 whereby to 30 adjust the length of the bolt above the vanes. A wire attaching sleeve 30, having opposed end flanges 30', is supported about a top end of the adjustment bolt 28 and captively receives therein an end attaching loop 18' of the tie wires 18, as shown in Figure 6B. the bolt

- 9 -

connector 25 has an engageable outer head 31 to impart rotation of the bolt 28 into the top end of the support arms 15 to adjust the outward displacement of the wire attaching sleeve whereby to apply tension on the tie-wires secured about the sleeve and extending in opposite directions. By displacing the adjustable bolt axially, the wire attaching sleeve is displaced to increase or decrease tension in the opposed tie-wires 18 as illustrated in Figure 6B. The tie-wires 18 are tensioned while the support posts are held secured at their lower ends in the rigid hollow posts with the bottom end of the posts resting on their coil springs 40. This provided for construction of a rigid balanced brace about the radial blade members 14. Thus, a lightweight frame structure consisting of rigidly interconnected radial blade members in spaced relationship is obtained and strengthening the radial blade member assembly about the rotor shaft. The lock nuts 32 are then loosened with the lower end of the support posts resting on their springs 40. The purpose of the springs is to permit absorption of the expansion in the metabolic support arms 15 due to temperature fluctuations. This prevents distortion in the support arms if they were to be immovably secured to shaft connecting assembly 35.

It is also pointed out that the wire attachment sleeve 30 can be made displaceable about a stationary post or the bolt 28 to provide this adjustment. By displacing the nuts 31 and 32 along the threaded shaft, which is now stationary, the sleeve position is made adjustable. Both these adjustable wire connectors have been found to be very effective, precise and an economical adjustable mechanism.

The tie-wires interconnected together about the outer circumference of the rotor assembly maintain the

- 10 -

support arms captive in the hollow tubular posts 36 of the shaft connecting assembly 35, shown in Figure 5. The rigid post and hub structure are welded on the flat steel disc 41 to maintain the rigid posts in a solid structure as the torque created by the wind vanes 13 is transmitted into the shaft through the connecting assembly 35 which drives the rotor shaft 13. The diameter of the rotor is made to suit the application of the use of the turbine and by increasing the diameter thereof the energy produced can be greatly increased. For example, doubling the diameter will result in a five times increment in the energy produced.

Referring now to Figures 1A, 1B, 2 and 7 to 9, there will be described the construction and operation of the channeling guide means constituted by the air inlet channeling structure 17, as shown in Figure 1A. This structure is comprised of an inclined guide ramp wall 45 which is secured below an air inlet end of the frame 11, and an adjustable venturi gate 47 hingedly connected to the frame 11 at a top end 46' of the air inlet end or air inlet opening 46. The guide ramp wall is angulated between 30° and 50°. The adjustable venturi gate 47 has an inner wall surface 48 which defines a convex curvature to impart a venturi effect in the region 20' (see Figure 8C) of the inlet airflow 20 whereby to accelerate the airflow 20 to create the actuating airflow path 21 inside the wind powered turbine. The arced roof 22 follows the wind turbine arc and limits the turbulence created by the housing and/or frame. The arc roof 22 also adds rigidity to the frame structure 1 and facilitates cleaning of the roof of snow and channels rain water outwards. It also provides an aerodynamic shape for the wind flow.

The adjustable venturi gate 47 is pressure biased in an open position by a pair of shocks 49 and a

- 11 -

wire and pulley mechanism 50 comprised of wire 51 and guide pulleys 52 and motor 53 displace the adjustable venturi gate against the biasing force of the pistons 49' to set the proper distance between the inner venturi surface 48 of the gate and the top surface 45' of the inclined guide ramp. This biasing arrangement obviates the use of a hydraulic system which is costly and troublesome. As shown in Figure 1B, the adjustable venturi gate is displaced to a closed position wherein the gate 47 abuts against the inclined guide ramp wall 45 whereby to substantially obstruct the air inlet end. This may be desirable under very high wind conditions or in conditions where the turbine is not utilized. Of course, other means may be provided to constitute a gate displacement means and a pressure exerting means to maintain the adjustable venturi gate at a desired position. For example, slotted guide rods may be pivotally connected at one end to the frame and at another end to the adjustable venturi gate with lock bolts extending in the slot to rigidly secure the adjustable venturi gate at a desired angle.

As shown in Figure 7, the inclined guide ramp wall 45 is provided with a plurality of vertical guide ribs 55 disposed spaced-apart and axially oriented towards the air inlet end 46 to redirect airflow from the airflow path impinging thereupon angularly as illustrated by arrows 55' and from either side thereof. This helps in captivating and reorienting wind from the side of the wind powered turbine housing.

Referring now to Figure 9, there is shown a further modification of the wind powered turbine 10 of the present invention. As hereinshown, the turbine 10 is adapted to operate as a bi-directional turbine, that is to say from the front end or rear end thereof and oriented to

- 12 -

capture most of the predominant winds. In order to do this effectively, there is connected at the outlet end of the housing a top and bottom outlet gate 60 and 61, respectively, and these gates are biased by shocks 62 and 5 63, respectively, and operated in a similar fashion with a wire and pulley assembly operated by a motor to adjust the position of the top and bottom outlet gates. These gates would be operated automatically by a system controller 75, as shown in Figure 10, and which will be described later, 10 which senses the wind direction and wind speed. As hereinshown, the top outlet gate 60 is hingedly connected at 64 to a top end of the rear end of the frame 11 and the bottom outlet gate 61 hingedly connected at substantially midway of the rear end of the frame, as identified by 15 reference numeral 65.

As shown in Figure 9, the outlet gates 60 and 61 are in their normal open position with the wind directed into the front end of the wind turbine housing 10 and exiting in the back between the gates 60 and 61 which are 20 positioned to provide an unobstructed air stream. When the wind is directed from the rear of the housing, the top outlet gate 10 is displaced to its position, as indicated by phantom lines 66, and the bottom outlet gate 61 is displaced to its position, as indicated in phantom lines 25 67. Accordingly, air is admitted into the lower half portion of the housing to create a reverse actuating airflow path 68 impinging upon the radial blade members or vanes 16 in a lower part of the housing or frame. In order not to obstruct the outlet of this reverse airflow 30 path 68, the inclined guide ramp wall 45 has a hinge ramp section 45' which is hingeable inwards, as shown in solid line in Figure 9, to create an opening 69 below the air inlet end 46 for the passage of the reverse actuating airflow 68. Also, the hinge ramp section 45 provides a

- 13 -

guide wall surface for the reverse actuating airflow path. As hereinshown, the ramp section 45' is actuated by a shock 70 and pulley and cable mechanism, not shown, which may be operated by the system controller 75 or by a piston
5 controlled by the controller unit, although not desirable. Accordingly, it can be seen that the wind powered turbine can operate from either the front or rear thereof and be able to captivate winds angulated thereto.

Referring now to Figure 8A, there is shown two
10 wind powered turbines 10 and 10' constructed in accordance with the present invention and interconnected in side-by-side relationship. To effect this interconnection, the rotor shafts 13 and 13' of respective wind powered turbines 10 and 10', need to be interconnected. This is
15 accomplished, as shown in Figure 8B, by a flexible coupling whereby to couple the rotor shafts to form a common rotor shaft to drive the electric motor 19 connected at an end of the series connected wind powered turbines. There can be several of these turbines 10, 10'
20 interconnected side-by-side, as illustrated in Figure 10.

As shown in Figure 8B, the flexible coupling is herein comprised by a sprocket 80 and 80' secured respectively to an adjacent end of the adjacent rotor shafts 13 and 13' and interconnected together by a
25 circular chain link belt 81 engaged about both sprockets 80 and 80' and retaining them in side-by-side relationship to permit flexibility between the interconnected rotor shafts 13 and 13' as each turbine is independent which causes the combined rotor shaft to vibrate due to the
30 torque generated by each rotor. The flexible coupling can have many different structures such as being constituted by a rubber bushing couplings or other mechanical coupling structures.

- 14 -

As shown in Figure 8C, these series of interconnected turbines can also be disposed in back-to-back spaced relationship on a surface 79 which may be the roof of a building or any other convenient surface where such an installation is desirable.

Although not shown, it is contemplated that the horizontal wind turbine can be mounted on a swivel base and may also have a wind fin or sensor to orient the turbine in the wind direction. Such an installation could be used where there is no electrical power available to supply a limited user load.

Referring now to Figure 10, there is shown a block diagram of a typical automated system to which the wind powered turbine 10 of the present invention may be connected to permit proportional regeneration of an electrical supply. As previously described, the rotor shaft of the wind turbine operates an electric motor 19 which generates a variable electrical output, depending on the rotational speed of the rotor shaft. This variable output is fed to a regenerative drive which is controlled with a torque set point. The set point varies with the actual wind speed. High winds involve a high torque set point which generates more power on the existing electrical network infrastructure. During very high winds, the maximum regeneration is maximized to the limit of the generator so the production never stops, even during very high winds. Such a regenerative drive is provided by ABB and herein schematically illustrated by the block 80. It can be adapted to drive an optional transformer 81 and/or the electrical network infrastructure 82 of a building. Integrated with this known electrical equipment is a system controller 75 which operates the venturi gate 47 and rear gates 60 and 61 (when provided) depending on wind direction. The

- 15 -

controller 75 is also fed signals from a wind speed sensor 83, a vibration sensor 84 and a noise sensor 85 to provide proper adjustments of the venturi gates and outlet gates to effect proper operation of the rotor to control these various parameters.

Figure 11 is a front view of a building 90 having secured on the roof 91 thereof wind turbines 10 constructed in accordance with the present invention. As hereinshown, there are seven of these wind turbines interconnected in a side-by-side relationship. They also blend well with the building and provide an aesthetic appearance to the building. They can, of course, also be painted to blend within the aesthetics of the building. Because of their lightweight structure, many of these turbines can be supported on the rooftops of buildings. It is also easier to capture wind on top of buildings often catching the updraft created by the building wall below the turbines. The electrical infrastructure is already close to the roof.

The wind powered turbine of the present invention offers several advantages:

- Can be installed on flat or inclined roofs
- Its horizontal configuration
- Its modular aspect (side-by-side)
- The shelter structure protects against bad weather conditions
- The doors are adjustable to increase, decrease or stop inlet wind.
- Each turbine section is 10' in length (however this dimension may vary)
- Lightweight structure
- Low height makes components easily accessible
- Can be installed on existing buildings

- 16 -

- Given size of the assembly, special installation permits may be avoided
- Can generate power from winds as low as 5 km/h which is typically 80% of winds in certain areas
- 5 - Can possibly sustain up to 200 km/h winds
- Wind deflection concentrates wind towards the wind catching vanes and improves power generation efficiency
- 10 - Structure of assembly easily accessible for maintenance with even a step-ladder
- If a wind catching vane fails, it may be easily replaced
- Assembly may be disassembled by hand
- 15 - Can be installed for residential, industrial, institutional applications
- Simple maintenance
- Low cost
- Overall size may be adjusted for different applications
- 20 - Assembly may be easily transported from one location to another
- As opposed to large wind turbines that require construction of specific access roads, the present assembly does not require such an
- 25 infrastructure for installation onsite
- Easy to manufacture
- Can resist to wind gusts
- Small, medium and large power applications can be designed from the same concept and simply
- 30 scaling the components appropriately
- Personnel within the building supporting the wind turbine can supervise operation of the turbine. No specially-qualified personnel is required

- 17 -

- Replacement parts are easily accessible and can be provided under short notice
- It may also directly produce hydrogen or heat water for future use.

5 It is within the ambit of the present invention to cover any obvious modifications of the preferred embodiment described herein provided such modifications fall within the scope of the appended claims.

CLAIMS,

1. A horizontal wind powered turbine comprising a frame on which is horizontally and rotatably supported a rotor on a rotor shaft, said rotor being formed by three or more radial blade members secured to said rotor shaft by securement means, said radial blade members being equidistantly spaced from one another, each said radial blade member having support arms and a wind vane secured to an outer end portion of said support arms, said wind vane being shaped to capture an airflow directed thereagainst for displacement thereof to create a rotational force about said rotor shaft to rotate said rotor shaft about a longitudinal central axis thereof, said radial blade members being rigidly interconnected to one another at an outer end portion thereof by tension adjustable bracing means, and wind channeling guide means to accelerate and direct said airflow in an actuating airflow path to impinge upon said wind vanes positioned in said actuating airflow path to displace said wind vane by wind drag.

2. A horizontal wind powered turbine as claimed in claim 1 wherein said tension adjustable bracing means is comprised by tie-wires of equal lengths secured to an adjustable wire connector secured to said support arms of said radial blade members.

3. A horizontal wind powered turbine as claimed in claim 2 wherein said adjustable wire connector is secured to a free outer end of each said support arms, said wind vane being secured between two support arms.

- 19 -

4. A horizontal wind powered turbine as claimed in claim 3 wherein said adjustable wire connector is a wire retention member displaceable by positioning means along a longitudinal axis of said support arms.

5. A horizontal wind powered turbine as claimed in claim 4 wherein said wire retention member is a wire attachment sleeve about which loop ends of opposed tie-wires are retained captive, said wire attachment sleeve being displaced along a threaded bolt secured in a top end of said support arms, said positioning means being lock nuts threadably secured to said threaded bolt with said sleeve held captive therebetween.

6. A horizontal wind powered turbine as claimed in claim 3 wherein said adjustable wire connector is an adjustable bolt connector having a threaded shaft portion threadably connected in said free outer end, a wire attaching sleeve supported by said threaded shaft portion for captively receiving an end attaching loop of opposed tie-wires, said bolt connector having an engageable outer head to impart rotation of said bolt connector to cause displacement of said wire attaching sleeve to increase or decrease tension in said opposed tie-wires to balance and strengthen said radial blade members about said rotor shaft.

7. A wind powered turbine as claimed in claim 3 wherein said securement means is comprised by two shaft connecting assemblies, each assembly having three or more rigid posts immovably secured to said shaft and spaced apart to displaceably interconnect with an inner connecting end portion of said two support arms of said three or more radial blade members.

- 20 -

8. A wind powered turbine as claimed in claim 7 wherein said rigid posts are hollow tubular posts, said support arms being straight rods having a cross-section for close sliding fit engagement in respective ones of said hollow tubular posts, and arresting means to temporarily immovably secure said straight rods in said hollow tubular posts at a predetermined position.

9. A wind powered turbine as claimed in claim 8 wherein there is further provided spring biasing means held captive in said hollow tubular posts to permit axial displacement of said straight rods due to thermal expansion and contraction, said tie-wires maintaining said solid rods captive in said hollow tubular posts.

10. A wind powered turbine as claimed in claim 7 wherein said two shaft connecting assemblies further comprises flat disc connectors having a hub secured to said shaft, said three or more rigid posts being secured to a side wall of said flat disc.

11. A wind powered turbine as claimed in claim 10 wherein said shaft connecting assemblies are made of steel, said two support arms and said wind vane being constructed of lightweight aluminum material.

12. A wind powered turbine as claimed in claim 1 wherein said wind vanes are shaped as brackets having an elongated inwardly curved inner wall and opposed transverse end walls, said opposed transverse end walls having a straight forward edge, said support arms being straight support arms, said outer end portion of said

- 21 -

support arms being secured to a respective one of said straight forward edge of said transverse end walls.

13. A wind powered turbine as claimed in claim 12 wherein said inwardly curved inner wall has a cross-sectional shape which is one of semi-elliptical or semi-circular.

14. A wind powered turbine as claimed in claim 12 wherein said transverse end walls are wind captivating end walls, and wherein there is further provided one or more spaced intermediate wind captivating walls between said end walls.

15. A wind powered turbine as claimed in claim 14 wherein at least a further one of said support arms is secured to said straight forward edge of one or more of said intermediate wind captivating walls.

16. A wind powered turbine as claimed in claim 1 wherein said wind channeling guide means comprises an air inlet channeling structure comprised by an inclined guide ramp wall below an air inlet end of said frame and an adjustable venturi gate hingedly secured to said frame above said air inlet end, said adjustable venturi gate having an inner wall surface defining a curvature to impart a venturi effect to said airflow upwind of said air inlet end when positioned a predetermined distance spaced from said ramp wall to accelerate said airflow.

17. A wind powered turbine as claimed in claim 16 wherein said adjustable venturi gate is displaceable from an open position to a closed position, when in said closed position said adjustable gate substantially obstructs said

- 22 -

air inlet end, said adjustable gate being biased to said open position by pressure exerting means and gate displacement means to displace and retain said gate at a desired position against said pressure exerting means.

18. A wind powered turbine as claimed in claim 17 wherein said pressure exerting means is constituted by one or more shocks.

19. A wind powered turbine as claimed in claim 16 wherein said ramp wall is provided with a plurality of vertical guide ribs disposed spaced-apart and axially oriented towards said air inlet end to redirect air from said airflow path impinging thereupon angularly.

20. A wind powered turbine as claimed in claim 17 wherein said gate displacement means is comprised by a pulley and cable motor driven mechanism controlled by a controller unit.

21. A wind powered turbine as claimed in claim 17 wherein said gate displacement means is comprised by a mechanically adjustable mechanism.

22. A wind powered turbine as claimed in claim 16 wherein said frame is provided with an outwardly curved top wall spaced above said radial blade members and extending from said air inlet end to an outlet end.

23. A wind powered turbine as claimed in claim 16 wherein said wind powered turbine is a bi-directional turbine, and wherein a rear end of said frame is provided with top and bottom outlet gates hingedly secured to a top half and lower half portion of said frame above said half

- 23 -

options, said outlet gates being biased in an open position by pressure exerting means, and gate displacement means to position said outlet gates to guide back winds into said lower half portion of said frame to create a reverse actuating airflow path to impinge upon said radial blade members in a lower portion of said frame, said inclined guide ramp wall having a hinged ramp section hingeable inward to create an opening below said air inlet end for the passage and guidance of said reverse actuating airflow path, said hinged ramp section providing a guide wall surface for said reverse actuating airflow path.

24. A wind powered turbine as claimed in claim 1 wherein two or more of said wind powered turbines are disposed in side-by-side relationship with their rotor shaft interconnected by a flexible coupling to form a common rotor shaft driven by said two or more wind power turbines.

25. A wind powered turbine as claimed in claim 24 wherein said flexible coupling is comprised of a sprocket secured to adjacent ends of said rotor shaft, said sprockets being interconnected together by a chain link belt engaged about said sprockets to permit flexibility between said interconnected rotor shafts.

26. A wind powered turbine as claimed in claim 24 wherein said wind powered turbines are further disposed in spaced back-to-back spaced relationship.

27. A wind powered turbine as claimed in claim 17 wherein said rotor shaft is drivingly connected to an electric motor to generate a variable electric voltage, a regenerative drive with a torque set point supplies a

- 24 -

regulated output voltage to an electrical network infrastructure of a building to be supplied by said wind powered turbine.

28. A wind powered turbine as claimed in claim 27 wherein there is further comprised a system controller for controlling said wind powered turbine, said controller controlling said gate displacement means, and sensors secured to said controller for monitoring wind speed, noise and vibration.

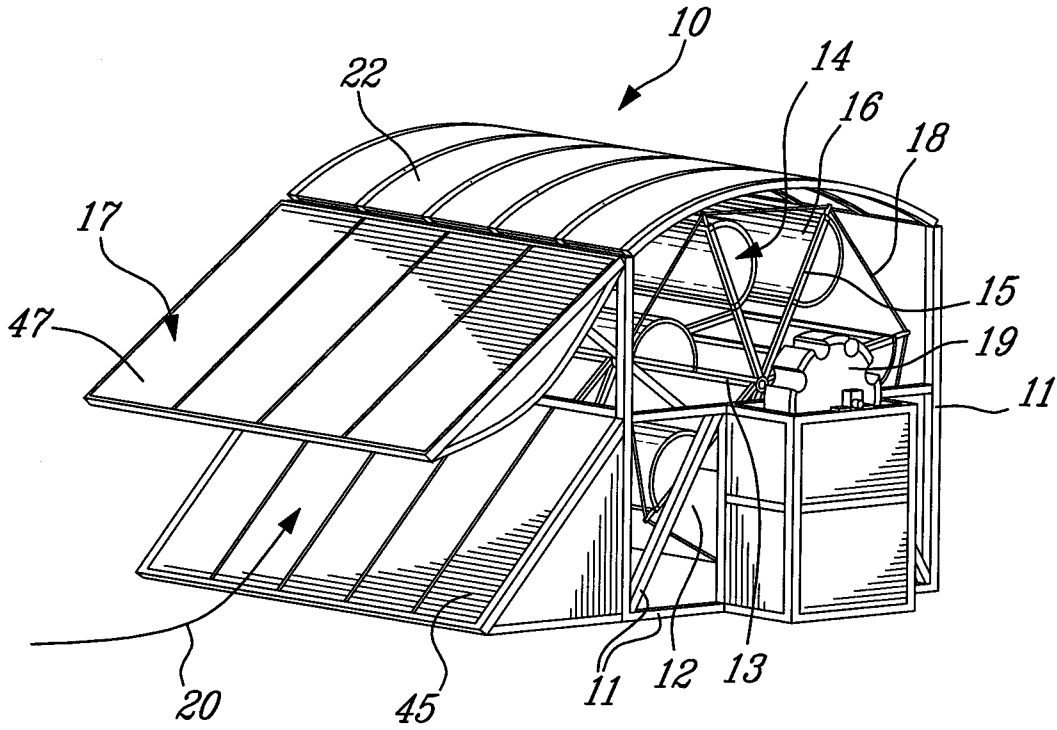

Fig-1A

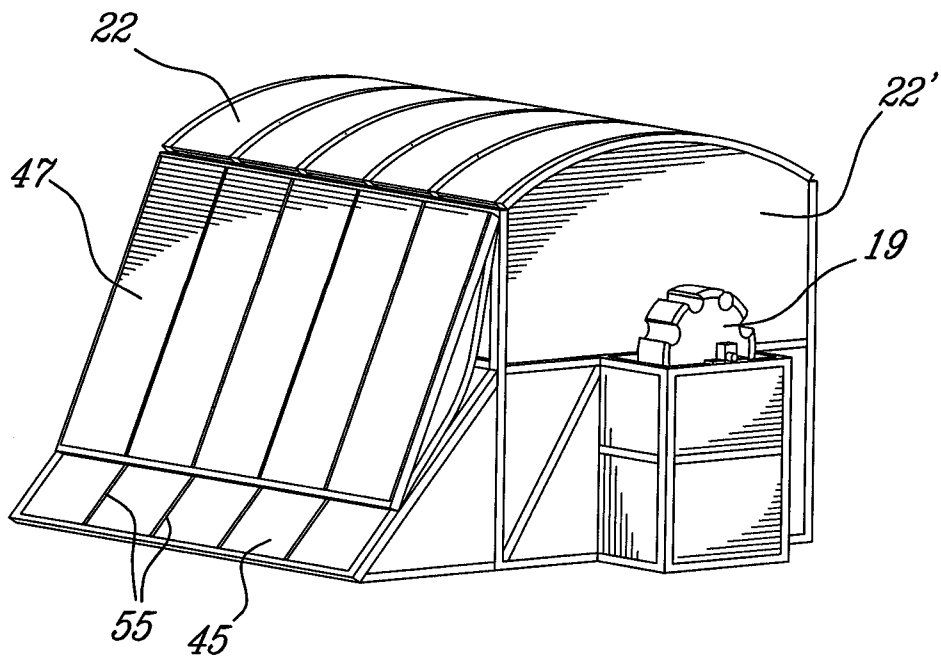

Fig-1B

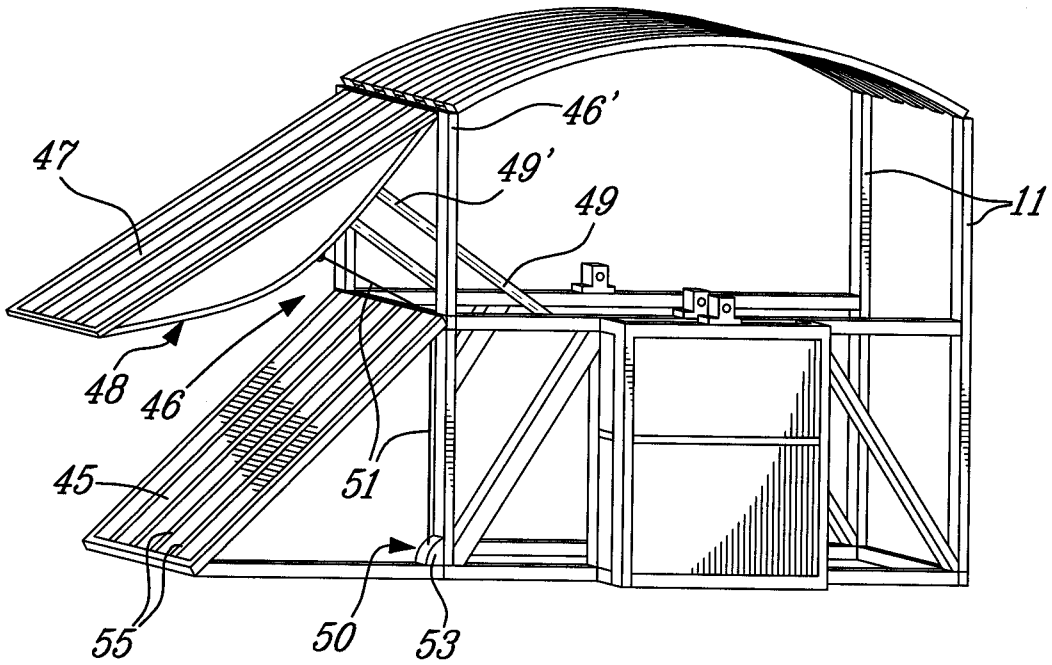

Fig-2

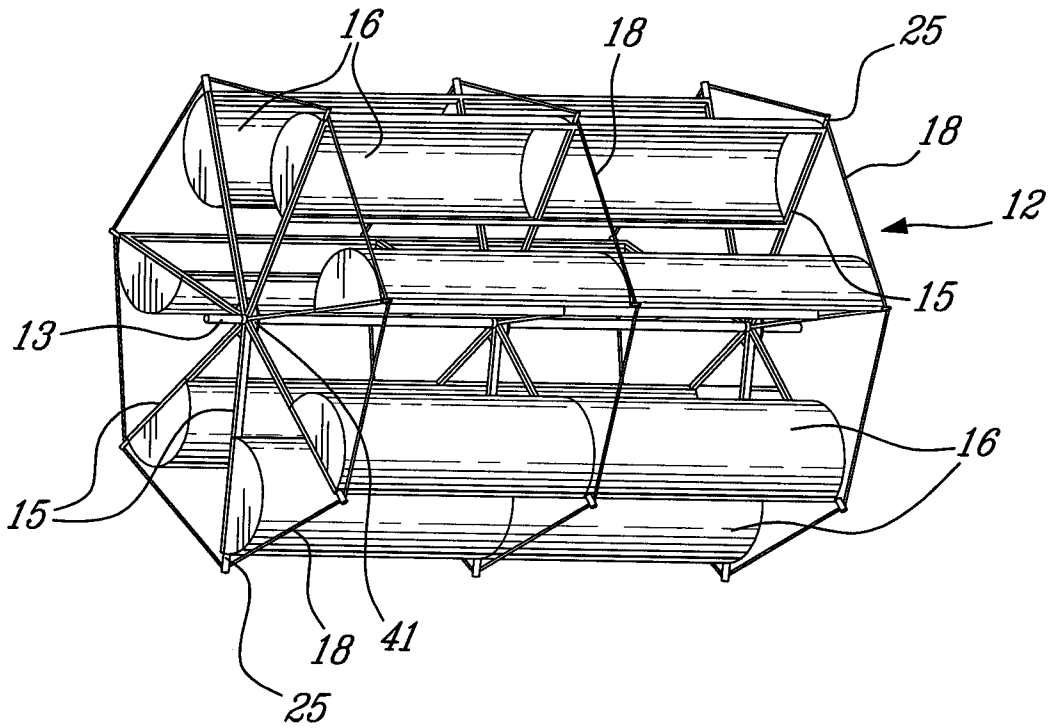

Fig-3

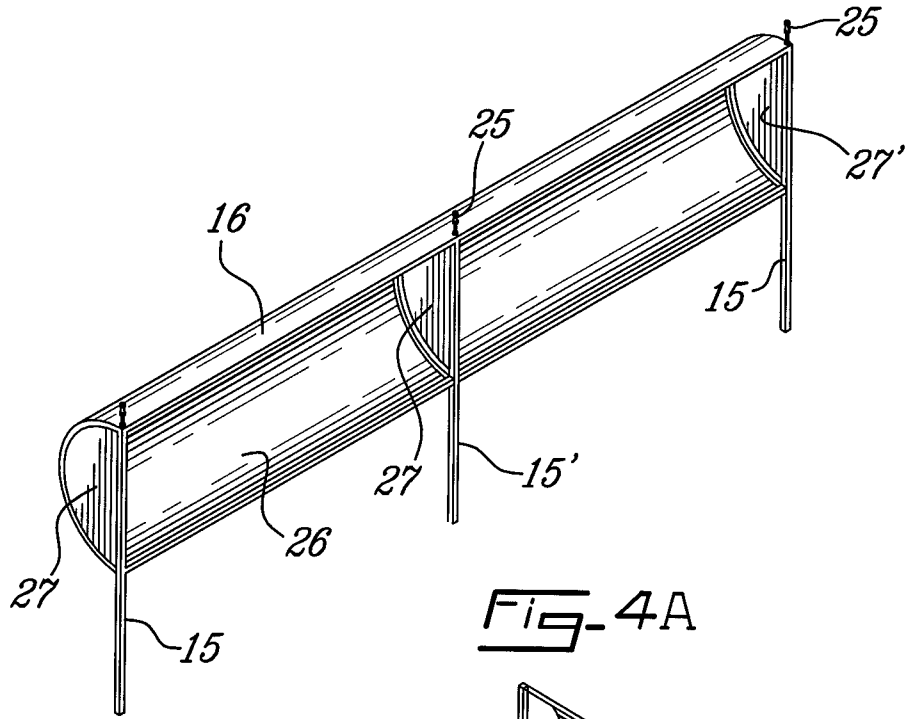

Fig-4A

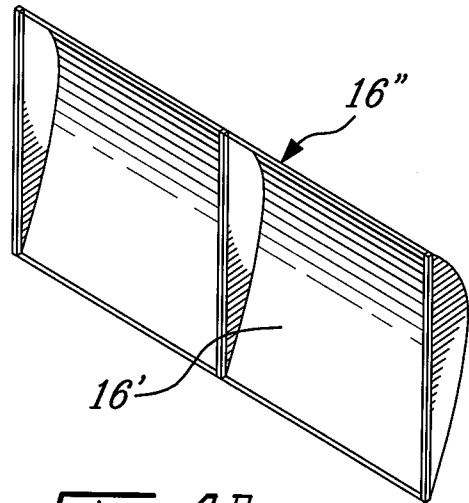

Fig-4B

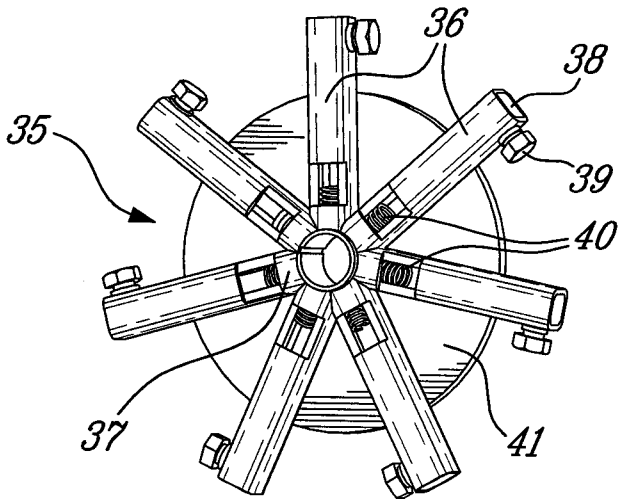

Fig-5

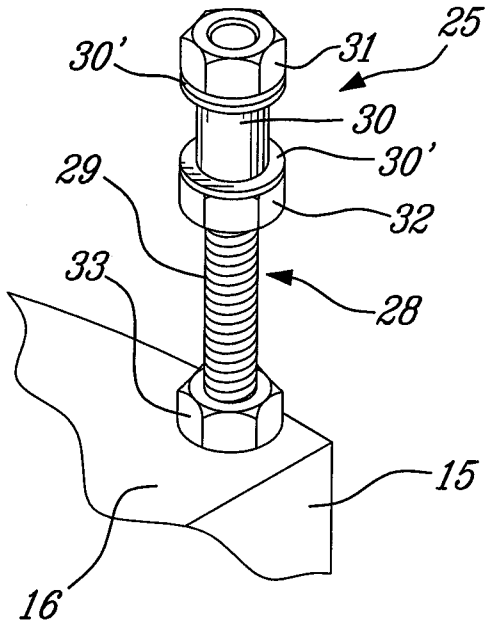

Fig-6A

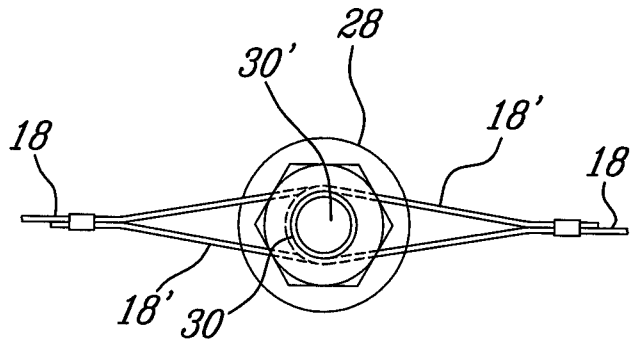

Fig-6B

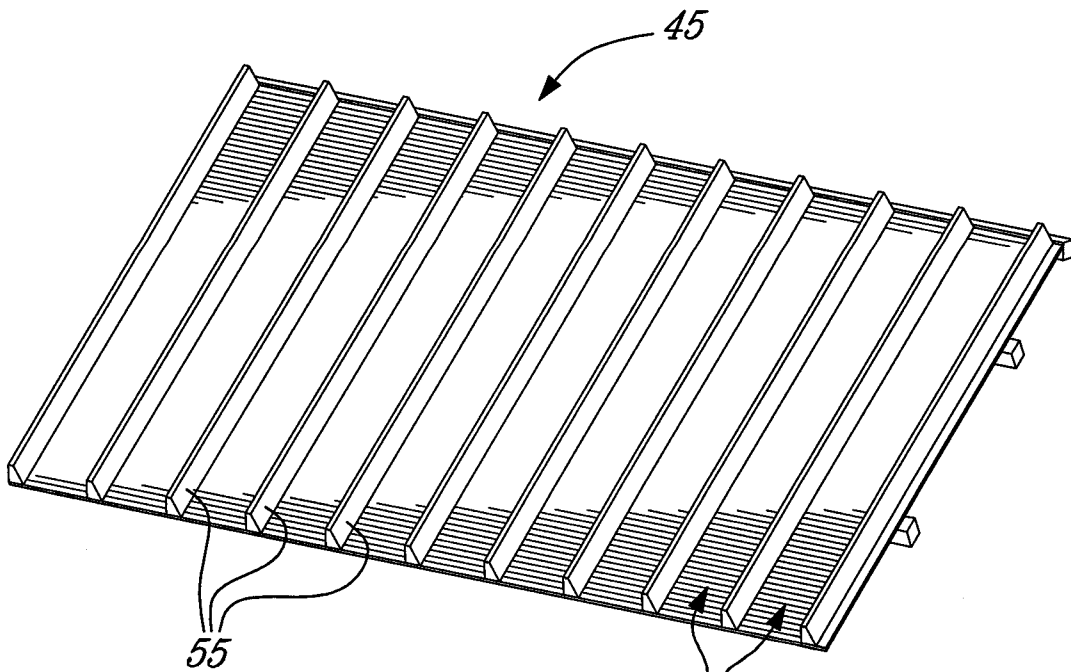

Fig-7 55'

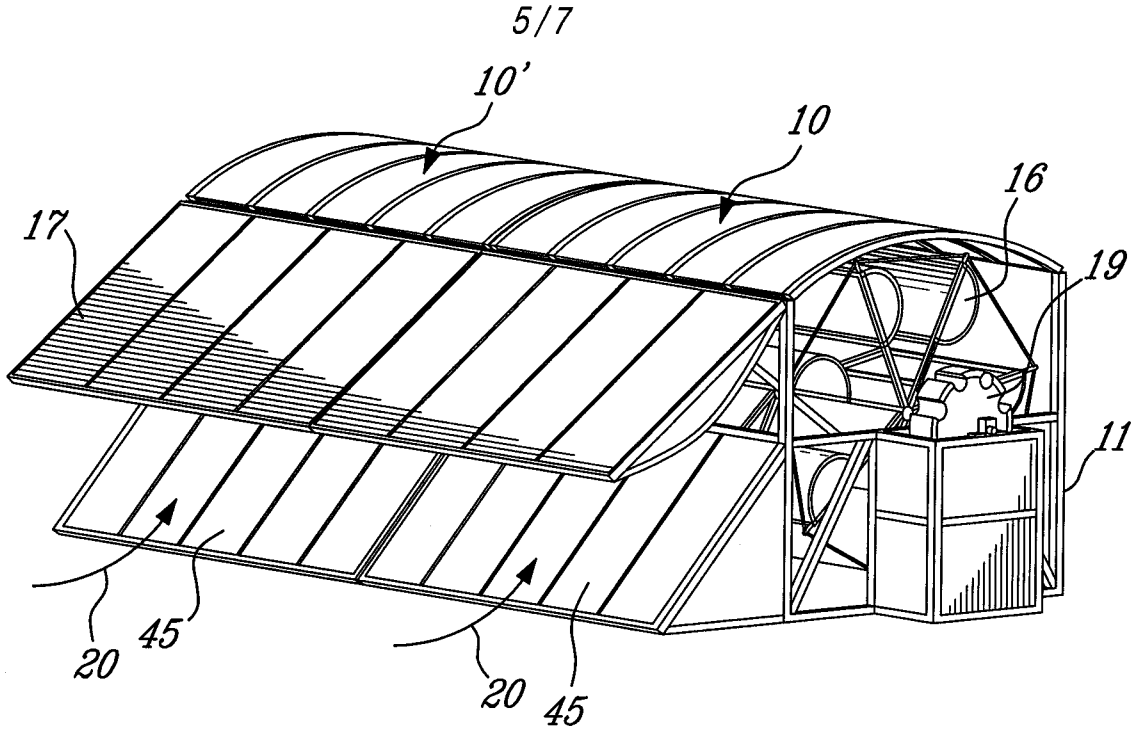

Fig- 8A

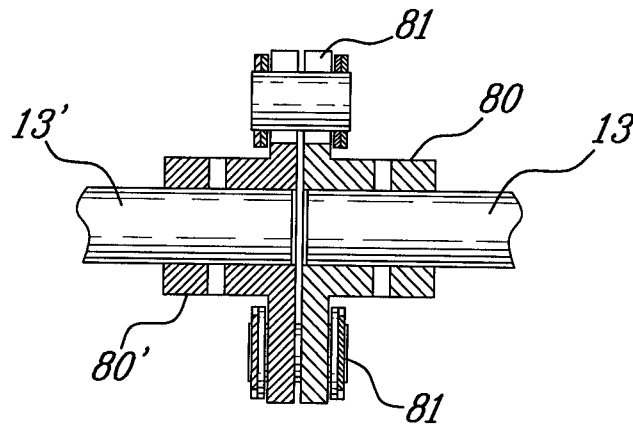

Fig- 8B

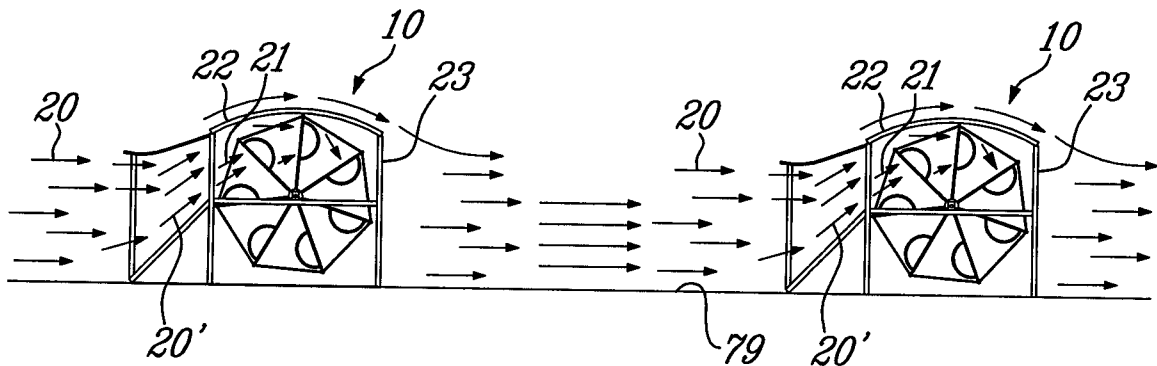
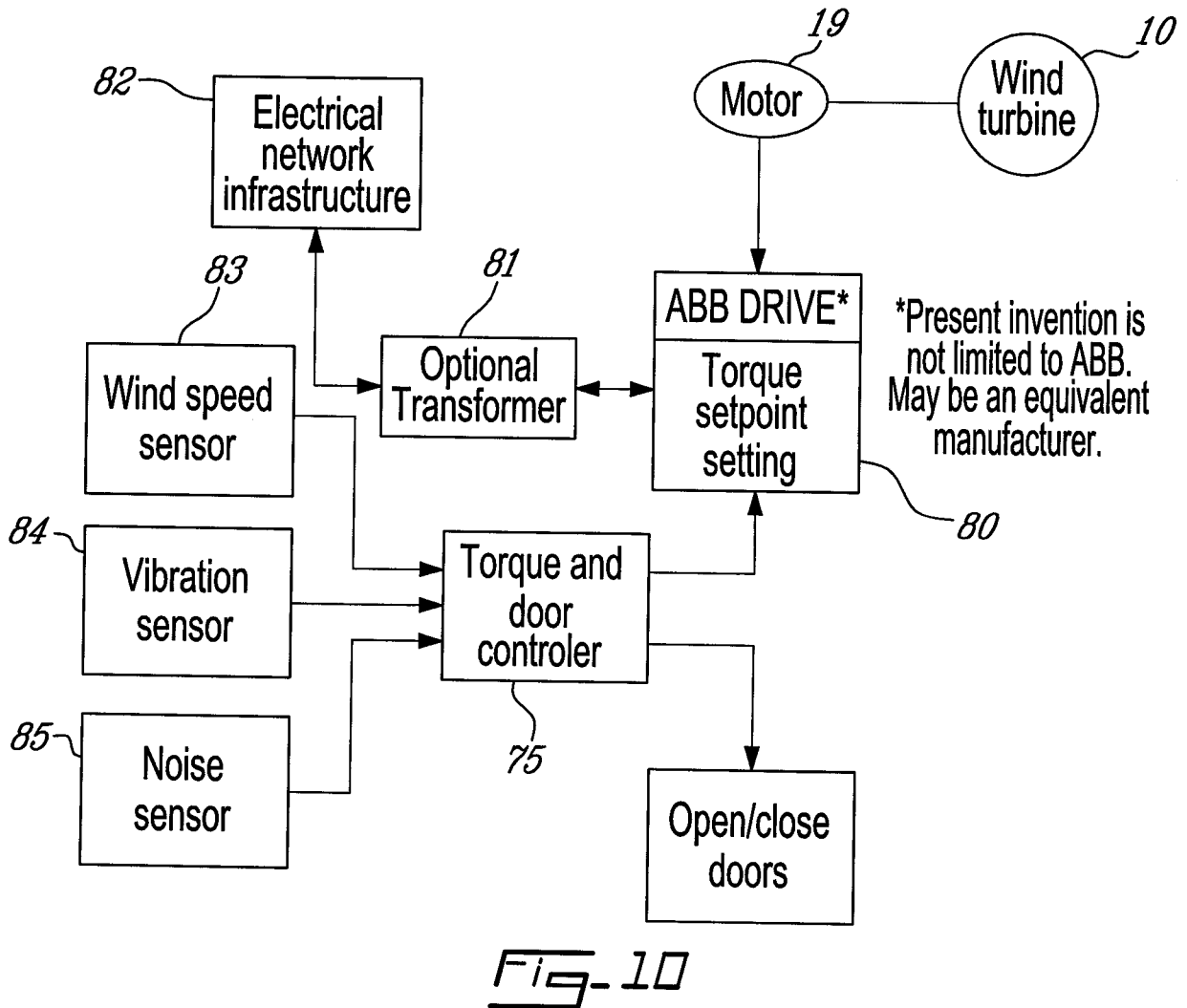
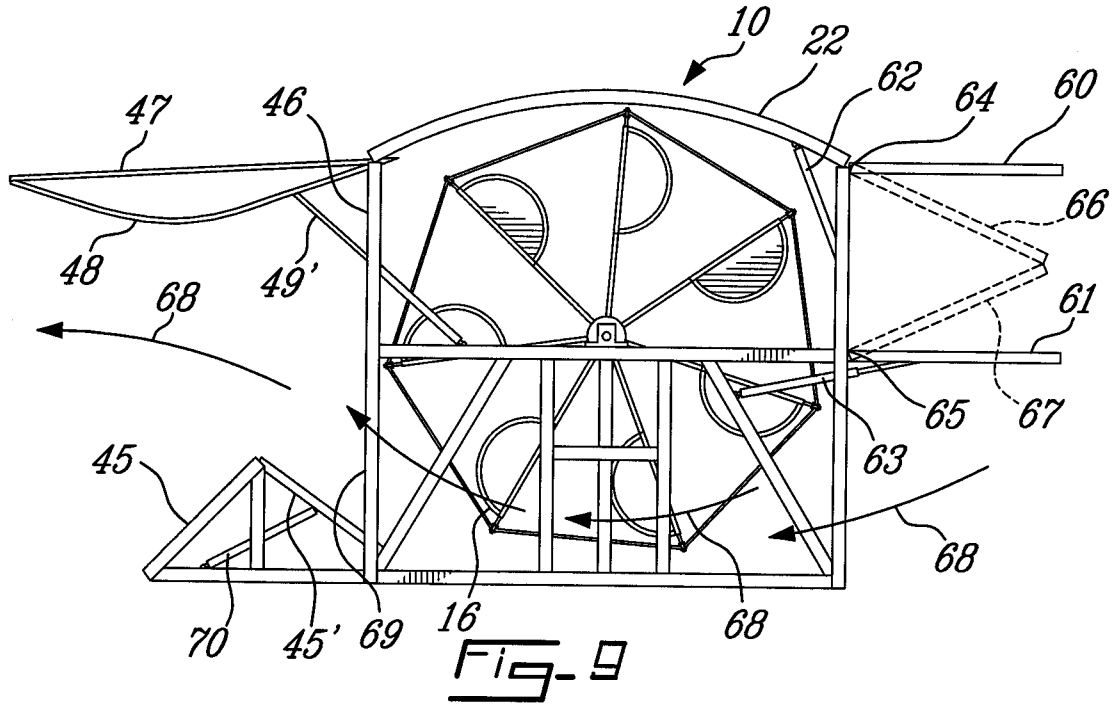

Fig- 8C



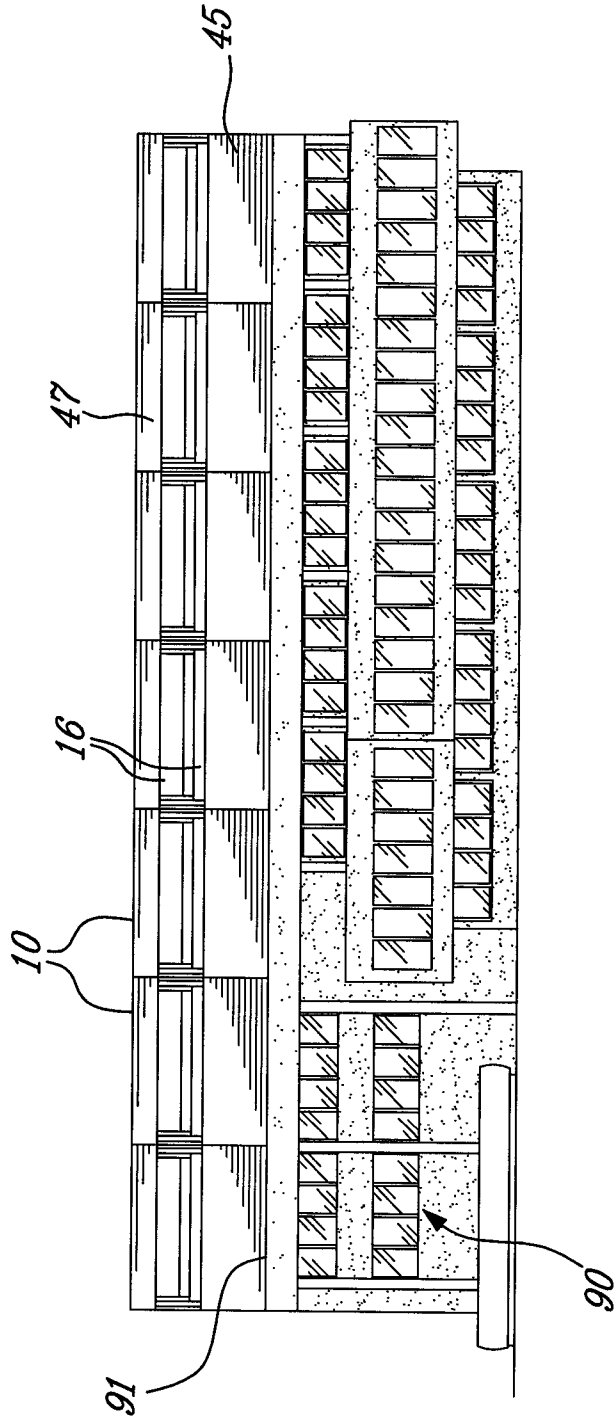

FIG-11

INTERNATIONAL SEARCH REPORT

International application No.
PCT/CA2010/000528

<p>A. CLASSIFICATION OF SUBJECT MATTER IPC: F03D 3/04 (2006.01) , F03D 3/06 (2006.01) , F03D 7/06 (2006.01) According to International Patent Classification (IPC) or to both national classification and IPC</p>																						
<p>B. FIELDS SEARCHED</p> <p>Minimum documentation searched (classification system followed by classification symbols) IPC: F03D (2006.01) USPC: 415, 416, 290 CPC: 170</p> <p>Documentation searched other than minimum documentation to the extent that such documents are included in the fields searched</p> <p>Electronic database(s) consulted during the international search (name of database(s) and, where practicable, search terms used) EPOQUE (X-FULL), USPTO, Canadian Patent Database Keywords: wind, turbine, horizontal, concave, wire, cable, arm, eolienne</p>																						
<p>C. DOCUMENTS CONSIDERED TO BE RELEVANT</p> <table border="1"> <thead> <tr> <th>Category*</th> <th>Citation of document, with indication, where appropriate, of the relevant passages</th> <th>Relevant to claim No.</th> </tr> </thead> <tbody> <tr> <td>A</td> <td>US 6857846 B2 (MILLER, L.) 22 February 2005 (22-02-2005) *Abstract; Fig. 3; Col. 4, lines 50-62; Col. 5, lines 19-24; Col. 6, lines 30-34 *</td> <td>1-28</td> </tr> <tr> <td>A</td> <td>US 6402472 B1 (HOGUE, A. et al.) 11 June 2002 (11-06-2002) * Fig. 1; Col. 3, line 49 - Col. 4, line 33 *</td> <td>1-28</td> </tr> <tr> <td>A</td> <td>US 5083902 A1 (RHODES, W.) 28 January 1992 (28-01-1992) * Abstract; Fig. 1; Col. 5, lines 47-50 *</td> <td>1-28</td> </tr> <tr> <td>A</td> <td>FR 2292878 A1 (SAHORES, J.) 25 June 1976 (25-06-1976) * Fig. 7,8 *</td> <td>1-28</td> </tr> <tr> <td>A</td> <td>US 1407373 A1 (BRYMER, P.) 21 February 1922 (21-02-1922) * Fig. 1,2 *</td> <td>1-28</td> </tr> <tr> <td>A</td> <td>US 648442 A1 (SCOTT, O. F.) 01 May 1900 (01-05-1900) * Whole document *</td> <td>1-28</td> </tr> </tbody> </table>		Category*	Citation of document, with indication, where appropriate, of the relevant passages	Relevant to claim No.	A	US 6857846 B2 (MILLER, L.) 22 February 2005 (22-02-2005) *Abstract; Fig. 3; Col. 4, lines 50-62; Col. 5, lines 19-24; Col. 6, lines 30-34 *	1-28	A	US 6402472 B1 (HOGUE, A. et al.) 11 June 2002 (11-06-2002) * Fig. 1; Col. 3, line 49 - Col. 4, line 33 *	1-28	A	US 5083902 A1 (RHODES, W.) 28 January 1992 (28-01-1992) * Abstract; Fig. 1; Col. 5, lines 47-50 *	1-28	A	FR 2292878 A1 (SAHORES, J.) 25 June 1976 (25-06-1976) * Fig. 7,8 *	1-28	A	US 1407373 A1 (BRYMER, P.) 21 February 1922 (21-02-1922) * Fig. 1,2 *	1-28	A	US 648442 A1 (SCOTT, O. F.) 01 May 1900 (01-05-1900) * Whole document *	1-28
Category*	Citation of document, with indication, where appropriate, of the relevant passages	Relevant to claim No.																				
A	US 6857846 B2 (MILLER, L.) 22 February 2005 (22-02-2005) *Abstract; Fig. 3; Col. 4, lines 50-62; Col. 5, lines 19-24; Col. 6, lines 30-34 *	1-28																				
A	US 6402472 B1 (HOGUE, A. et al.) 11 June 2002 (11-06-2002) * Fig. 1; Col. 3, line 49 - Col. 4, line 33 *	1-28																				
A	US 5083902 A1 (RHODES, W.) 28 January 1992 (28-01-1992) * Abstract; Fig. 1; Col. 5, lines 47-50 *	1-28																				
A	FR 2292878 A1 (SAHORES, J.) 25 June 1976 (25-06-1976) * Fig. 7,8 *	1-28																				
A	US 1407373 A1 (BRYMER, P.) 21 February 1922 (21-02-1922) * Fig. 1,2 *	1-28																				
A	US 648442 A1 (SCOTT, O. F.) 01 May 1900 (01-05-1900) * Whole document *	1-28																				
<p><input checked="" type="checkbox"/> Further documents are listed in the continuation of Box C. <input checked="" type="checkbox"/> See patent family annex.</p> <table border="1"> <tr> <td>* Special categories of cited documents :</td> <td>"T" later document published after the international filing date or priority date and not in conflict with the application but cited to understand the principle or theory underlying the invention</td> </tr> <tr> <td>"A" document defining the general state of the art which is not considered to be of particular relevance</td> <td>"X" document of particular relevance; the claimed invention cannot be considered novel or cannot be considered to involve an inventive step when the document is taken alone</td> </tr> <tr> <td>"E" earlier application or patent but published on or after the international filing date</td> <td>"Y" document of particular relevance; the claimed invention cannot be considered to involve an inventive step when the document is combined with one or more other such documents, such combination being obvious to a person skilled in the art</td> </tr> <tr> <td>"L" document which may throw doubts on priority claim(s) or which is cited to establish the publication date of another citation or other special reason (as specified)</td> <td>"&" document member of the same patent family</td> </tr> <tr> <td>"O" document referring to an oral disclosure, use, exhibition or other means</td> <td></td> </tr> <tr> <td>"P" document published prior to the international filing date but later than the priority date claimed</td> <td></td> </tr> </table>		* Special categories of cited documents :	"T" later document published after the international filing date or priority date and not in conflict with the application but cited to understand the principle or theory underlying the invention	"A" document defining the general state of the art which is not considered to be of particular relevance	"X" document of particular relevance; the claimed invention cannot be considered novel or cannot be considered to involve an inventive step when the document is taken alone	"E" earlier application or patent but published on or after the international filing date	"Y" document of particular relevance; the claimed invention cannot be considered to involve an inventive step when the document is combined with one or more other such documents, such combination being obvious to a person skilled in the art	"L" document which may throw doubts on priority claim(s) or which is cited to establish the publication date of another citation or other special reason (as specified)	"&" document member of the same patent family	"O" document referring to an oral disclosure, use, exhibition or other means		"P" document published prior to the international filing date but later than the priority date claimed										
* Special categories of cited documents :	"T" later document published after the international filing date or priority date and not in conflict with the application but cited to understand the principle or theory underlying the invention																					
"A" document defining the general state of the art which is not considered to be of particular relevance	"X" document of particular relevance; the claimed invention cannot be considered novel or cannot be considered to involve an inventive step when the document is taken alone																					
"E" earlier application or patent but published on or after the international filing date	"Y" document of particular relevance; the claimed invention cannot be considered to involve an inventive step when the document is combined with one or more other such documents, such combination being obvious to a person skilled in the art																					
"L" document which may throw doubts on priority claim(s) or which is cited to establish the publication date of another citation or other special reason (as specified)	"&" document member of the same patent family																					
"O" document referring to an oral disclosure, use, exhibition or other means																						
"P" document published prior to the international filing date but later than the priority date claimed																						
<p>Date of the actual completion of the international search</p> <p>29 June 2010 (29-06-2010)</p>	<p>Date of mailing of the international search report</p> <p>8 July 2010 (08-07-2010)</p>																					
<p>Name and mailing address of the ISA/CA</p> <p>Canadian Intellectual Property Office Place du Portage I, C114 - 1st Floor, Box PCT 50 Victoria Street Gatineau, Quebec K1A 0C9 Facsimile No.: 001-819-953-2476</p>	<p>Authorized officer</p> <p>Gilbert Plouffe (819) 997-9811</p>																					

INTERNATIONAL SEARCH REPORTInternational application No.
PCT/CA2010/000528

C (Continuation). DOCUMENTS CONSIDERED TO BE RELEVANT

Category*	Citation of document, with indication, where appropriate, of the relevant passages	Relevant to claim No.
A	FR 365045 A1 (LOUBIERE, A.) 01 September 1906 (01-09-1906) * Whole document *	1-28
A	GB 188732 A1 (SCOTT, J. R.) 09 November 1922 (09-11-1922) * Fig. 1,2 *	1-28
A	US 325025 A1 (TEFFT, P.) 25 August 1885 (25-08-1885) * Fig.1 *	1-28
A	GB 2185786 A1 (PARKINSON, N.) 29 July 1987 (29-07-1987) * Abstract; Fig. 1-4 *	1-28
A	US 6981839 B2 (FAN, L.) 03 January 2006 (03-01-2006) * Fig. 1-8 *	1-28

INTERNATIONAL SEARCH REPORT
Information on patent family members

International application No.
PCT/CA2010/000528

Patent Document Cited in Search Report	Publication Date	Patent Family Member(s)	Publication Date
US6857846B2	22-02-2005	US2003059306A1 US2004184909A1	27-03-2003 23-09-2004
US6402472B1	11-06-2002	US6402472B1	11-06-2002
US5083902A	28-01-1992	EP0296211A1 EP0296211A4 WO8804730A1	28-12-1988 27-04-1989 30-06-1988
FR2292878A	25-06-1976	NONE	NONE
US1407373A	21-02-1922	US1407373A	21-02-1922
US648442A	01-05-1900	NONE	NONE
FR365045A	01-09-1906	NONE	NONE
GB188732A	09-11-1922	NONE	NONE
US325025A	25-08-1885	NONE	NONE
GB2185786A	29-07-1987	NONE	NONE
US6981839B2	03-01-2006	AU2005221199A1 CA2557242A1 CN1930393A EP1664624A2 EP1664624A4 EP1673258A1 EP1725768A2 EP1725768A4 EP1741145A1 EP1741145A4 EP1743196A1 JP2007528467T RU2006133927A US6420262B1 US2002182858A1 US6743716B2 US6819505B1 US2003107885A1 US6827468B2 US2004109310A1 US6942365B2 US2004201995A1 US6966677B2 US2004114393A1 US6974234B2 US2005201855A1 US2005216143A1 US7050890B2 US2004190285A1 US7055989B2 US2004212991A1	22-09-2005 22-09-2005 14-03-2007 07-06-2006 17-12-2008 28-06-2006 29-11-2006 09-12-2009 10-01-2007 19-11-2008 17-01-2007 11-10-2007 20-04-2008 16-07-2002 05-12-2002 01-06-2004 16-11-2004 12-06-2003 07-12-2004 10-06-2004 13-09-2005 14-10-2004 22-11-2005 17-06-2004 13-12-2005 15-09-2005 29-09-2005 23-05-2006 30-09-2004 06-06-2006 28-10-2004

INTERNATIONAL SEARCH REPORTInternational application No.
PCT/CA2010/000528

US7083305B2	01-08-2006
US2005161692A1	28-07-2005
US7118255B2	10-10-2006
US2005017366A1	27-01-2005
US7121680B2	17-10-2006
US2005024864A1	03-02-2005
US7153004B2	26-12-2006
US2005161684A1	28-07-2005
US7201492B2	10-04-2007
US2002177302A1	28-11-2002
US7301190B2	27-11-2007
US2002182859A1	05-12-2002
US7378737B2	27-05-2008
US2006255462A1	16-11-2006
US7535103B2	19-05-2009
US2006145180A1	06-07-2006
US7652303B2	26-01-2010
US2004217481A1	04-11-2004
US2005201100A1	15-09-2005
US2009243106A1	01-10-2009
US2010148208A1	17-06-2010
WO2005025935A1	24-03-2005
WO2005026790A1	24-03-2005
WO2005027574A2	24-03-2005
WO2005027574A3	06-05-2005
WO2005060376A2	07-07-2005
WO2005060376A3	13-10-2005
WO2005060376B1	10-11-2005
WO2005086959A2	22-09-2005
WO2005086959A3	15-06-2006
WO2005109533A1	17-11-2005
ZA200607825A	30-07-2008