

(No Model.)

C. L. JOHNS.
COTTON SACK CARRIER.

No. 526,395.

Patented Sept. 25, 1894.

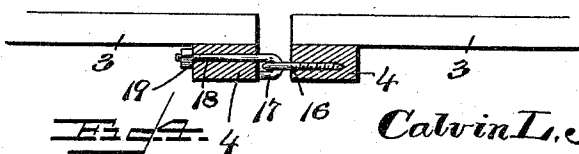
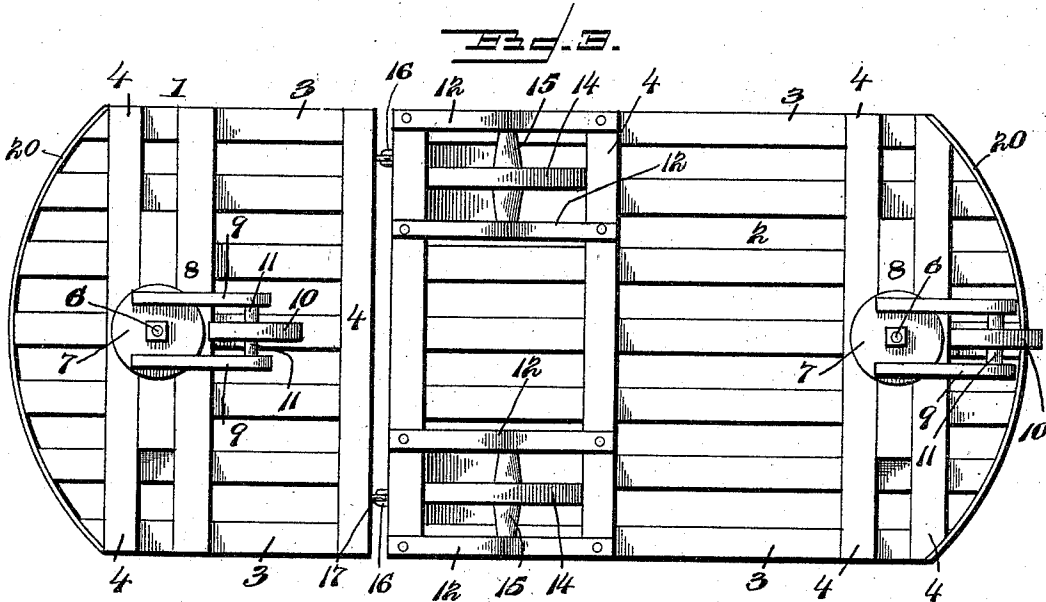
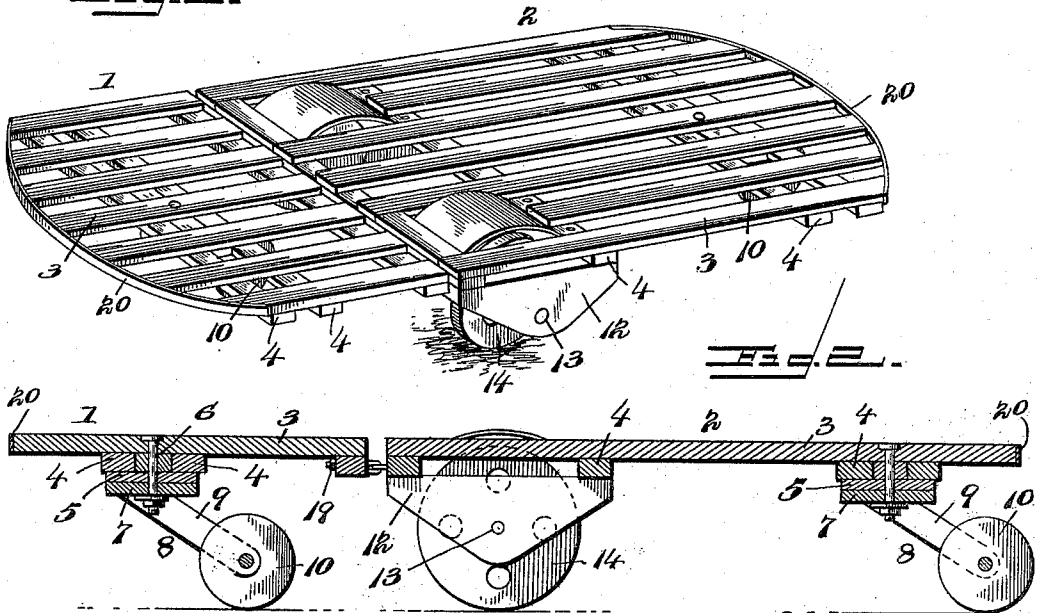

Inventor

Calvin L. Johns

Witnesses

E. H. Stewart
O. J. Duff

By *Two* Attorneys.

Calvin L. Johns

UNITED STATES PATENT OFFICE.

CALVIN L. JOHNS, OF KEMP, TEXAS.

COTTON-SACK CARRIER.

SPECIFICATION forming part of Letters Patent No. 526,395, dated September 25, 1894.

Application filed March 7, 1894. Serial No. 502,714. (No model.)

To all whom it may concern:

Be it known that I, CALVIN L. JOHNS, a citizen of the United States, residing at Kemp, in the county of Kaufman and State of Texas, have invented a new and useful Cotton-Sack Carrier, of which the following is a specification.

My invention relates to improvements in sack carriers, designed especially for use in transporting cotton sacks through the cotton field.

The function of the carrier is to support the sack into which cotton is placed as it is picked, and as it is drawn through the field by the operator or picker it is desirable that it should be so constructed as to yield readily to the movements of such persons as they turn from one row to another especially when, as in the usual practice, two parallel rows are being picked at the same time.

It is therefore the object of my invention to provide a device which will offer no impediment to the free movements of the picker.

A further object of my invention is to provide a construction such that the ends of the carrier will not engage and "hang" upon the stalks of cotton, and will pass readily over irregularities in the surface of the field.

Further objects and advantages of my invention will appear in the following description, and the novel features thereof will be particularly pointed out in the appended claim.

In the drawings: Figure 1 is a perspective view of a carrier embodying my invention. Fig. 2 is a central longitudinal section of the same. Fig. 3 is a bottom plan view thereof, to show the relative disposition of the supporting rollers or wheels. Fig. 4 is a detail section, showing the preferred pivotal or hinged connection between the sections of the carrier, whereby said parts may be disconnected.

Similar numerals of reference indicate corresponding parts in all the figures of the drawings.

The body of the carrier comprises the loosely connected front and rear sections, 1 and 2, respectively; the adjacent or connected ends of the said sections being squared and the outer or remote ends thereof being rounded, as shown. The sections are com-

posed of longitudinally disposed strips 3 which are connected at suitable points by transverse cleats 4. The cleats adjacent to the extremities or remote ends of the sections are arranged in pairs, and secured to their under surfaces are the disks 5, provided with central depending spindles 6, and mounted, revolubly, upon these spindles are the disk-portions 7 of the revoluble, caster-frames 8. Said caster-frames are provided with the parallel inclined arms 9, between the lower ends of which are mounted the rollers or wheels 10. The hubs of these rollers or wheels extend laterally, as shown at 11, and bear at their extremities against the inner surfaces of the parallel arms of the caster-frames.

The transverse cleats 4 which are arranged near the front end of the rear section are also disposed sufficiently close together to form bearings for the depending brackets 12, in which are formed bearings 13 for the axles of the side rollers or wheels 14, and the hubs 15 of said rollers or wheels bear at their extremities against the inner surfaces of the brackets 12.

The connection between the contiguous ends of the front and rear sections of the carrier consists of eyes 16 secured to the front end of the rear section, and eye-bolts 17 engaged in said eyes 16 and having their shanks, 18, passed through horizontal perforations in the rear transverse cleat 4 of the front section and engaged in front of the latter by nuts 19. By removing the nuts 19 the shanks of the eye-bolts may be withdrawn from the perforations in the cleat of the front section, thus disconnecting the sections. It is sometimes desirable, when a short sack is to be filled, to use only the rear section of the carrier, and hence the object in providing for the ready disconnection of the sections.

The projecting ends of the longitudinally disposed strips comprising the floor of the sections, are as above described rounded to avoid catching the stalks of the cotton and impeding the progress of the operator, and said projecting ends are covered by the curved guard strips 20, shown respectively at the front end of the front section and the rear end of the rear section. These guard strips are

preferably made of sheet metal, whereby they may be bent to conform to the configuration of the ends of the sections.

The swiveled caster-frames 8 are disposed, 5 as above described, adjacent to the outer or remote extremities of the carrier, while the twin side rollers or wheels are arranged opposite each other at an intermediate point, preferably at about the transverse center of 10 the carrier. Furthermore, the swiveled caster-frames are arranged at the ends of the longitudinal center of the carrier, or upon a line extending longitudinally of the carrier and passing between said side rollers or wheels. 15 Thus, the side rollers or wheels support the bulk of the weight of the load and steady the device laterally, while the casters support the terminals of the carrier and, being swiveled, turn freely in either direction to permit freedom of movement of the operator. 20 The relative disposition of the supporting rollers or wheels adapts the carrier to turn upon its center without either forward or retrograde movement. The casters are adjusted automatically by a strain in any direction upon the carrier. 25

The loosely or hingedly connected sections adapt the carrier to pass freely over irregularities in the surface of the soil without 30 straining the parts of the device.

Various changes in the form, proportion and minor details of construction may be resorted to without departing from the spirit or sacrificing any of the advantages thereof.

Having thus described my invention, I 35 claim—

The herein described cotton sack carrier comprising front and rear detachably connected sections having transverse braces or cleats, and parallel longitudinal strips secured to said braces or cleats, the outer or remote ends of the sections being rounded and provided with curved guard strips 20, supporting wheels mounted in bearings on the transverse center of the carrier, and casters 45 connected to the carrier near its extremities, the connections between the adjacent ends of the sections consisting of eye bolts 16 on the end of one section and adjustable hooks 18 on the end of the other section, said 50 adjustable hooks being held in place by nuts, substantially as specified.

In testimony that I claim the foregoing as my own I have hereunto affixed my signature in the presence of two witnesses.

CALVIN L. JOHNS.

Witnesses:

JAS. YOUNG,
G. H. GRAHAM.