

(19) World Intellectual Property Organization
International Bureau



(43) International Publication Date
6 February 2003 (06.02.2003)

PCT

(10) International Publication Number
WO 03/010999 A2

- (51) International Patent Classification⁷: H05B 1/02, (US). HAW, Michael, F.; 3240-1H Lynn Ridge, Raleigh, NC 27613 (US).
3/26, 3/28
- (21) International Application Number: PCT/US02/23022 (74) Agents: FISHMAN, Bella et al.; Varian, Inc., Legal Department, 3120 Hansen Way, D-102, Palo Alto, CA 94304 (US).
- (22) International Filing Date: 19 July 2002 (19.07.2002)
- (25) Filing Language: English (81) Designated State (national): JP.
- (26) Publication Language: English (84) Designated States (regional): European patent (AT, BE, BG, CH, CY, CZ, DE, DK, EE, ES, FI, FR, GB, GR, IE, IT, LU, MC, NL, PT, SE, SK, TR).
- (30) Priority Data:
09/911,103 23 July 2001 (23.07.2001) US
- (71) Applicant: VARIAN, INC. [US/US]; 3120 Hansen Way, D-102, Palo Alto, CA 94304 (US).
Published:
— without international search report and to be republished upon receipt of that report
- (72) Inventors: FERNANDO, C., J., Anthony; 1002 Grandover Drive, Durham, NC 27713 (US). SWON, James, E.; 39506 Glenn Glade, Chapel Hill, NC 27514
For two-letter codes and other abbreviations, refer to the "Guidance Notes on Codes and Abbreviations" appearing at the beginning of each regular issue of the PCT Gazette.

(54) Title: WATERLESS VESSEL HEATING SYSTEM AND METHOD

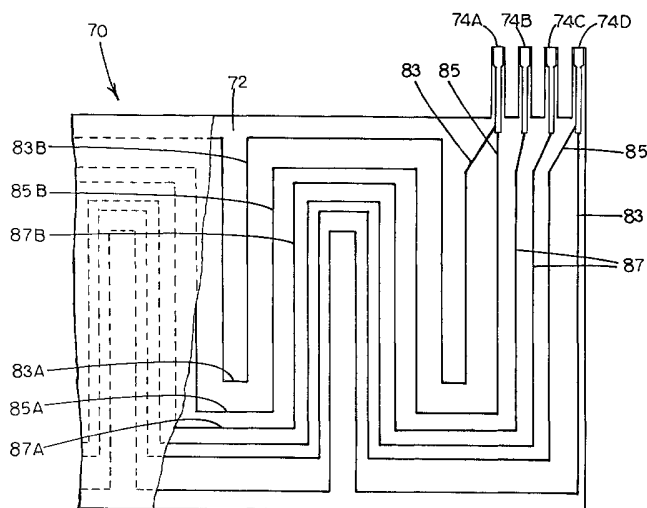

(57) Abstract: A dissolution testing system comprises a vessel plate on which a plurality of vessels are mounted. Each vessel includes a lateral wall having an outer surface around which a plurality of flexible heater elements are attached. Each heater element includes a transparent surface area, a heat conductive element extending along the transparent surface area, a temperature sensing element extending along the transparent surface area, and an electrical contact element connected to the heat conductive element and the temperature sensing element. The heater element can have more than one heating zone, with at least one of the heating zones being selectively energizable. The transparent heater element allows unobstructed view into the interior of its vessel, and reduces the time required to achieve a stabilized set point temperature in the vessel. A heater control system communicates with each heat conductive element and each temperature sensing element through a corresponding one of the electrical contact elements. The heater control system permits each vessel to be controlled independently of the other vessels.



WO 03/010999 A2

WATERLESS VESSEL HEATING SYSTEM AND METHOD**FIELD OF THE INVENTION**

The present invention relates to the preparation or testing of heated sample media contained in vessels and, more particularly, to the controlled heating of sample media in the vessels without the use of a water bath.

BACKGROUND OF THE INVENTION

In the pharmaceutical industry, the controlled heating of sample media in vessels is an important step in sample preparation procedures. Examples of such procedures include those performed for the purpose of testing and analyzing the rate at which dosages release from pharmaceutical products such as tablets, filled capsules or transdermal patches. The dosages are released in solutions under controlled conditions which may or may not be representative of the human digestive process, contact with the skin, or implantation within the body. The procedural steps, test duration, dissolution medium, and apparatus employed in any given dissolution test must comply with United States Pharmacopeia (USP) guidelines in order for the test to be accepted as valid for the specific dosage or delivery system tested.

For instance, the general requirements of Section 711 (Dissolution) of USP 23-NF18, Ninth Supplement, November 15, 1998, specify a particular apparatus, termed "Apparatus 1," which includes a covered vessel made of plastic, glass or other inert, transparent material that does not absorb, react, or interfere with the specimen being tested; a motor; a metallic drive shaft; and a cylindrical basket. Other devices may be specified from time to time for stirring, mixing or retaining the delivery system during the test procedure.

The vessel may be cylindrical with a hemispherical or flat bottom and sides which are flanged at the top. The dimensions of the vessel are specified according to the nominal volumetric capacity of the vessel. A fitted cover can be used to retard evaporation from the vessel and, when used, must provide sufficient openings to allow the ready insertion of a thermometer and withdrawal of specimens. Also included are requirements for the dimensions, construction material, position in relation to the vessel, and performance of the shaft and other operative components. Importantly, the vessel must be either partially immersed in a water bath or placed in a heating jacket to hold the temperature inside the vessel at 37 ± 0.5 °C or other specified temperature. When using a water bath, the bath fluid must be kept in constant, smooth motion.

Figure 1 illustrates a conventional dissolution testing apparatus generally designated **10**. Apparatus **10** includes a main housing or head **12** containing a programmable systems control module. Head **12** is situated above a vessel plate **14** and a water bath container **16**, and is typically motor-driven for vertical movement toward and away from vessel plate **14**. Peripheral elements located on head **12** include an LCD display **18** for providing menus, status and other information; a keypad **21** for providing user-inputted operation and control of spindle speed, temperature, test start time, test duration and the like; and readouts **23** for displaying information such as RPM, temperature, elapsed run time, or the like. Water must be heated and circulated through water bath container **16** by means such as external heater and pump modules (not shown), which may be combined into a single heater/circulator module. Water bath container **16** thus requires a fluid transfer means such as tubing **25**, as well as a drain line **27** and valve **29**.

Vessel plate **14** supports a plurality of vessels **31** extending into the interior of water bath container **16**. Typically, three, four, six or eight vessels **31** can be supported. Each vessel **31** has a standard shape characterized by a lateral cylindrical section **31A**, a bottom hemispherical (or flat) section **31B**, and a flanged section **31C** around the mouth of vessel **31**. Vessels **31** are locked and centered in place on vessel plate **14** by means such as ring lock devices or clamps (not shown). A stirring element including a motor-driven spindle **37A** and paddle **37B** operates in each vessel **31**. Individual clutches **39** can be provided to alternately engage and disengage power to each spindle **37A**. A dosage delivery module **41** is used to preload and drop dosage units (e.g., tablets) into each vessel **31** at prescribed times and bath (or vessel) temperatures. An automated sampling manifold **45** lowers and raises sampling cannulae **47** into and out of each respective vessel **31**. Sampling manifold **45** can also be vertically movable between head **12** and vessel plate **14**. Sampling cannulae **47** operate in conjunction with a bidirectional peristaltic pump (not shown), and are used during the dissolution testing procedure to periodically withdraw samples from the vessel media for analysis. Samples could also be taken manually using pipettes and/or sampling cannula/syringe assemblies. Miniature temperature probes **49** associated with each vessel **31** can also be located on sampling manifold **45**.

In a typical operation, dosage units are dropped into the bottoms of each solution-containing vessel **31** and each paddle **37B** rotates at a predetermined rate and duration within the test solution as the dosage units dissolve. In other types of tests, a cylindrical basket (not shown) loaded with a dosage unit is substituted for each paddle **37B** and rotates within the test solution. For any given vessel **31**, the temperature of the test solution must be maintained at a prescribed temperature (e.g., 37 °C). Solution temperature is maintained by immersion of vessel **31** in the water bath of water bath container **16**. Accordingly, the temperature of the test

solution is dependent upon, and thus indirectly controlled by, the temperature of the water bath which in turn is dictated by the external heating means employed. Temperature probe 49 is used to monitor the test solution temperature, and can be any suitable type of transducer such as a thermistor.

5 As recognized by those skilled in the art, the use of a water bath in connection with an apparatus such as dissolution testing apparatus 10 has some drawbacks. First, water bath container 16 is necessarily large in order to accommodate the immersion of several vessels 31, and hence requires a significant volume of water to serve as the medium for transferring heat energy to the media or solution contained in vessels 31. Consequently, an undue amount of time
10 and energy is required to initially dispense the volume of heated water into water bath container 16 and bring each vessel 31 to the desired set point temperature. The volume of water also adds to the overall weight of apparatus 10. Second, an external heater and water circulation system is required. It might be possible to eliminate the water circulation system by providing an external resistive heating plate or coil to heat the water bath. Such a resistive heating element, however,
15 would necessarily be quite large in order to heat the entire volume of the water bath, require a large amount of electrical energy to operate, and would not appreciably reduce the amount of startup time required to bring vessels 31 to a desired set point temperature. Third, the water bath system does not allow for individualized control of each vessel 31. The ability to control the heating profile of a given vessel 31 or group of vessels 31 independently and distinct from other
20 vessels 31 of dissolution testing apparatus 10 would be quite useful during many types of procedures. Fourth, biological growth, scaling, and other impurities tend to collect in the water bath, such that the use of the water bath entails cleaning maintenance and the addition of preservatives or additives, all of which adds to the cost of the water bath system.

One approach to eliminating the need for a water bath and controlling the temperatures
25 of individual vessels, while still conforming to USP dissolution requirements, is disclosed in U.S. Patent No. 5,589,649 to Brinker et al. The embodiments disclosed therein provide individual flexible, resistive heater elements attached to and wrapped around the lateral cylindrical section of the outside wall of each vessel. Each heater element is divided into horizontally-oriented upper and lower heating areas having differing power ratings (e.g., 100W,
30 200W, etc.). The heating areas are controlled by the associated dissolution testing apparatus through lead wires. Lead wires are provided separately for each heating area and are connected directly to the controller section of the apparatus. Accordingly, each heater element taught by Brinker et al. in effect contains two heating devices or elements. Each heater element is required to be held in place on its vessel by a spring-loaded stainless steel jacket. The jacket is profiled

to provide a gap between the jacket and the heater element. Because the vessel is not immersed in a heat-providing water bath, a reflective coating is attached to the hemispherical section of the vessel in order to reduce heat loss from the vessel and reduce the time required to bring the test solution to the desired solution temperature.

5 The temperature control system disclosed in Brinker et al. requires the use of a modified stirring element for each vessel. The shaft of the modified stirring element is hollow. A temperature sensor such as a resistive thermal device (RTD), thermocouple or thermistor is located near the bottom of the hollow interior of the stirring element shaft in physical thermal contact therewith, and generates signals representative of temperature measured within the
10 vessel. Power to this temperature sensor and the signals generated thereby are transmitted through a cable running through the hollow length of the stirring element shaft, through a signal transfer device located at the top of the shaft, and through a second cable connected to the control circuitry of the dissolution testing apparatus.

 The requisite jacket is disadvantageous in that it impairs or, in some cases, almost
15 completely obstructs a view of the contents of the vessel and the stirring element operating therein. This problem is especially critical in view of the fact that USP Section 711 expressly indicates that the dissolution apparatus should preferably permit observation of the specimens and stirring element during testing. Moreover, the jacket does not completely insulate the vessel from external thermal influences such as room air conditioning, heating, ventilation, and open
20 doors. In addition, the customized stirring element and its requisite electrical components, as well as the need for the addition of a reflective coating, are believed to be unduly complex and expensive solutions to the problems presented by current vessel heating systems.

 Accordingly, there remains a need for a more practical, effective, and energy efficient solution to providing a vessel heating system that does not require a water bath and that can
25 independently control individual vessels in a vessel-containing system such as a dissolution testing apparatus. The present invention is provided to address these and other problems associated with vessel heating systems.

SUMMARY OF THE INVENTION

30 According to one aspect of the present invention, a heater element comprises a plurality of clear, flexible films, a temperature sensing element, and a heat conductive element. The temperature sensing element is interposed between the films, and includes an elongate temperature sensing portion extending over a surface area of the heater element along a first alternating, serpentine course. The heat conductive element is also interposed between the films,

and includes an elongate heat conductive portion extending over the surface area of the heater element along a second alternating, serpentine course adjacent to the first course. An electrical contact element is connected to the heat conductive element and the temperature sensing element.

5 In one embodiment, the heater element includes an internal adhesive. The temperature sensing element is adhered to a first side of the internal adhesive, and the heat conductive element is adhered to a second side of the internal adhesive.

 In another embodiment, the heater element includes three films. The temperature sensing element is interposed between the first and second films, and the heat conductive
10 element is interposed between the second and third films.

 In yet another embodiment, the heater element comprises a plurality of films, including a first film and a second film. The temperature sensing and heat conductive elements are interposed between the first film and the second film.

 In a further embodiment, the heater element comprises a first heating zone and a second
15 heating zone. The heat conductive element has at least one portion running through the first heating zone, and at least one other portion running through the second heating zone. A common electrical contact interconnects the first and second heating zones. In use, depending on the level of liquid to be heated in a vessel to which the heater element is attached, either one or both heating zones is energized to provide dissipative heat. Preferably, the temperature
20 sensing element extends through only one of the heating zones, e.g., the heating zone that operates regardless of liquid level.

 According to another aspect of the present invention, a heater element comprises a plurality of clear, flexible films, a temperature sensing element, a heat conductive element, and an electrical contact element connected to the heat conductive element and the temperature
25 sensing element. The temperature sensing element and the heat conductive element are each interposed between the films. The temperature sensing element includes an elongate temperature sensing portion, which extends over a surface area of the heater element and defines an embedded wire pattern.

 According to yet another aspect of the present invention, a vessel heating system
30 comprises a vessel and a flexible heater element. The vessel includes a lateral wall having an outer surface to which the heater element is attached. The heater element includes a transparent surface area, a heat conductive element extending along the transparent surface area, a temperature sensing element extending along the transparent surface area, and an electrical contact element connected to the heat conductive element and the temperature sensing element.

In one embodiment, the heater element is adhered to the vessel using a pressure-sensitive adhesive.

In another embodiment, the heater element is baked directly onto the vessel using a suitable adhesive.

5 In a further embodiment, the vessel extends into a transparent vessel isolation chamber, such that the heater element is interposed between the vessel and the vessel isolation chamber and an annular gap adjacent to the heater element is defined between the vessel and the vessel isolation chamber.

10 In a still further embodiment, the vessel is mounted to a vessel plate. A set of plunger contacts, also mounted to the vessel plate, are connected to the electrical contact element.

According to a further aspect of the present invention, a dissolution testing system comprises a vessel plate, a plurality of vessels mounted to the vessel plate, a plurality of heater elements, and a heater control system. Each vessel includes a lateral wall having an outer surface to which a corresponding heater element is attached. Each heater element includes a transparent surface area, a heat conductive element extending along the transparent surface area, a temperature sensing element extending along the transparent surface area, and an electrical contact element connected to the heat conductive element and the temperature sensing element. The heater control system communicates with each heat conductive element and each temperature sensing element through a corresponding one of the electrical contact elements.

20 The present invention also provides a method for heating a vessel without the use of a fluid heating medium. A flexible heater element is provided around a circumference of a vessel. The heater element includes a transparent surface area, a heat conductive element extending along the transparent surface area, a temperature sensing element extending along the transparent surface area, and an electrical contact element connected to the heat conductive element and the temperature sensing element. A substance is dispensed into the vessel, and a temperature probe is extended into the substance. Electrical power is supplied to the heat conductive element to cause heat energy to transfer into the substance. Electrical power is also supplied to the temperature sensing element. The temperature probe is used to monitor the temperature of the substance as the substance is heated by the heat conductive element, and to determine when the substance has reached a predetermined set point temperature. A value measured by the temperature sensing element, and which corresponds to the set point temperature, is read. That value is used to maintain the set point temperature.

25

30

It is therefore an object of the present invention to provide a vessel heating system that does not rely on a water bath to control and maintain the temperature of a test solution contained in a vessel.

It is another object of the present invention to provide a vessel heating system that is able
5 to independently control individual vessels of a vessel-containing apparatus.

It is a further object of the present invention to provide a vessel heating system that reduces the startup time required for bringing the solution or media contained in one or more vessels to a stabilized, prescribed set point temperature.

Some of the objects of the invention having been stated hereinabove, other objects will
10 become evident as the description proceeds when taken in connection with the accompanying drawings as best described hereinbelow.

BRIEF DESCRIPTION OF THE DRAWINGS

Figure 1 is a perspective view of a conventional dissolution testing apparatus equipped
15 with a water bath heating system;

Figure 2 is a vertical cross-sectional view of a vessel provided according to the present invention;

Figure 3 is a front elevation view of a heater element provided according to the present invention;

20 Figure 4A is a perspective view of a plunger contact element provided in accordance with the present invention;

Figure 4B is another perspective view of the plunger contact element illustrated in Figure 4A;

25 Figure 5 is a detailed front elevation view of a portion of the heater element illustrated in Figure 3;

Figure 6 is a front elevation view of an alternative heater element provided according to the present invention;

Figure 7 is a vertical cross-sectional view of a heater element provided according to the present invention;

30 Figure 8 is a vertical cross-sectional view of an alternative heater element provided according to the present invention;

Figure 8A is a detailed vertical cross-sectional view of an operative portion of the heater element illustrated in Figure 8;

Figure 9 is a perspective view of a dissolution testing apparatus equipped with a vessel heating system according to the present invention;

Figure 10 is a schematic diagram of operative elements included in a vessel heating system according to the present invention;

5 Figure 11 is a front elevation view of a heater element provided according to another embodiment of the present invention; and

Figure 12 is a vertical cross-sectional view of a heater element according to an another embodiment of the present invention.

10 DETAILED DESCRIPTION OF THE INVENTION

Referring to Figure 2, a vessel generally designated **60** is provided as part of a waterless vessel heating system in accordance with the present invention. The design of vessel **60** makes it particularly suited for use in conjunction with many types of dissolution testing apparatuses such as, for example, apparatus **10** shown in Figure 1. Vessel **60** is a modification of a standard
15 USP vessel having a lateral cylindrical section **60A**, a bottom hemispherical section **60B**, and a flanged section **60C**. A flexible heater element generally designated **70** is attached to the outer surface of cylindrical section **60A**. Heater element **70** extends around the entire circumference of cylindrical section **60A**. Test data gathered by the inventors have shown that, when vessel **60** is provided with heater element **70** of the present invention, hemispherical section **60B** does not
20 need to be heated. This is due in part to the fact that a primary operation of the dissolution testing apparatus is to stir the media contained in vessel **60**. This stirring or agitation largely occurs in the interior portion of vessel **60** adjacent to hemispherical section **60B**. The rate of heat energy transferred into the vessel media by heater element **70** is sufficiently high that, when combined with the energy added by the stirring element, heat loss from hemispherical section
25 **60B** is insignificant.

Additionally, in the present invention a clear plastic or glass vessel isolation chamber wall **62** is mounted to the underside of a modified vessel plate **64**. Vessel isolation chamber wall **62** encloses vessel **60** such that an insulating air gap or air barrier **66** is defined between the respective walls of vessel **60** and vessel isolation chamber **62**. Test data have shown that air gap
30 **66** has a positive effect in maintaining vessel media temperature and isolating vessel **60** and the media contained therein from external thermal influences.

Referring to Figure 3, heater element **70** is shown in uninstalled planar form. Heater element **70** includes a heater area **72** circumscribed by lateral edges **70A** and **70B**, a top edge **70C**, and a bottom edge **70D** of heater element **70**. Heater element **70** also includes a set of

contacts **74** to provide electrical communication between the operative components of heater area **72** and the control system provided with the present invention, to be described below. In this embodiment, contact set **74** includes four electrically conductive contact elements **74A-74D**, which can be provided in the form of flat or cylindrical plates or strips. As described below, heater area **72** includes both heat conductive and temperature sensing elements. In addition, heater area includes a protective sensor **81** such as a thermistor, which is embedded within heater area **72** and serves as a preventative device in the event of a control system malfunction.

Referring to Figures 4A and 4B, a contact block **75** is utilized to make electrical contact with contact set **74**. As shown in Figure 2, contact block **75** is mounted in vessel plate **64**. A set of four stainless steel, gold-plated, spring-loaded plunger contacts **77A-77D** protrude from an upper surface **75A** of contact block **75**. Contact set **74** is preferably situated at the underside of flanged section **60C** of vessel **60**. Consequently, when vessel **60** is installed in vessel plate **64**, contact elements **74A-74D** are pressed into contact with corresponding plunger contacts **77A-77D**. A lower surface **75B** of contact block **75** includes connective features **79A-79D** for enabling electrical communication with the control system associated with the present invention.

It can be seen from Figure 2 that contact block **75** is mounted in a fixed position in vessel plate **64**. With respect to the aperture of vessel plate **64** through which vessel **60** is installed, the position of contact block **75** is fixed both radially and circumferentially. As a result, vessel **60** will always be installed in the same location and orientation in vessel plate **64**, even after being removed and reinstalled. This is because, in this particular embodiment, installation requires that contact elements **74A-74D** of heater element **70** be aligned with plunger contacts **77A-77D** of contact block **75**. Therefore, the use of contact block **75** enhances the consistency and repeatability of the orientation of vessel **60**.

Referring to the detail view of Figure 5, heat conductive elements **83** and **85** and temperature sensing elements **87** are provided in heater area **72** in the form of a serpentine, alternating wire pattern connected to contact elements **74A-74D** and running along substantial portions of the length and height of heater area **72**. Accordingly, when heater element **70** is viewed in the planar form illustrated in Figures 3 and 5, the course traveled by heat conductive elements **83** and **85** is adjacent to the course traveled by temperature sensing elements **87**. Heat conductive elements **83** and **85** are preferably heat conductive wires and temperature sensing element **87** is preferably a temperature sensing wire. Moreover, heat conductive elements **83** and **85** are preferably constructed from a good resistive heat dissipating material such as copper, and temperature sensing element **87** is preferably an RTD in wire form.

Heat conductive elements **83** and **85** each run from first contact element **74A** along an alternating course toward lateral edge **70A** of heater element **70** (see Figure 3) and return to fourth contact element **74D** to complete the heater circuit. Similarly, temperature sensing element **87** runs from second contact element **74B** along an alternating course between heat conductive elements **83** and **85** toward lateral edge **70A**, and returns to third contact element **74C** to complete the temperature sensing circuit. It can be seen that heat conductive elements **83** and **85** and temperature sensing element **87** each have several respective horizontally oriented sections **83A**, **85A** and **87A** and vertically oriented sections **83B**, **85B** and **87B**. By this design, heat conductive elements **83** and **85** are uniformly distributed over heater area **72** for uniform heat transfer from heater element **70** to the media in vessel **60**, and temperature sensing element **87** is uniformly distributed over heater area **72** in order to effectively sense an average temperature of heater element **70** (and thus vessel **60**). While Figure 5 illustrates an embodiment wherein vertically oriented sections **83B**, **85B** and **87B** are the dominant lengths, it will be understood that the wire pattern could be configured such that horizontally oriented sections **83A**, **85A** and **87A** are the dominant lengths. Furthermore, heat conductive elements **83** and **85** and temperature sensing elements **87** could include sections that are angled with respect to the horizontal or the vertical. Such alternative wire patterns can also result in uniform distribution over heater area **72**.

Preferably, heat conductive elements **83** and **85** and temperature sensing elements **87** each have continuous lengths throughout heater area **72**. However, the number of heat conductive elements **83** and **85** and temperature sensing elements **87**, as well as the number of contact elements **74A-74D**, are not limited by the present invention to the illustrated embodiments.

In one exemplary embodiment, heater element **70** is 13.1 inches long and 3.875 inches high. The total heater power output delivered is 120 W during operation at a supply voltage of 48 VDC and a current of 3.0 A. Heat conductive elements **83** and **85** have a resistance of 17.6 Ω at 25 °C. Temperature sensing element **87** is rated at 1000 Ω averaged over heater area **72**. Thermistor **81** is rated at 2.252 k Ω .

Referring to Figure 6, an alternative heater element generally designated **90** includes a contact set **94** in the form of "pigtails" in which lead wires **94A-94D** are substituted for contact elements **74A-74D** shown in Figure 3. The serpentine, alternating wire pattern defined by heat conductive elements **83** and **85** and temperature sensing elements **87** can be designed similar to that shown in Figure 5.

Heater element **70** (or **90**) provided in accordance with the present invention is characterized in that it is flexible and thin. In addition, heater element **70** is highly transparent so as not to impair observation of the vessel media, test substance and the various components operating within vessel **60**, such as the stirring element, temperature probe, sample cannula and the like. Accordingly, heater element **70** is constructed as a clear laminate as shown in the cross-sectional views of Figures 7 and 8.

Referring to Figure 7, heater element **70** (or **90**) is constructed by applying temperature sensing element **87** to a clear polymeric film **101**, applying heat conductive elements **83** and **85** to a clear polymeric film **103**, and applying an additional clear polymeric film **105** to heat conductive elements **83** and **85**. As a result, temperature sensing element **87** is sandwiched between films **101** and **103** and heat conductive elements **83** and **85** are sandwiched between films **103** and **105**. The resulting laminate is then secured to the wall of vessel **60** with a suitable pressure-sensitive adhesive **107** such as a high-performance type available from 3M.

Referring to Figures 8 and 8A, a more preferable construction for heater element **70** (or **90**) is illustrated. A composite **110** is sandwiched between two polyester films **114** and **116**. As shown in Figure 8A, the composite **110** is formed by applying temperature sensing element **87** and heat conductive elements **83** and **85** to either side of an internal adhesive **112**, such as a high-performance type available from 3M. The resulting laminate is baked directly onto the wall of vessel **60** by employing a polyethylene adhesive **118** such as a high-performance type available from 3M.

Referring to Figure 9, a dissolution testing apparatus generally designated **130** is provided in accordance with the present invention. A plurality of modified vessels **60** equipped with heater elements **70** (or **90**) and vessel isolation chambers **62** are installed in modified vessel plate **64**. Sampling manifold **45** preferably is capable of lowering all temperature probes **49** into their respective vessels **60** simultaneously or lowering an individual temperature probe **49** into its vessel **60** apart from other temperature probes **49**. With the use of modified vessels **60**, the water bath system shown in Figure 1 is not needed. Other features and components of dissolution testing apparatus **130** can be generally similar to those described in connection with Figure 1.

Figure 10 is a general schematic diagram of a waterless vessel heating control system generally designated **150** provided in accordance with the present invention to operate in conjunction with an apparatus such as dissolution testing apparatus **130** equipped with one or more vessels **60**. Heating system control circuitry or controller **155** is adapted to communicate with main control circuitry **160** of dissolution testing apparatus **130** over a dedicated

communication link **162**, and hence can be housed within main head **12** of such apparatus **130**. Preferably, controller **155** operates according to a set of instructions provided by system software, and therefore controller **155** and/or main control circuitry **160** include appropriate memory, logic and interface components as understood by those skilled in the art. Controller

5 **155** independently operates heat conductive elements **83** and **85** of each vessel **60** by controlling the power supplied thereto. Controller **155** also powers and receives signals from temperature sensing element **87** as well as protective sensor **81** provided with each heater element **70**. Controller **155** further communicates with each temperature probe **49** associated with each vessel **60**. Element **164** represents means such as a keypad for enabling user input of vessel

10 media set point temperature and other appropriate system parameters for each vessel **60**. Element **166** represents a device for displaying temperature and other information pertinent to the vessel heating process.

It therefore can be seen that control system **150** is able to simultaneously and individually control and maintain each vessel **60** at a given temperature, with an observed

15 accuracy of ± 0.1 °C, and permits each vessel **60** to be set at a different temperature if desired. Moreover, control system **150** is configured to minimize initial startup time of each heated vessel **60**. For instance, the startup time required to bring the media in a 900-mL vessel from room temperature to a stabilized set point temperature of about 37 or 38 °C has been observed to be approximately less than 9 minutes, which represents a significant improvement over water

20 bath systems. Control system **150** is further characterized by its use of three temperature sensors per vessel **60**. Specifically, temperature probe **49** is used for monitoring of startup conditions and instantaneous monitoring of vessel media temperature after stabilization. Temperature sensing element **87** is used for controlling heater element/vessel temperature and thus ultimately controlling vessel media temperature. Protective sensor **81** is preferably a thermistor used as a

25 safety measure to prevent heater element **70** from self-destructing in the event of a malfunction.

Referring now to Figure 11, a heater element generally designated **170** is shown in uninstalled planar form according to another embodiment of the invention. In this embodiment, heater element **170** includes a plurality of heater zones or areas **172A** and **172B** circumscribed by lateral edges **170A** and **170B**, a top edge **170C**, and a bottom edge **170D** of heater element

30 **170**. In the specific embodiment illustrated in Figure 11, heater element **170** includes an upper heater area **172A** and a lower heater area **172B** so as to be in thermal contact with upper and lower portions of a vessel **60**, respectively. Contact set **174** includes at least one additional contact element, when compared to the embodiment illustrated in Figure 3. Thus, for example, contact set **174** in Figure 11 includes five electrically conductive contact elements **174A-174E**,

which can be provided in the form of flat or cylindrical plates or strips (or with profiles having both flat and cylindrical elements). One of contact elements **174A-174E** serves as a common connection between upper heater area **172A** and a lower heater area **172B** and thus serves as a center tap. At least one other contact element **174A-174E** is connected to upper heater area **172A**, and at least one other contact element **174A-174E** is connected to lower heater area **172B**. With the use of the center tap and thus the localized, common connection between upper heater area **172A** and lower heater area **172B**, heater element **170** of Figure 11 remains essentially a single heating device but with two distinct heating zones. If used in conjunction with heater element **170** of Figure 11, contact block **75** illustrated in Figures 4A and 4B is modified to include the appropriate number of plunger contacts necessary for connection with contact elements **174A-174E**.

With analogous reference to Figure 5, the heat conductive elements provided in both upper heater area **172A** and lower heater area **172B** are preferably one or more wires that run along serpentine courses to cover a substantial portion of upper and lower heater areas **172A** and **172B**, respectively. In the present configuration, one of the heat conductive elements runs between upper and lower heater areas **172A** and **172B** through that contact element **174A-174E** serving as the center tap. By this configuration, the energization of one or both of heater areas **172A** and **172B** can be easily and quickly controlled. For example, if a vessel **60** contains 900 mL of dissolution media, contact set **174** will be energized so that electrical current runs through the heat conductive elements of both upper and lower heater areas **172A** and **172B**. If, on the other hand, vessel **60** contains 500 mL of dissolution media, contact set **174** will be energized so that electrical current runs through the heat conductive element or elements of only lower heater area **172B**.

Heater element **170** of Figure 11 also includes temperature sensing elements, such as temperature sensing elements **87** shown in Figure 5, which are preferably in the form of an RTD connected to two of contact elements **174A-174E**. This temperature sensing element (or elements) runs along a temperature sensing area **185** that is situated within lower heater area **172B** in the sense of being radially adjacent thereto, since lower heater area **172B** operates regardless of the volume of dissolution media in vessel **60** to be heated. In addition, heater element **170** can include one or more protective sensors, such as shown in Figure 5, which is embedded within either or both of upper and lower heater areas **172A** and **172B**. It will be further noted that heater element **170** can operate in connection with dissolution test apparatus **130** illustrated in Figure 9. Additionally, control system **150** described hereinabove with reference to Figure 10 can be programmed through user input to select whether one or both of

heater areas **172A** and **172B** is to be operational during use of the invention, such as by allowing the user to specify the volume of the contents of the vessel or vessels **60** to be heated.

In one example corresponding to the embodiment illustrated in Figure 11, heater element **170** is 13.0 inches long and 3.0 inches high. The total heater power output delivered is 160 W.

5 Heater element **170** could be configured, for example, such that 80 W of power are delivered to upper heater area **172A** and 80 W delivered to lower heater area **172B**.

Referring to Figure 12, a suitable construction of heater element **170** is illustrated. This construction comprises a polymeric (e.g., polyester) film **181**; an adhesive layer or application **183**; a layer **185** representing the heat conductive and temperature sensing elements respectively
10 disposed in upper heating area **172A**, lower heating area **172B**, and temperature sensing area **185**; another polymeric film **187** disposed on the other side of layer **185**; and another adhesive layer or application **189**. The resulting laminate is attached to the wall of vessel **60**. The construction illustrated in Figure 12 could also serve as an alternative to the constructions illustrated in Figures 7, 8 and 8A for heater elements **70** and **90**. Likewise, heater element **170**
15 could be implemented in the constructions shown in Figures 7, 8 and 8A.

In operation, and using heater elements **70**, **90** or **170** according to any of the embodiments described herein, the software of control system **150** upon startup initiates a vessel self-test routine, which checks each vessel **60** for proper electrical contact and installation in vessel plate **64**. Preferably, this is accomplished by applying a voltage to each heater element **83**
20 and **85** for a very short time and measuring the voltage drop across an in-line resistor. After the vessel self-test routine is completed, the status of each vessel **60** is displayed (e.g., "OK" or "FAIL"). This vessel self-test routine is preferably accessible at any time by the user of dissolution testing apparatus **130** for on-the-fly diagnostic purposes. In order to afford the user the option of setting different operating temperatures for each vessel **60** or each group of vessels
25 **60**, the software preferably prompts the user to either "SET ALL" or "SET INDIVIDUAL" vessel temperatures. If the SET ALL option is selected, the user will be prompted to enter the value for a single set point temperature, and that value will be utilized by controller **155** to control all vessels **60** installed on vessel plate **64**. If the SET INDIVIDUAL option is selected, the user will be prompted to enter a set point temperature value for each individual vessel **60**
30 operating in apparatus **130**.

When the vessel heating system is then turned ON, controller **155** conducts an appropriate amount of power to heat conductive elements **83** and **85** of each heater element **70** in accordance with the set point value entered for corresponding vessel **60**. Head **12** of dissolution testing apparatus **130** moves down toward vessel plate **64** and sampling manifold **45** lowers each

temperature probe 49 down into the media of each vessel 60. At this stage, controller 155 utilizes each temperature probe 49 as the primary sensor and initial source for control of vessel 60 into which respective temperature probe 49 is lowered. Temperature probes 49 send signals to controller 155 indicative of the media temperatures measured in respective vessels 60, such that controller 155 monitors the rise in media temperature in each vessel 60.

Controller 155 determines that the media temperature in a given vessel 60 has stabilized at the previously inputted set point based on an appropriate condition written into the software. Preferably, controller 155 determines the occurrence of stabilization when controller 155 reads a series of media temperature values from a given temperature probe 49 that deviate less than ± 0.05 °C from the set point value previously established for that vessel 60 over a 10 second period.

Once controller 155 determines that the media temperature in a particular vessel 60 has stabilized at the programmed set point value, controller 155 in effect passes the sensory function from temperature probe 49 associated with that vessel 60 over to temperature sensing element 87 of heater element 70 corresponding to that vessel 60. The temperature value read by temperature sensing element 87 can be characterized as the vessel or heater element temperature and will be somewhat higher than, but nevertheless directly proportional to, the actual temperature value of the media contained in vessel 60. For example, if the set point value of the media is 37 °C, the value measured by temperature sensing element 87 might be 39 °C. At this point, controller 155 locks in the value measured by temperature sensing element 87, associates that value with the level of power to be distributed to corresponding heat conductive elements 83 and 85 of heater element 70, and utilizes temperature sensing element 87 as the primary control sensor. After all vessels 60 are stabilized at their respective set point temperatures and control has been switched to temperature sensing elements 87, sampling manifold 45 is moved upwardly to remove temperature probes 49 from vessels 60 and a message is displayed indicating that all vessels 60 have reached their set point temperatures.

The value measured by each temperature sensing element 87 is then utilized by controller 155 during the media sampling process to control the media temperature for that particular vessel 60. During media sampling, temperature probes 49 can be periodically employed to measure and verify the actual media temperatures. If the media temperature of a given vessel 60 is determined to be outside an appropriate error tolerance (e.g., ± 0.05 °C), controller 155 makes the adjustment to the temperature sensing element value necessary to bring the media temperature back within the prescribed limits. Protective sensor 81, upon detecting a

malfunction such as a runaway temperature condition, will send a signal to controller **155** to shut the system down.

5 It will be understood that the present invention is not limited to the specific context of dissolution testing equipment, but rather finds utility in any apparatus or procedure wherein the contents of a vessel or vessels are to undergo a controlled temperature profile.

10 It will be further understood that various details of the invention may be changed without departing from the scope of the invention. Furthermore, the foregoing description is for the purpose of illustration only, and not for the purpose of limitation--the invention being defined by the claims. It will be understood that various details of the invention may be changed without departing from the scope of the invention. Furthermore, the foregoing description is for the purpose of illustration only, and not for the purpose of limitation—the invention being defined by the claims.

WHAT IS CLAIMED IS:

1. A heater element comprising:

(a) a plurality of films;

(b) a temperature sensing element interposed between the films and including an elongate temperature sensing portion, the elongate temperature sensing portion extending over a surface area of the heater element and defining an embedded wire pattern;

(c) a heat conductive element interposed between the films; and

(d) an electrical contact element connected to the heat conductive element and the temperature sensing element.

2. The heater element according to claim 1 wherein the heat conductive element includes an elongate heat conductive portion extending over the surface area of the heater element, and the temperature sensing element and the heat conductive element cooperatively define the embedded wire pattern.

3. A heater element comprising:

(a) a plurality of films;

(b) a temperature sensing element interposed between the films and extending over a surface area of the heater element along a first alternating, serpentine course;

(c) a heat conductive element interposed between the films and extending over the surface area of the heater element along a second alternating, serpentine course adjacent to the first course; and

(d) an electrical contact element connected to the heat conductive element and the temperature sensing element.

4. The heater element according to any of claims 1 - 3 wherein the heat conductive element comprises a first heat conductive portion disposed in a first heating zone and a second heat conductive portion disposed in a second heating zone.

5. The heater element according to claim 4 wherein the first heating zone is disposed above the second heating zone and the temperature sensing element is disposed in the second heating zone.

6. A heater element comprising:

(a) a plurality of films;

(b) a heat conductive element interposed between the films and comprising a first heat conductive portion and a second heat conductive portion, the first portion extending over a first surface area of the heater element along a first alternating, serpentine course, and the second portion extending over a second surface area of the heater element along a second alternating, serpentine course;

(c) a temperature sensing element interposed between the films and comprising a temperature sensing portion extending over a third surface area of the heater element along a third alternating, serpentine course adjacent to the second course; and

(d) an electrical contact element connected to the heat conductive element and the temperature sensing element.

7. The heater element according to claim 6 wherein the third surface area is disposed within the second surface area section.

8. The heater element according to claims 4 or 6 wherein the electrical contact element includes a common contact interconnecting the first and second heat conductive portions.

9. The heater element according to claims 3 or 6 wherein the plurality of films includes a first film and a second film, the temperature sensing element is interposed between the first and second films and adhered to a first side of an internal adhesive, and the heat conductive element is interposed between the first and second films and adhered to a second side of the internal adhesive.

10. The heater element according to claims 3 or 6 wherein the plurality of films includes a first film, a second film and a third film, the temperature sensing element is interposed between the first and second films, and the heat conductive element is interposed between the second and third films.

11. A vessel heating system comprising:

(a) a vessel including a lateral wall having an outer surface; and

(b) a heater element attached to the outer surface of the lateral wall, the heater

element comprising a first heating zone and a second heating zone, a first heat conductive element disposed in the first heating zone, a second heat conductive element disposed in the second heating zone, a temperature sensing element disposed in at least one of the heating zones, and an electrical contact element connected to the first heat conductive element, the second heat conductive element, and the temperature sensing element.

5

12. The vessel heating system according to claim 11 comprising a transparent chamber wall defining a vessel isolation chamber, wherein the vessel extends into the vessel isolation chamber, the heater element is interposed between the vessel and the chamber wall, and the vessel and chamber wall cooperatively define an annular gap adjacent to the heater element.

10

13. The vessel heating system according to claim 11 comprising a vessel plate to which the vessel is mounted, and an electrical contact structure mounted to the vessel plate and connected to the electrical contact element of the heater element.

15

14. The vessel heating system according to any of claims 11 - 13 comprising a heater control circuit communicating with the first and second heat conductive elements and the temperature sensing element through the electrical contact element.

20

15. The vessel heating system according to claim 14 comprising a temperature probe extendable into an interior space of the vessel and communicating with the heater control circuit.

25

16. The vessel heating system according to claim 14 comprising a plurality of additional vessels and a plurality of corresponding additional heater elements, wherein the heater control circuit communicates with the first and second heat conductive elements of each heater element and with the temperature sensing element of each heater element.

30

17. The vessel heating system according to claim 11 comprising means for mounting the vessel in a consistent, repeatable position with respect to a vessel plate.

18. The vessel heating system according to claim 11 wherein the first heating zone is disposed above the second heating zone in relation to the lateral wall, and the temperature sensing element is disposed in the second heating zone.

19. The vessel heating system according to claim 11 comprising a common electrical contact interconnecting the first and second heat conductive elements.

5 20. The heater element according to any of claims 1, 2, 6 or 11 wherein the temperature sensing element is a resistive thermal device.

21. A method for heating a vessel without the use of a fluid heating medium comprising the steps of:

- 10 (a) providing a heater element attached to a vessel and extending around a circumference of the vessel, the heater element including a first heating zone and a second heating zone, a first heat conductive element disposed in the first heating zone, a second heat conductive element disposed in the second heating zone, and a temperature sensing element disposed in at least one of the heating zones;
- 15 (b) dispensing an amount of a substance into the vessel;
- (c) supplying electrical power to one or both of the heating zones, depending on the amount of substance dispensed into the vessel, to transfer heat energy to the substance;
- 20 (d) supplying electrical power to the temperature sensing element;
- (e) extending a temperature probe into the substance to monitor the temperature of the substance as the substance is heated by the heat conductive element, and to determine when the substance has reached a predetermined set point temperature;
- (f) reading a value measured by the temperature sensing element corresponding to the set point temperature; and
- 25 (g) using the value measured by the temperature sensing element to maintain the set point temperature.

22. The method according to claim 21 comprising the step of extending the vessel into a vessel isolation chamber to reduce the effects of external thermal influences.

30

23. The method according to claim 21 comprising the steps of mounting the vessel in an aperture of a vessel plate, the vessel plate comprising a contact block mounted thereto, and aligning the vessel in the aperture to enable the contact block to electrically communicate with

the first heat conductive element, the second heat conductive element and the temperature sensing element, whereby the vessel is disposed in a consistent, repeatable position with respect to the vessel plate.

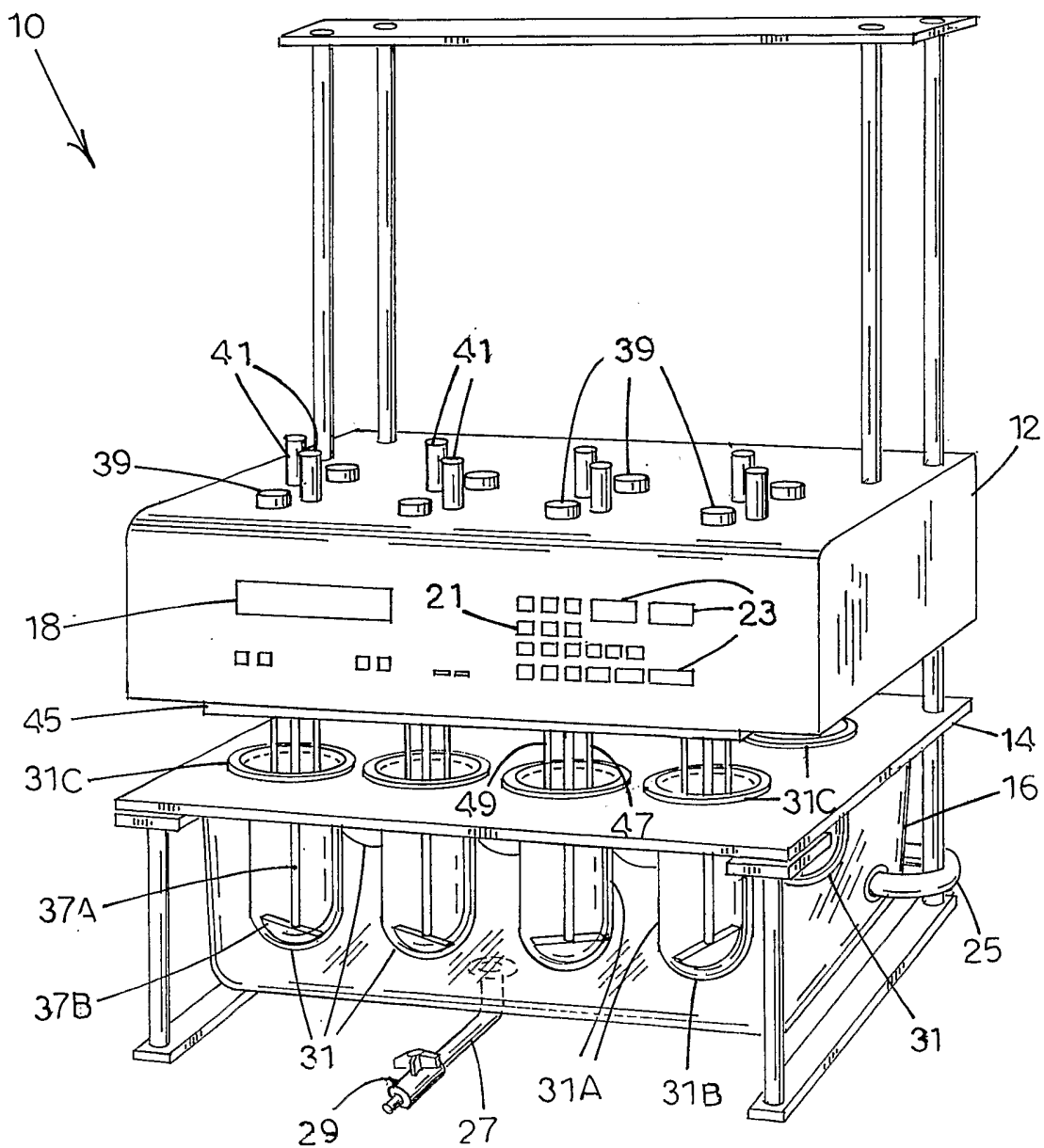

(PRIOR ART)

Fig. 1

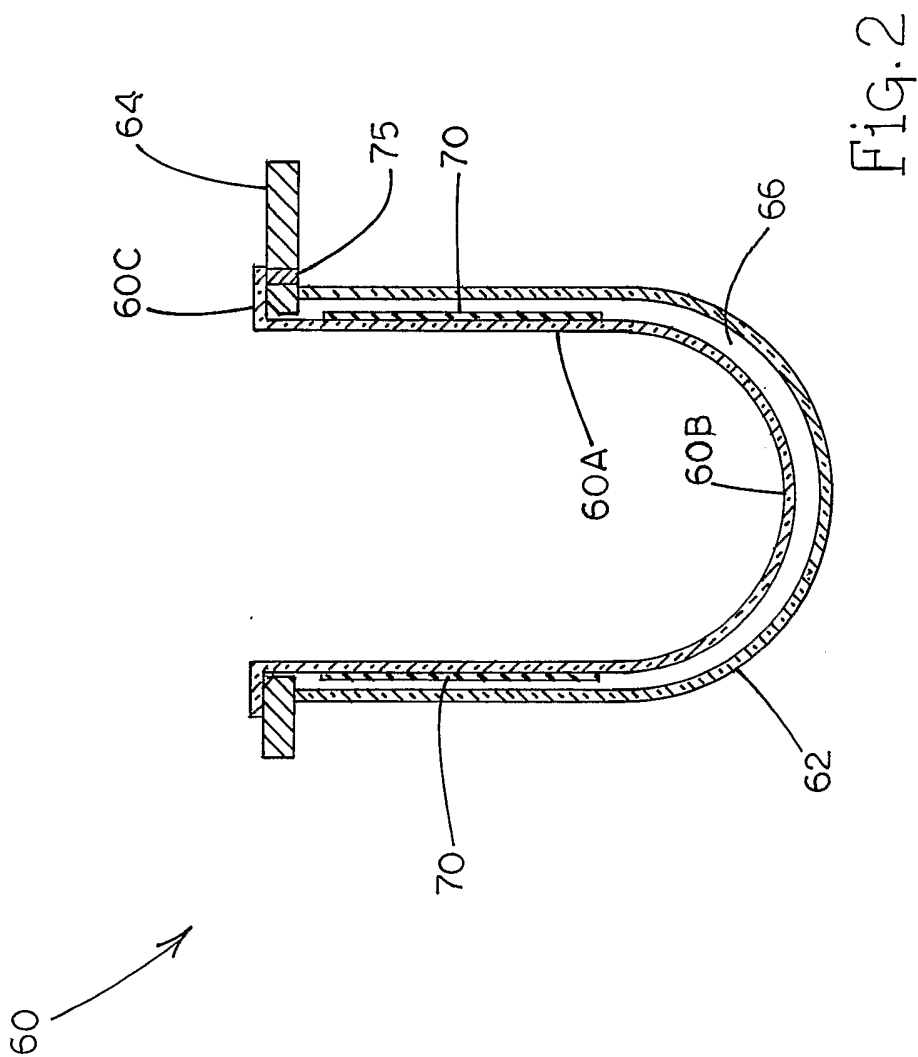

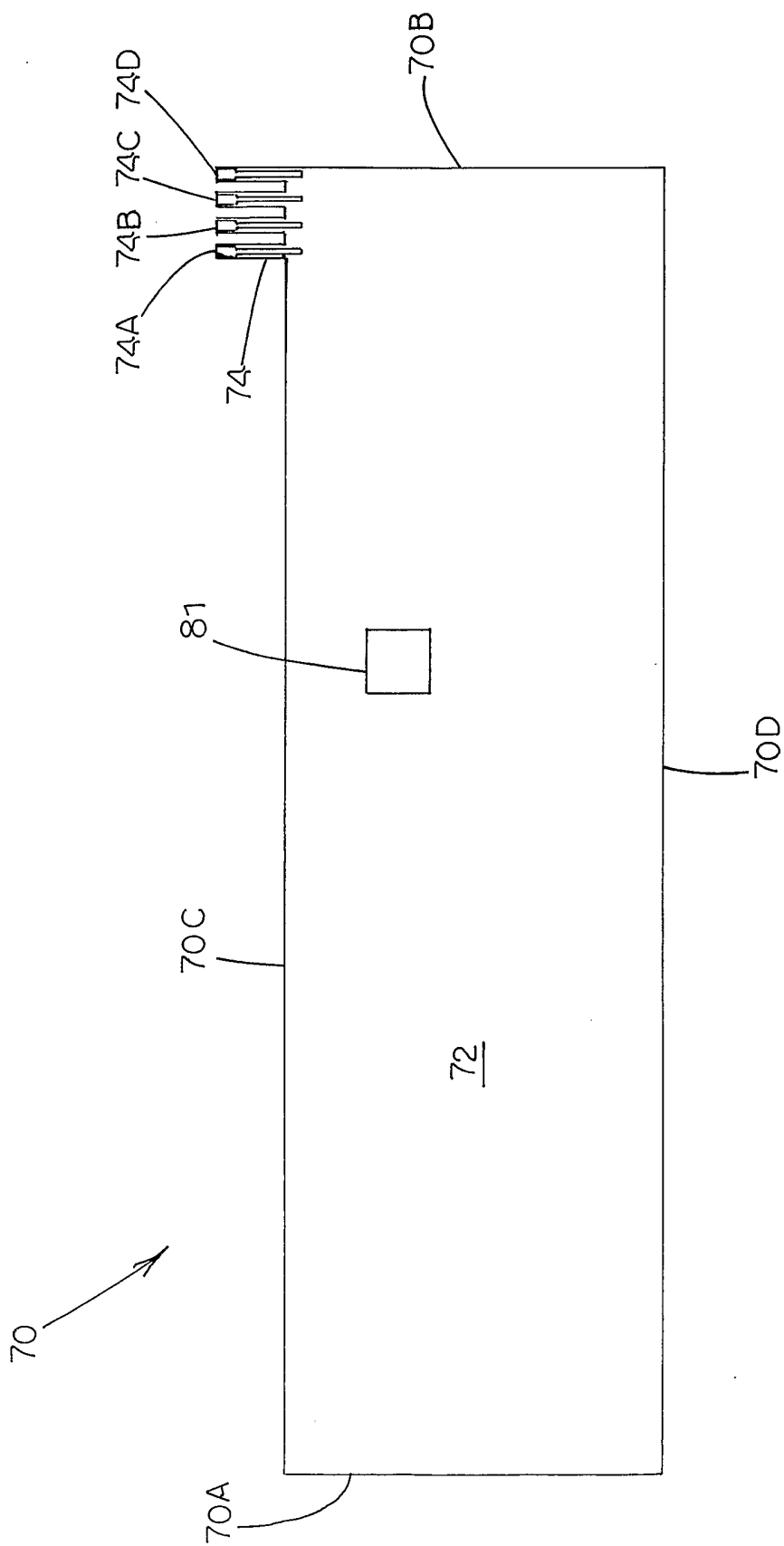

FIG. 3

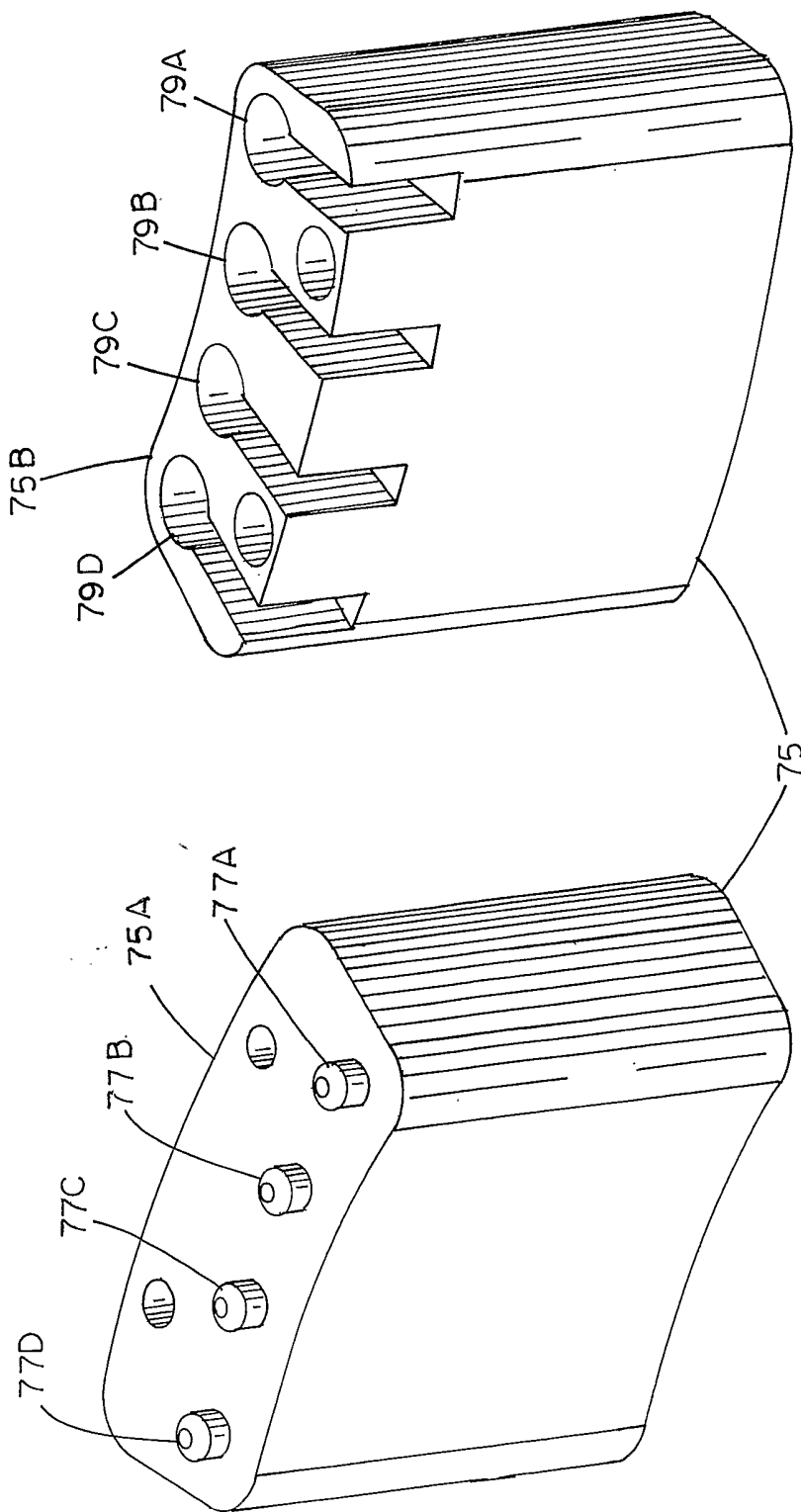

Fig 4B

Fig 4A

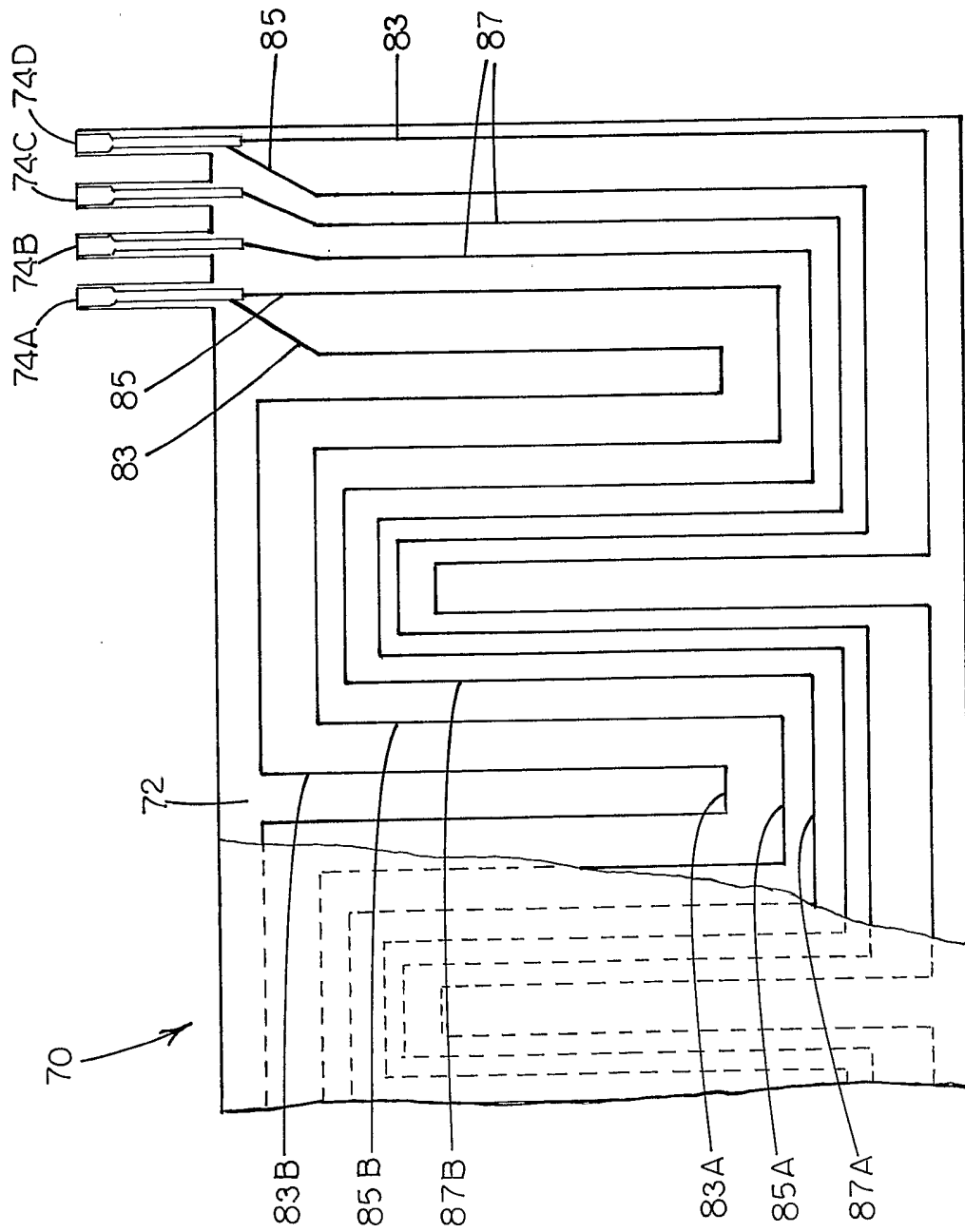

Fig.5

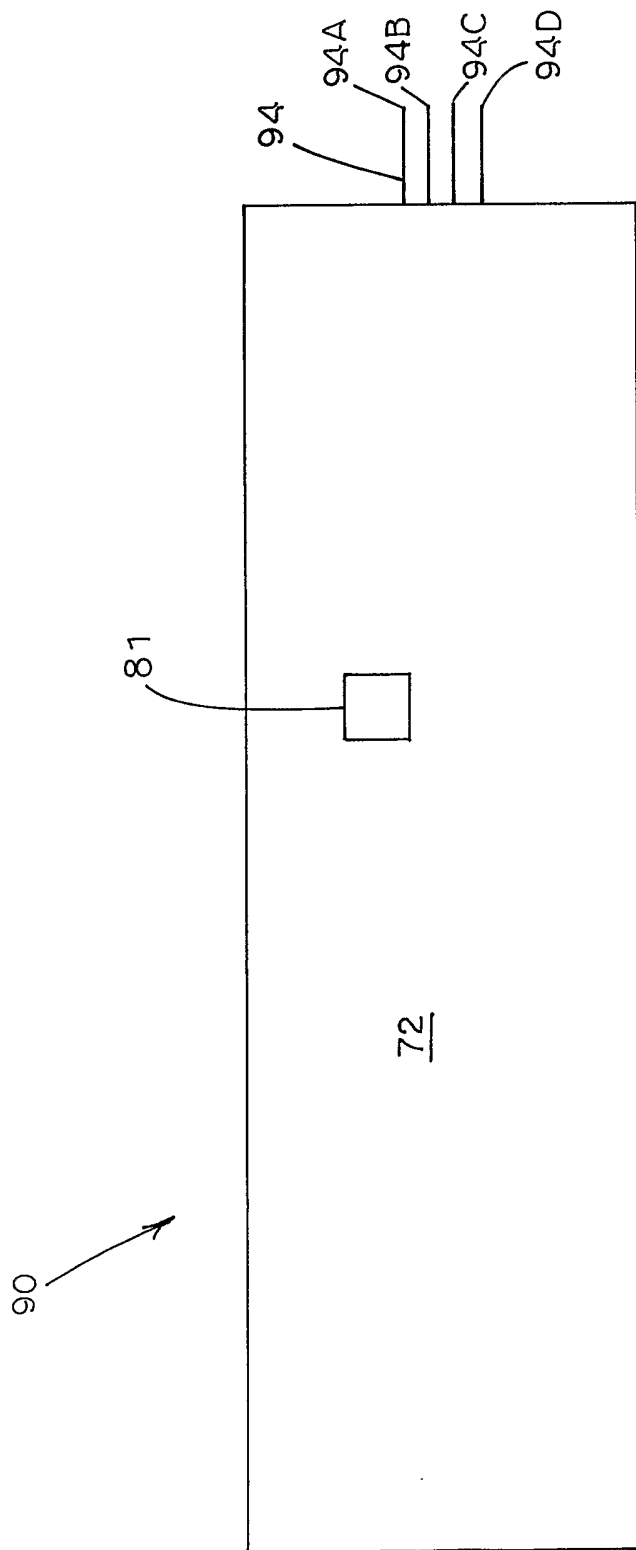

FIG. 6

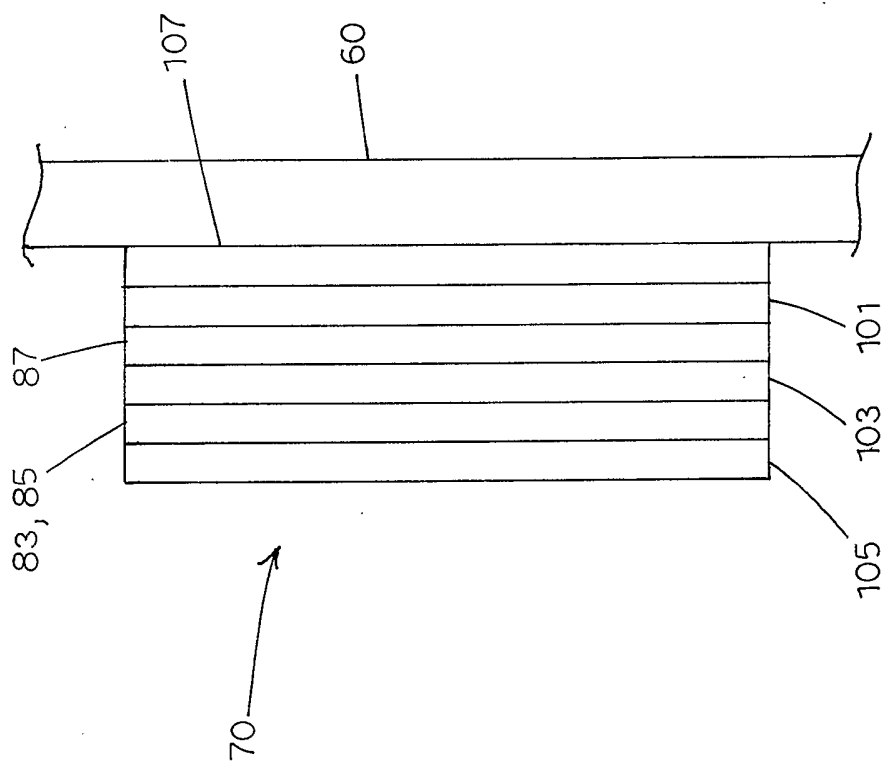
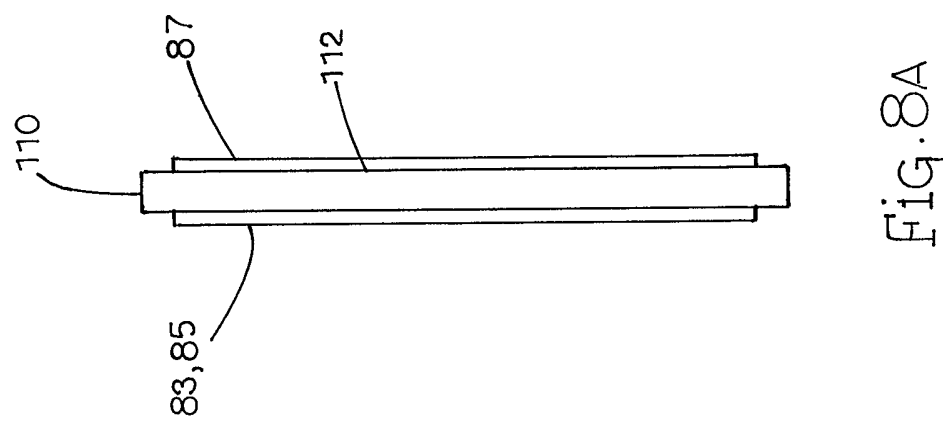
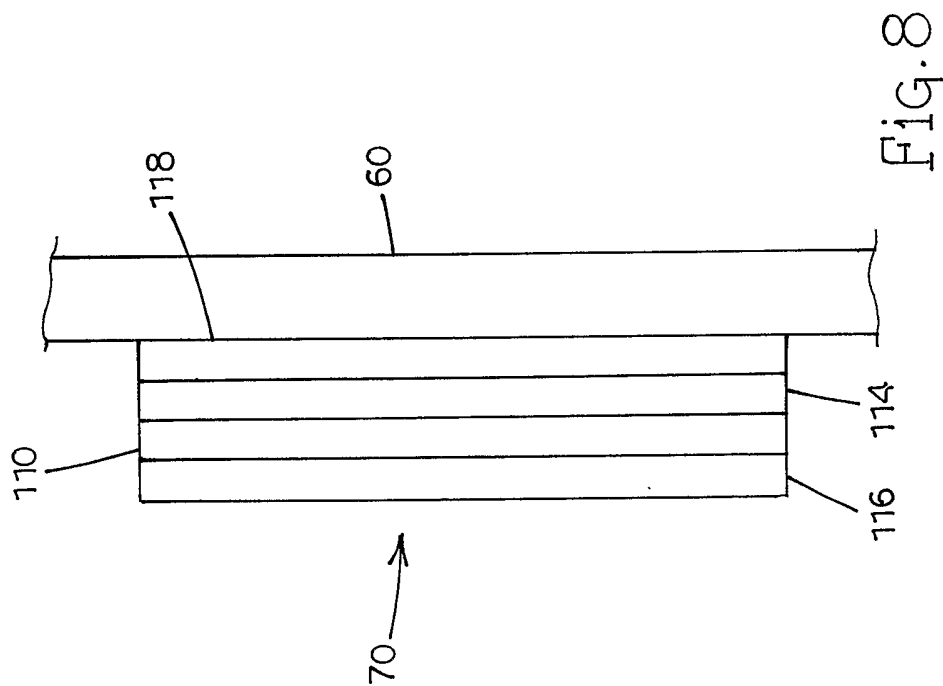

FIG. 7



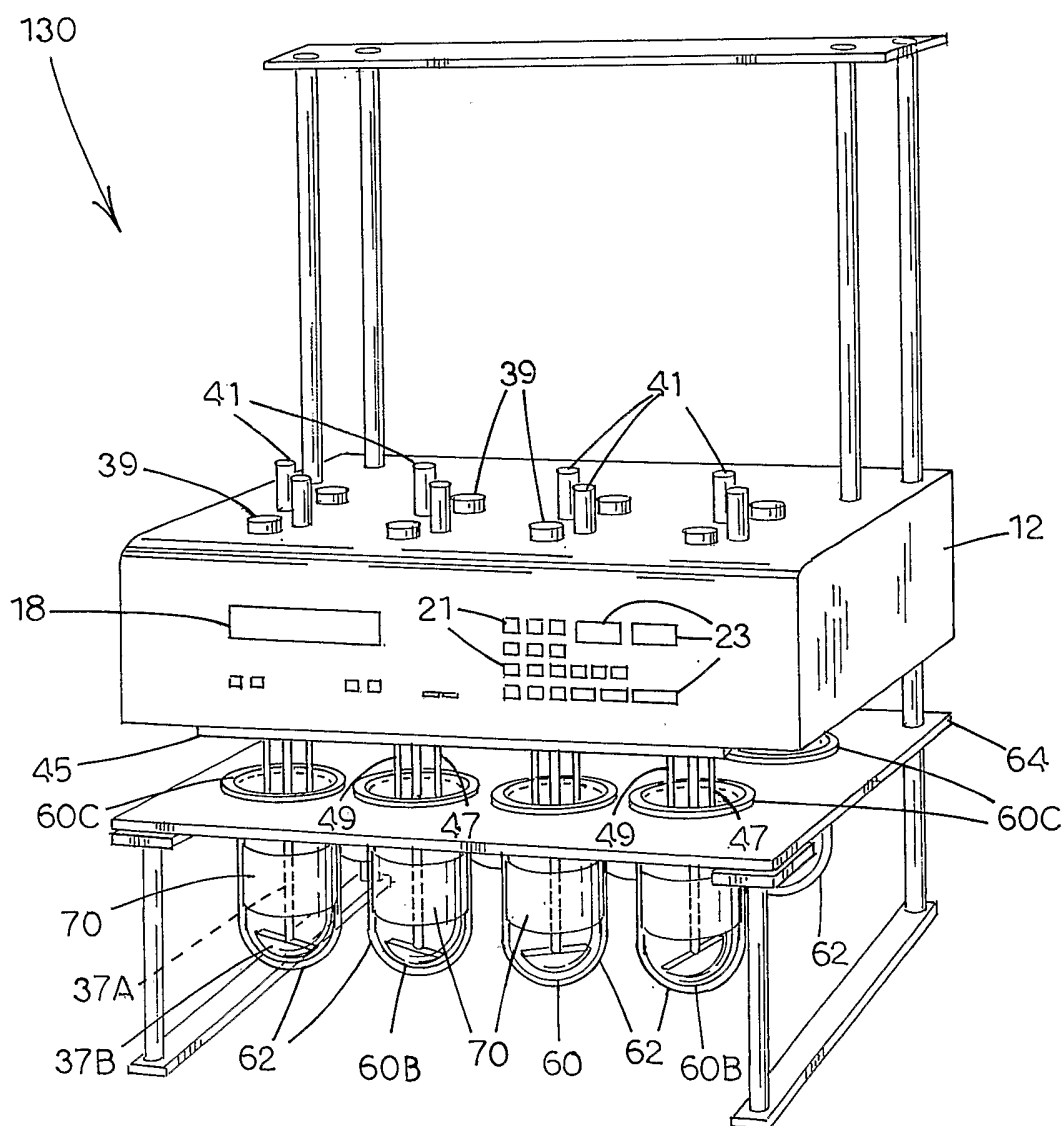

Fig. 9

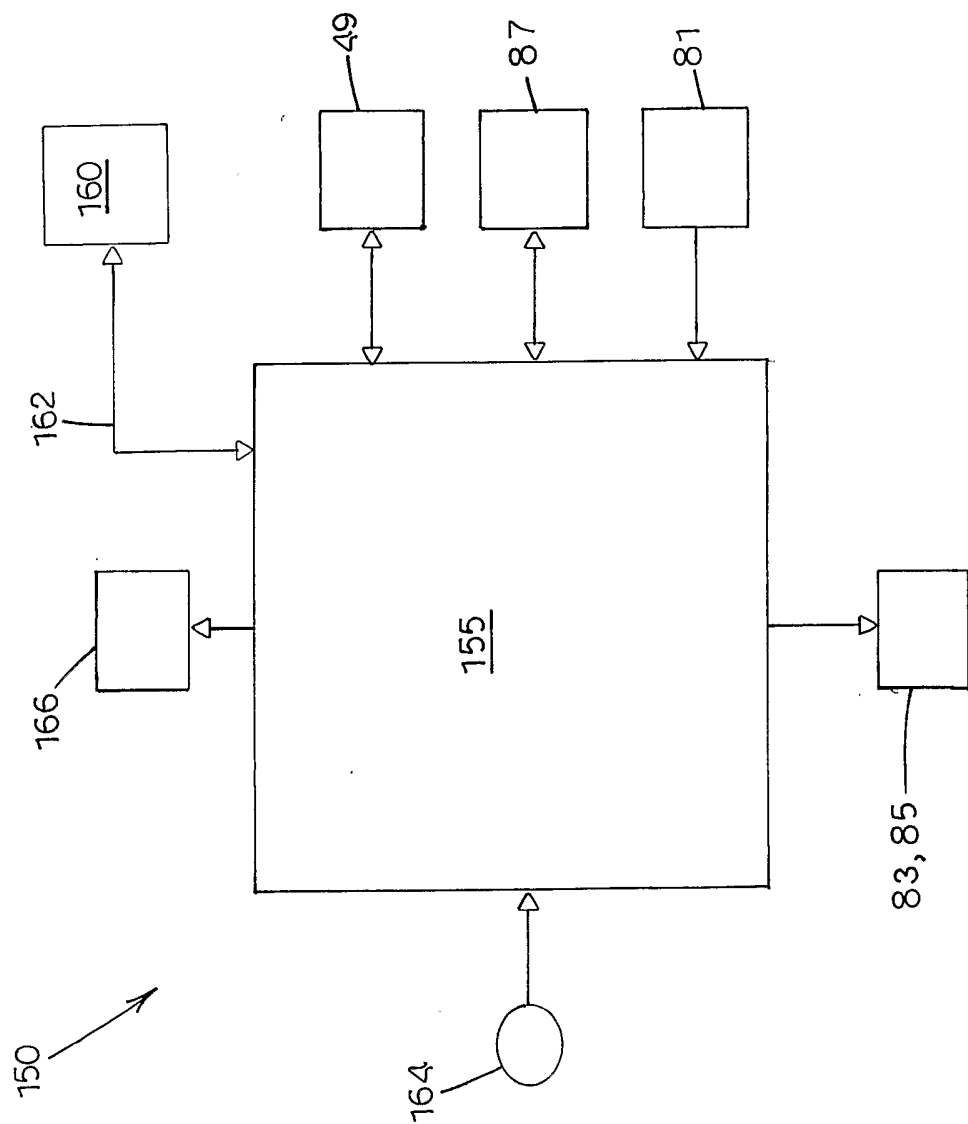

Fig.10

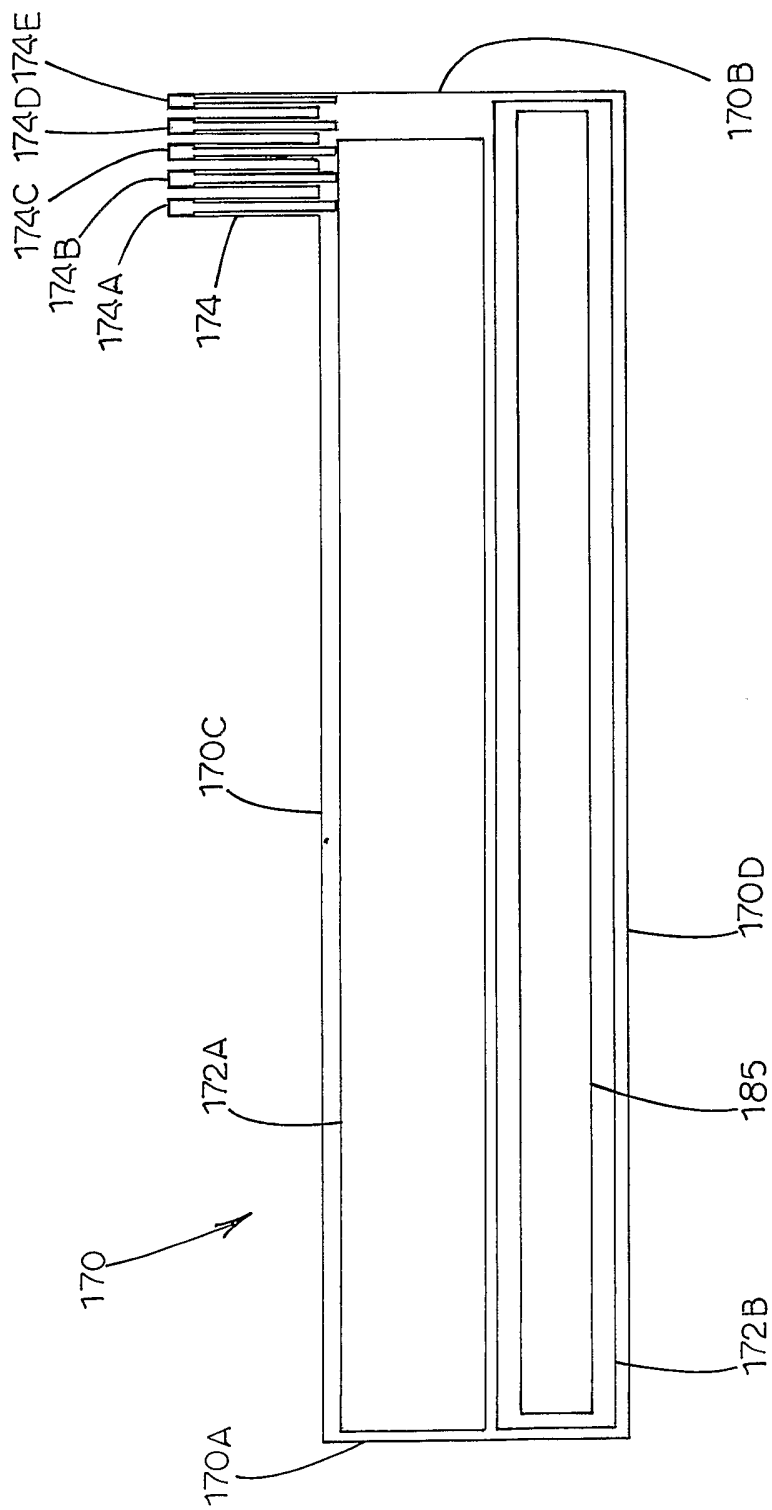

Fig.11

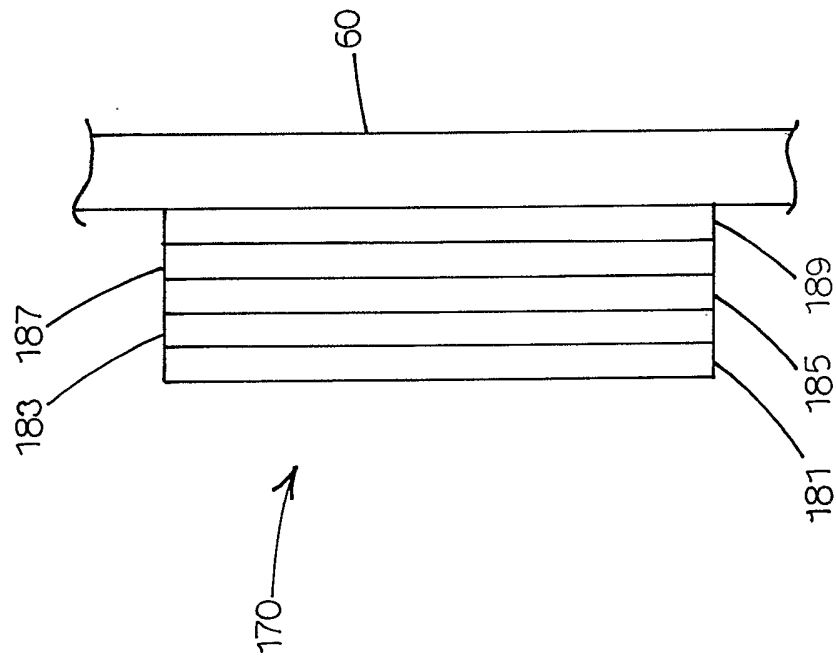

Fig.12