

[54] **SIGNAL SEQUENCING SYSTEM**

[72] Inventors: Andre Wavre, Monroeville; Dean Santis, Pittsburgh, both of Pa.

[73] Assignee: Westinghouse Electric Corporation, Pittsburgh, Pa.

[22] Filed: Feb. 13, 1969

[21] Appl. No.: 798,914

[52] U.S. Cl. 340/168, 176/22

[51] Int. Cl. H04q 42

[58] Field of Search 176/193.3, 22; 235/92 PE, 92 MP; 340/147, 185, 184, 168; 214/18

[56] **References Cited**

FOREIGN PATENTS OR APPLICATIONS

226,843 9/1958 Australia 204/193.3

Primary Examiner—Eugene G. Botz

Attorney—A. T. Stratton, Z. L. Dermer and J. W. Wigert, Jr.

[57] **ABSTRACT**

A system is disclosed for providing sequential control signals to an apparatus including a plurality of M banks of elements, wherein each bank comprises up to N elements and wherein the banks are moved in either a forward or reverse direction by incremental steps and wherein the groups within the banks are each moved incrementally in a cyclical manner. Such an apparatus could be the well known jack mechanism for moving the respective positions of a plurality of control rods operative with a reactor device. A reversible control signal counter is provided which counts the cumulative number of steps taken by all of the M banks. Adjustable decoding means provide selected signals at predetermined counter states. The selected signals are indicative of the incremental steps taken by the first and final group of elements during bank sequencing. Means are provided responsive to the selected signals to provide sequential bank signals. The disclosure includes means for insuring that the last element moved prior to a change in sequencing direction is the first to be moved in the opposite direction when a change of direction is desired. Means are also provided to insure that misalignment of the elements within the bank cannot occur.

13 Claims, 9 Drawing Figures

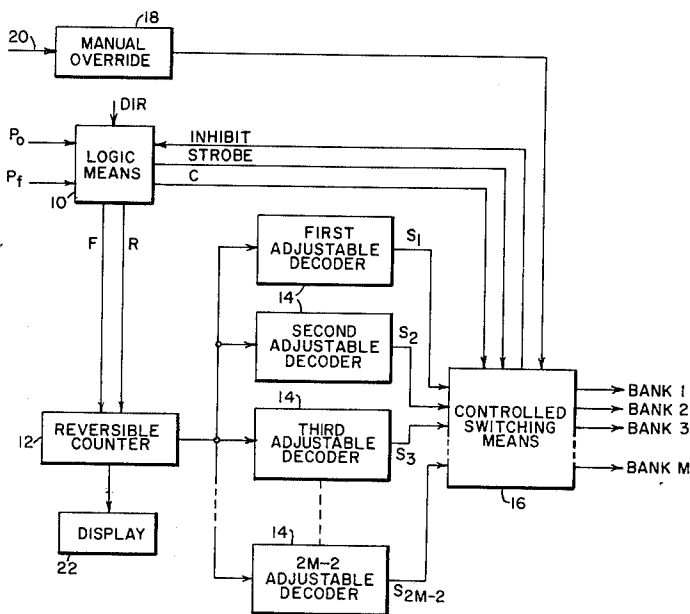

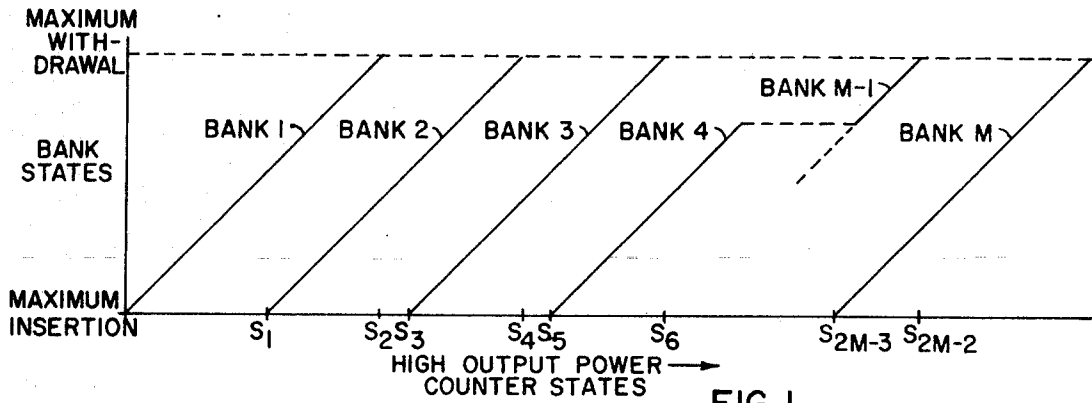

FIG. 1.

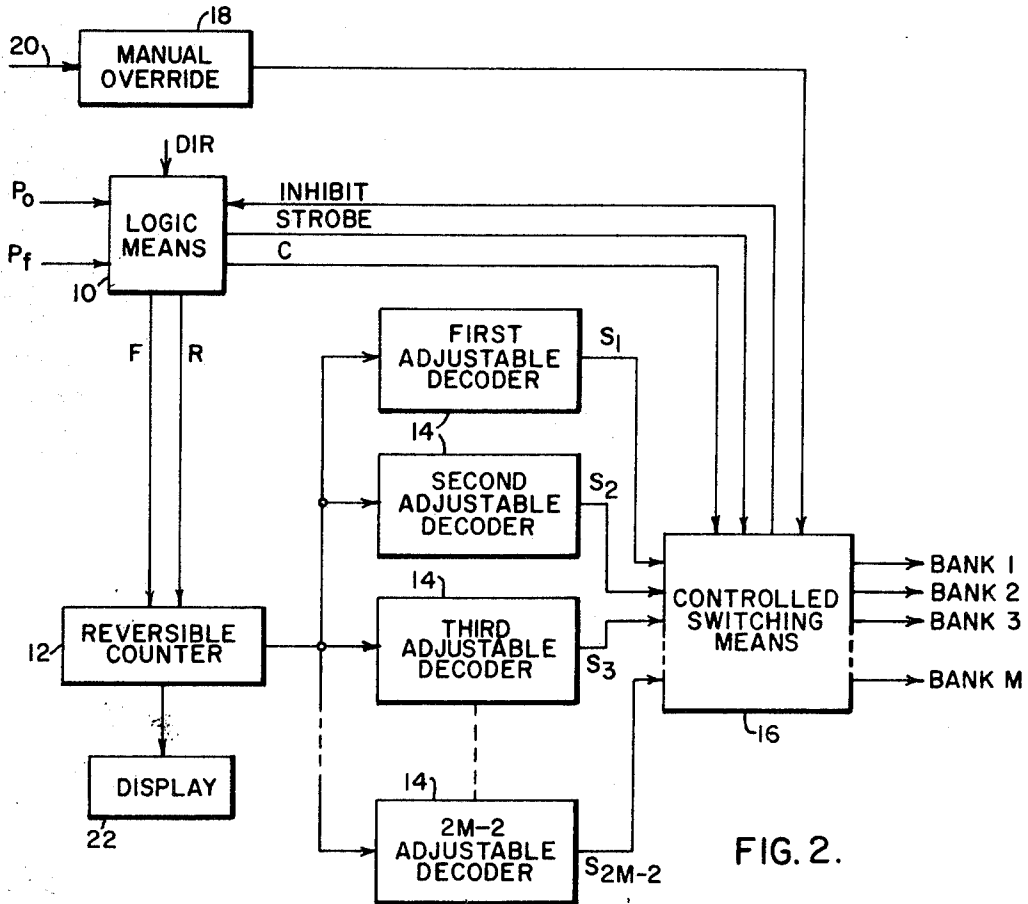

FIG. 2.

WITNESSES:

Leon M. Gorman
James J. Young

INVENTORS
 Andre Wavre and
 Dean Santis.

BY *J. William Wigert Jr.*
 ATTORNEY

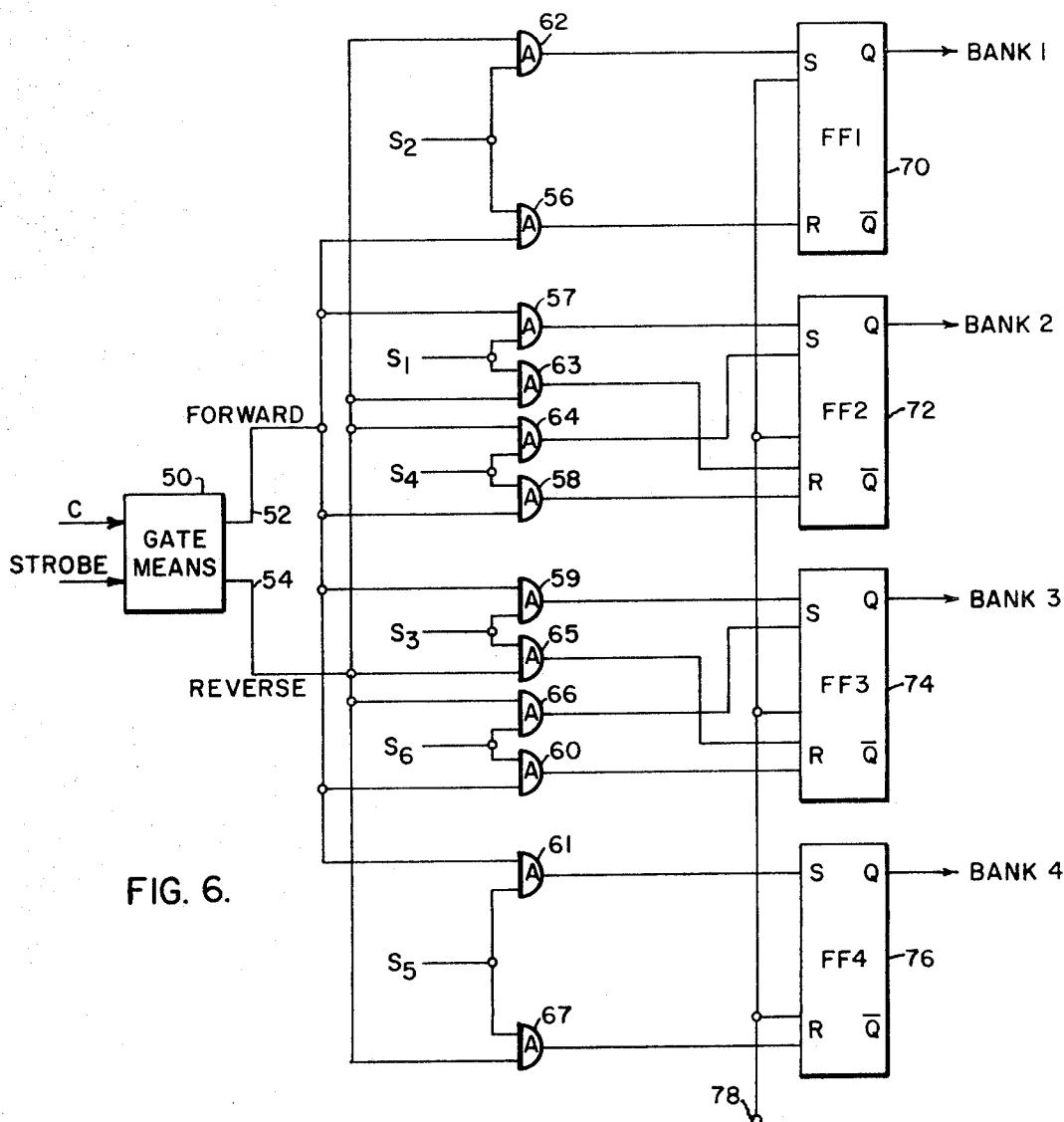
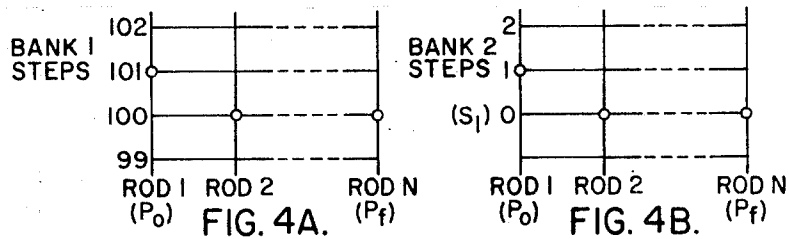
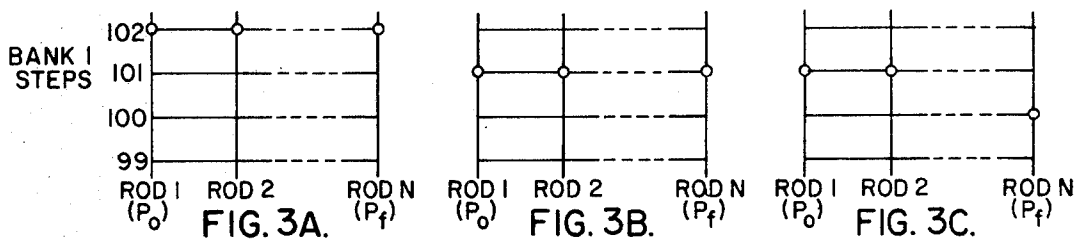

FIG. 6.

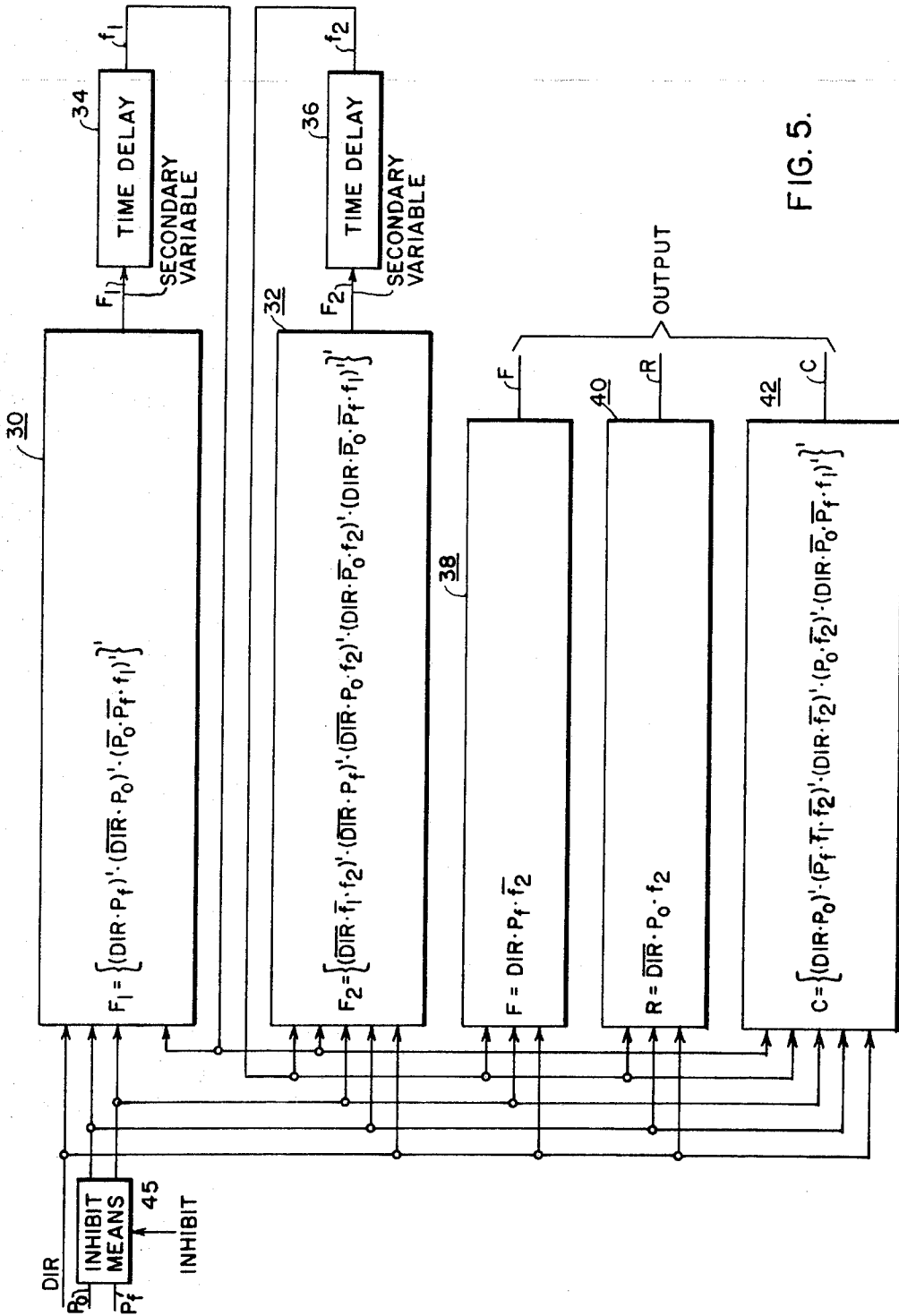

FIG. 5.

SIGNAL SEQUENCING SYSTEM

CROSS-REFERENCES TO RELATED APPLICATIONS

The present invention is related to the invention covered by copending patent application (Westinghouse Case No. 40,534) Ser. No. 798,911, filing data Feb. 13, 1969, entitled "Power Regulation System" by Andre Wavre and Francis Thompson, copending application (Westinghouse Case No. 40,535) Ser. No. 798,912, filing date Feb. 13, 1969, entitled "Power Multiplying System" by Andre Wavre; and copending patent application (Westinghouse Case No. 40,536) Ser. No. 798,913, filing date Feb. 13, 1969, entitled "Pulse Sequencing System," by Andre Wavre; all of which are assigned to the assignee of the present invention and filed concurrently herewith.

BACKGROUND OF THE INVENTION

The present invention relates to a system for providing signals to sequence the position of, in either a forward or reverse direction, a plurality of banks of elements such as reactor control rods, composed of up to N elements per bank.

Sequentially inserting or withdrawing a plurality of elements is necessary in a nuclear reactor rod control system. In controlling the operation of a nuclear reactor, it is well known in this art that banks of control rods are sequentially inserted or withdrawn in accordance with the desired energy output of the nuclear reactor. The output of the reactor is increased if control rods are positionally withdrawn from the reactor and decreased if the control rods are positionally inserted into the reactor.

Typically, control rods are arranged in a plurality of banks comprising a number of groups each of which contains one or more rods. When it is desired to increase the output of the reactor, one bank of rods will be sequenced, that is, a first bank of rods will be incrementally withdrawn from the reactor, others will be withdrawn if more power is required. It is generally desirable to begin to withdraw other banks before the first bank has been withdrawn its maximum distance.

Each rod is moved incrementally by a well known jack mechanism. One such jack mechanism is disclosed in U.S. Pat. No. 3,158,766, by E. Frisch. Further, a brief description of the operation of such a jack mechanism is given in patent application Ser. No. 798,912 (Westinghouse Case No. 40,535).

Since each bank is composed of one or more rods or groups of rods, when a bank is inserted or withdrawn, each of these rods or groups of rods are incrementally moved in the desired direction, one at a time. Thus, if a bank is moved up one increment, the first rod or groups of rods will move first, then the second, then the third, and so forth, until the last rod or groups of rods have been moved that one increment. If the direction of the rods is changed, it is necessary that the last rod or groups of rods which have been moved prior to the change in direction, be the first to be moved in the opposite direction when the change of direction is called for. This is necessary in order to maintain proper alignment of the rods within the reactor and the desired control over the operation of the reactor.

Present nuclear reactors typically utilize two banks of rods and employ an electromechanical control bank sequencing unit. Briefly, present sequencing units consist of two reversible, three-decade electromechanical counters. The first counter counts the steps taken by the first control bank and the second counter counts steps taken by the second control bank. When it is desired to increase the power output of the reactor, the first control bank is sequenced. The second control bank is sequenced after the first control bank has taken N1 incremental steps, and the first control bank is halted after the second control bank has taken N2 steps. To lower the power provided by the nuclear reactor, the first control bank is sequenced in a reverse direction, i.e., so as to insert the rods, when the second bank is N2 steps from the maximum inserted point for the second bank, and the second control bank is halted when the first control bank is N1 steps from the point of

maximum inserted distance for the first control bank. The purpose of the overlaps of the banks is to provide the desired control over the incremental change in radioactivity within the reactor.

The latter bank sequencing systems have several disadvantages. First, because the systems are electromechanical in nature they have all the disadvantages associated with electromechanical systems. For example, they are bulkier, less reliable, and have relatively slow response times. Secondly, the present system requires a three-decade reversible counter per bank. For present nuclear plants which incorporate four or more banks, four such counters would be required. Finally, with present systems it is possible to misalign rods or groups of rods within the two banks under certain conditions where direction is changed when the first and second control banks are N1 or N2 steps away from their maximum inserted positions, respectively. This is a highly undesirable disadvantage, particularly in a plant utilizing four or more banks.

SUMMARY OF THE INVENTION

It is therefore an object of the present invention to provide an improved system for sequentially providing signals for sequencing a plurality of banks comprised of individual or groups of elements per bank.

It is further an object of the present invention to provide an improved sequencing unit including solid state circuitry which is highly reliable and better performing than a sequencing unit incorporating electromechanical elements.

A further object of the present invention is to provide an improved sequencing system which is more adaptable for any number of banks of elements or rods.

A further object of the present invention is to provide an improved sequencing unit which is operable to provide signals to banks of elements comprising from one to N elements or groups of elements per bank.

It is further an object of the present invention to provide an improved sequencing unit which will not misalign the elements or groups of elements within a bank under any operating conditions.

It is further an object of the present invention to provide an improved bank sequencing unit wherein the first and the second banks overlap, the second and third banks overlap, the third and fourth banks may overlap, and wherein the first and third banks never overlap and the second and fourth banks never overlap.

It is further an object of the present invention to provide an improved control system which is more capable of being manually overridden.

According to the present invention a single reversible signal counter is provided which is responsive to the cumulative number of position steps taken by the banks. Cumulative step signals are provided by logic means responsive to first and final pulses associated with the first and final rod moved during each incremental step. Adjustable signal decoders are provided which are responsive to predetermined counter state signals according to the points in which each of the banks is to begin and stop sequencing. The adjustable decoders provide signals at these points, which are then sent to a controlled switching circuit which provides sequential bank signals in accordance with the adjustable decoder signals and also in accordance with a signal provided by the logic means indicating the direction and previous directional history of the control rod movement. This signal is important to prevent misalignment among the rods and is provided at times in accordance with the teachings of the present invention. Means are also provided for manually overriding the system and providing an output display indicating the current counter state.

BRIEF DESCRIPTION OF THE DRAWINGS

FIG. 1 illustrates the relationship between the bank sequencing and power output in a nuclear reactor;

FIG. 2 illustrates a bank sequencing system in accordance with the present invention;

FIGS. 3A, 3B and 3C respectively show different rod positions for one bank of rods or groups of rods illustrating the sequential movement of the rods or groups of rods within each control bank.

FIGS. 4A and 4B illustrate the relationship between rods or groups of rods within two different banks of elements;

FIG. 5 illustrates a functional diagram, expressed in Boolean algebra, the logic means shown in FIG. 2 for preventing misalignment between groups within banks; and

FIG. 6 illustrates a schematic of the controlled switching means.

DESCRIPTION OF THE PREFERRED EMBODIMENT

In FIG. 1 the horizontal axis of the graph therein corresponds to the cumulative total number of steps taken by all of the M banks within the reactor. Thus, if bank one and bank two both take a step movement, the cumulative total is still only one step. The greater the number of steps taken, the greater the power output of the reactor. The vertical direction indicates the number of steps taken by each bank. At the origin, the output of the nuclear reactor is zero or minimum. To increase the output power of the reactor, bank one rods are withdrawn incrementally as shown. When bank one has traveled S_1 number of steps, bank two begins to be withdrawn and the power output of the reactor will increase further. When the cumulative number of steps taken reaches S_2 , bank one sequencing is stopped. At counter state S_3 , bank three begins to be withdrawn, at S_4 bank two is halted, and at S_5 bank four begins. For a system comprising M banks it can be seen that bank M will begin to be withdrawn at counter state S_{2M-3} .

To decrease the output of the reactor, the reverse control rod movement sequence takes place. When the counter reaches state S_{2M-3} the bank M is stopped. Bank four is halted when counter state reaches S_5 , bank two begins to be inserted at S_4 , bank three is halted at S_3 , bank one begins to be inserted at S_2 , and bank two is halted at S_1 .

A system for providing the control rod movement sequencing illustrated in FIG. 1 is shown in FIG. 2. Logic means 10 provides two output signals F and R to reversible counter 12, the F signal causing forward count by reversible counter 12, the direction corresponding to a withdrawal of control rods in a nuclear reactor rod control system, and the R signal causing a reverse count by the counter 12, corresponding to insertion of rods in a rod control system. Logic means 10 determines when a bank steps by receiving two input pulses P_0 and P_F . These pulses are associated with movement of the first and final rods or groups of rods within each bank. It should be noted, however, that since the reversible counter counts only the cumulative number of steps taken by the banks, the P_0 and P_F signals need only be associated with any moving bank, since a step by more than one bank will still result in the addition of one additional count by the reversible counter 12.

In the case of a nuclear rod control system, the P_0 and P_F signals desirably, are the actual go signals for the first and final rods or groups of rods sequenced within each bank. A system for providing these pulses is disclosed in the above-mentioned copending patent application Ser. No. 798,913, to Wavre (Westinghouse Case No. 40,536). The forward and reverse signals F and R are given in response to a sequencing direction signal provided to the logic means 10 as shown. The timing of these pulses however, is determined in a manner which will be set forth in detail subsequently.

Each of a plurality of adjustable decoders 14 is responsive to a particular counter level or state. Each state is selected in accordance with the points at which each of the banks are to begin to be sequenced and halted. The respective decoder output signals S_1 , S_2 , S_3 , and so forth, up to a total number of S_{2M-2} , where M is the number of banks in the system, correspond to the points S_1 through S_{2M-2} shown in FIG. 1. A desirable adjustable decoder for providing the aforesaid function is a thumbwheel switch decoder well known in the digital decoding art, which is manually adjustable and which provides

an output signal in response to the states of a binary coded decimal counter.

Signals S_1 through S_{2M-2} are sent to controlled switching means 16. Also inputted to control switching means 16 is a control signal C from logic means 10 and a strobe signal from logic means 10. The strobe signal and the control signal C act to gate signals S_1 through S_{2M-2} as they are sent through the control switching means. Control signal C relates to the direction in which the banks are being sequenced and plays a very important part in the prevention of rod misalignment. Its function will also be described in more detail subsequently.

Controlled switching means 16 comprises a series of binary flip-flops, which when set and reset by the adjustable decoder signals S_1 through S_{2M-2} when the proper strobe and control signal C are present, provide the various bank sequence signals for a plurality of M banks. Details of the aforesaid will be described subsequently.

A manual override 18 when actuated by a manual input signal 20, provides a signal to controlled switching means 16, permitting manual operation of the bank sequencing signals. At the same time controlled switching means 16 sends an inhibit signal to the logic means 10 to override its automatic functions. A display unit 22 may provide a visual display of the signal count within the reversible counter 12. If the reversible counter 12 is, for example, a three-decade counter, then the display 22 would also be a three-decade display unit.

The output signals forward F and reverse R provided by logic means 10 to the reversible counting means 12, and the control signal C , which is either a binary 1 or a binary 0 are provided according to the following operation rules for logic means 10:

Operation Rule 1 - An F pulse signal is given concurrently with a P_F pulse signal whenever forward sequencing is called for and the last pulse received prior to P_F was a P_0 pulse signal.

The reason for this rule is explained in reference to FIG. 3 which illustrates in FIG. 3A a group of N rod elements all situated at step 102 of bank one, which is also step 102 of counter 12. If the rods in bank one are being inserted into a nuclear reactor, the counting direction of the counter 12 would be reverse. In going from level 102 to 101, first, the N th rod would drop an incremental step, then rod $N-1$, and so on through rod 1. The counter 12 is decreased one state only after rod 1 is stepped. Thus, the counter goes from state 102 to 101, only when all of the rods are in the position shown in FIG. 3B.

If the sequencing were now reversed, i.e., if the rods were ordered to be withdrawn, according to Rule 1, an F pulse would be given to the counter 12 since the last pulse received prior to element pulse P_F (corresponding to rod N) was a P_0 pulse (corresponding to rod 1).

If the direction was reversed after rod N had been inserted one additional increment as shown in FIG. 3C, then an F pulse would not be given when rod N was withdrawn a step according to Rule 1 since the last pulse given before the direction change was not a P_0 pulse. Rather, it would not be until the rod N reached the level in FIG. 3A that the Rule 1 would be satisfied, i.e., that an F signal be given only when the last pulse received prior to P_F was P_0 . Were it not for this rule, it can be seen that if a change of direction from reverse to forward was called for at a time when the rods are in a position shown in FIG. 3C, the counter would change from state 101 to state 102 even though the elements are in fact at state 101. The F pulse is not given in this situation until the next succeeding P_F pulse is given.

Operation Rule 2 - An R pulse signal is given concurrently with a P_0 pulse signal whenever reverse sequencing is called for and the last pulse received prior to P_0 was a P_F pulse signal.

This rule is the corollary to Rule 1. The rule prevents an incorrect count in the counter 12 where reverse direction is called for.

Operation Rule 3 - For a change of direction from forward to reverse, the control signal C is changed from 1 to 0.

a. Immediately - if the last pulse signal received was P_F ;

b. After the next P_0 pulse - if the last pulse signal received by logic means 10 was P_0 .

The reason for the last operation rule is as follows. The controlled switching means 16 must know whether or not the sequencing direction is forward or reverse. If signal S_1 is provided at the counter state 100, controlled switching means 16 will provide a bank two signal if the rods are being withdrawn, i.e., if the sequencing is in the forward direction, but will remove the bank two signal if the rods are being inserted, i.e., if the sequencing is in the reverse direction. Thus, it is imperative that the controlled switching means 16 be provided with information as to the history of the movement direction of the control rod system as well as the now desired movement direction. This is the function of control signal C provided by logic means 10.

If the last pulse received was a P_F when direction is changed from forward to reverse, then according to the above operation rule 3a the signal C will be changed immediately from a binary 1, indicating the forward direction to a binary 0, indicating the reverse direction. Accordingly, if all of the rods are at the same level at the time a change of direction from withdrawal to insertion is called for, then signal C goes from 1 to 0.

If the system is reversed with some of the rods at one level and some at another, operation rule 3a is no longer applicable, since misalignment could occur. This may best be illustrated by reference to FIGS. 4A and 4B. In FIG. 4A the number of movement steps taken by bank one of control rod elements are shown. In FIG. 4B the number of movement steps taken by bank two of control rod elements are shown. Note that bank two begins sequencing when an S_1 signal is provided, i.e., when the state of counter 12 is 100 and when $C=1$. Take the example where the system is sequencing in the forward direction and is reversed at the point shown in FIGS. 4A and 4B with rod 1 in both banks one and two at steps 101 and 1 respectively, since the counter 12 will not step up until the last pulse P_F is provided, that is when the last rod P_n moves to the next state, the counter 12, at the time that the reverse direction is called for, will be at state 100, and a signal S_1 is provided to the controlled switching means 16. If the controlled switching means 16 gets a 0 control signal C at this point, it would immediately stop providing the bank two signal since the switching means 16 stops bank two at a counter state of 100 and $C=0$. Thus, this would result in rod 1 in bank two being out of alignment.

The provisions of Operation rule 3b eliminate the possibility of such a misalignment by delaying the change from 1 to 0 of the control signal C to until after the next P_0 pulse is received, when the last pulse signal received by logic means 10 prior to a change in direction was P_0 . It should be noted that this operation rule also covers the situation where the banks are sequenced in the forward direction, are then halted, and then reversed, as well as all other situations where misalignment could occur, when going from forward to reverse.

Operation Rule 4 - For a change in direction from reverse to forward, control signal C is changed from 0 to 1

a. Immediately - if the last pulse signal received by logic means 10 was P_0 ;

b. After the next P_F pulse signal - if the last pulse signal received by logic means 10 was P_F ;

This last operation rule is the corollary to Rule 3. The rule prevents rod misalignment when the sequencing direction changes from reverse to forward.

Logic means 10 performs the functions prescribed by the aforesaid rules. Given these operation rules, one skilled in the art of logical digital design readily could, by utilizing suitable logic elements, such as AND, OR and NOT (inversion) gates, construct a logic means 10.

FIG. 5 illustrates one suitable configuration for logic means 10, expressed in Boolean algebraic terms, for carrying out the functions required by the aforesaid rules. The logic circuit shown is an asynchronous sequential circuit, since it contains secondary internal signals F_1 and F_2 , where:

1. F_1 is defined in functional block 30 and F_2 is defined in functional block 32,

2. DIR is indicative of a forward signal provided to logic means 10,

3. f_1 is a feedback signal from the output of function block 30 to the inputs of blocks 30, 32 and 42 after a time delay provided by the time delay 34,

4. f_2 is a feedback signal from the output of function block 32 to the inputs of blocks 32, 38, 40 and 42 after a time delay 36,

5. A bar over a symbol or combination of symbols, or an apostrophe after a combination of symbols within brackets or parenthesis indicates negation, i.e., the absence of such a signal, and

6. The remaining symbols have been previously defined.

Input signals P_0 , P_F after going through inhibit means 45, and control signal DIR are provided as shown to function blocks 30, 32 and to function block 42 which provides and defines output signal C. Additionally, signal DIR and P_F are provided to function block 38 which provides and defines the output signal F, and signal DIR and P_0 are provided to function block 40 which provides and defines the output signal R.

Details of a suitable controlled switching means 16 are illustrated in FIG. 6 for a four bank system. Control signal C and the strobe signal are inputted to gate means 50 to provide forward and reverse signals from contacts 52 and 54 respectively. Since C is either a binary 1 or 0 signal, the forward signal will be provided when C is a binary 1 and the reverse signal when C is a binary 0, whenever a strobe pulse is provided.

Forward signal output 52 is connected to inputs of AND gates 56, 57, 58, 59, 60 and 61. Reverse signal output 54 is connected to inputs of AND gates 62, 63, 64, 65, 66 and 67. For a system with four banks there will be six adjustable decoders 14 (FIG. 2) PROVIDING THE SAME NUMBER OF SELECTED SIGNALS S_1-S_6 . Signal S_1 is provided at inputs to AND gates 57 and 63, S_2 to 56 and 62, S_3 to 59 and 65, S_4 to 58 and 64, S_5 to 61 and 67 and S_6 to 60 and 66.

The output from AND gates 62 and 56 are sent to set and reset inputs respectively of a first binary flip-flop 70. The outputs from AND gates 57 and 64 are sent to the set input of a second binary flip-flop 72. The outputs from AND gates 63 and 58 are sent to the reset input of flip-flop 72. The outputs from AND gate 59 and 66 is sent to the set input of a third binary flip-flop 74. The outputs from AND gates 65 and 60 are sent to the set input of flip-flop 74. The output from AND gates 65 and 60 are sent to the set input of flip-flop 74. The output from AND gates 61 and 67 are sent to the set and reset inputs, respectively, of a fourth flip-flop 76.

When set, flip-flop 70 provides a bank one output signal, flip-flop 72 a bank two output signal, flip-flop 74 a bank three input signal, and flip-flop 76 a bank four output signal. A reset signal to any of the flip-flops will cause a bank output signal to be stopped.

To begin the bank signal sequence in the forward direction, a signal is provided at terminal 78. This signal resets flip-flop 72, 74, and 76 and sets flip-flop 70 causing a bank one output signal. The rest of the sequence in either the forward or reverse directions may be summarized in the following table:

FORWARD DIRECTION

Adjustable Decoder Signal	Flip-Flop	Bank Signal
S_1	sets 72	Bank 2—ON
S_2	resets 70	Bank 1—OFF
S_3	sets 74	Bank 3—ON
S_4	resets 72	Bank 2—OFF
S_5	sets 76	Bank 4—ON
S_6	resets 74	Bank 3—OFF

REVERSE DIRECTION

Adjustable Decoder Signal	Flip-Flop	Bank Signal
S _a	sets 74	Bank 3—ON
S _b	resets 76	Bank 4—OFF
S ₄	sets 72	Bank 2—ON
S ₃	resets 74	Bank 3—OFF
S ₂	sets 70	Bank 1—ON
S ₁	resets 72	Bank 2—OFF

While there has been shown and described what are at present considered to be the preferred embodiments of the invention, modifications thereto will readily occur to those skilled in the art. It is not desired therefore that the invention be limited to the specific arrangement shown and described and it is intended to include all such modifications as fall within the true spirit and scope of the invention.

What is claimed is:

1. In a system for incrementally inserting or withdrawing in either a forward or reverse direction a plurality of M banks of elements, comprising N elements per bank, wherein each element in each group is incrementally moved in a cyclical manner, apparatus for providing sequential bank signals corresponding to the banks to be sequenced, comprising:

- signal counter means responsive to cumulative incremental bank changes for counting the same;
- adjustable signal decoding means responsive to predetermined selected states of said signal counter means for providing selected state signals; and
- first means responsive to the selected state signals for providing sequential bank signals.

2. Apparatus as in claim 1, including second means responsive to first and final pulse signals provided in accordance with the incremental movement of the first and final elements in each bank, respectively, during each incremental bank movement for providing cumulative incremental bank change signals wherein the last element moved prior to a change in sequencing direction is the first to be moved after the change in direction.

3. Apparatus as in claim 2, wherein said second means further provides a control signal to said first means to provide the same with information as to the sequencing direction to prevent element misalignment.

4. Apparatus as in claim 3 wherein said control signal is at least either a first or second binary digit.

5. Apparatus as in claim 4 wherein the change of the latter said control signal from a first binary digit to a second binary digit when a sequencing direction change from reverse to forward is called for occurs immediately when the change of direction is called for if the last pulse signal received by said second means is a first pulse signal and occurs after the next final pulse signal, if the last pulse signal received by said second means was a final pulse signal.

6. Apparatus as in claim 4, wherein said control signal changes from a second binary digit to a first binary digit when a sequencing direction from forward to reverse is called for either immediately, when the change in direction is called for if the last pulse signal received by said second means was a final pulse signal or after the next first pulse signal, if the last pulse signal received by said second means was a first pulse signal.

7. Apparatus as in claim 2, wherein said cumulative incremental bank change signals comprise first binary signals for forward counting and second binary signals for reverse counting.

8. Apparatus as in claim 7, for preventing erroneous counter states wherein said first binary signal is provided in response to each final pulse signal when forward sequencing is called for and when the last pulse signal provided prior to the final pulse signal was a first pulse signal.

9. Apparatus as in claim 8, for preventing erroneous counter states wherein said second binary signal is provided in response to each first pulse signal when reverse sequencing is called for and when the last pulse signal provided prior to the first pulse was a last pulse signal.

10. Apparatus as in claim 1 wherein said adjustable signal decoding means provides a predetermined number of selected state signals in accordance with the plurality of M banks of elements.

11. Apparatus as in claim 2, including means for selectively inhibiting said second means and manually operating said first means to provide bank signals.

12. Apparatus as in claim 2, including means for providing an output display of the current state of said reversible counter.

13. In a nuclear reactor rod control system, apparatus for providing signals to either incrementally withdraw or insert a plurality of banks of control rods within a nuclear reactor comprising:

- a. means for providing bank control signals to incrementally move the banks of control rods cyclically in a predetermined order; and
- b. means for preventing misalignment of said control rods within each bank during movement of the same.

* * * * *

50

55

60

65

70

75