

E. M. Deery.
Fluting Mach.

N^o 100,989.

Patented Mar. 22, 1870.

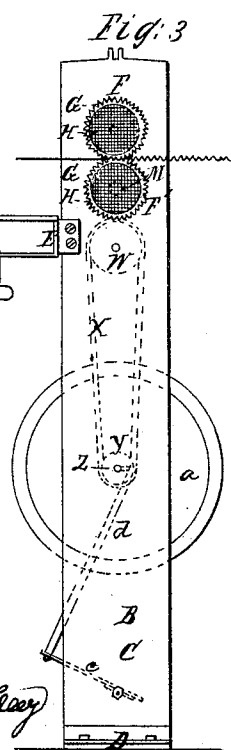
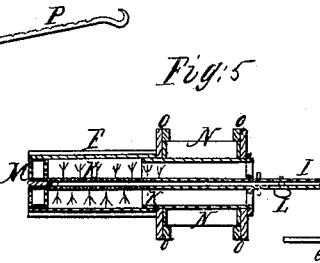
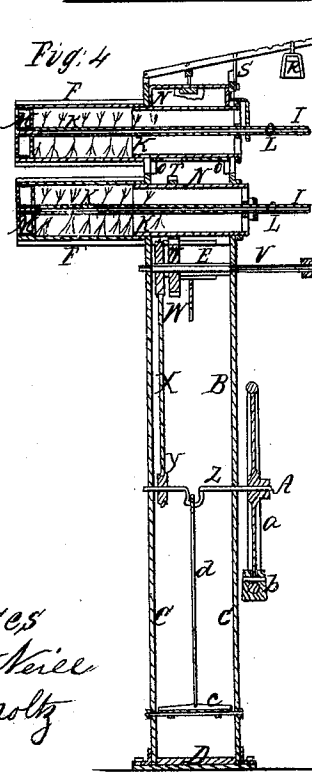
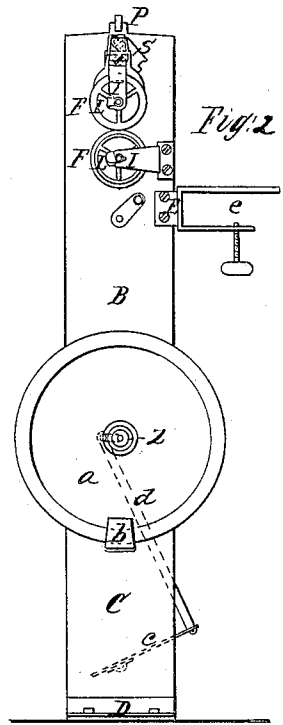
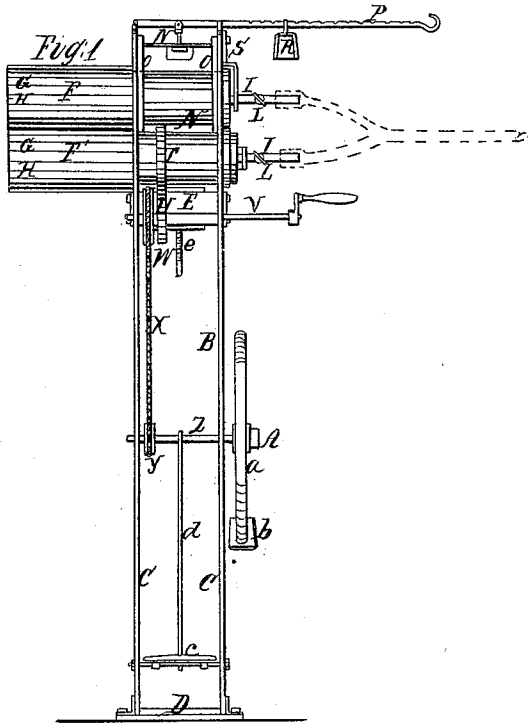

Witnesses
Arthur Keil
Emile Moly

Inventor
Edward Mortimer Deery

United States Patent Office.

EDWARD MORTIMER DEEY, OF NEW YORK, N. Y.

Letters Patent No. 100,989, dated March 22, 1870.

IMPROVEMENT IN FLUTING-MACHINES.

The Schedule referred to in these Letters Patent and making part of the same

I, EDWARD MORTIMER DEEY, of New York, in the county of New York and State of New York, have invented certain Improvements in Fluting-Machines, of which the following is a specification.

My invention relates to that class of machines employed for fluting, crimping, or ruffling the frills and flounces of ladies' dresses, &c; and

It consists of constructing the fluting-rollers as hollow cylinders for reception of perforated gas-pipes, and providing the ends of said rollers with double wire-gauze diaphragms, in such manner that on igniting the gas, the same will be delivered on the interior of the fluting-rollers in the form of fine jets of flame, thereby heating the rollers to the desired degree for fluting or ruffling, while escape of the flame, or too much heat through the ends of the rollers, is prevented by the wire-gauze diaphragms.

And it further consists in arranging the fluting-rollers in a frame-work, and applying to the same a treadle, fly-wheel, starter, pulley, and intermediate gear, in such manner that the machine can be operated by a person's foot, leaving both hands at liberty to feed the material to be fluted between the fluting-rollers, while for light work the machine is also provided with a crank-handle for operating the machine by hand, when desired, and a clamp for attaching the machine to a laundry table, as I will further explain by reference to the accompanying drawings, of which—

Figure 1 represents a front elevation of my invention;

Figure 2, a side elevation;

Figure 3, an elevation of opposite side;

Figure 4, a vertical section; and

Figure 5, a horizontal section through one of the corrugated rollers.

In the said drawings—

B indicates the frame of the machine, which consists of two upright pieces C C, bolted to a foot or base, D, and united at top by a brace, E.

This frame sustains in suitable bearings the hollow corrugated fluting-rollers F F'

These rollers are corrugated on their outer surface, or made with alternate flutes and fillets, G H, of the form desired for fluting articles of wearing apparel, said corrugations also aid in rotating the upper roller F.

The fluting-rollers receive gas-pipes I I, perforated at K K, and provided with stop-cocks L L, for regulating the amount of heat required.

The rollers also receive in their outer ends double-gauze diaphragms M M, for preventing escape of flame or too much heat.

N is the presser, which slides freely in guides O O, near the top of the frame, said presser being operated by the lever P, with a rack, and carrying a weight, R, for regulating the required pressure when the rollers are in action, said lever and slide (which

sustains roller F) also throwing said roller out of action, when desired, and holding same in such position by means of the stay or prop, S, (see fig. 4.)

The lower fluting-roller F' carries a gear, T, which plays into a gear, U, on the hand-crank shaft V, said shaft V being provided with a pulley, W, and a belt, X, which passes over a pulley, Y, on the starting fly-wheel crank-shaft Z.

The starting fly-wheel consists of an ordinary plate-wheel, a, carrying on its rim or periphery a balance-weight, b, which aids in starting the treadle c, connected with the shaft Z by the link d, and

e is the clamp for attaching the machine to a laundry table.

The treadle may be placed in front of the rollers, and instead of the hand-crank and fly-wheel shafts there may be but one shaft for operating the machine (by foot or hand) if preferred.

The operation of my invention is as follows:

I convey gas through a flexible pipe to the perforated gas-pipes I I, regulating the amount of gas required by the stop-cocks L L, and I ignite the gas.

I next elevate the upper fluted roller F by means of the lever N, (see fig. 4,) and introduce the material to be fluted, crimped, or ruffled between the fluting-rollers F F', and I next remove the stay S from the weighted lever P, drop the roller F, and adjust the weight on the lever to obtain the desired pressure between the rollers by the presser N.

I now, by means of the fly-wheel starter, put the machine in motion, and continue the same with my foot on the treadle, carrying power through the belt X, gears U T, and corrugations G H, imparting intermittent rotary movements to the fluting-rollers F F', and thus I crimp, ruffle, or flute the material as desired, while damage to the material by jets of flame or too much heat is prevented by the diaphragms M M.

I am aware that a patent has been granted to T. Robjohn, July 21, 1863, in which a jet of gas is brought to impinge on the extremities of the fluting-roller shafts, for the purpose of heating the rollers, which being entirely different from any mode of heating the fluting-rollers, I do not claim such.

What I claim is—

The perforated gas-pipes I I, hollow corrugated fluting-rollers F F', diaphragms M M, presser P, gears T U, pulleys W Y, fly-wheel starter a, and treadle c, combined, arranged, and operating substantially as and for the purposes described and set forth.

In testimony whereof I hereunto set my signature this 12th day of February, 1870.

EDWARD MORTIMER DEEY.

Witnesses:

ARTHUR NELL,
EMILE MOLTZ.