

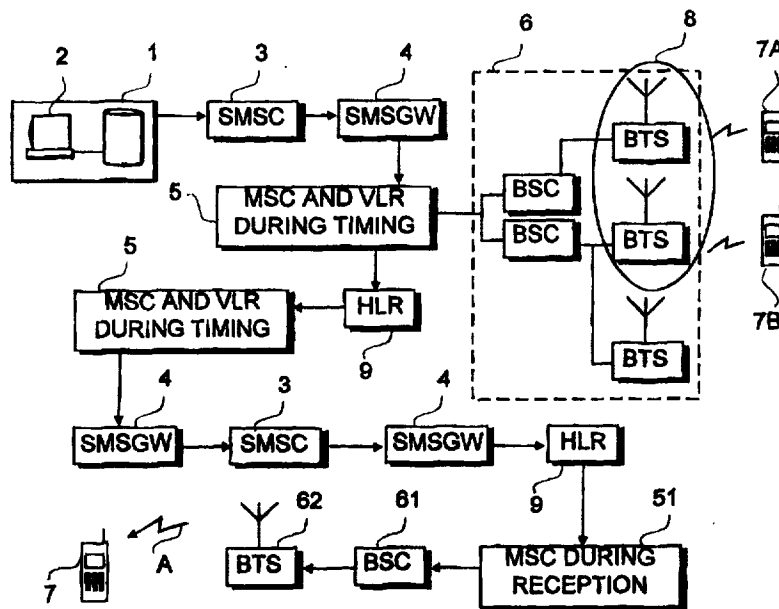

INTERNATIONAL APPLICATION PUBLISHED UNDER THE PATENT COOPERATION TREATY (PCT)

<p>(51) International Patent Classification <sup>6</sup> : <b>H04Q 7/22</b></p>	<p><b>A1</b></p>	<p>(11) International Publication Number: <b>WO 98/09451</b> (43) International Publication Date: 5 March 1998 (05.03.98)</p>
<p>(21) International Application Number: PCT/FI97/00490 (22) International Filing Date: 26 August 1997 (26.08.97) (30) Priority Data: 963375 29 August 1996 (29.08.96) FI (71) Applicant (for all designated States except US): NOKIA MOBILE PHONES LTD. [FI/FI]; Keilalahdentie 4, FIN-02150 Espoo (FI). (72) Inventors; and (75) Inventors/Applicants (for US only): HEINONEN, Pekka [FI/FI]; Hakakuja 2 B 28, FIN-02100 Espoo (FI). OKKONEN, Harri [FI/FI]; Salonkitie 5 as 3, FIN-02940 Espoo (FI). TUOMI, Ilkka [FI/FI]; Arkadiankatu 20 A 19, FIN-00100 Helsinki (FI). (74) Agent: JOHANSSON, Folke; Nokia Mobile Phones Ltd., P.O. Box 100, FIN-00045 Nokia Group (FI).</p>	<p>(81) Designated States: AL, AM, AT, AU, AZ, BA, BB, BG, BR, BY, CA, CH, CN, CU, CZ, DE, DK, EE, ES, FI, GB, GE, GH, HU, IL, IS, JP, KE, KG, KP, KR, KZ, LC, LK, LR, LS, LT, LU, LV, MD, MG, MK, MN, MW, MX, NO, NZ, PL, PT, RO, RU, SD, SE, SG, SI, SK, SL, TJ, TM, TR, TT, UA, UG, US, UZ, VN, YU, ZW, ARIPO patent (GH, KE, LS, MW, SD, SZ, UG, ZW), Eurasian patent (AM, AZ, BY, KG, KZ, MD, RU, TJ, TM), European patent (AT, BE, CH, DE, DK, ES, FI, FR, GB, GR, IE, IT, LU, MC, NL, PT, SE), OAPI patent (BF, BJ, CF, CG, CI, CM, GA, GN, ML, MR, NE, SN, TD, TG).</p> <p><b>Published</b> With international search report. Before the expiration of the time limit for amending the claims and to be republished in the event of the receipt of amendments. In English translation (filed in Finnish).</p>	

(54) Title: AN OPINION POLL UTILIZING A WIRELESS DATA TRANSMISSION CONNECTION



(57) Abstract

The scope of the present invention is a method and a system for sending messages and for the processing of the received answers to the messages sent. In order to that it would be possible to make for example a quick and local opinion poll, a message (A) is fed from a communicator's (1) data processing system (2) over a service center (3) utilizing a wireless telecommunication connection essentially simultaneously to at least two recipients in the telecommunication devices (7) of the recipients, the recipients enter the answer to the message (A) with their telecommunication devices (7) over the service center (3) utilizing a wireless telecommunication connection back to the communicator's (1) data processing system (2) which waits for the answers for a certain, predetermined time, and the information contained in the answers is processed in a predetermined way in the communicator's (1) data processing system (2).

**FOR THE PURPOSES OF INFORMATION ONLY**

Codes used to identify States party to the PCT on the front pages of pamphlets publishing international applications under the PCT.

AL	Albania	ES	Spain	LS	Lesotho	SI	Slovenia
AM	Armenia	FI	Finland	LT	Lithuania	SK	Slovakia
AT	Austria	FR	France	LU	Luxembourg	SN	Senegal
AU	Australia	GA	Gabon	LV	Latvia	SZ	Swaziland
AZ	Azerbaijan	GB	United Kingdom	MC	Monaco	TD	Chad
BA	Bosnia and Herzegovina	GE	Georgia	MD	Republic of Moldova	TG	Togo
BB	Barbados	GH	Ghana	MG	Madagascar	TJ	Tajikistan
BE	Belgium	GN	Guinea	MK	The former Yugoslav Republic of Macedonia	TM	Turkmenistan
BF	Burkina Faso	GR	Greece	ML	Mali	TR	Turkey
BG	Bulgaria	HU	Hungary	MN	Mongolia	TT	Trinidad and Tobago
BJ	Benin	IE	Ireland	MR	Mauritania	UA	Ukraine
BR	Brazil	IL	Israel	MW	Malawi	UG	Uganda
BY	Belarus	IS	Iceland	MX	Mexico	US	United States of America
CA	Canada	IT	Italy	NE	Niger	UZ	Uzbekistan
CF	Central African Republic	JP	Japan	NL	Netherlands	VN	Viet Nam
CG	Congo	KE	Kenya	NO	Norway	YU	Yugoslavia
CH	Switzerland	KG	Kyrgyzstan	NZ	New Zealand	ZW	Zimbabwe
CI	Côte d'Ivoire	KP	Democratic People's Republic of Korea	PL	Poland		
CM	Cameroon	KR	Republic of Korea	PT	Portugal		
CN	China	KZ	Kazakstan	RO	Romania		
CU	Cuba	LC	Saint Lucia	RU	Russian Federation		
CZ	Czech Republic	LI	Liechtenstein	SD	Sudan		
DE	Germany	LK	Sri Lanka	SE	Sweden		
DK	Denmark	LR	Liberia	SG	Singapore		
EE	Estonia						

**AN OPINION POLL UTILIZING A WIRELESS DATA TRANSMISSION CONNECTION**

The present invention relates to a method for transmitting messages and the processing of received answers to the transmitted messages. A further object of the invention is a system for transmitting messages and the processing of received answers to the transmitted messages, which system comprises a communicator's (message sender's) data processing system comprising means for selecting a target group, for transmitting a message and for receiving answers, a service center comprising means for transferring the message and the answer, and a telecommunication device for receiving messages.

The invention relates in particular to making small-size opinion polls, but it is possible to utilize the method according to the invention also in other two-way communication. In the following the invention is though explained in an exemplary way in particular in connection with making opinion polls.

Opinion polls have traditionally been made by mailing a questionnaire to the answering party, by making personal on-site interviews, by making personal interviews by telephone and by requesting in television and/or radio broadcasts the interviewees to call certain telephone numbers, in which case the opinion is expressed by dialing a telephone number corresponding to the opinion or by entering DTMF -signals, i.e. by pushing the telephone keys based upon a voice or a vocal message heard from the called-up telephone number. In publication WO 88 05 239 "Improved polling system" it is explained a system operating in the fixed telephone network, in which system by utilizing programmable units and a voice messages a data system is made to call the interviewees, who answer the questions using their telephone devices according to the instructions of the voice message.

A letter poll can be directed to a certain area, in which case the persons selected to be interviewed are selected based upon their area of residence. A letter poll cannot be directed to persons who were in a certain area at a certain moment.

The problem of a letter poll is also its slowness. The preparing of the material, mailing and the passage of mail itself to both directions all consume their own time. The slowness is increased by the fact that the transfer of the answer information to the enquirer's data processing system for analyzing involves a delay. Another disadvantage is also that a letter poll is delivered to an interviewee's address or to an address into which the interviewee has redirected his/her mail, independent of where the interviewee is at the moment. A further problem of a letter poll from a recipient's point of view is that if he/she does not check his/her mail during the answering period, an outdated enquiry cannot be removed from his/her mail. Answering a letter poll further requires that the interviewee takes his/her answer to a letter box.

Personal on-site interviews can be directed to a certain area. Additionally, they can be directed to persons being in this area during a certain period. The period must however be rather long. Normally there are so many persons in an area that only a small part of them is reached. Interviewees selected based upon their place of residence are only reached when at home, in which case an interviewer may have to make several visits. The problem is, independent of the selecting criterion, that the coverage of a poll is highly dependent on the number of persons present on the site. A further problem is that the interviewees cannot be reached simultaneously. From an interviewee's point of view the disadvantage is that he/she should have time to answer the questions just at the time of an interview. Also slowness is a problem of an on-site interview. The preparing of material, printing, an eventual selecting of the interviewers and the interviewers' moving to the site of interview, the interview itself, delivering the answers to the subscriber of the poll and transferring the answer information into the enquirer's data processing systems consume time. In addition to above, the problem of an on-site personal interview is that an interviewer may unconsciously, or even consciously, influence the answers given by the interviewee with his/her body language and/or by presenting the question using his/her own words.

Telephone interviews can be directed to a certain area. In this case the persons selected to be interviewed are selected based upon their place of residence. In prior known methods enquiries cannot be directed to persons who were in a certain place at a certain moment. Even the telephone interview method utilizing a voice message and several telephone lines simultaneously, which was presented in publication WO 88 05 239, has shortcomings. If there is no answer in a telephone number or it is busy, it must be called again, possibly even a number of times during the interview period. In addition to that the number of telephone lines connected to a "polling center" limits the number of interviewees who can be reached simultaneously. Because in the method the answering is done using the dialing equipment of a telephone, the questions are limited to multiple-choice questions only. From the point of view of an interviewee who has answered the phone, the problem of the method is that he/she should have just at the moment of enquiry time to answer the questions.

An opinion poll, in which answers are requested over a television and/or radio broadcast to call certain telephone numbers or to express their opinions in another way, has the problem of limiting the target group and the geographical focusing of a poll. It is possible to try to limit the target group through selecting the media and the broadcasting time, but it is not possible to select the target group demographically. The problem in geographic focusing is that even the smallest area to which a poll can be focused, is geographically a quite large one (e.g. the coverage of a local radio broadcast).

The problem of all above presented methods is that they are very poorly suited for making a small poll with at most a few questions.

The object of this invention is to solve the above problems and to provide a quick method, which reaches one target group at one time and offers versatile geographic focusing possibilities and normal other selecting criterion and which is well suited for even small opinion polls. This goal is achieved with the method according to the invention, which method is characterized in that a message is

entered from a communicator's data system through a service center utilizing wireless data transmission connection essentially simultaneously to at least two recipients to the recipients' telecommunication devices, the interviewees use their telecommunication devices to feed the answer to the message through the  
5 service center utilizing wireless data transmission back to the communicator's data system, which expects the answers for a certain, predetermined time, and the information contained in each answer is processed in a predetermined way in the communicator's data system.

10 The concept essentially simultaneously means in this context that small differences may occur in the time of transmitting a message, which differences are due to delays connected with data processing and data transfer caused by the executing equipment and/or software for example because of eventually required database searches.

15

A further object of the invention is a system in which the method according to the invention can be utilized. A system according to the invention is characterized in that a communicator's data system comprises means for feeding a message to a service center, and means for receiving each answer to the message from the  
20 service center and means for analyzing the information in an answer in the communicator's data system, the service center comprises means for receiving a message from a communicator's data system and means for transferring the message over a wireless data transfer system essentially simultaneously to the telecommunication devices of at least two recipients and means for receiving the  
25 answers of the recipients and for transferring them further to the communicator's data system, and

the telecommunication device comprises means for receiving a message, a user interface for presenting the information contained in a message to the recipient, and means for transmitting the answer entered by the recipient  
30 using the user interface over the wireless data transfer connection, utilizing the service center, to the communicator's data system.

The concept message means in this context any message containing at least one question, which a recipient is desired to answer. A message can thus be an opinion poll with one or several questions or some other opinion enquiry, an official communication containing a question or an advertisement containing a question.

The concept communicator means in this context a sender of a message who makes the inquiries for himself or as a research assignment.

The concept service center means in this context a center belonging to a telecommunication network, which center is capable of attending to the transmitting of messages to right recipients in a format suitable for the latter and of transferring the answers to the communicator in a correct format. Such a service center can be e.g. the short message service center of a GSM -mobile communication network.

The concept telecommunication device means in this context any device suited for wireless communication, with the help of which a recipient can both receive a message and send an answer to the message. Such a telecommunication device can be for example any radio transmitter, such as e.g. a mobile telephone operating over base stations or eventually over a satellite or e.g. a two-way -pager or e.g. a device of PDA (Personal Digital Assistant) -type.

The concept user interface means in this context those parts of a telecommunication device or a part or sub-unit connected to a telecommunication device, by using which the communication is executed. Such a user interface is e.g. the entity formed by the display and keypad of a mobile telephone.

The invention is based upon the concept that polls can be made quickly thanks to the wireless telecommunication, effectively and using little manpower by focusing a poll according to the present selecting criterion (e.g. area of residence, demographic factors) or based upon the location of a telecommunication device at a given moment (e.g. a superstore). The invention is very well suited for small-form polls including a few questions. The most significant advantages of the solution according to the invention are thus the simultaneous distribution of the message to an unlimited amount of recipients, the reaching of the recipients

based upon their location at the moment of reception, and that the message can be answered when it is best suited for the recipient and the answer can be sent from the recipient's present location, and that it is possible to select persons who have been in a certain area at a given moment as a target group, and that said  
5 area can be limited to be very small by utilizing the cellular structure of the telecommunication system, and that a message can be provided with a time stamp, in which case an outdated message is automatically removed, and that the invention offers the possibility of crediting an interviewee's account with an answering fee.

10

In a preferable embodiment of the invention the GSM -mobile telephone system is used as the wireless telecommunication system. This embodiment according to the invention is very advantageous, because its short messages can be delivered even if a telecommunication device is busy. In addition to it, its short message  
15 service center takes care of delivering a message during the validity of the message, if a recipient's telecommunication device, i.e. a mobile telephone of the GSM -system, has not been in connection with the mobile telephone network at the moment a message was transmitted.

20 The preferable embodiments of the method and system according to the invention are presented in enclosed uninterdependent claims 2 - 5 and 7 - 10.

The invention is described in more detail in the following with reference to enclosed figures, of which

25 Figure 1 presents the transmitting of a message to recipients who were in a certain area at a certain moment,

and

Figure 2 presents the delivering of an answer to a communicator.

30 Figure 1 presents a block diagram connected with the transmitting of a message in a first preferable embodiment of the system according to the invention, in which embodiment it is as an example assumed the wireless telecommunication system



to be the GSM (Global System for Mobile Communications) -system, the service center to be the short message service center SMSC (Short Message Service Center) of the GSM -system, the telecommunication device to be a mobile station MS (Mobile Subscriber) of the GSM -system and the target group selected to be the persons staying in a certain area at the so called timing moment. In connection with the short message service center it has been used the term SMSGW (Short Message Service Gateway), which is the common term for SMS-GMSC (Gateway Mobile Switching Center for Short Message Services) and IWMSC (Interworking Gateway Mobile Switching Center for Short Message Services). The invention is explained in the following as an example assuming that the length of a message to be transmitted is between 94 and 160 characters, in which case it can, according to the present GSM -specifications, be transmitted as a normal short message SM (Short Message) of the mobile communication system, but it cannot be transmitted using the general short message broadcasting service because of the length of the message. The GSM -system and its short message service have been explained in more detail for example in publication "The GSM -system for Mobile Communications", M. Mouly, M. B. Pautet, Plaseau, France, 1992 ISBN:2-9507190-0-7, and thus it is not described in more detail in this context.

When communicator 1 has prepared message A, selected using his data system target area 8 and a timing, i.e. the moment when persons in area 8 with their mobile telephones are of interest, and possibly the moment for transmitting the message, if it deviates from the timing, the last time of validity for the message, the last reception time of the answers and possibly the bonus to be granted, the data system of the communicator sends, based upon the command of the communicator, the above information, as a common term for which it is used in the following the term assignment, to short message service center 3. The sending can take place over any network, for example such as the digital multiservice network ISDN (Integrated services digital network), the public, fixed telephone network PSTN (Public Switched Telephone Network) or PLMN (Public Land Mobile Network). Short message service center 3 decodes the received

message into parts and enquires using short message service gateway 4, utilizing mobile switching center MSC (Mobile Switching Center ) and visitor register VLR (Visitor Location Register) 5 and base area subsystem BSS (Base Station Subsystem) 6, from home register HLR (Home Location Register) 9 the required  
5 subscriber data of mobile stations 7A and 7B in target area 8. The subscriber data of each mobile station 7A and 7B in target area 8 is transferred from the own home register 9 of each one, using the assistance of the mobile switching center of the timing moment and visitor register 5 and short message service gateway 4, to short message service center 3, which at the desired moment of enquiry, which  
10 in the following is called reception moment, transmits message A, which is a short message, which it has extracted from the assignment, to mobile telephone 7 asking for the routing instructions to mobile telephone 7 from home register 9 of the mobile telephone using reception moment mobile switching center 51, base station controller BSC (Base Station Controller) 61 and base station BTS (Base  
15 Transceiver Station) 62. If mobile telephone 7 is switched off or in a shade area, short message service center 3 buffers message A to mobile telephone 7, and transmits message A when mobile telephone 7 again is in connection with the network, if the message still is valid. Target area 8 can consist of one cell, a combination of several cells, a location area or location areas. It is also possible  
20 to define the cell of a movable base station as a target area. Depending on the movements of the mobile telephone the mobile switching center, the visitor register and/or the location cell of the mobile telephone may remain the same or change between the timing moment and the reception moment. In any case the system takes care of the message being delivered to the recipient based upon the  
25 actual location of the recipient.

Figure 2 presents a block diagram connected with answering to a message in the first preferable embodiment of the system according to the invention, which has been explained earlier. In Figure 2 a recipient has received message A and read  
30 it in display 10 of his/her mobile station 7. At a time suitable for him/her he/she answers the question/questions using display 10 and keypad 11 and transmits his/her answer A' as a short message over base station 62' corresponding his/her

present location, i.e. the location at the answering moment, base station controller 61', and mobile switching center 51', assisted by short message service gateway 4, to short message service center 3. Short message service center 3 checks whether the answering time of communicator 1 still is valid and if it is, it sends  
5 answer A' to the communicator's data system 2 for further processing. If the answering time has expired, short message service center 3 throws the answer to a "dustbin". Short message service center 3 credits the interviewee's account 12 according to the instructions of communicator 1. The instructions are received by short message service center 3 either together with the assignment from a data  
10 processing system or afterwards from the communicator, when the communicator's data system has analyzed answer A' and verified it to be worth a reward. Data system 2 of communicator 1 processes the answers by analyzing them in a way desired by the communicator. The analyzing may include creating statistics and/or other prior known methods of analyzing opinion polls.

15

It is self evident for a person skilled in the art how the communication in Figure 1 takes place in the GSM -system using the general distribution of a short message service center, and how it takes place when the selecting of a target group is made based upon something else than the location at a given time. It is also self  
20 evident for a person skilled in the art how the communication explained above in Figures 1 and 2 is arranged using other wireless data transfer systems and/or service centers. It is further self evident for a person skilled in the art that the invention in no way limits the length of a message.

25 I has to be understood that the above explanation and the figures connected with it have only been meant to illustrate the present invention. To a person skilled in the art the different variations and modifications of the invention will be evident without deviating from the scope and spirit of the invention presented in enclosed claims.

30

**Claims**

1. A method for sending messages and for the processing of the received answers to the messages sent, **characterized** in that  
5 a message (A) is entered from the data processing system (2) of a communicator (1) over a service center (3) utilizing a wireless data transmission connection essentially simultaneously to at least two recipients to the recipients' telecommunication devices (7),  
the recipients enter an answer (A') to the message (A) using  
10 their telecommunication devices (7) over the service center (3) utilizing the wireless data transmission connection back to the communicator's (1) data processing system (2), which waits for the answers (A') for a certain, predetermined time, and  
the information contained in each answer (A') is processed in a  
15 predetermined way in the communicator's (1) data processing system (2).
2. A method according to claim 1, **characterized** in that the wireless data transfer connection utilizes a mobile communication system.
- 20 3. A method according to claim 2, **characterized** in that the service center (3) is a short message service center of a mobile communication system.
4. A method according to claim 1, 2 or 3, **characterized** in that the recipients (7A, 7B) are selected based upon their location (8) at a given time, which  
25 location (8) is determined utilizing the cellular structure of the system used in the wireless data transmission connection with the accuracy of at least one cell.

5. A method according to claim 1, in which the communicator (1) sends messages connected with an opinion poll, **characterized** in that the information contained in said answers (A') is statistically analyzed in the communicator's (1) data processing system (2).

5

6. A system for transmitting messages (A') and for the processing of the answers arrived to the questions, which system comprises  
a communicator's (1) data processing system (2), comprising means for selecting a target group, for transmitting a message (A) and for receiving answers (A'),

10

a service center (3) comprising means for transferring the message (A) and the answer (A'), and

a telecommunication device (7) for receiving messages (A),  
**characterized** in that

15

the communicator's (1) data processing system (2), comprises means for feeding the message (A) to the service center (3), and means for receiving each answer (A') to the message (A) from the service center (3) and means for analyzing the information contained in the answers (A') in the communicator's (1) data processing system (2),

20

the service center (3) comprises means for receiving the message (A) from the communicator's (1) data processing system (2) and means for transferring the message (A) over a wireless

telecommunication system essentially simultaneously to the

telecommunication devices (7) of at least two recipients and means for receiving the recipients' answers (A') and for transferring them further to the communicator's (1) data processing system (2), and

25

the telecommunication device (7) comprises means for receiving the message (A), a user interface for presenting the information contained in the message (A) to the recipient, and means for transmitting the answer (A') entered by the recipient using the user interface, utilizing the service center (3), over the wireless data transmission connection to the communicator's (1) data processing system (2).

30

7. A method according to claim 6, **characterized** in that the recipient's telecommunication device (7) is a mobile telephone or a two-way pager, and that the service center (3) is a part of a mobile communication system.
8. A system according to claim 7, **characterized** in that said service center (3) is the short message service center of a mobile communication system.
9. A system according to claim 6, 7 or 8, **characterized** in that the service center (3) and the telecommunication device (7) comprise means for transferring the message (A) in a digital format between the communicator's (1) data processing system (2) and the recipient's telecommunication device (7) .
10. A system according to claim 6, 7, 8 or 9, **characterized** in that the service center (3) comprises means for crediting an interviewee's account (12) with a sum determined by the communicator as a response to receiving the answer (A') or as a response to a message received from the data processing system (2) of the communicator (1).

1/1

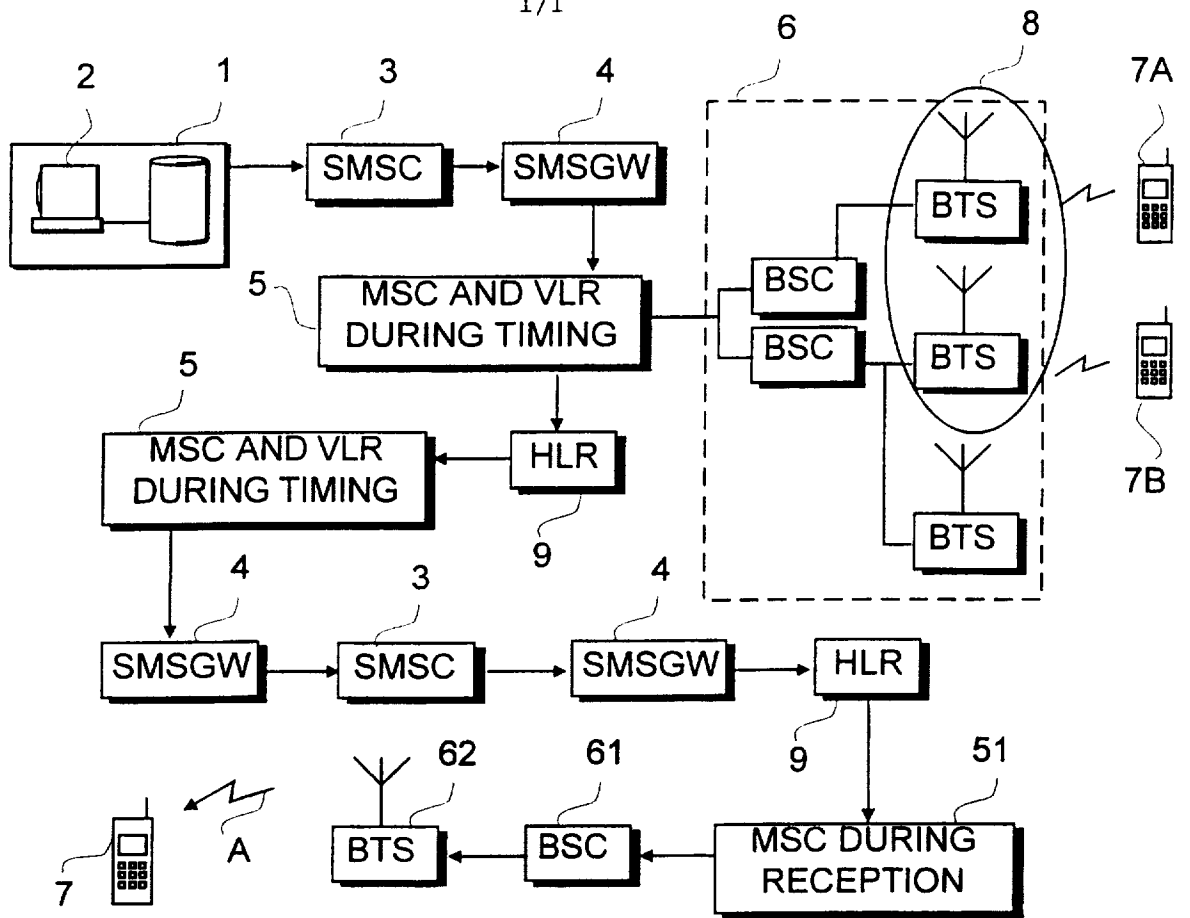

FIG. 1

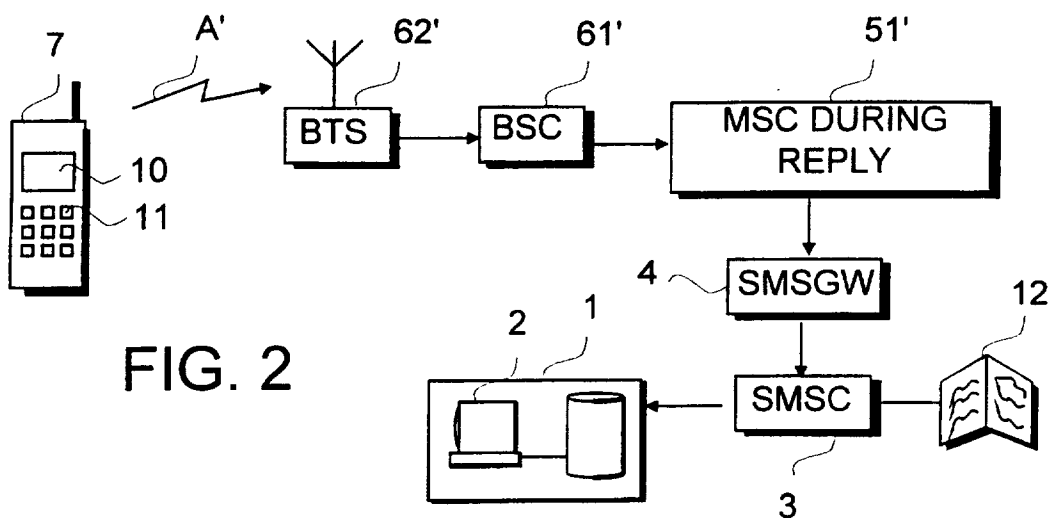

FIG. 2

## INTERNATIONAL SEARCH REPORT

International application No.

PCT/FI 97/00490

## A. CLASSIFICATION OF SUBJECT MATTER

IPC6: H04Q 7/22

According to International Patent Classification (IPC) or to both national classification and IPC

## B. FIELDS SEARCHED

Minimum documentation searched (classification system followed by classification symbols)

IPC6: H04Q

Documentation searched other than minimum documentation to the extent that such documents are included in the fields searched

SE,DK,FI,NO classes as above

Electronic data base consulted during the international search (name of data base and, where practicable, search terms used)

## C. DOCUMENTS CONSIDERED TO BE RELEVANT

Category*	Citation of document, with indication, where appropriate, of the relevant passages	Relevant to claim No.
X	WO 8805239 A1 (M.A. KEMPNER INC.), 14 July 1988 (14.07.88), page 12, line 4 - line 32; page 53, line 24 - line 32	1,2,5-7,10
A	--	3,4,8,9
X	WO 8909530 A1 (CREATIVE COMMUNICATIONS ASSOCIATES INC.), 5 October 1989 (05.10.89), page 2, line 1 - page 3, line 22; page 11, line 5 - line 14; page 15, line 17 - line 27, abstract	1,4,5,6,9
Y	--	2,3,7,8,10

 Further documents are listed in the continuation of Box C. See patent family annex.

\* Special categories of cited documents:

"A" document defining the general state of the art which is not considered to be of particular relevance

"E" earlier document but published on or after the international filing date

"L" document which may throw doubts on priority claim(s) or which is cited to establish the publication date of another citation or other special reason (as specified)

"O" document referring to an oral disclosure, use, exhibition or other means

"P" document published prior to the international filing date but later than the priority date claimed

"T" later document published after the international filing date or priority date and not in conflict with the application but cited to understand the principle or theory underlying the invention

"X" document of particular relevance: the claimed invention cannot be considered novel or cannot be considered to involve an inventive step when the document is taken alone

"Y" document of particular relevance: the claimed invention cannot be considered to involve an inventive step when the document is combined with one or more other such documents, such combination being obvious to a person skilled in the art

"&" document member of the same patent family

Date of the actual completion of the international search

4 February 1998

Date of mailing of the international search report

09 -02- 1998

Name and mailing address of the ISA/  
Swedish Patent Office  
Box 5055, S-102 42 STOCKHOLM  
Facsimile No. +46 8 666 02 86

Authorized officer

Göran Petersson  
Telephone No. +46 8 782 25 00



## INTERNATIONAL SEARCH REPORT

International application No.

PCT/FI 97/00490

## C (Continuation). DOCUMENTS CONSIDERED TO BE RELEVANT

Category*	Citation of document, with indication, where appropriate, of the relevant passages	Relevant to claim No.
X	US 5036389 A (FERNANDO MORALES), 30 July 1991 (30.07.91), column 3, line 9 - line 28; column 4, line 17 - line 37	1,4,5,6,9
Y	--	2,3,7,8,10
X	US 5311507 A (BEDROS A. BEDROSSIAN), 10 May 1994 (10.05.94), abstract	1-3,5-9
A	--	4,10
X	US 5226177 A (RAND B. NICKERSON), 6 July 1993 (06.07.93), column 2, line 55 - line 68; column 4, line 25 - column 5, line 5	1,5,6,9
A	-----	2-4,7,8,10

**INTERNATIONAL SEARCH REPORT**  
Information on patent family members

07/01/98

International application No.  
PCT/FI 97/00490

Patent document cited in search report	Publication date	Patent family member(s)	Publication date
WO 8805239 A1	14/07/88	AU 1107588 A US 4922520 A ZA 8709731 A	27/07/88 01/05/90 24/06/88
WO 8909530 A1	05/10/89	CA 1336840 A EP 0359757 A	29/08/95 28/03/90
US 5036389 A	30/07/91	US 5663757 A	02/09/97
US 5311507 A	10/05/94	NONE	
US 5226177 A	06/07/93	CA 2033558 A,C	28/09/91