

AUSTRALIA

Patents Act

CONVENTION  
60 4971

APPLICATION FOR A STANDARD PATENT

*X*/We A-Dec, Inc

of 2601 Crestview Drive,  
Newberg,  
Oregon,  
UNITED STATES OF AMERICA.

hereby apply for the grant of a standard patent for an invention  
entitled:

**DENTAL INSTRUMENT DELIVERY SYSTEM**

which is described in the accompanying complete specification.

Details of basic application

Number of basic application: 101,796 , 245,675

Convention country in which  
basic application was filed: UNITED STATES OF AMERICA , UNITED STATES OF AMERICA

Date of basic application : 28 September 1987 , 20 September, 1988

Address for Service:

**PHILLIPS ORMONDE & FITZPATRICK**  
Patent and Trade Mark Attorneys  
367 Collins Street  
Melbourne 3000 AUSTRALIA

Dated: 23 September 1988

PHILLIPS ORMONDE & FITZPATRICK  
Attorneys for:  
A-Dec, Inc

By:  
MOO3177

*David B. Fitzpatrick*

Our Ref : 108035  
POF Code: 27179/91368

APPLICATION ACCEPTED AND AMENDMENTS  
ALLOWED ..... 27 - 9 - 90 .....

6012q/1

AUSTRALIA

Patents Act

DECLARATION FOR A PATENT APPLICATION

INSTRUCTIONS

- (a) Insert "Convention" if applicable
- (b) Insert FULL name(s) of applicant(s)
- (c) Insert "of addition" if applicable
- (d) Insert TITLE of invention
- (e) Insert FULL name(s) AND address(es) of declarant(s) (See headnote\*)
- (f) Insert FULL name(s) AND address(es) of actual inventor(s)
- (g) Recite how applicant(s) derive(s) title from actual inventor(s) (See headnote\*\*)
- (h) Insert country, filing date, and basic applicant(s) for the/or EACH basic application
- (k) Insert PLACE of signing
- (l) Insert DATE of signing
- (m) Signature(s) of declarant(s)

In support of the (a) Convention application made by  
 (b) A-DEC, INC.  
 an Oregon corporation located at 2601 Crestview Drive,  
 Newberg, Oregon 97132 U.S.A.  
 (hereinafter called "applicant(s)" for a patent (c) for an  
 invention entitled (d) DENTAL INSTRUMENT DELIVERY SYSTEM

I/We (e) GENE DAVIS, VICE PRESIDENT AND GENERAL MANAGER  
 2601 CRESTVIEW DRIVE  
 NEWBERG, OREGON 97132 U.S.A.

do solemnly and sincerely declare as follows:

1. ~~I am/We are the applicant(s).~~  
 (or, in the case of an application by a body corporate)
1. I am/We are authorized to make this declaration on behalf of the applicant(s).
2. ~~I am/We are the actual inventor(s) of the invention.~~  
 (or, where the applicant(s) is/are not the actual inventor(s))
2. (f) GEORGE K. AUSTIN, JR. of 12755 N.E. Parrett Mountain Road, Newberg, Oregon 97132 U.S.A., and MATHEW H. PARLIER of 18420 S. W. Sunnyridge Lane, Sheridan, Oregon 97378 U.S.A.

~~is/are~~ the actual inventor(s) of the invention and the facts upon which the applicant(s) is/~~are~~ entitled to make the application are as follows:

- (g) Applicant is the assignee of the invention from the actual inventors.

(Note: Paragraphs 3 and 4 apply only to Convention applications)

3. The basic application(s) for patent or similar protection on which the application is based ~~is/are~~ identified by country, filing date, and basic applicant(s) as follows:  
 (h) U.S. Ser. No. 101,797, filed Sept. 28, 1987 and U.S. Ser. No. 245,675, filed Sept. 20, 1988, by A-DEC, INC. as assignee from inventors GEORGE K. AUSTIN, JR. and MATHEW H. PARLIER. both in United States of America
4. The basic application(s) referred to in paragraph 3 hereof ~~was/were~~ the first application(s) made in a Convention country in respect of the invention the subject of the application.

Declared at (k) Newberg, Oregon, U.S.A.  
 Dated (l) December 20, 1988

(m) Gene Davis  
 Vice President and General Manager

To: The Commissioner of Patents

Note: No legalization or other witness required

---

**(12) PATENT ABRIDGMENT (11) Document No. AU-B-22897/88**  
**(19) AUSTRALIAN PATENT OFFICE (10) Acceptance No. 604971**

---

- (54) Title  
**DENTAL CHAIR WITH INSTRUMENT DELIVERY SYSTEM**
- International Patent Classification(s)  
(51)<sup>4</sup> **A61G 015/00**
- (21) Application No. : **22897/88** (22) Application Date : **28.09.88**
- (30) Priority Data
- | (31) Number   | (32) Date       | (33) Country                       |
|---------------|-----------------|------------------------------------|
| <b>101796</b> | <b>28.09.87</b> | <b>US UNITED STATES OF AMERICA</b> |
| <b>245675</b> | <b>20.09.88</b> | <b>US UNITED STATES OF AMERICA</b> |
- (43) Publication Date : **06.04.89**
- (44) Publication Date of Accepted Application : **03.01.91**
- (71) Applicant(s)  
**A-DEC, INC.**
- (72) Inventor(s)  
**MATHEW H. PARLIER; GEORGE K. AUSTIN JR.**
- (74) Attorney or Agent  
**PHILLIPS ORMONDE & FITZPATRICK, 367 Collins Street, MELBOURNE VIC 3000**
- (56) Prior Art Documents  
**US 4630862**  
**US 4883316**
- (57) Claim

1. A dental instrument delivery system for use with a dental chair having a seat, a back rest tiltable about a fixed horizontal axis, and means for selectively raising and lowering said chair, said system comprising:

retaining means movably attached to said back rest for holding a plurality of dental instruments in an accessible position during a dental procedure;

control means for coordinating the movement of said retaining means with the tilting of said back rest; and

safety release means for enabling said retaining means to move upward relative to said back rest when said retaining means is accidentally lowered downward onto a stationary object, whereby said safety release means prevents damage to said retaining means.

(11) AU-B-22897/88  
(10) 604971

-2-

14. A dental instrument delivery system for use with a dental chair having a seat, a tiltable back rest, and means for selectively raising and lowering said chair, said system comprising:

retaining means movably attached to said back rest for holding a plurality of dental instruments in an accessible position during a dental procedure;

control means for coordinating the movement of said retaining means with the movement of said back rest comprising a linkage cable having first and second ends, said first end being operably connected to said retaining means, with said second end being operably connected to said chair at the bottom thereof, and first and second cooperative cable guide members, said first guide member being adapted to receive said first end of said cable and operably attached to said retaining means wherein movement of said first guide member causes corresponding movement of said retaining means, said second guide member being fixedly secured to said chair at the bottom thereof and adapted to receive said second end of said cable, said first and second guide members cooperating to allow said cable to coordinate the movement of said arm with the movement of said back rest; and

safety release means for enabling said retaining means to move upward relative to said back rest when said retaining means is accidentally lowered downward onto a stationary object, whereby said safety release means prevents damage to said retaining means.

21. A dental instrument delivery system for use with a dental chair having a seat, a back rest tiltable about a fixed horizontal axis, and means for selectively raising and lowering said chair, said system comprising:

retaining means movably attached to said back rest for holding a plurality of dental instruments in an accessible position, said retaining means having an arm having a rotatable end portion comprising a plurality of instrument-holding members mounted thereon, a first section rotatably connected to said end portion, and a

(11) AU-B-22897/88  
(10) 604971

-3-

second section rotatably connected to said first section and movably attached to said tiltable back rest of said chair;

an elongate attachment member having first and second ends, said first end being pivotally attached to said back rest of said chair, and said second end being attached to said second section of said arm in a manner wherein said arm may be rotated relative to said back rest of said chair;

stop means for selectively limiting the movement of said arm relative to said back rest of said chair comprising a retractable pin fitted within said second section of said arm, said pin normally engaging said attachment member so as to limit the rotation of said arm, and the retraction of said pin allowing the rotation of said arm on said attachment member;

control means for coordinating the movement of said arm with the movement of said back rest comprising a linkage cable having first and second ends, said first end being operatively connected to said elongate attachment member, with said second end being operably connected secured to said chair at the bottom thereof, and first and second cooperative cable guide members, said first guide member being adapted to receive said first end of said cable and being fixedly secured to said elongate attachment member whereby movement of said first guide member causes corresponding movement of said attachment member, said second guide member being fixedly secured to the chair at the bottom thereof and adapted to receive said second end of said cable;

said first and second cable guide members each having a curved outer periphery, with the radius of said first guide member being identical to that of said second guide member, each of said first and second cable guide members further comprising a groove within said curved outer periphery, said groove being sized to receive said cable;

tensioning means for maintaining tension on said

(11) AU-B-22897/88  
(10) 604971

-4-

cable comprising a spring having first and second ends, said first end being operably connected to said first cable guide member, and said second end being attached to said back rest of said chair, said spring further comprising a plug member threadably engaged within said second end thereof, said plug member having an internally threaded portion receiving a cooperatively threaded attachment member for securing said plug member and said second end of said spring to said back rest of said chair;

compensator means for controlling changes in the length of said cable caused by repeated use and stretching thereof comprising a sleeve member fixedly attached to said second end of said cable, said sleeve member and attached cable being inserted through a stud mounted to said chair having an opening therein sized to receive said sleeve member, said sleeve member further comprising a threaded portion sized to receive a cooperatively threaded tension adjusting member, the tightening of said tension adjusting member against said stud causing the tension in said cable to be increased; and

safety release means for enabling said arm to move upward relative to said back rest when said arm is accidentally lowered downward onto a stationary object, said safety release means comprising said spring used to maintain tension on

said cable, said spring being operatively connected to said arm to allow the upward movement thereof.



DENTAL INSTRUMENT DELIVERY SYSTEM

5 The present invention generally relates to an apparatus mounted to a dental chair for holding dental instruments, and more particularly to such an apparatus capable of maintaining the instruments in a desired position during adjustment of the chair. Also included is a safety release feature designed to prevent damage to the apparatus and instruments  
10 if they accidentally engage a stationary object during adjustment of the chair.

Background of the Invention

15 In the practice of dentistry, it is important for the dental professional to have all of the necessary instruments in a convenient and accessible position. To facilitate access to the instruments, it is desirable that they be mounted directly on the dental chair. However, most chairs  
20 have electrical elevation systems and back rests designed to tilt upward or downward. It is therefore difficult to mount the instruments to chairs having these features.

25 Various systems have been designed to hold dental trays on a chair back in a desired position when the back is tilted. U.S. Patents 3,813,147 to Rick and 4,630,862 to Watanabe disclose systems having this capability. The Rick patent involves an instrument tray in which the tray is attached to the  
30 back rest of the chair so that the tray moves upward when the back rest is lowered. The tray includes a support unit having a parallelogram linkage mechanism which maintains the tray horizontal  
35 oriented as the back rest is moved between an

upright and reclining position. U.S. Patent  
4,630,862 to Watanabe discloses a dental chair which  
also includes an implement table maintained in a  
level position as the back rest is tilted. A  
5 complex system of linkage arms is used, which  
enables the elevation of the tray to be controlled.

To be effective, a dental instrument  
delivery system attached to the tiltable back rest  
of a chair must be capable of maintaining the  
10 instruments in a desired position while avoiding the  
use of complicated linkage systems. Since the chair  
in a dental office is the most frequently used piece  
of equipment, reliability is an important  
consideration.

15 Furthermore, it is important that the  
system be designed so that engagement of the system  
with a stationary object during adjustment of the  
chair will not result in damage to the instruments  
it carries. This problem is especially common when  
20 modern chairs are used which incorporate electrical  
means to rapidly raise and lower the chair.

The present invention involves an  
instrument delivery system which accomplishes the  
above objectives in a simple and reliable manner.  
25 Furthermore, it includes a safety release mechanism  
which prevents damage to the delivery system and  
instruments when such items accidentally engage a  
stationary object during raising and lowering of the  
chair.

30  
Summary of the Invention

~~It is an object of the invention to provide~~  
35 ~~a chair-mounted dental instrument delivery system~~  
~~which allows ready and convenient access to the~~



It is an object of the invention to overcome at least some of the problems associated with the prior art.

According to the present invention there is provided a dental instrument delivery system for use with a dental chair having a seat, a back rest tiltable about a fixed horizontal axis, and means for selectively raising and lowering said chair, said system comprising:

10 retaining means movably attached to said back rest for holding a plurality of dental instruments in an accessible position during a dental procedure;

control means for coordinating the movement of said retaining means with the tilting of said back rest; and

safety release means for enabling said retaining means to move upward relative to said back rest when said retaining means is accidentally lowered downward onto a stationary object, whereby said safety release means prevents damage to said retaining means.

20 The present invention also provides a dental instrument delivery system for use with a dental chair having a seat, a tiltable back rest, and means for selectively raising and lowering said chair, said system comprising:

retaining means movably attached to said back rest for holding a plurality of dental instruments in an accessible position during a dental procedure;

30 control means for coordinating the movement of said retaining means with the movement of said back rest comprising a linkage cable having first and second ends, said first end being operably connected to said retaining means, with said second end being operably connected to said chair at the bottom thereof, and first and second cooperative cable guide members, said first guide member being adapted to receive said first end of said cable and operably attached to said retaining means wherein movement of said first guide member causes corresponding movement of said retaining means, said second guide member being fixedly secured to said chair at the bottom thereof and adapted to receive said second end of said cable, said



first and second guide members cooperating to allow said cable to coordinate the movement of said arm with the movement of said back rest; and

safety release means for enabling said retaining means to move upward relative to said back rest when said retaining means is accidentally lowered downward onto a stationary object, whereby said safety release means prevents damage to said retaining means.

10 The present invention further provides a dental instrument delivery system for use with a dental chair having a seat, a back rest tiltable about a fixed horizontal axis, and means for selectively raising and lowering said chair, said system comprising:

20 retaining means movably attached to said back rest for holding a plurality of dental instruments in an accessible position, said retaining means having an arm having a rotatable end portion comprising a plurality of instrument-holding members mounted thereon, a first section rotatably connected to said end portion, and a second section rotatably connected to said first section and movably attached to said tiltable back rest of said chair;

an elongate attachment member having first and second ends, said first end being pivotally attached to said back rest of said chair, and said second end being attached to said second section of said arm in a manner wherein said arm may be rotated relative to said back rest of said chair;

30 stop means for selectively limiting the movement of said arm relative to said back rest of said chair comprising a retractable pin fitted within said second section of said arm, said pin normally engaging said attachment member so as to limit the rotation of said arm, and the retraction of said pin allowing the rotation of said arm on said attachment member;

control means for coordinating the movement of said arm with the movement of said back rest comprising a linkage cable having first and second ends, said first end



being operatively connected to said elongate attachment member, with said second end being operably connected secured to said chair at the bottom thereof, and first and second cooperative cable guide members, said first guide member being adapted to receive said first end of said cable and being fixedly secured to said elongate attachment member whereby movement of said first guide member causes corresponding movement of said attachment member, said second guide member being fixedly secured to the chair at the bottom thereof and adapted to receive said second end of said cable;

10

said first and second cable guide members each having a curved outer periphery, with the radius of said first guide member being identical to that of said second guide member, each of said first and second cable guide members further comprising a groove within said curved outer periphery, said groove being sized to receive said cable;

20

tensioning means for maintaining tension on said cable comprising a spring having first and second ends, said first end being operably connected to said first cable guide member, and said second end being attached to said back rest of said chair, said spring further comprising a plug member threadably engaged within said second end thereof, said plug member having an internally threaded portion receiving a cooperatively threaded attachment member for securing said plug member and said second end of said spring to said back rest of said chair;

30

compensator means for controlling changes in the length of said cable caused by repeated use and stretching thereof comprising a sleeve member fixedly attached to said second end of said cable, said sleeve member and attached cable being inserted through a stud mounted to said chair having an opening therein sized to receive said sleeve member, said sleeve member further comprising a threaded portion sized to receive a cooperatively threaded tension adjusting member, the tightening of said tension adjusting member against said stud causing the tension in

39

-4b-



said cable to be increased; and

safety release means for enabling said arm to move upward relative to said back rest when said arm is accidentally lowered downward onto a stationary object, said safety release means comprising said spring used to maintain tension on said cable, said spring being operatively connected to said arm to allow the upward movement thereof.

10 The present invention still further provides a dental instrument delivery system for use with a dental chair having a seat, a back rest tiltable about a fixed horizontal axis, and means for selectively raising and lowering said chair, said system comprising:

retaining means movably attached to said back rest for holding a plurality of dental instruments in an accessible position during a dental procedure;

control means for coordinating the movement of said retaining means with the tilting of said back rest;

20 first safety release means for enabling said retaining means to move upward relative to said back rest when said retaining means is accidentally lowered downward onto a stationary object, whereby said first safety release means prevents damage to said retaining means; and

second safety release means for enabling said retaining means to move downward relative to said back rest when said retaining means is accidentally raised upward against a stationary object, whereby said second safety release means prevents damage to said retaining means.

30 Accordingly, there is provided a dental instrument delivery system mounted to the rear of a dental chair which includes an articulated instrument retaining arm adjustable in a plurality of directions and positions. This capacity enables the dental instruments held by the system to be readily available at all times. The arm is connected to a mechanism within the back rest of a dental chair which allows the instruments held



5 by the arm to remain in the same plane as the back  
rest is tilted. This prevents the instruments from  
tilting during adjustment of the back rest. The  
mechanism uses a single control cable and eliminates  
10 the need for complex mechanical linkages. Included  
within the mechanism is a safety release system  
which enables the retaining arm to move upward  
relative to the back rest of the chair should it  
accidentally engage a solid object when the back  
15 rest is lowered. Likewise, the safety release  
system enables the retaining arm to move downward  
relative to the chair back rest should it engage a  
solid object when the back rest is raised. All of  
these features cooperate to produce a dental  
instrument delivery system of superior efficiency  
and design.

20 Further objects, features and advantages of  
the invention will be described in the following  
drawings and detailed description of a preferred  
embodiment.

#### Brief Description of the Drawings

25 Fig. 1 is a perspective view of the  
instrument retaining arm and supporting mechanism of  
the invention attached to a dental chair having  
portions cut away to illustrate the construction of  
the arm;

30 Fig. 2 is an enlarged perspective view of  
the flattened end of the retaining arm, and the  
spring-biased control mechanism associated  
therewith;

35 Fig. 3 is a fragmentary side view, partly  
in section, of a dental chair back rest and the  
mechanism used to coordinate movement of the

retaining arm with the back rest;

Fig. 4 is a fragmentary view from below of the apparatus used to mount the retaining arm to the back rest with the back rest not shown;

5 Fig. 5 is a fragmentary side view partly in section of a dental chair and the mounting mechanism for the instrument retaining arm, the solid lines illustrating the position of the mechanism when the back rest is in an upright position, with the dashed  
10 lines illustrating the mechanism after the back rest has been tilted downward; and

Fig. 6 is a fragmentary side view of an additional embodiment of the dental instrument delivery system showing the mechanism used to  
15 prevent damage to the retaining arm should it accidentally engage a stationary object during upward movement of the back rest.

20 Detailed Description of Preferred Embodiment

With reference to Fig. 1, the invention is generally illustrated in association with a chair  
25 of conventional design. The chair 12 includes a back rest 14 which may be tilted either manually or by motor drive in a continuous range of motion from a vertical to horizontal position.

The instrument delivery system of the invention basically consists of two main components. The first component comprises an articulated arm 22 made of a strong, light material  
30 (preferably brushed aluminum). As illustrated in Fig. 1, the arm 22 includes an elongate horizontally extending end portion 24 to which a selected plurality of semi-circular instrument retaining  
35 members 26 are secured by screws or other

conventional fasteners. Although three retaining members 26 are shown in the illustrated embodiment, the number may vary as desired. The retaining members 26 each have an open region 28 sized for insertion of a selected dental instrument 36. Such dental instruments may include syringes, and vacuum-operated suction devices. Connected to each dental instrument 36 is a supply line 40 which communicates with a suitable vacuum or water source.

The end portion 24 of the arm 22 is rotatably mounted within an opening 42 in the end of a horizontal portion 44 of a right-angled medial section 46. The end portion 24 is maintained in position within the opening 42 of the medial section 46 by an adjusting screw 48. The screw 48 extends into a groove 50 (Fig. 1) to prevent the accidental removal of the end portion 24 from the medial section 46.

The medial section 46 includes a downwardly extending portion 51 having an axial opening 52 adapted to receive a pin 56 at the end 58 of a connecting section 60. The medial section 46 is rotatable relative to the connecting section 60 about pin 56. The ease of rotation between these two components is controlled by the frictional engagement of a screw 64 in the medial section 46 adapted to engage the surface of pin 56 at a selected pressure.

The connecting section 60 is also bent in a right angle as shown in Fig. 1, with the end opposite end 58 terminating in a flattened portion 66 (Figs. 1 and 2). The flattened portion 66 of the connecting section 60 is rotatably secured by a vertically oriented screw 67 or other conventional fastener to the angled, horizontally extending

surface 76 of an elongate attachment member 78 (Figs. 3 and 4). This construction enables the arm 22 to be rotated about a vertical axis regardless of the position of the back rest 14.

5           The attachment member 78 further includes beveled edges 80, 82 and a medial edge 83 which cooperate with a spring biased control mechanism 70 in the connecting section 60. The control mechanism 70 enables arm 22 to be fixed in position either  
10           directly behind the chair 12 or on either side of the chair 12.

          The control mechanism 70 includes a button 72, and a retractable stop member 74. When the stop member 74 is in an operative position, it will abut  
15           one of the edges 80, 82 or 83 (depending on where the arm 22 is positioned) and will secure the arm 22 in the selected position. Fig. 4 shows the stop member 74 in abutting engagement with edge 80.  
          However, if movement to another position is desired,  
20           the button 72 is depressed, causing retraction of the stop member 74 within the arm 22 against a spring (not shown) mounted therein. This allows the arm 22 to be rotated to a position directly behind the back rest 14 or on either side of the chair 12.

25           The second major component of the invention consists of the mechanism used to coordinate movement of the arm 22 with the tilting movement of back rest 14. Secured within the back rest 14 of the chair 12 is a support block 84 as illustrated in Figs. 3 and 4. The bottom portion 85 of the support block 84 includes a plurality of vacuum line  
30           connectors 88 communicating with a main vacuum pipe 90 on the side of the support block 84. Pipe 90 is connected to a conventional vacuum source known in  
35           the art. The connectors 88 are designed for the

attachment of supply lines 40 which lead to the dental instruments 36 as described above.

5 Affixed to and extending from opposite sides of the attachment member 78 are pins 94, 95 pivotally mounted within the central portion 92 of the support block 84 as illustrated in Figs. 3 and 4. The pins 94, 95 pivot in openings 96 on each side of the support block 84 (Fig. 4). Plastic bushings 98 line the openings 96.

10 As illustrated in Fig. 3, pin 94 of the attachment member 78 is fixedly secured to an upper guide member 100. The guide member 100 has a curved peripheral edge 102 having a groove 104 therein coaxial with the axis of pins 94, 95. Since the pin 15 94 of the attachment member 78 is fixedly secured to the guide member 100, pivotal movement of the guide member 100 produces corresponding movement of the attachment member 78, as will be further described below.

20 Pivotaly attached at position 106 on the guide member 100 using a fastener 108 is one end of a connecting bar 110 (Fig. 3). The fastener 108 passes through an opening (not shown) in the bar 110. Inserted through an opening 114 at the 25 opposite end 116 of the bar 110 is the end 117 of a coil spring 118. Into the opposite end 120 of the spring 118, as shown in Fig. 4, an externally threaded plug 126 is positioned. The plug 126 has a threaded opening 127 in the end thereof for 30 receiving a mounting screw 128 extending through a bracket 132 fixed to the back rest 14 (Fig. 5). This construction enables the spring 118 to be easily mounted and removed as desired, without exerting excessive contractive or expansive force on 35 the spring. The function of spring 118 will be more

fully explained hereinafter.

5           Positioned within the groove 104 of the upper guide member 100 is a cable 136 shown in Figs. 3 and 4. The upper first end 138 of the cable 136 is positioned beneath a retaining screw 140 extending transversely through the guide member 100 and above the groove 104 as illustrated in Fig. 3. A spherical locking member 144 known in the art is attached to the end 138 of the cable 136 to prevent  
10           the end 138 from passing under the screw 140 and out of the groove 104. This arrangement insures that the cable 136 is always maintained in a proper position within the groove 104.

15           The cable 136 passes downwardly along the back rest 14 through an intermediate guide member 152 having a bore 154 sized to allow free movement of the cable 136 therethrough. As shown in Figs. 3 and 4, beneath the guide member 152, the cable 136 extends through a tubular outer sheath 160 fixed to the guide member 152.  
20

            With reference to Fig. 5, the lower end 170 of the sheath 160 is fixedly secured to a cylindrical stop member 172. The stop member 172 includes a bore 173 sized to retain the sheath 160 therein, while allowing free passage of the lower, second end 176 of the cable 136 therethrough. The stop member 172 is suitably attached to the lower  
25           frame 175 of the back rest 14 of the chair 12.

            The second end 176 of the cable 136 is positioned within a groove 178 in the peripheral edge 180 of a disc-shaped lower guide member 182. The guide member 182 is suitably secured to the chair 12 coaxially with the pivot axis 184 between the back rest 14 and the seat 185. Also, the guide  
30           member 182 has the same radius as that of the guide  
35

member 100.

5 With continued reference to Fig. 5, the  
second end 176 of the cable 136 further includes a  
cylindrical sleeve 186 permanently secured thereto.  
The sleeve 186 has a threaded portion 190 which  
10 extends through an opening 192 in a stud 194 fixedly  
secured to the chair 12 adjacent the guide member  
182. The opening 192 is sized to allow free passage  
of the sleeve 186 therethrough. A nut 200 is  
15 threaded onto the threaded portion 190 beneath the  
stud 194.

15 Fig. 6 shows another embodiment of the  
invention which incorporates a system for preventing  
damage to the arm 22 and instruments it carries  
should the arm 22 engage a solid object during  
upward movement of the back rest 14. Upward  
movement of the back rest 14 typically occurs by  
either tilting of the back rest 14 to adjust its  
angular position or by moving the entire chair 12  
upward. Specifically, an enlarged stud 300 is  
20 provided having an opening 302 therethrough. The  
stud 300 is fixedly secured to the chair 12 adjacent  
the guide member 182. Adjacent the opening 302 is a  
substantially flat face 304 which is preferably  
perpendicular to the longitudinal axis 306 of the  
25 opening 302. The opening 302 is sized to freely  
receive the sleeve 186 therethrough. After passage  
of the sleeve 186 through the opening 302, a spring  
310 having a diameter greater than that of the  
sleeve 186 is placed over the threaded portion 190  
30 of the sleeve 186. The front 312 of the spring 310  
is designed to engage the face 304 of stud 300. A  
nut 313 is then threaded onto the threaded portion  
190 of the sleeve 186, engaging the rear 314 of the  
35 spring 310.

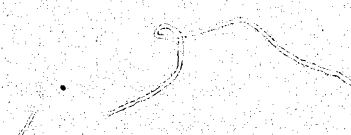
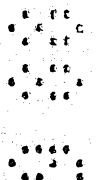

Operation

5 Operation of the instrument delivery system of the invention is illustrated in Fig. 5. The portions of Fig. 5 in solid lines show the system in a semi-upright position on the back rest 14, with the dashed lines showing the system after the back rest 14 is tilted downward.

10 When the back rest 14 is tilted downward, the arm 22 correspondingly rotates relative to the back rest 14 so that the arm 22 remains horizontal, and the instruments 36 held by the arm 22 remain in the same relative position. If the instruments 36 are in a substantially vertical orientation as shown in Fig. 1, they will remain in such orientation when the back rest 14 is tilted downward. This enables the instruments to be readily accessible at all times in the orientation desired by the dentist.

15 As the back rest 14 tilts, the second end 176 of cable 136 between the stud 194 and stop member 172 bends over and around the lower guide member 182 within the groove 178 (see dashed lines in Fig. 5). Since the nut 200 on the second end 176 of cable 136 engages the stud 194, tension is generated in the cable 136 which is transmitted to the first end 138 of the cable 136 to rotate the guide member 100 against the action of the spring 118 to which it is connected.

20 As the back rest 14 tilts and upper guide member 100 rotates, the attachment member 78 remains in the same angular position relative to the floor. However, the attachment member 78 tilts relative to the back rest 14 so as to cause arm 22 to remain horizontal and the instruments thereon to remain in a desired position. This result is shown in Fig. 5 by the position of attachment member 78 relative to

25

30

35

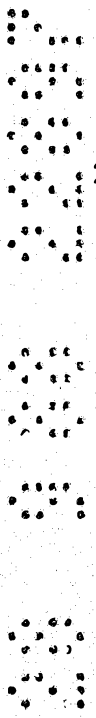

horizontal plane 210. Such position remains the same both before and after movement of the back rest 14 as illustrated in Fig. 5.

5 The system operates in a reverse manner from that described above when the chair back rest 14 is moved upward, and achieves the same ultimate result.

10 The cooperative action of the upper and lower guide members 100, 182 is important in maintaining the instruments on the arm 22 in their desired position. Since members 100, 182 have an identical radius, the cable 136 causes the rotation of upper guide member 100 in an amount equal to the movement of cable 136 around the lower guide member 182. As a result, the attachment member 78 and arm 22 remain in the same relative position regardless of the tilting of back rest 14.

15  
20  
25  
30  
35  
In addition, should the arm 22 engage a solid object when the chair 12 is lowered as back rest 14 is tilted, the force exerted against the arm 22 will be transmitted to the attachment member 78 causing it to rotate relative to the back rest 14. As the attachment member 78 rotates, corresponding rotational movement is conveyed to the upper guide member 100 to which it is attached, causing the guide member 100 to rotate against the bias of spring 118. This enables the arm 22 to move when it strikes a solid object. When the chair 12 or back rest 14 is raised to clear the arm 22 from the engaged object, the arm 22 will return to its original position through the pulling action of the spring 118 against the upper guide member 100 to which the attachment member 78 and arm 22 are secured.

Should the cable 136 ever become

permanently stretched due to repeated use, the nut 200 on the second end 176 of cable 136 can be rotated inward along the sleeve 186, increasing the tension of the cable 136 as necessary.

5 In the embodiment of Fig. 6, the arm 22 is capable of movement in the same manner as the embodiment of Figs. 1 - 5 should it strike a solid object when the chair 12 and/or back rest 14 is lowered. The embodiment of Fig. 6 also includes a system for preventing damage to the arm 22 and the instruments which it carries should they engage a solid object when the chair 12 and/or back rest 14 are raised upward. Specifically, the force exerted against the arm 22 during engagement is transmitted to the attachment member 78 causing it to rotate relative to the back rest 14. This rotation is opposite in direction to the rotation which occurs when the arm 22 strikes a solid object as the chair 12/back rest 14 is lowered downward. As the attachment member 78 rotates, it pulls upward on the cable 136, sleeve 186, and nut 313. Since the sleeve 186 is designed to freely move within the opening 302 of the stud 300, the nut 313 is urged toward the stud 300, further compressing the spring 310 therebetween. The ability of the nut 313 to move inward toward the stud 300 enables the arm 22 to move when it strikes an object during upward movement of the chair 12/back rest 14. When the arm 22 clears the engaged object, it will return to its original position through the decompressive action of spring 310 against the nut 313.

10  
15  
20  
25  
30  
35 It should also be noted that the nut 313 is threadably adjustable along the sleeve 186 in order to selectively increase or decrease the compression of spring 310 between nut 313 and stud 300.

Decreasing the compression of spring 310 consequently decreases the resistance exerted by arm 22 against a solid object when engagement between the two occurs. An opposite effect occurs when the compression of spring 310 is increased. Furthermore, should cable 136 ever become permanently stretched due to repeated use, the nut 312 can be rotated inward along sleeve 186 in order to compensate for the increased length of the cable 136 due to stretching.

Having herein described a preferred embodiment of this invention, it is apparent that suitable modifications may be made by those skilled in the art within the scope of the present invention. The invention is therefore to be construed in accordance with the following claims.

15

20

25

30

35

The claims defining the invention are as follows:

1. A dental instrument delivery system for use with a dental chair having a seat, a back rest  
5 tiltable about a fixed horizontal axis, and means for selectively raising and lowering said chair, said system comprising:

retaining means movably attached to said back rest for holding a plurality of dental  
10 instruments in an accessible position during a dental procedure;

control means for coordinating the movement of said retaining means with the tilting of said back rest; and

15 safety release means for enabling said retaining means to move upward relative to said back rest when said retaining means is accidentally lowered downward onto a stationary object, whereby  
20 said safety release means prevents damage to said retaining means.

2. The system of claim 1 wherein said retaining means comprises an arm having an end  
25 portion having at least one instrument-holding member mounted thereon, a first section connected to said end portion, and a second section connected to said first section and movably attached to said  
tiltable back rest of said chair.

3. The system of claim 2 wherein said second section of said arm further comprises stop  
30 means for selectively limiting the movement of said arm relative to said back rest of said chair.

4. The system of <sup>claim 2 or</sup> claim 3 further

35



comprising an elongate attachment member having first and second ends, said first end being pivotally attached to said back rest of said chair, and said second end being attached to said second section of said arm in a manner wherein said arm may be rotated relative to said back rest of said chair.

5

5. The system of claim 4 wherein said stop means comprises a retractable pin fitted within said second section of said arm, said pin normally engaging said attachment member so as to limit the rotation of said arm, and the retraction of said pin allowing the rotation of said arm on said attachment member.

10

15

6. The system of claim 4 <sup>or claim 5</sup> wherein said control means comprises:

a linkage cable having first and second ends, said first end being operably connected to said elongate attachment member, and said second end being operably connected to said chair at the bottom thereof; and

20

first and second cooperative cable guide members, said first guide member being adapted to receive said first end of said cable and fixedly secured to said elongate attachment member wherein movement of said first guide member causes corresponding movement of said attachment member, said second guide member being fixedly secured to said chair at the bottom thereof and adapted to receive said second end of said cable, said first and second guide members cooperating to allow said cable to coordinate the movement of said arm with the movement of said back rest.

25

30

35



7. The system of claim 6 wherein said first and second cable guide members each have a curved outer periphery, with the radius of said first guide member being identical to that of said second guide member, each of said first and second cable guide members further comprising a groove within said curved outer periphery, said groove being sized to receive said cable.

8. The system of claim 6 or claim 7 further comprising tensioning means for maintaining tension on said cable.

10 9. The system of claim 8 wherein said tensioning means comprises a spring having first and second ends, said first end being operably connected to said first cable guide member, and said second end being attached to said back rest of said chair.

20 10. The system of claim 9 further comprising a plug member threadably engageable within said second end of said spring, said plug member having an internally threaded portion sized to receive a cooperatively threaded attachment member for securing said plug member and said second end of said spring to said back rest of said chair.

11. The system of any one of claims 6 to 10 further comprising compensator means for controlling changes in the length of said cable caused by repeated use and stretching thereof.

30 12. The system of any one of claims 6 to 11 wherein said second end of said cable is secured within a sleeve member, said sleeve member and attached cable being inserted through a stud mounted to said chair having an opening therein sized to receive said sleeve member, said sleeve member having a threaded portion sized to receive a cooperatively threaded tension adjusting member, the tightening of said tension adjusting member against said stud causing the tension in said cable to be increased.

13. The system of any one of claims 1 to 12 wherein said safety release means comprises a spring operably connected to said retaining means for allowing the upward movement of said retaining means.

14. A dental instrument delivery system for use with a



dental chair having a seat, a tiltable back rest, and means for selectively raising and lowering said chair, said system comprising:

retaining means movably attached to said back rest for holding a plurality of dental instruments in an accessible position during a dental procedure;

control means for coordinating the movement of said retaining means with the movement of said back rest comprising a linkage cable having first and second ends, 10 said first end being operably connected to said retaining means, with said second end being operably connected to said chair at the bottom thereof, and first and second cooperative cable guide members, said first guide member being adapted to receive said first end of said cable and operably attached to said retaining means wherein movement of said first guide member causes corresponding movement of said retaining means, said second guide member being fixedly secured to said chair at the bottom thereof and adapted to receive said second end of said cable, said 20 first and second guide members cooperating to allow said cable to coordinate the movement of said arm with the movement of said back rest; and

safety release means for enabling said retaining means to move upward relative to said back rest when said retaining means is accidentally lowered downward onto a stationary object, whereby said safety release means prevents damage to said retaining means.

15. The system of claim 14 wherein said safety release means comprises a spring operably connected to said retaining means for allowing the upward movement of said retaining means. 30

16. The system of claim 14 or claim 15 wherein said first and second cable guide members each have a curved outer periphery, with the radius of said first guide member being identical to that of said second guide member, each of said first and second cable guide members further comprising a groove within said curved outer periphery, said groove being sized to receive said cable.



17. The system of any one of claims 14 to 16 further comprising tensioning means for maintaining tension on said cable comprising a spring having first and second ends, said first end being operably connected to said first cable guide member, and said second end being attached to said back rest of said chair.

10 18. The system of claim 17 further comprising a plug member threadably engageable within said second end of said spring, said plug member having an internally threaded portion sized to receive a cooperatively threaded attachment member for securing said plug member and said second end of said spring to said back rest of said chair.

19. The system of any one of claims 14 to 18 further comprising compensator means for controlling changes in the length of said cable caused by repeated use and stretching thereof.

20 20. The system of any one of claims 14 to 19 wherein said second end of said cable is secured within a sleeve member, said sleeve member and attached cable being inserted through a stud mounted to said chair having an opening therein sized to receive said sleeve member, said sleeve member having a threaded portion sized to receive a cooperatively threaded tension adjusting member, the tightening of said tension adjusting member against said stud causing the tension in said cable to be increased.

21. A dental instrument delivery system for use with a dental chair having a seat, a back rest tiltable about a fixed horizontal axis, and means for selectively raising and lowering said chair, said system comprising:

30 retaining means movably attached to said back rest for holding a plurality of dental instruments in an accessible position, said retaining means having an arm having a rotatable end portion comprising a plurality of instrument-holding members mounted thereon, a first section rotatably connected to said end portion, and a second section rotatably connected to said first section and movably attached to said tiltable back rest of said chair;

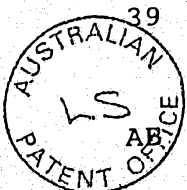

an elongate attachment member having first and second ends, said first end being pivotally attached to said back rest of said chair, and said second end being attached to said second section of said arm in a manner wherein said arm may be rotated relative to said back rest of said chair;

10 stop means for selectively limiting the movement of said arm relative to said back rest of said chair comprising a retractable pin fitted within said second section of said arm, said pin normally engaging said attachment member so as to limit the rotation of said arm, and the retraction of said pin allowing the rotation of said arm on said attachment member;

20 control means for coordinating the movement of said arm with the movement of said back rest comprising a linkage cable having first and second ends, said first end being operatively connected to said elongate attachment member, with said second end being operably connected secured to said chair at the bottom thereof, and first and second cooperative cable guide members, said first guide member being adapted to receive said first end of said cable and being fixedly secured to said elongate attachment member whereby movement of said first guide member causes corresponding movement of said attachment member, said second guide member being fixedly secured to the chair at the bottom thereof and adapted to receive said second end of said cable;

30 said first and second cable guide members each having a curved outer periphery, with the radius of said first guide member being identical to that of said second guide member, each of said first and second cable guide members further comprising a groove within said curved outer periphery, said groove being sized to receive said cable;

tensioning means for maintaining tension on said cable comprising a spring having first and second ends, said first end being operably connected to said first cable guide member, and said second end being attached to

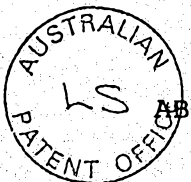

said back rest of said chair, said spring further comprising a plug member threadably engaged within said second end thereof, said plug member having an internally threaded portion receiving a cooperatively threaded attachment member for securing said plug member and said second end of said spring to said back rest of said chair;

10 compensator means for controlling changes in the length of said cable caused by repeated use and stretching thereof comprising a sleeve member fixedly attached to said second end of said cable, said sleeve member and attached cable being inserted through a stud mounted to said chair having an opening therein sized to receive said sleeve member, said sleeve member further comprising a threaded portion sized to receive a cooperatively threaded tension adjusting member, the tightening of said tension adjusting member against said stud causing the tension in said cable to be increased; and

20 safety release means for enabling said arm to move upward relative to said back rest when said arm is accidentally lowered downward onto a stationary object, said safety release means comprising said spring used to maintain tension on

30



39

AB

said cable, said spring being operatively connected to said arm to allow the upward movement thereof.

22  
~~23~~

5 A dental instrument delivery system for use with a dental chair having a seat, a back rest tiltable about a fixed horizontal axis, and means for selectively raising and lowering said chair, said system comprising:

10 retaining means movably attached to said back rest for holding a plurality of dental instruments in an accessible position during a dental procedure;

15 control means for coordinating the movement of said retaining means with the tilting of said back rest;

20 first safety release means for enabling said retaining means to move upward relative to said back rest when said retaining means is accidentally lowered downward onto a stationary object, whereby said first safety release means prevents damage to said retaining means; and

25 second safety release means for enabling said retaining means to move downward relative to said back rest when said retaining means is accidentally raised upward against a stationary object, whereby said second safety release means prevents damage to said retaining means.

30  
~~24~~

35 The system of claim 22 wherein said retaining means comprises an arm having an end portion having at least one instrument-holding member mounted thereon, a first section connected to said end portion, and a second section connected to said first section and movably attached to said tiltable back rest of said chair.



5                   <sup>24</sup>  
~~23~~. The system of claim, <sup>23</sup>~~24~~ further  
comprising an elongate attachment member having  
first and second ends, said first end being  
pivotally attached to said back rest of said chair,  
and said second end being attached to said second  
section of said arm in a manner wherein said arm may  
be rotated relative to said back rest of said chair.

10                   <sup>25</sup>  
~~24~~. The system of claim, <sup>24</sup>~~25~~ further  
comprising a linkage cable having first and second  
ends, said first end being operably connected to  
said elongate attachment member, and said second end  
being operably connected to said chair at the bottom  
thereof.

15                   <sup>26</sup>  
~~25~~. The system of claim, <sup>25</sup>~~26~~ wherein said  
control means comprises first and second cooperative  
cable guide members, said first guide member being  
adapted to receive said first end of said cable and  
fixedly secured to said elongate attachment member  
wherein movement of said first guide member causes  
corresponding movement of said attachment member,  
said second guide member being fixedly secured to  
said chair at the bottom thereof and adapted to  
20                   receive said second end of said cable, said first  
and second guide members cooperating to allow said  
cable to coordinate the movement of said arm with  
the movement of said back rest.

25                   <sup>27</sup>  
~~26~~. The system of claim, <sup>26</sup>~~27~~ wherein said  
first and second cable guide members each have a  
curved outer periphery, with the radius of said  
first guide member being identical to that of said  
second guide member, each of said first and second  
cable guide members further comprising a groove  
30                   



within said curved outer periphery, said groove being sized to receive said cable.

28. The system of any one of claims 25 to 27 further comprising tensioning means for maintaining tension on said cable.

29. The system of claim 28 when appended to claims 26 or 27 wherein said tensioning means comprises a spring having first and second ends, said first end being operably connected to said first cable guide member, and said  
10 second end being attached to said back rest of said chair.

30. The system of claim 29 further comprising a plug member threadably engageable within said second end of said spring, said plug member having an internally threaded portion sized to receive a cooperatively threaded attachment member for securing said plug member and said second end of said spring to said back rest of said chair.

31. The system of any one of claims 22 to 30 wherein said first safety release means comprises a spring operably connected to said retaining means for allowing  
20 the upward movement of said retaining means.

32. The system of any one of claims 25 to 31 wherein said second safety release means comprises:

a sleeve member secured to said second end of said cable having a threaded portion thereon;

a stud mounted to said chair having an opening therein sized to movably receive said sleeve member;

a tension adjusting member threadably engageable with said threaded portion of said sleeve member; and

a biasing member positioned on said sleeve member  
30 between said stud and said tension adjusting member.

33. The system of claim 32 wherein said biasing member comprises a spring.

34. The system of claim 1, substantially as herein described with reference to the accompanying drawings.

DATED: 20 SEPTEMBER, 1990

PHILLIPS ORMONDE & FITZPATRICK

Attorneys For:

A-DEC, INC.

2294Z

*David B Fitzpatrick*

-25-



22897/86

FIG. 1

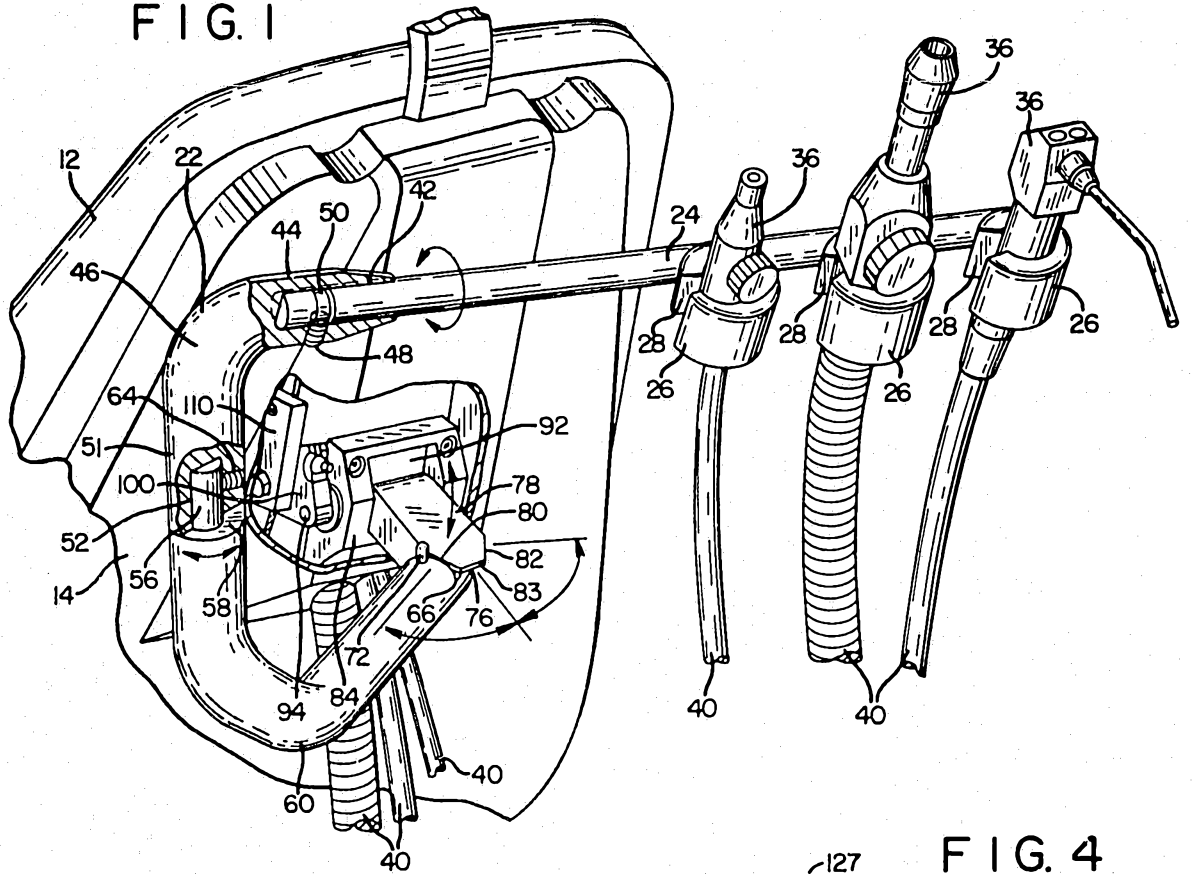

FIG. 3

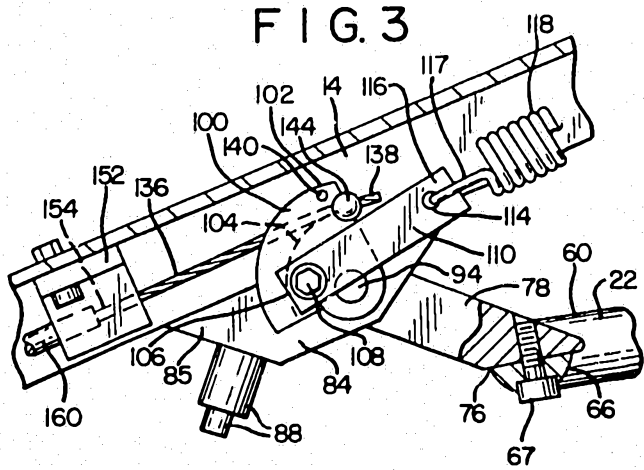

FIG. 4

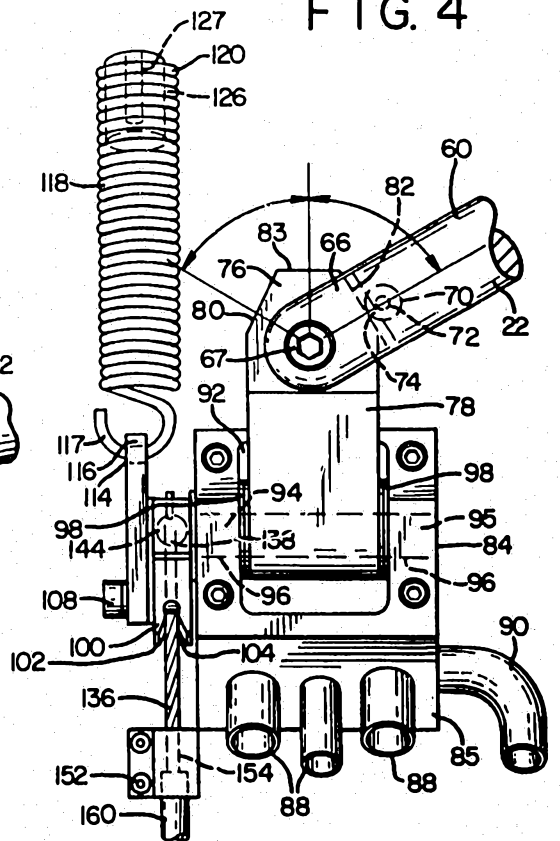

FIG. 2

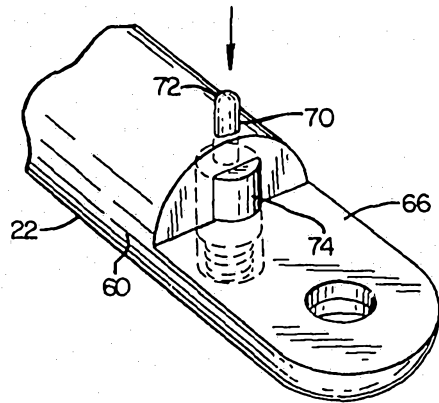

FIG. 5

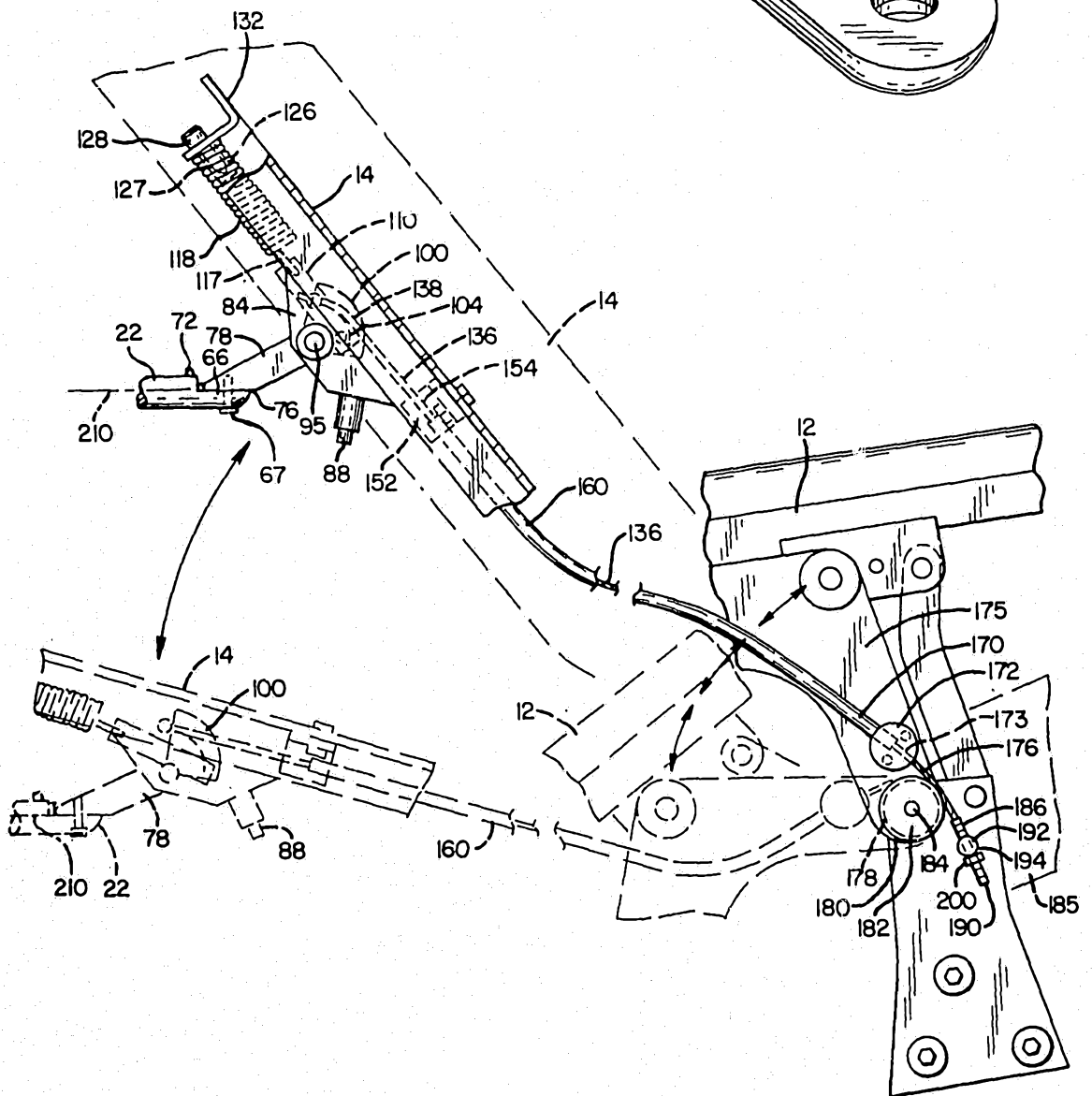

FIG. 6

