

G. V. MILLER.  
TROLLEY.  
APPLICATION FILED APR. 7, 1905.

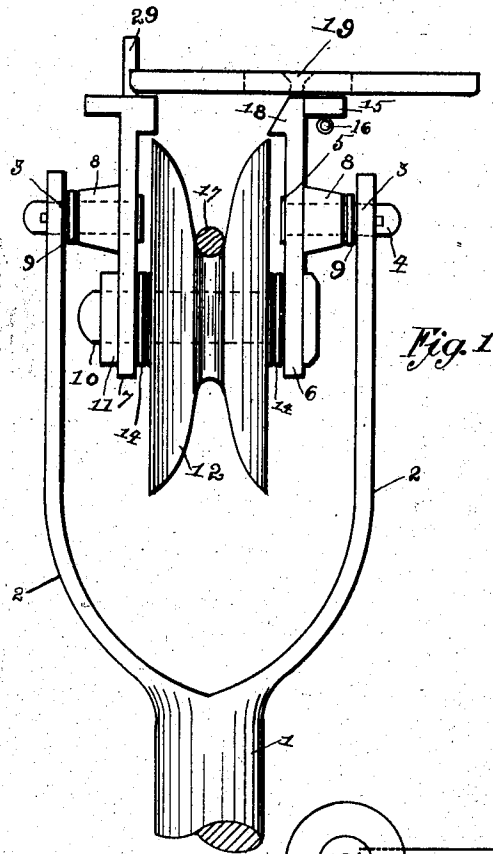

Fig. 1

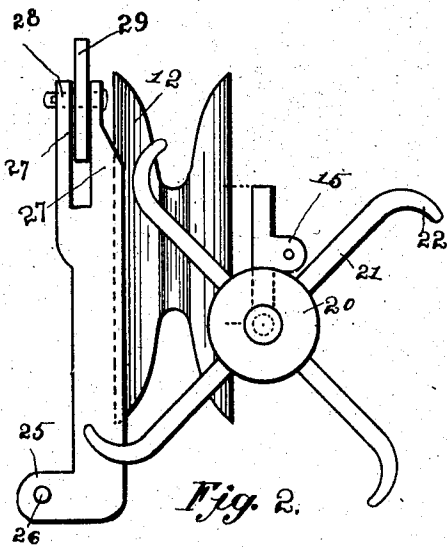

Fig. 2.

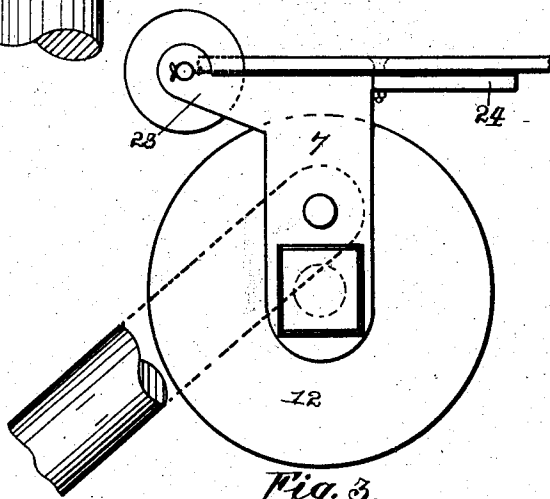

Fig. 3.

Witnesses.

C. A. Rudolph.  
H. N. Butler.

Inventor  
G. V. Miller.

By A. C. Everett & Co.  
Attorneys.

# UNITED STATES PATENT OFFICE.

GEORGE V. MILLER, OF IRWIN, PENNSYLVANIA.

## TROLLEY.

SPECIFICATION forming part of Letters Patent No. 791,279, dated May 30, 1905.

Application filed April 7, 1905. Serial No. 254,288.

*To all whom it may concern:*

Be it known that I, GEORGE V. MILLER, a citizen of the United States of America, residing at Irwin, in the county of Westmoreland and State of Pennsylvania, have invented certain new and useful Improvements in Trolleys, of which the following is a specification, reference being had therein to the accompanying drawings.

This invention relates to certain new and useful improvements in trolleys; and the object of the invention is to provide a novel device for preventing a trolley wheel or wire from becoming displaced when cars or vehicles carrying the trolley pass around curves at considerable speed or pass beneath bridges.

Another object of this invention is to provide a novel device that can be readily used in connection with the ordinary type of trolley-pole, and I have embodied certain features of construction which will insure positive engagement of the trolley-wheel and the trolley-wire, also novel means for protecting and preventing the trolley from striking overhead work, such as guide-wires and guard-boards constructed under bridges.

The invention finally consists in the novel construction, combination, and arrangement of parts, which will be hereinafter more fully described and then specifically pointed out in the claims, and, referring to the drawings accompanying this application, like numerals of reference designate corresponding parts throughout the several views, in which—

Figure 1 is a front elevation of my improved trolley. Fig. 2 is a top plan view of the same. Fig. 3 is a side elevation view of the trolley.

To put my invention into practice, I employ an ordinary trolley-pole 1, the arms 2 2 of the harp of said pole being separated sufficiently to accommodate my improved construction. The upper end of each arm 2 is provided with an aperture 3, in which is mounted a pin 4, carrying a head 5. Mounted upon the pins 4 4, adjacent to the heads thereof, are plates 6 and 7, each plate being provided with an outwardly-extending boss 8, and between said bosses and the arms 2 2 I provide washers 9 9.

In the lower ends of the plates 6 and 7 is

mounted a bolt 10, which is retained in engagement with the plates by a nut 11. Journalled upon the bolt is a trolley-wheel 12, and interposed between said wheel and the plates 6 and 7 are washers 14 14.

The upper end of the plate 6 is provided with an outwardly-extending lug 15, carrying a depending eyelet 16, in which a trolley-rope may be secured, whereby the trolley-wheel can be manipulated to remove the trolley-wheel 12 from the wire 17. The upper end of the plate 6 is provided with an inwardly-projecting lug 18, adapted to extend into close proximity to the periphery of the trolley, and upon the top of the plate 6 is horizontally-journalled, by a screw 19, a pronged wheel 20. In the present illustration this wheel is shown as consisting of four prongs 21, diametrically opposed to one another, and the outer end of each prong is bent forward, as indicated at 22.

The top of the plate 7 is provided with a forwardly-extending bracket 23 and a rearwardly-extending arm 24, the extreme end of the arm being bent outwardly, as indicated at 25, and pierced, as indicated at 26, to receive the end of a trolley-rope. It is the practice to splice a piece of rope upon the end of the ordinary trolley-rope and then secure the two ends of the rope upon each side of the trolley-wheel, and the end 25 of the arm 24 and the depending eyelet 16 can be readily used for securing the ends of the trolley-rope. The bracket 23 is bifurcated to provide arms 27 27, and the extreme ends of these arms are pierced to receive a pin 28. Upon the pin 28 is mounted a wheel 29, the object of which will be presently described.

Before describing the operation of my improved device I desire to call attention to the arrangement of its appurtenant parts. By referring to Fig. 2 of the drawings it will be observed that the prongs 21 of the horizontally-positioned wheel 20 lie over the trolley-wheel 12 and partly over the plate 7. I have used a sufficient number of prongs to at all times insure the location of one of said prongs over said trolley-wheel, whereby should the wheel become displaced from the wire the wire

cannot become disengaged from my improved device.

In operation should the rapidity of a car or vehicle increase to such an extent as to cause the trolley-wheel 12 to become displaced the trolley-wire will be held by one of the prongs of the wheel 20 and will be returned to its normal position by the lug 18 and the plate 7. I have pivotally mounted the wheel 20 and provided the same with prongs whereby when the hangers or mushrooms of overhead construction are encountered my improved device will be permitted to pass such construction without giving the trolley-wheel 12 a chance to become displaced from the wire.

In order to allow the passage of my improved device beneath bridges where guard-boards are encountered, I have provided the wheel 29, the periphery of which is adapted to travel upon the guard-board and retain the trolley and my improved device at a sufficient height that it will be free to operate and will not encounter the guard-board. When crossing-switches, crossover guide-wires, and the like overhead constructions are encountered, the wheel 29 throws the wheel 20 below the trolley-wire, this being accomplished in the following manner: Owing to the upward movement of the trolley-pole 1 occasioned by the springs generally used in connection with trolley-poles at the base thereof, the harp acts as a fulcrum for the plates 6 and 7, and these plates are permitted to turn upon the pin 4, causing the prongs of the wheel 20 to strike the trolley-wire as it moves downwardly, and the wheel will rotate, allowing it to pass beneath the wire. After the impediment has been passed the upward movement of the pole throws the plates 6 and 7 rearwardly into place, the wheel 20 mounting the wire similar to its downward movement.

The device as above described consists of very few parts, any of which can be easily renewed should they accidentally become broken, and each part is constructed to perform a certain function, which, together with the functions of the other parts, will at all

times retain a trolley-wheel upon a trolley-wire.

While I have herein described the preferred manner of constructing my improved device, it is obvious that various changes may be made in the details of construction without departing from the general spirit and scope of the invention.

What I claim, and desire to secure by Letters Patent, is—

1. In a trolley of the type described, the combination with a pole and harp, of plates mounted in said harp, a pin carried by the lower ends of said plates, a trolley-wheel journaled upon said pin, a revoluble wheel horizontally mounted upon the upper end of one of said plates, prongs carried by the periphery of said wheel, a revoluble wheel mounted in the upper end of the other of said plates, inwardly-extending lugs carried by the upper ends of said plates, substantially as described.

2. In a trolley of the type described, the combination with a trolley pole and harp, of plates mounted in said harp, a wheel journaled between said plates, a revoluble wheel horizontally mounted upon one of said plates prongs carried by the periphery of said wheel and adapted to overlie the first-named wheel, a wheel journaled in the other of said plates and adapted to extend above the second-named wheel, substantially as described.

3. In a trolley of the type described, the combination with a trolley pole and harp, of plates mounted in said harp, a wheel journaled between said plates, a wheel horizontally mounted above the first-named wheel, and a wheel revolubly mounted adjacent to the second-named wheel and extending above said wheel, substantially as and for the purpose described.

In testimony whereof I affix my signature in the presence of two witnesses.

GEORGE V. MILLER.

Witnesses:

F. M. CARSON,  
J. E. IRWIN.