

---

**(12) PATENT ABRIDGMENT (11) Document No. AU-B-35196/89**  
**(19) AUSTRALIAN PATENT OFFICE (10) Acceptance No. 618356**

---

- (54) Title  
**HEAT SHIELD**
- International Patent Classification(s)  
(51)<sup>4</sup> **F21L 007/00 F21V 007/20**
- (21) Application No. : **35196/89** (22) Application Date : **25.05.89**
- (30) Priority Data
- (31) Number (32) Date (33) Country  
**208266 17.06.88 US UNITED STATES OF AMERICA**
- (43) Publication Date : **21.12.89**
- (44) Publication Date of Accepted Application : **19.12.91**
- (71) Applicant(s)  
**MAG INSTRUMENT, INC.**
- (72) Inventor(s)  
**ANTHONY MAGLICA; RALPH EMSLEY JOHNSON**
- (74) Attorney or Agent  
**SPRUSON & FERGUSON , GPO Box 3898, SYDNEY NSW 2001**
- (56) Prior Art Documents  
**US 4703401**  
**US 4563730**  
**EP 71585**
- (57) Claim

1. A reflector assembly comprising  
a reflector body made of a first material, for focussing a beam of light out through the lens,  
a heat shield made of a second material  
whereby said heat shield is positioned at a converging end of said reflector body and includes a first portion having a first outer diameter and a first inner diameter and extending into a hole formed in a center region of said converging end of said reflector body, and a second portion having a second outer diameter and a second inner diameter which is equal to said first inner diameter, and which is disposed behind said converging end of said reflector body, and  
wherein said heat shield first portion is tubular and extends into said hole formed in said center region of said converging end of said reflector body and surrounds a longitudinal portion of a glass tube of a light bulb, and wherein said heat shield second portion is annular.

7. A flashlight reflector assembly including  
a substantially parabolic reflector for focussing a beam of light out through the lens and having a first converging end and a second annular end and comprising a high temperature plastic material having a plurality of ribs extending outwardly from a first side of said parabolic reflector and a reflectorized coating on a second side of said parabolic reflector and,

(11) AU-B-35196/89  
(10) 618356

-2-

a hole positioned in the center of said parabolic reflector at said first converging end, a heat shield positioned at said first converging end of said reflector assembly and having a first portion, wherein said first portion is tubular and a second portion wherein said second portion is annular and further wherein said second portion extends radially outward from said hole and matingly engages with said ribs of said parabolic reflector and wherein said first portion extends perpendicularly from a first end of said second portion and extends into said hole in said parabolic reflector.

FORM 10

COMMONWEALTH OF AUSTRALIA

PATENTS ACT 1952

COMPLETE SPECIFICATION

618356

(ORIGINAL)

FOR OFFICE USE:

Class      Int Class

Complete Specification Lodged:  
Accepted:  
Published:

Priority:

Related Art:

Name and Address  
of Applicant:      Mag Instrument, Inc.  
1635 South Sacramento Avenue  
Ontario California 91761  
UNITED STATES OF AMERICA

Address for Service:      Spruson & Ferguson, Patent Attorneys  
Level 33 St Martins Tower, 31 Market Street  
Sydney, New South Wales, 2000, Australia

Complete Specification for the invention entitled:

Heat Shield

The following statement is a full description of this invention, including the best method of performing it known to me/us

ABSTRACT OF THE DISCLOSURE

A flashlight reflector assembly including the substantially parabolic reflector having on one surface a reflectorized material, having a hole through its center as its converging end, and a plurality of support ribs extending from the backside of the reflector wherein a stainless steel heat shield is press fit into the back side of the reflector for protecting the reflector from over temperature conditions by reflecting heat back into the lamp and by conducting heat away from the converging portion of the reflector outward to the plurality of pins located behind the reflector reflecting surface.

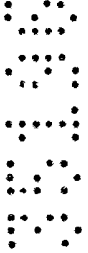

S P E C I F I C A T I O N

HEAT SHIELD

BACKGROUND OF THE INVENTION

This invention relates to a reflector assembly which protects against over temperature conditions and subsequent distortion of a substantially parabolic reflector in the region near its converging end due to use of high temperature lamps.

Conventional flashlights typically use a vacuum type lamp. These vacuum lamps do not produce temperatures sufficiently high to distort and degrade conventional plastic based reflectors. Also, although high temperature, usually gas-filled, lamps are known in the flashlight and portable lighting industry, it is common to use metal based reflectors with such lamps to thereby avoid the distortion problems which would otherwise be created with use of plastic based reflectors.

OBJECTS OF THE INVENTION

It is an object of the present invention to provide a heat shield for a plastic base reflector.

It is a further object of the present invention to provide a heat shield and heat conducting member for use in conjunction with a flashlight reflector.

It is a further object of the present invention to provide a plastic-bodied reflector which is capable of withstanding the high temperature environments produced by gas-filled, high temperature lamps.

It is a further object of the present invention to

into the lamp of a flashlight and also conducts heat away from a region near a flashlight lamp to prevent distortion of a reflector surface near the lamp.

SUMMARY OF THE INVENTION

The present invention is directed to a reflector assembly for use with lighting products, such as flashlights. The reflector assembly includes a reflector with a reflectorized surface and a heat shield positioned so as to prevent extreme temperatures from a high temperature lamp causing distortions on the reflectorized surface of the reflector and thereby causing degradation of the reflected light beam. The reflector is generally a parabolic type reflector having, preferably, a plastic type body with an aluminum reflectorized surface, although the reflector may be made of other materials. The heat shield of the present invention used in conjunction with the reflector is some other material which will reflect light and heat back into the lamp ~~which~~ and will also conduct heat from the lamp to remote regions of the reflector or to a non-reflector heat sink so as to prevent a path of heat from the lamp to areas of the reflector which could be damaged sufficient to cause distortions in the reflectorized surface.

The heat shield includes an annular disc of a predetermined thickness having a tubular portion extending perpendicular from the annular disc at its central hole and extending to a predetermined distance sufficient to provide substantial reflection of light and heat into the lamp as well as conduction of heat away from the lamp to prevent high temperature conditions in the body of the reflector near its reflecting surface. The heat shield is positioned at the converging end of the reflector and is also sized and positioned within the

reflector so as to create air gaps between the bulb and the heat shield, between the heat shield and the reflector body in a direction radially outward from the filament of the lamp bulb and between the heat shield and the reflector body extending radially outward from the lower edge of the tubular portion where it merges with the annular disc portion of the heat shield and above the disc portion. The back side of the reflector is provided with ~~insert, or~~ recess areas sufficient to provide the air gaps between the heat shield and the reflector and inserts or recesses to provide for a tight fit at distal regions of the disc portion of the heat shield. Such regions of the reflector may be formed integral with the body and form a plurality of ribs which extend backward and away from the reflectorized surface of the reflector to not only anchor the heat shield, but also to act as heat sinks.

BRIEF DESCRIPTION OF THE DRAWINGS

Figure 1 is an exploded, rear perspective view of a preferred reflector assembly of the present invention.

Figure 2 is a cross-sectional view of the Figure 1 reflector assembly, shown with a lamp in a position as may be found during operation of a flashlight having a reflector assembly as shown in Figure 1.

Figure 3 is a cross-sectional view of the Figure 1 reflector assembly without its accompanying heat shield.

Figure 4 is a cross-sectional view of a heat shield of the Figure 1 reflector assembly, without the reflector.

Figure 5 is a rear view of the Figure 1 reflector without the accompanying heat shield.

Figure 6 is a cross-sectional view of a first alternate embodiment of a reflector assembly of the present invention.

Figure 7 is a cross-sectional view of a second alternate embodiment of a reflector assembly of the present invention.

5 Figure 8 is a cross-sectional view of a third alternate embodiment of a reflector assembly of the present invention.

Figure 9 is a cross-sectional view of a fourth alternate embodiment of the reflector assembly of the present invention.

10 Figure 10 is a cross-sectional view of a fifth alternate embodiment of a reflector assembly of the present invention.

DETAILED DESCRIPTION OF PREFERRED EMBODIMENTS

By reference to Figures 1-10 preferred embodiments of the reflector assembly of the present invention will be described.

15 Referring to Figure 1 an exploded, rear perspective view of a preferred reflector assembly of the present invention is shown generally at 1. The reflector assembly includes a reflector body 2 having ribs 9, and heat shield 3 with a hole 11 in its center for insertion of a lamp.

20 The reflector assembly 1 of the present invention may be used in conjunction with virtually any lighting product, but is preferably for use with flashlights of the type disclosed in Australian Patent Serial No. 609198 (application No. 23796/88) or in U.S. Patent No. 4,577,263, U.S. Patent No. 4,656,565, and U.S. Patent No. 4,658,336. Also, the reflector assembly of the present invention is most preferably used in those flashlights having relatively high-intensity lamps which produce



correspondingly high temperatures at the filament and adjacent to the lamp near the flashlight reflector. When such high temperature lamps, usually those filled with a gas such as xenon are used, sufficiently high temperatures adjacent the lamp are produced to cause distortions in the reflector surface and degradation of reflected light from reflectorized surfaces of conventional plastic body reflectors. Although it is known to use steel-body reflectors, such reflectors are relatively expensive and difficult to manufacture. Accordingly it is an object of the present invention to provide a plastic-bodied reflector which is capable of withstanding the high temperature environments produced by gas-filled, high temperature lamps.

Referring to Figure 2, which is a cross-sectional view of the Figure 1 reflector assembly, including a typical flashlight lamp 4 placed in position as may be found during normal operation of a flashlight and which will produce the most severe temperatures at the converging region of the reflector body. The lamp 4 is shown having glass envelope 5, filament 6, and pins 7 and 8 for providing a source of light. The lamp 4 is shown as a bare base, bi-pin type lamp. The present invention may be used in conjunction with other types of lamps. Typically, the bulb 5 is filled with a gas such as xenon which may or may not be under pressure. As is well known, such gas-filled lamps produce a relatively bright light, with correspondingly relatively high temperatures at the filament and adjacent to the bulb 5, as shown at 57. A reflector 2 is shown with a reflectorized surface 16 on its concave surface for reflecting light emitted from filament 6 and for focusing the beam of light out through a lens, not shown. Reflectorized material 16 may be placed on the reflector body 2 by conventional means. Reflector

body 2 is shown with a plurality of ~~support~~ ribs 9, which are also shown in Figures 1-3 and 5.

The shield 3 of the present invention includes a disc portion 3A having near its central hole a tubular portion 3B of the disc body extending perpendicularly to form a short tubular or cylindrical portion 3B. The shield 3 may be press fit into the main body of the reflector 2 along and within recessed portions at edge 14, the recessed portions are radially inward of and adjacent to the outer edge of ribs 9.

As also shown in Figure 2, a small air gap 13 exists between the outer periphery of bulb 5 and the inner periphery of tube portion 3B of shield 3. Also, as shown in Figure 2 another small air gap 12 is established between the outer periphery of the tube portion 3B of shield 3 and the inner periphery of the hole 10 which is in the center of reflector 2 adjacent to the tube portion 3B. Extending radially outward from the lower part of the tube portion 3B to a predetermined distance along the disc portion 3A of the back of the disc 3 a third air gap 17 is established between the upper surface of the disc portion 3A and the reflector 2 adjacent hole 10.

The reflector body 2 is preferably made of a high temperature plastic material such as, for example, Ultem<sup>TM</sup>. Other known, high temperature plastics may be used as the reflector body material. The reflector body material performs the functions maintaining a good, smooth surface for the reflector material 16 during extended operation with high temperature lamps. The reflector material 2 also function to provide a smooth surface, that is, a surface having relatively few or no flow lines or seams and to, provide for excellent optical properties when coated with reflectorized material 16.

must exhibit minimal shrinkage, that is no more than about 1% mold shrinkage when solidifying from liquid to solid state. In order to minimize potential optical distortions when coated with reflectorized material 16, it is preferred that the material used for the reflector body have a heat deflection temperature of at least about 445°F, although materials having deflection temperatures as low as 385°F are acceptable for the purposes of the present invention. The plastic body 2 of the reflector may be made with conventional injection molding techniques.

In the absence of a means to remove excess heat, such as the reflector-heat shield assembly of the present invention, high temperature lamps, such as gas-filled lamps ~~in~~ may cause distortion on the reflectorized surface 16 of the reflector body. Typically, the reflectorized surface is a thin coating of aluminum which may become distorted where excess heat has caused distortions and/or bubble formation within the body of the reflector 2. Such distortions result in degradation of the reflected beam of light through the lens.

The shield 3 is preferably made of a material which provides good reflection of light back into the bulb and also provides good conduction of heat from the tube portion 3B of the shield 3 to the disc portion 3A and then to the ribs 9 of the reflector body 2. Stainless steel, type 303, 304, or 316 is preferred. Other materials which function to provide acceptable reflection and conduction properties may be used in the present invention.

The stainless steel heat shield 3 may be made by conventional machining or stamping processes. The heat shield 3 may also be made with burrs at the ends of the disc portion 3A, to prevent falling out, or rotation, <sup>of</sup> the shield 3 relative to the

As shown in Figure 2, the filament 6 is positioned adjacent to and radially inward of tube portion 3B of the heat shield 3. In this position of maximum potential heat transfer to the reflector, and assuming no heat shield were in place, the temperatures reached from use of a gas-filled lamp such as a xenon lamp, could, in many instances, create temperatures high enough to cause melting of plastic reflector material and consequent distortion of the optical surface 16 on the reflector body 2 with consequent degradation in the optical characteristics of the beam emitted from the flashlight.

It has been found that with a typical gas-filled lamp 6 that a temperature at filament 6 of approximately 435°F may be achieved, depending upon the voltage, gas-fill and current used in the particular lamp application. Generally, it is desirable in flashlight applications to use as much power from the battery as available to give maximum brightness, or light, consistent with a predetermined useful battery expected lifetime. In the case of a three cell, AA sized flashlight wherein the three cells are oriented in series to provide approximately 4.5 volts of electric potential, it has been found that a lamp drawing approximately 400 milliamperes of current will result in a battery life of about 3 hours or more. With such design criteria, it has been determined that the equilibrium temperature of the bulb glass at 57 is at about 460°F. With an equilibrium temperature maximum of about 460°F at the filament, it is desired to achieve a corresponding equilibrium temperature in the reflector body which is low enough to prevent distortion and/or degradation of the reflector material, and in turn to prevent degradation of reflector performance.

It has been determined that when the bulb glass

temperature of the tube portion 3B of the heat shield is about 375°F. As heat is conducted from the tube portion 3B through the disc portion 3A of the heat shield 3, the temperature at the outer radial periphery of the disc portion 3A of the shield 3 where it contacts the reflector 2, at 14 is about 310°F. Also, at the inner periphery of the disc portion 3A of the heat shield 3, shown at 18, the temperature is approximately 350°F under these conditions. One design criterion is to insure that at region or edge 14 temperatures do not reach a high enough temperature to cause degradation of the plastic reflector body 2. If this criterion is met at 10 edge 14, then it can be safely assumed that no degradation of the reflectorized surface 16 will result due to generation of heat at the surface of the bulb glass, as shown at 57.

It is noted that the air gap 12 shown radially outward of tube portion 3B of heat shield 3 and the air gap 17 located adjacent a 15 predetermined radius along the main portion 3A of the heat shield 3 functions as an insulator to prevent high temperature being reached in the corresponding adjacent regions of the plastic reflector body 2. Such air gaps permit only radiation type heat transfer as opposed to conduction heat transfer which would occur if the plastic reflector 20 material touched the heat shield material in these regions. It is also noted that the stainless steel heat shield material is a relatively poor emitter, a poor electric conductor but is a relatively good light and heat reflector.

Although the heat shield of the present invention is intended 25 primarily for use with a plastic body reflector the heat shield may also be used in conjunction with metal reflectors, or reflectors of other material where it is desired to have an additional means to remove heat from the region of the reflector near the lamp.



STA/1665w

It is noted that although an air gap 13 is shown between the heat shield 3 and the lamp 4, flashlight lamps occasionally are inserted in a crooked fashion, or the pins may become bent during use and therefore the bulb may be tilted to one side and touch the heat shield 3. Such touching is acceptable, although, it is preferred that a small air gap exist between lamp 4 and the heat shield 3. What is more important is that air gaps 12 and 17 be maintained between the heat shield 3 and the reflector body 2.

As shown in the Figure 1 preferred embodiment the disc portion 3A of the heat shield 3 extends out to and physically <sup>rearward surfaces</sup> contacts the ~~bottom~~ of the ribs 9 of the plastic reflector 2. In this configuration the ribs 9 act not only as anchors, or physical supports for the metal shield and the reflector, but also function as heat sinks for heat transferred from the lamp filament 6 through the heat shield 3. Although it is preferred to have the heat shield 3 configured such that heat is transferred to the ribs 9, acceptable reflector assemblies may be constructed which do not provide for heat transfer to ribs but rather are of sufficient means to act as the heat sink, or will transfer heat to some other remote component which acts as a heat sink.

Although the reflector assembly of the present invention may be used for virtually any flashlight or portable light application where it <sup>is</sup> desired to remove excess heat from near the base of the reflector, the preferred embodiment is intended for use with a three cell, AA sized flashlight similar to that disclosed in co-pending application Serial No. 111,538. In such an application the diameter of the hole 11 in the heat shield 3 is approximately 0.147 inches. The diameter of the heat

the disc portion 3A of the heat shield 3 is approximately 0.02 inches, with the tube portion 3B of the heat shield 3 extending perpendicularly from the main disc body portion an additional 0.070 inches. As shown in Figure 3, the first, or greater radius insert from the center out to edge 14 at the bottom of the reflector body has an diameter of approximately 0.600 inches to provide a tight, press fit of the heat shield 3 into the lower region of the reflector body 2. The smaller radius insert cavity which defines air gap 17, with edge 15, as shown in Figure 3, has a diameter of approximately 0.300 inches. The depth of the insert shown at 14 is approximately 0.025 inches with a depth of the second insert, as shown at 15, of approximately 0.010 inches. The diameter of the hole 10 through the reflector body 2, as shown in Figure 1, is approximately 0.187 inches.

Referring to Figures 6-10, several alternate embodiments of the heat shields are shown configured within the reflector 2. In general, the heat shield may vary in the dimensions of the diameter of the disc portion 3A, the thickness of the disc portion 3A, and the height, thickness and diameter of the tube portion 3B. For example, it may be seen that in Figure 6, the disc portion 3A has a second cylindrical portion 3C which extends downward from the main disc portion 3A to provide an extra heat sink and mechanical support. Referring to Figure 7, it may be seen that the disc portion 3A is of a smaller diameter than that of the Figure 1 embodiment disc portion 3A, but is of a greater thickness. Referring to Figure 8 it may be seen that the sizing of tube portion 3B of the heat shield is slightly longer than that as shown in the Figure 1 embodiment. Referring to Figure 9 it may be seen that the diameter of the main disc portion 3A is smaller than that of the Figure 1 embodiment, and

embodiment. Referring to Figure 10 it may be seen that the main disc portion 3A is even smaller than that of the Figure 9 embodiment.

The above described embodiments may be constructed with numerous alterations and equivalent features, all of which are intended to be covered by the scope of the present invention. The above disclosed embodiments are not intended to limit the invention but rather to illustrate preferred embodiments within the scope of the present invention, which is defined by the following appended claims.

1  
2  
3  
4  
5  
6  
7  
8  
9  
10

The claims defining the invention are as follows:

1. A reflector assembly comprising  
a reflector body made of a first material, for focussing a beam of  
light out through the lens,

a heat shield made of a second material

whereby said heat shield is positioned at a converging end of said  
reflector body and includes a first portion having a first outer diameter  
and a first inner diameter and extending into a hole formed in a center  
region of said converging end of said reflector body, and a second  
portion having a second outer diameter and a second inner diameter which  
is equal to said first inner diameter, and which is disposed behind said  
converging end of said reflector body, and

wherein said heat shield first portion is tubular and extends into  
said hole formed in said center region of said converging end of said  
reflector body and surrounds a longitudinal portion of a glass tube of a  
light bulb, and wherein said heat shield second portion is annular.

2. The reflector assembly of claim 1 wherein said heat shield  
first portion extending into said hole formed in said center region of  
said converging end of said reflector body is isolated from said  
converging end of said reflector body by a first air gap and said second  
heat shield portion is isolated from said converging end of said  
reflector body by a second air gap formed between said heat shield second  
portion and said converging end of said reflector body orthogonal to said  
first air gap and extending for a predetermined radius outward from said  
first outer diameter of said heat shield first portion.

3. The reflector assembly of any one of claims 1 or 2 wherein  
said reflector body has a substantially parabolic shape.

4. The reflector assembly of any one of claims 1 through 3  
wherein the reflector material is a high temperature plastic.

5. The reflector assembly of any one of claims 1 through 4  
wherein the heat shield is of stainless steel.

6. The reflector assembly of any one of claims 1 through 5  
wherein said reflector body includes a plurality of ribs which extend  
away from a first wall of said reflector body and wherein said second  
portion of said heat shield contacts said plurality of ribs.



STA/1665w

7. A flashlight reflector assembly including

a substantially parabolic reflector for focussing a beam of light out through the lens and having a first converging end and a second annular end and comprising a high temperature plastic material having a plurality of ribs extending outwardly from a first side of said parabolic reflector and a reflectorized coating on a second side of said parabolic reflector and,

a hole positioned in the center of said parabolic reflector at said first converging end, a heat shield positioned at said first converging end of said reflector assembly and having a first portion, wherein said first portion is tubular and a second portion wherein said second portion is annular and further wherein said second portion extends radially outward from said hole and matingly engages with said ribs of said parabolic reflector and wherein said first portion extends perpendicularly from a first end of said second portion and extends into said hole in said parabolic reflector.

8. The reflector assembly of claim 7 wherein said heat shield first portion extending into said hole formed in said center of said converging end of said reflector body is isolated from said converging end of said reflector body by a first air gap and said second heat shield portion is isolated from said converging end of said reflector body by a second air gap formed between said heat shield second portion and said converging end of said reflector body orthogonal to said first air gap and extending for a predetermined radius outward from said first outer diameter of said heat shield first portion.

9. A reflector assembly substantially as described with reference to any one of Figs. 1-5, 6, 7, 8, 9 or 10.

DATED this TWENTY-SEVENTH day of SEPTEMBER 1991

Mag Instrument, Inc.

Patent Attorneys for the Applicant  
SPRUSON & FERGUSON



1/2

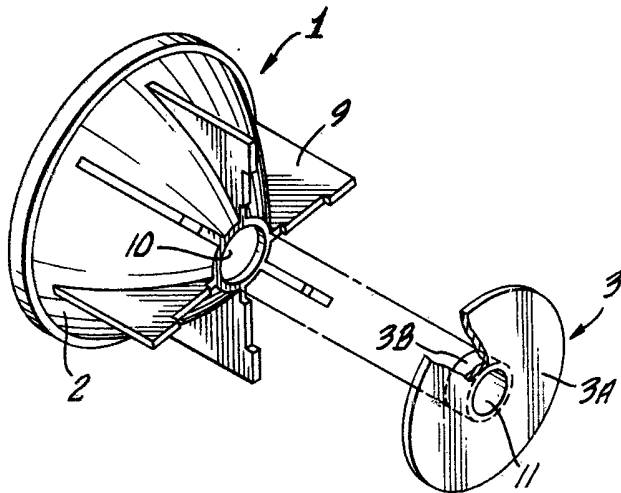

FIG. 1.

FIG. 2.

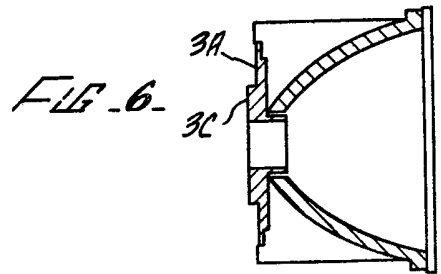
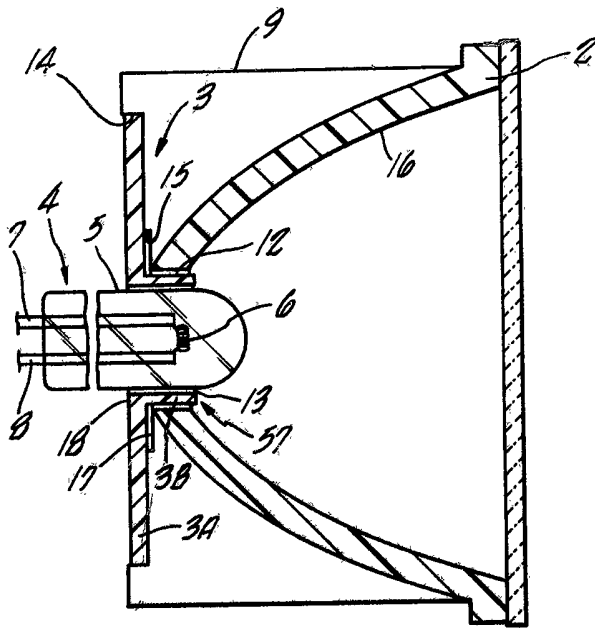

FIG. 6.

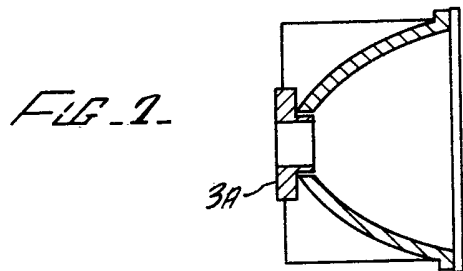

FIG. 7.

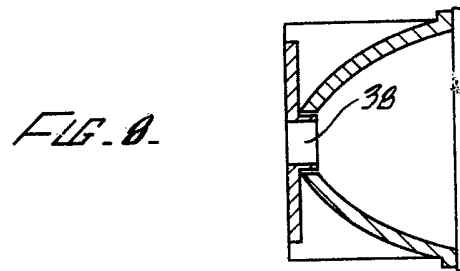

FIG. 8.

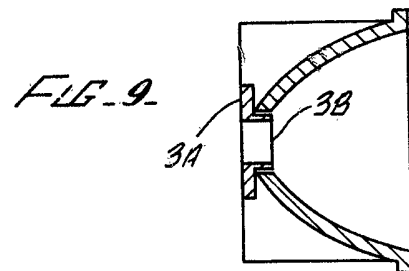

FIG. 9.

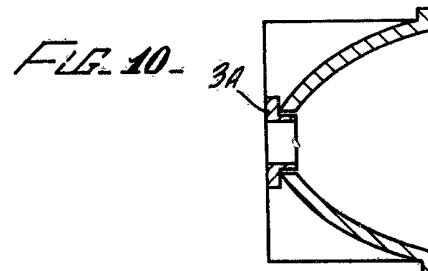

FIG. 10.

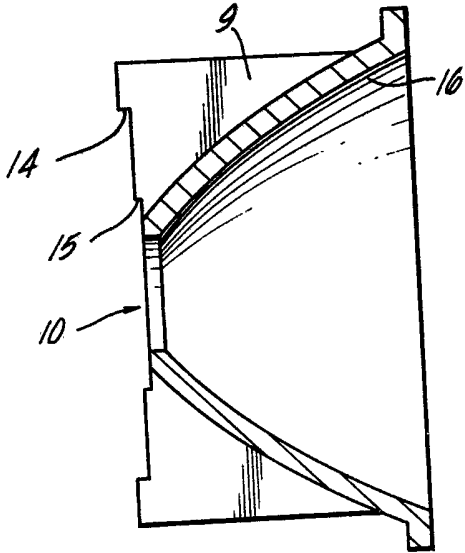

FIG. 3.

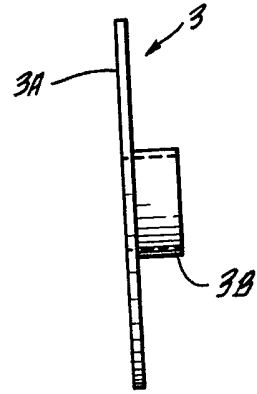

FIG. 4.

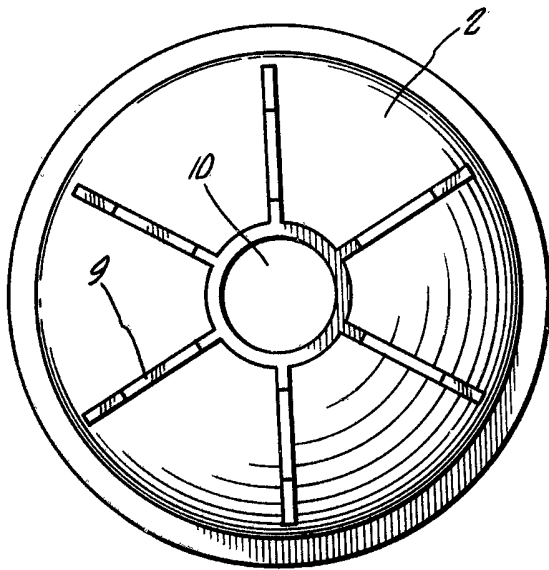

FIG. 5.