

June 11, 1935.

E. K. GLADDING ET AL

2,004,162

BOBBIN TRAVERSE MOTION

Filed Dec. 2, 1931

2 Sheets-Sheet 1

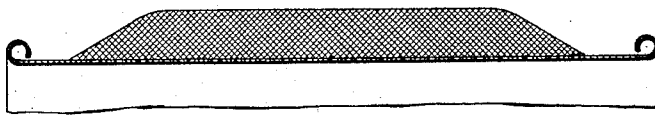
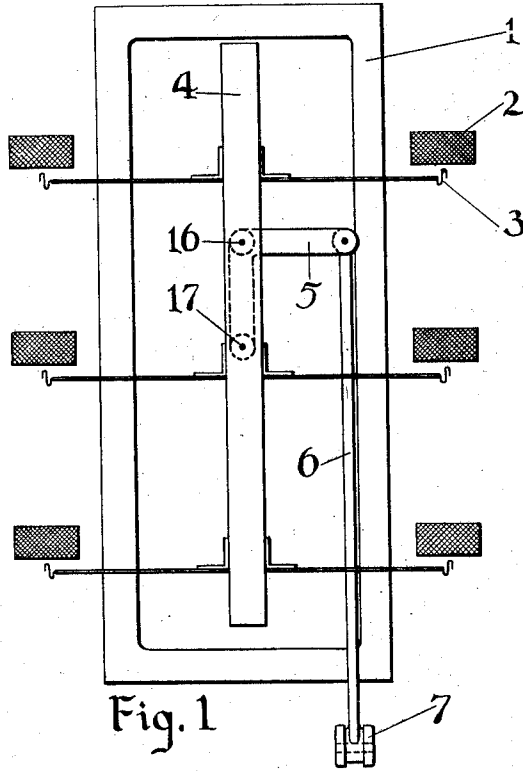

Fig. 5

Inventors

Ernest H. Gladding,
David F. Evans,

By

John Lawrence Seymour

Attorney

June 11, 1935.

E. K. GLADDING ET AL

2,004,162

BOBBIN TRAVERSE MOTION

Filed Dec. 2, 1931

2 Sheets-Sheet 2

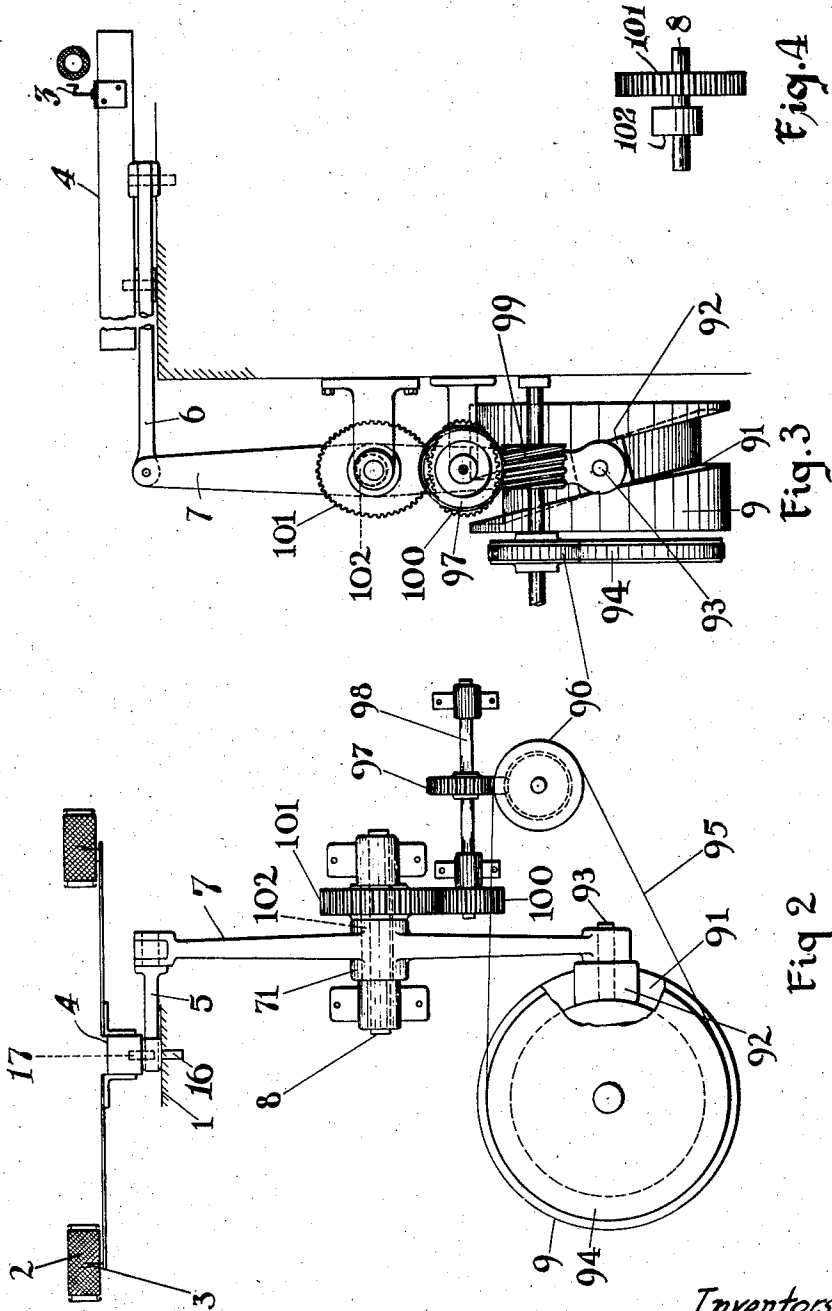

Fig. 4

Fig. 3

Fig. 2

Inventors

Ernest K. Gladding
David F. Evans

By John Lawrence Seymour
Atty.

UNITED STATES PATENT OFFICE

2,004,162

BOBBIN TRAVERSE MOTION

Ernest K. Gladding and David F. Evans, Buffalo,
N. Y., assignors to Du Pont Rayon Company,
New York, N. Y., a corporation of Delaware

Application December 2, 1931, Serial No. 578,432

11 Claims. (Cl. 242-43)

This invention relates to the manufacture of rayon. More particularly the invention relates to means for winding rayon upon a bobbin in the form of a cake having bevelled ends. The invention further relates to the winding of thread upon thread holders.

This invention will be described with particular reference to the manufacture of rayon from viscose although it is to be understood that the invention is not limited thereto.

In the manufacture of rayon, which is the name adopted for practically all types of artificial thread, it is customary to wind the thread upon a perforated or foraminous bobbin in the form of a cake having a center portion of uniform thickness and ends which taper down to a few layers. These bobbins, after winding is complete, are carried to suitable treating apparatus where the cake is subjected to fluid treatment by pressure, vacuum, or centrifugal methods. If the fluid treatment is to be uniform, the thread must be so wound that the fluid which passes through the cake will treat the thread uniformly in all areas. In order to avoid a rush of liquid at the thinly wound ends of the cake a bobbin is advantageously used having imperforate ends which are overlapped by the ends of the cake. It follows from this practice that, if the layers of thread at the ends are too thick or extend too far beyond the holes, the thread is subject to non-uniform treatment or must be treated for an excessively long time. The length of the traverse stroke to adjust the amount by which the cake overlaps the imperforate section of the bobbin can be adjusted with comparative simplicity but methods heretofore in use have failed to produce a cake having ends bevelled in the form of a smooth curve, that is to say that the thread is wound (as in Figure 4) with protuberances and not in the desirable shape shown in Figure 5.

In the winding of a cake having tapered ends a traverse mechanism may be used having a stroke shorter than the desired length of the finished cake and a traverse motion which gradually shifts this stroke from end to end of the bobbin. This is termed a builder motion of constant stroke but shifting origin.

It is an object of this invention to improve the manufacture of rayon. Another object of the invention is to improve the mechanism for the winding of thread. Yet another object of the invention is to produce rayon cakes which are susceptible to uniform treatment. Another object of the invention is to develop a mechanical

motion capable of winding thread into a cake having bevelled ends in the form of a smooth curve.

The objects of this invention are attained by giving the traverse mechanism a constant stroke, by imposing upon this constant stroke a shifting origin, and by imposing upon this shifting origin a motion or change of motion whereby desired results are accomplished.

In the drawings Figure 1 is a plan view of a spinning machine. Figure 2 is a vertical end view of Figure 1, omitting certain immaterial details, showing the mechanical movement of the traversing mechanism. Figure 3 is a side view of the mechanism shown in Figure 2. Figure 4 is a diagrammatic view of the eccentric. Figure 5 is a view showing the improved cake produced by the practice of our invention.

In the drawings 1 indicates the frame of a rayon spinning machine; 2 are bobbins upon which thread is wound; 3 are guides for directing the thread upon the surface of the bobbin; 4 is a traversing bar to which guides 3 are attached; 5 is a bell crank; 16 is a pivot in frame 1 about which the bell crank swings; 17 is a pivot in traversing bar 4 to which the end of the bell crank is attached and whereby the said bar is traversed; 6 is a drag link for imparting motion to the bell crank; 7 is a lever for imparting reciprocating motion to the drag link; 11 is a hub between the ends of the lever; 8 is a shaft upon which the lever is pivoted; 9 is a wheel; 91 is a cam circumscribing the face of wheel 9; 92 is a block travelling in cam groove 91; 93 is a pivot pin connecting the lower end of lever 7 with block 92.

By the mechanism above described the bar 4 is given a uniform reciprocating motion transversely of the frame of the machine and if operated without other mechanism would build up a cake having square ends and approximately uniform thickness. In order to produce the bevelled ends, the mechanism hereinafter described is used.

94 is a wheel attached to cam wheel 91; 95 is a driving belt or chain; 96 is a wheel driven by belt 95 from wheel 94; 97 is a gear keyed to shaft 98; 99 is a worm driven by wheel 96 and driving gear 97; 100 is an elliptical gear mounted on shaft 98; 101 is an elliptical gear meshing with gear 100 and keyed to shaft 8; 102 is an eccentric keyed to shaft 8. Upon this eccentric is mounted the hub 11 of lever 7.

By means of this mechanism a primary reciprocating motion is given to the traversing bar

by the cam wheel 9. Upon this primary reciprocating motion the eccentric imposes a difference in origin and by this imposition causes the traversing bar and the guides to travel gradually from end to end of the bobbins thus building up a cake having a comparatively thick center portion with bevelled ends.

Usually the gears 100 and 101 driving the eccentric are ordinary circular gears and give to the eccentric a uniform, angular velocity. The resulting, secondary motion of the hub 71 and the traverse bar is, therefore, of harmonic type, slow at the ends and fast in the center. This causes an accumulation of thread at the ends of the secondary motion and gives a cake having bevelled but sinuous ends.

If, however, the gears 100 and 101 are elliptical or other satisfactory shape, with their axes set so as to offset the harmonic effect of the eccentric, the result is a uniform, secondary motion of the hub 71 and the traverse bar, with no accumulation of thread at the ends of the stroke. The resultant cake has ends of substantially uniformly increasing cross section.

It is not necessary to use purely elliptical gears such as shown in Figure 3 but other gears of irregular conformation may be used as for instance three-cornered gears in proper sizes. The principle of the invention may be deduced from this that the cam wheel and eccentric hub alone will produce a curve having a more or less definite mathematical expression. The elliptical gears will also produce a curve having a more or less definite mathematical expression. By selecting the combination so that the two curves are of the same magnitude but out of phase, a substantially smooth bevelled end will be secured. For instance, if the wheel and eccentric produce a motion expressible by a sine curve, gears should be used which also give motion expressible by a sine curve of the same or similar magnitude, but in use should be placed approximately 180° out of phase. From this it will be apparent that by altering the shape of the gears compensation of the motion can be complete or only partial but that the degree of compensation lies within the province of the engineer.

An advantage of our invention is the winding of rayon in cakes which are susceptible to more uniform washing and which have superior winding characteristics. Another advantage of our invention is the formation of a cake of thread the ends of which do not wash down during fluid treatment. Other advantages of the invention will be apparent.

As many apparently widely different embodiments of this invention may be made without departing from the spirit and scope thereof, it is to be understood that we do not limit ourselves to the specific embodiments thereof except as defined in the appended claims.

We claim:

1. In a winding machine a rotating bobbin, a guide, reciprocating means for traversing the guide before the bobbin in a path less than the length thereof, eccentric means for shifting the path of the reciprocating means along the bobbin, and a non-circular gear operatively connected to the said means whereby the speed of the guide at the ends of its stroke will be regulated to produce a thread cake having substantially uniformly decreasing bevelled ends.

2. In the manufacture of rayon a rotating bobbin, a guide, means for traversing the guide comprising a lever and means for reciprocating it,

means for shifting the travel of the guide comprising an eccentric operatively connected to the lever, and means for controlling the motion of the guide comprising an elliptical gear operatively connected to the said eccentric.

3. In the manufacture of rayon a rotating bobbin, a guide, means for traversing the guide comprising a lever and a cam wheel, means for shifting the travel of the guide comprising an eccentric operatively connected to the lever and means for controlling the motion of the guide comprising an elliptical gear operatively connected to the said eccentric.

4. In a winding machine a bobbin, means for laying thread thereon comprising a guide, means for imparting to the guide a builder motion of constant stroke comprising a cam-operated lever, means for shifting the point of origin of the stroke of the guide comprising an eccentric pivot upon which the lever is mounted, and means for so controlling the motion of the guide that the cake formed on the bobbin will have bevelled ends of substantially uniformly increasing thickness comprising elliptical gears for rotating the eccentric, the shape and size of the gears and their speed of rotation being such that the speed of the guide will be substantially constant centrally of the bobbin and varying at the ends thereof.

5. In a winding machine, winding means, means for laying thread thereon comprising a guide, means for imparting to the guide a builder motion of constant stroke comprising a cam-operated lever, means for shifting the point of origin of the stroke of the guide comprising an eccentric pivot upon which the lever is mounted, and means for so controlling the motion of the guide that the cake formed on the winding means will have bevelled ends of substantially uniformly increasing thickness comprising non-circular gears for rotating the eccentric, the shape and size of the gears and their speed of rotation being such that the speed of the guide will be substantially constant at the center of the winding means and correctly varied at the ends thereof.

6. In a winding machine, winding means, a guide, means for imparting to the guide a stroke of uniform length comprising a lever, means for shifting the point of origin of the stroke of the guide comprising an eccentric pivot upon which the lever is mounted, and means for so controlling the motion of the guide that the cake formed on the winding means will have bevelled ends of substantially uniformly increasing thickness comprising non-circular gears for rotating the eccentric, the shape and size of the gears and their speed of rotation being such that the speed of the guide will be substantially constant centrally of the winding means and correctly varied at the ends thereof.

7. In a winding machine, winding means, a guide, means for imparting to the guide a stroke of uniform length and shifting origin comprising a reciprocable lever mounted on a rotatable eccentric, and means for so controlling the motion of the guide that the cake formed on the winding means will have bevelled ends of substantially uniformly increasing thickness comprising elliptical gears for rotating the eccentric, the shape and size of the gears and their speed of rotation being such that the speed of the guide will be substantially constant centrally of the winding means and correctly varied at the ends thereof.

8. In a winding machine, winding means, a reciprocable guide, eccentric means operatively connected thereto for shifting the point of origin of the stroke of the guide, and means for so controlling the motion of the guide that the cake formed on the winding means will have bevelled ends of substantially uniformly increasing thickness comprising non-circular gears for rotating the eccentric means, the shape and size of the gears and their speed of rotation being such that the speed of the guide will be substantially constant centrally of the winding means and correctly varied at the ends thereof.

9. In a winding machine, winding means, a guide, means for reciprocating the guide comprising a lever, and means for shifting the point of origin of the stroke of the guide, and for so varying the motion of the guide that the cake formed on the winding means will have bevelled ends of substantially uniformly increasing thickness comprising an eccentric fulcrum for the lever, and means for rotating the eccentric fulcrum with a motion which will impart to the guide a speed substantially constant centrally of the winding means and varied at the ends thereof.

10. In a winding machine, winding means, a guide, a lever for reciprocating the guide, eccentric means operatively connected to the lever for shifting the point of origin of the stroke of the guide, and means for improving the constancy in the rate of the change of the origin of the stroke comprising gears for rotating the eccentric at a variable angular velocity.

11. In a winding machine a rotating bobbin, a guide whereby thread may be transferred to the surface of the bobbin, means for traversing the guide along the face of the bobbin comprising a reciprocable lever operatively connected to the guide and means to reciprocate the lever, an eccentric operatively connected to the fulcrum of the lever whereby its position may be changed and whereby the path of the guide may be shifted along the face of the bobbin, and means for further modifying the motion of the lever and of the guide comprising an elliptical gear operatively connected to the said eccentric.

ERNEST K. GLADDING.
DAVID F. EVANS.