

CORRECTED VERSION

(19) World Intellectual Property Organization
International Bureau



(10) International Publication Number
WO 2012/108773 A9

(43) International Publication Date
16 August 2012 (16.08.2012)

- (51) International Patent Classification:
A63C 10/24 (2012.01)
- (21) International Application Number:
PCT/NO2012/000012
- (22) International Filing Date:
26 January 2012 (26.01.2012)
- (25) Filing Language:
Norwegian
- (26) Publication Language:
English
- (30) Priority Data:
20110226 8 February 2011 (08.02.2011) NO
- (71) Applicant (for all designated States except US): **HITURN AS** [NO/NO]; Sagvollvn. 1, N-2830 Raufoss (NO).
- (72) Inventors; and
(75) Inventors/Applicants (for US only): **KARLSEN, Jørgen** [NO/NO]; Helmerveien 5, N-1363 Høvik (NO). **DUSSELDORP, Dennis** [NL/NL]; Relweg 9, NL-1949 EB Wijk aan Zee (NL). **KIEBERT, Daniel** [NL/NL]; Alberdingk Thijmstraat 1 2h, NL-1054 AH Amsterdam (NL).
- (74) Agent: **ONSAGERS AS**; P.O. Box 6963, St. Olavs Plass, N-0130 Oslo (NO).

- (81) Designated States (unless otherwise indicated, for every kind of national protection available): AE, AG, AL, AM, AO, AT, AU, AZ, BA, BB, BG, BH, BR, BW, BY, BZ, CA, CH, CL, CN, CO, CR, CU, CZ, DE, DK, DM, DO, DZ, EC, EE, EG, ES, FI, GB, GD, GE, GH, GM, GT, HN, HR, HU, ID, IL, IN, IS, JP, KE, KG, KM, KN, KP, KR, KZ, LA, LC, LK, LR, LS, LT, LU, LY, MA, MD, ME, MG, MK, MN, MW, MX, MY, MZ, NA, NG, NI, NO, NZ, OM, PE, PG, PH, PL, PT, QA, RO, RS, RU, RW, SC, SD, SE, SG, SK, SL, SM, ST, SV, SY, TH, TJ, TM, TN, TR, TT, TZ, UA, UG, US, UZ, VC, VN, ZA, ZM, ZW.
- (84) Designated States (unless otherwise indicated, for every kind of regional protection available): ARIPO (BW, GH, GM, KE, LR, LS, MW, MZ, NA, RW, SD, SL, SZ, TZ, UG, ZM, ZW), Eurasian (AM, AZ, BY, KG, KZ, MD, RU, TJ, TM), European (AL, AT, BE, BG, CH, CY, CZ, DE, DK, EE, ES, FI, FR, GB, GR, HR, HU, IE, IS, IT, LT, LU, LV, MC, MK, MT, NL, NO, PL, PT, RO, RS, SE, SI, SK, SM, TR), OAPI (BF, BJ, CF, CG, CI, CM, GA, GN, GQ, GW, ML, MR, NE, SN, TD, TG).

Published: — with international search report (Art. 21(3))

[Continued on next page]

(54) Title: REPLACEABLE CALF SUPPORT (HIGHBACK)

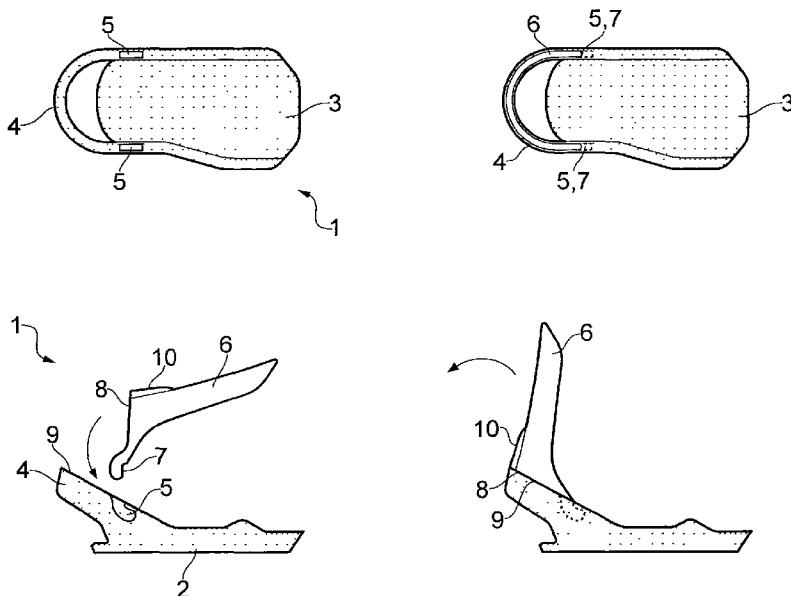

FIG. 1

(57) Abstract: The present invention is based on known types of bindings, where it is provided a binding (1) which can be used without a detachable calf support (6) while retaining the ability of the binding (1) to position the boot correctly in the binding (1). The fundamental principle is that one makes a detachable calf support (6) which can easily be removed and adjusted, whereupon the binding (1) will still be able to position the boot correctly in the binding (1) without being adjusted forwards or backwards in any direction on the snowboard. The device preferably permits the detachable calf support (6) to be removed and replaced again without the use of tools. The invention also offers the opportunity of using different intermediate types of calf support (6).

WO 2012/108773 A9

- (88) Date of publication of the international search report:** 15 November 2012
- (15) Information about Correction:** see Notice of 17 January 2013
- (48) Date of publication of this corrected version:** 17 January 2013

REPLACEABLE CALF SUPPORT (HIGHBACK)

The invention relates to bindings for mounting on a snowboard, where the bindings come in pairs and can be attached to the snowboard's attachment points. More specifically the present invention relates to bindings for snowboards which can easily
5 be adapted to suit the snowboarder's equipment and riding style.

Snowboarders will have different wishes on how the snowboard's binding(s) are to be adapted in order to provide the best riding experience seen in relation to that each snowboarder has his own special riding style. In addition, the bindings of the snowboard must be able to be adapted to the snowboarder's shoe size, the design of
10 the shoe etc.

Ordinary bindings for snowboards are provided with a loop behind the heel, referred to here as a heel cup, where in this loop or in connection therewith an additional support is attached, a so-called calf support or highback, where the calf support extends a certain distance upwards behind the snowboarder's calf, in order to improve
15 the transfer of force from the snowboarder's calf to the snowboard when the snowboard is edged on the heel side. A heel cup with calf support mounted on the inside of the heel cup then together form the space or the arrangement which keep the snowboarder's boot/boots in the correct position in the binding. Forces or loads which arise during a snowboard ride can be quite substantial, thereby requiring a
20 fairly robust construction for both binding and calf support.

Almost all types of bindings allow for a certain regulation or adjustment of the calf support. Most common the calf support will comprise an adjustment device on its backside, such that the calf support can be angled relative to the binding's heel cup. The calf support will then be rotatable around its attachment points with the binding, where the attachment points of the calf support are arranged in an area near the
25 snowboarder's ankle area. In this way the binding can be adapted to suit the snowboarder's riding style and/or skill, in addition to which the calf support will be rotatably mounted, thus enabling it to be folded down against the snowboard's binding, thereby providing a more compact snowboard during transport and/or storage.

A commonly used standard for bindings employs a round plate which fixes the binding to the snowboard. This plate is conical and provided in the form of a gear-wheel, thereby enabling the binding to be adjusted to the desired angle relative to the snowboard's longitudinal direction and locked at this angle when the plate is
30 screwed on. There are also other newer methods for attaching bindings. The binding according to the present invention does not require any special kind of device for fastening it to the snowboard.
35

Furthermore, the binding is made with fastening straps over the boots, which is normal for modern bindings, usually a fastening strap over the instep and one over

the toes, but here too there is no special requirement for further attachment of the boot for the binding according to the present invention, as long as it is sufficiently strong.

As an example of the prior art it shall be referred to US 2007/0114763 A1, US
5 2007/0158929 A1 and US 2008/0258434 A1, where various bindings for snowboards are described. The bindings comprise a receiver part which is mounted on the snowboard and a locking part which is connected to the receiver part, where the locking part is used for securing or releasing the snowboard rider's boot with respect to the binding. The receiver part also comprises a calf support which is adjustable and/or rotatable, thereby enabling adjustment of the binding to be performed or
10 securing or releasing of the snowboarder's boot to be facilitated.

The above-cited publications describe different solutions where a calf support forms a part of the actual binding and is therefore not intended to be removed from the binding's receiver part. This means that the binding can only be used for a specific
15 type of snowboarding, with the result that the binding has to be replaced when performing another type of snowboarding.

It is an object of the present invention to provide a binding for a snowboard which permits replacement of the binding's calf support, thereby enabling the snowboard to be used for several types of snowboarding (with and without calf support), a different calf support (short, medium or long), etc., where the binding requires minimal or no adjustments after removal of the calf support. This is achieved by means
20 of a snowboard binding as specified in the independent patent claim. Further embodiments of the present invention are indicated in the dependent patent claims.

It is a further object of the present invention to provide a binding for a snowboard
25 which allow for adjustment or adaptation of the binding to the snowboarder's riding style and equipment.

A new trend has now appeared where snowboarding is skating-oriented, and it is more interesting to have a lower binding. The present invention is based on the known type of snowboard binding, but where the snowboard binding according to
30 the present invention is designed in such a manner that the binding can also be employed without the calf support, while still retaining the ability of the binding to position the boot correctly in the binding without the use of the calf support. The main principle is that a calf support is provided which can easily be removed, and where the binding should still be able to position the boot correctly in the binding without
35 further adaptation (adjustment forwards or backwards on the snowboard). The calf support should preferably be able to be removed and replaced in again without the use of tools.

The present invention relates to a binding for a snowboard, where the binding is attached to the snowboard by means of one or more devices, where the binding comprises a receiver part which is mounted to the snowboard and at least one locking part which is connected to the receiver part, thereby enabling a snowboarder's boot to be attached to the binding, where the binding is designed to be able to be used both with and without a calf support, where the binding has a simple device for inserting of the calf support, with the result that the calf support is easy to remove from and be attached to the binding, where the binding furthermore will have approximately the same fit and position for the boot with and without the use of the calf support, so that the binding will still position the snowboarder's boot correctly in the binding without adjusting its position on the snowboard. In addition, the binding comprises adjusting devices in order to be able to adjust the angle the calf support forms with the binding (so-called forward lean).

An embodiment of the binding according to the present invention provides a binding which, after removal of the calf support, still locks the boots approximately in the same position as when the calf support was inserted. By means of various attachment devices, the calf support will then be connected to the binding's heel cup, in the actual heel cup, in a sufficiently secure manner, while simultaneously retaining enough "filling" in the heel cup for the snowboarder's boot to be held in approximately the same position when the calf support is removed. The binding according to this embodiment will then comprise a detachable calf support, where there will be no need to insert a device for filling the "gap" in the heel cup after the detachable calf support has been removed, for example when riding without calf support. The binding's heel cup will then be so strong and thick that the heel cup will be provided with a number of attachment devices in the form of openings and/or recesses in its material, to enable it to be employed for attachment and support of the detachable calf support. The detachable calf support will then be provided in a similar manner with attachment devices matching the attachment devices provided in the heel cup.

The binding according to the present invention may therefore be envisaged provided with many different types of attachment devices, but the attachment devices should be designed in such a manner that they still permit the detachable calf support to be rotated forwards, after having been attached to the heel cup. This can be achieved either by the detachable calf support being attached to the heel cup about two rotational points, which rotational points also form the calf supports attachment devices, where each rotational point is arranged on each side of the boot in an area round the snowboarder's ankle, when the snowboarder's boots are connected to the bindings, such that the detachable calf support rotates about these two rotational points, or by letting the heel cup to form the calf support's rotational point, whereby the attachment device's then will be used as adjusting devices for the calf support.

Another embodiment of the binding according to the present invention provides a binding, where, when it is attached to the heel cup, a detachable calf support is arranged on the inside of the binding's heel cup, and on removal of the detachable calf support a "gap" is left between the inside of the heel cup and the heel of the boot, with the result that the boot is wrongly positioned in the binding (the boot will be able to be moved backwards and forwards in the binding) unless a replacement for the calf support is inserted internally in the heel cup. A replacement (insert), which fills the gap between the heel cup and the heel of the boot after the detachable calf support has been removed, will then be able to be connected to the binding's heel cup by means of the same fastening devices which are used for connecting the detachable calf support to the binding, with the result that the replacement provides a correct positioning of the boot in the binding.

The calf supports may then be designed in different ways, where, for example, the calf support may be of a longer or shorter length, designed to be connected in the actual heel cup in the binding, on the inside or the outside of the heel cup, with different attachment devices etc.

The attachment devices which are provided in the heel cup, where in some embodiments of the present invention the attachment devices will also form the rotational point for the detachable calf support, are mounted on the side of the heel cup in an area round the snowboarder's ankle when the boot is connected to the binding. According to the present invention the attachment devices may be mounted internally, externally or also on the top of the heel cup.

For the embodiment where the attachment devices (and/or the rotational point) are mounted on the top of the heel cup, when the detachable calf support is removed, it will be important for the heel cup to be designed with sufficient thickness to keep the boot in the same place in the binding as the boot assumes when the detachable calf support is connected to the heel cup.

In order to achieve the above, the heel cup must completely or partially fill the "gap" between it and the boot, either completely or piecemeal round the heel. Snowboard boots are usually so hard that they can cope with substantially reduced support for keeping them in place, as long as they have certain surfaces to abut or rest against at certain intervals. We should mention, however, that snowboarders travel in lifts with only one boot in the binding, so that the detachable calf support has to be well secured, and it may therefore be expedient to include locking mechanisms which prevent the detachable calf support from falling off.

For the embodiment where the attachment devices (and/or the rotational point) are mounted on the inside of the heel cup, a different principle is employed for achieving a simple replacement of the detachable calf support. Only in this embodiment, when the detachable calf support is connected to the heel cup, will the detachable

calf support fill the inside of the heel cup (the detachable calf support will be arranged between the heel cup and the heel of the boot), where, when the detachable calf support is removed, the gap between the heel cup and the heel of the boot has to be replaced by an insert which exactly fills up this gap. In this embodiment the rotational point will preferably be internally in the heel cup on each side of the heel.

5 The rotational point for the detachable calf support is also its principal attachment, but since the detachable calf support is attached on the inside of the heel cup, the detachable calf support will be pressed against the inside of the heel cup during use, thereby in addition being locked between the heel cup and the boot. This may be

10 accomplished in many ways, but we have focussed here on attachment means which do not require the use of tools. Here too it may be expedient to include locking mechanisms which prevent the detachable calf support from falling off.

The common feature of all the embodiments is that they can be combined with different embodiments of the detachable calf support. Everything from a full-height insert down to an insert which does not reach over the heel cup may be used. This is

15 a part of the concept which entails making a binding with a selection of different calf supports, and involving a binding which can be used without calf support.

Several embodiments of the present invention will now be explained with reference to the figures, in which

20 Figure 1 illustrates a first embodiment of a binding according to the present invention, where a replaceable calf support is inserted in a heel cup in the binding, viewed from above and from the side,

Figure 2a illustrates a second embodiment of a binding according to the present invention, where the inside of the heel cup is provided with an insertion groove in the heel cup's longitudinal direction for receiving a replaceable calf support,

25

Figure 2b illustrates a similar embodiment of the binding to that depicted in figure 2a, where in addition the heel cup is provided with a separate hinged part,

Figure 3 illustrates a fourth embodiment of a binding according to the present invention, where the inside of the heel cup is provided with a number of recesses,

30 Figure 4 illustrates yet another embodiment of a binding according to the present invention, where the outside of the heel cup is provided with recesses for insertion of a replaceable calf support,

Figure 5 illustrates a sixth embodiment of a binding according to the present invention, where the inside of the heel cup is provided with recesses for insertion of a replaceable calf support,

35

Figures 6 and 7 illustrate similar embodiments of recesses on the inside of the heel cup to that depicted in figure 5,

Figure 8 illustrates a possible locking mechanism which may be employed for preventing the detachable calf support from falling off, and

5 Figure 9 illustrates another embodiment of a binding according to the present invention.

In figure 1 a first embodiment is illustrated of a binding 1 for a snowboard according to the present invention, viewed from above and from the side, where the binding 1 is composed of a receiver part 2 and a locking part (not shown) for a snowboarder's boot (not shown). The receiver part 2 is then designed for receiving the boot (not shown), where the locking part (not shown) is then employed for securing or releasing the boot with respect to the binding 1. The receiver part 2 is further provided with a surface 3 which has to be connected with the top of the snowboard in a suitable manner, for example by means of various attachment devices such as screws, bolts, double-sided tape etc., in order thereby to form a fixed connection between the binding 1 and the snowboard (not shown). In addition the receiver part 2 may comprise an adjustment device (not shown), thereby enabling the binding's 1 position to be adjusted relative to the snowboard's longitudinal axis. The receiver part 2 further comprises a loop 4, a so-called heel cup, which is intended to abut against the heel of the boot when the boot is locked in the binding 1. The loop 4 is provided with two recesses 5, formed diametrically opposite each other, where these recesses 5 extend from the top 9 of the loop 4 a distance down into the receiver part 2 towards the top of the snowboard. A detachable calf support (a so-called highback) 6 will then be provided with protruding portions 7 which are complementary to the recesses 5 in the loop 4, thereby enabling the detachable calf support 6 to be attached or connected to the receiver part 2 by means of the recesses 5 and the protruding portions 7. In addition a lower surface 8 of the detachable calf support 6 will be provided complementarily with the top 9 of the loop 4, with the result that the lower surface 8 of the detachable calf support 6 will abut against the top 9 of the loop 4 when the detachable calf support 6 is connected to the receiver part 2, as illustrated on the right side of figure 1.

On the left side of figure 1 it is shown how the detachable calf support 6 is attached or connected to the receiver part 2. The detachable calf support 6 will then be arranged in a forward-facing position, thereby enabling the protruding portions 7 to be inserted into the recesses 5 in the loop 4. The detachable calf support 6, with the protruding portions 7 inserted into the recesses 5, will then be rotated towards the loop 4, with the result that the lower surface 8 of the detachable calf support 6 is brought into abutment against the top 9 of the loop 4, as illustrated on the right side of figure 1.

The recesses 5 in the loop 4, however, must be of such a shape that they permit the detachable calf support 6 to be adjusted relative to the loop 4 by means of an adjusting device 10, in order thereby to fit the detachable calf support 6 against the back of a snowboarder's calf, as well as to permit the detachable calf support 6 to be rotated forwards and down against the top of the snowboard, thereby making the snowboard more compact during transport and storage.

When a boot is connected to the binding 1, the detachable calf support 6 will be unable to fall off, due to the fact that the boot, which abuts against the inside of the detachable calf support 6, will prevent the detachable calf support 6 from rotating about the recesses 5 in the loop 4, but to prevent the detachable calf support 6 from coming loose from the recesses 5 in the loop 4 when there is no boot in the binding 1, a locking mechanism (not shown) may be provided in the loop's 4 recesses 5, which locking mechanism may either be designed so as to press against the protruding portions 7 of the detachable calf support 6, about their rotational point, or there may be a locking mechanism which prevents the protruding portions 7 from sliding out of the recesses 5 in the loop 4. Another alternative is to provide the detachable calf support 6 resilient or elastic, this elasticity being employed for squeezing the protruding portions 7 together slightly, thereby enabling the protruding portions 7 to be inserted in the recesses 5 in the loop 4 in this compressed position. When the detachable calf support 6 is attached in the recesses 5, the detachable calf support 6 will attempt to reassume its original position (i.e. it will spring outwards), with the result that the detachable calf support will be secured in the recesses 5.

A person skilled in the art will know how such a locking mechanism should be designed, and it will therefore not be further discussed here.

When the detachable calf support 6 is removed from the loop 4 in the receiver part 2, the boot's position in the binding 1 will be defined by the inside of the loop (the heel cup), which will be sufficient for positioning the boot correctly in the binding 1, but in addition the receiver part 2 may be provided with protrusions or the like (not shown) in front of the recesses 5, in order to give further support to the boot in the binding 1.

The detachable calf support 6 will be able to be removed from the binding's 1 receiver part 2 by means of a method which is the opposite of the insertion method.

Figures 2a and 2b illustrate two alternative embodiments of the binding 1 according to the present invention, viewed from above and from the side, where the receiver part's 2 loop 4 is provided with two recesses 5 arranged opposite each other, which recesses 5 are further connected with guide grooves 11 extending a length in the loop's 4 longitudinal direction. The recesses 5 and the guide grooves 11 will then be designed so as to interact with complementarily formed guide grooves 12 in the detachable calf support 6. When the detachable calf support 6 has to be connected to

the receiver part 2, the detachable calf support 6 will be slightly compressed, thereby bringing the guide grooves 12 into contact with the recesses 5 in the loop 4, this being illustrated on the left side of figures 2a and 2b.

5 The detachable calf support 6 will thereafter be released, whereby, on account of the detachable calf support's 6 elastic or resilient properties, the guide grooves 12 will bring the guide grooves 12 into contact with the guide grooves 11 in the loop 4. This is illustrated in the middle of figures 2a and 2b. Since the guide grooves 11 extend a certain length in the loop's 4 longitudinal direction, the detachable calf support 6 can now be pushed backwards towards the rear edge of the loop 4, in the direction of the arrow P, until the guide grooves 12 reach the end of the guide grooves 11. This is illustrated on the right side of figures 2a and 2b.

10 The guide grooves 12 and the guide grooves 11 may, for example, be designed in a complementary shape, for example a T-shape or the like, in order to prevent the guide grooves 12 from "jumping" out of the guide grooves 11. It should be understood, however, that other shapes may also be employed for implementing this function.

In a similar manner to the embodiment illustrated in figure 1, the detachable calf support 6 will comprise an adjusting mechanism 10 for permitting an adjustment of the detachable calf support 6 relative to the loop 4.

20 In a preferred embodiment of the present invention the detachable calf support 6 and the guide grooves 12 may be provided as separate parts, whereupon they will be able to be rotated relative to each other via a bolt B or the like. This will mean that the detachable calf support 6 will be able to be folded down against the receiver part's 2 surface 3. Alternatively, the guide grooves 12 may be an integrated part of the detachable calf support 6, in which case the detachable calf support 6 is not capable of being folded down.

30 In figure 2b the rotation of the detachable calf support will be permitted by the actual loop 4 being in the form of a hinged element, where an upper part 4a of the loop 4 is connected via a bolt B or the like to a lower part 4b of the loop 4. The bolt B will then form a rotational point for the upper part 4a of the loop 4, thereby enabling the detachable calf support 6, which is connected to the upper part 4a of the loop 4, to be folded forwards against the receiver part's 2 surface 3.

35 Recesses 5 and guide grooves 11 will then be provided in the upper part 4a of the loop 4. In this embodiment the guide grooves 12 will be integrated in the detachable calf support 6, thereby preventing guide groove 12 and the detachable calf support 6 from being moved relative to each other.

The detachable calf support 6 will be able to be removed from the binding's 1 receiver part 2 by means of a method which is opposite to the insertion method.

Figure 3 illustrates yet another embodiment of the binding according to the present invention, viewed from above and from the side, where an inside of the loop (the heel cup) 4 is provided with a number of recesses 5a, in which recesses 5a a number of tongues 13 extending downwardly from the detachable calf support 6 are arranged when the detachable calf support 6 is connected to the binding's 1 receiver part 2. The loop 4 is further provided with two recesses 5 arranged opposite each other. The detachable calf support 6 will further be provided with two locking elements 14, where the locking elements 14 are locked in the recesses 5 in the loop 4. In a similar manner to the embodiment according to figure 1, the detachable calf support 6 will first be connected to the loop 4 by the locking elements 14 being inserted in the recesses 5, whereupon the detachable calf support 6 is rotated down against the top 9 of the loop 4, with the result that the downwardly extending tongues 13 are placed in the recesses 5a on the inside of the loop 4. The right side of figure 3 shows details of the locking elements 14 and the recesses 5 in the loop. For the sake of simplicity, only right locking element 14 of the detachable calf support 6, viewed in the snowboard's normal direction of travel, is illustrated inserted in a recess 5 on the right side (on the inside) of the loop 4. In this case the recess 5 will comprise an opening which can receive the locking element 14, and a slot 15 extending from the opening, where the slot 15 comprises a locking lip 15a. When the locking element 14 is inserted in the opening in the recess 5, the locking element 14 has to be moved inwards in the slot 15, in order to be locked against the locking lip 15a. The locking element 14 then has a shape which together with the locking lip 15a permits locking.

The advantage of this embodiment is that during use the boot presses the tongues 13 of the detachable calf support 6 against the loop (the heel cup) 4, in order thereby to both lock and stiffen the detachable calf support 6. In this embodiment also the detachable calf support 6 can be rotated forwards and folded down, but it can also be locked in a position with a slightly forward-leaning calf support. In this case, as in all the other embodiments, consideration must be given as to whether to be satisfied with a snap-in system without an extra locking mechanism, or whether to lock the detachable calf support 6 in or round the rotational point. At all events locking mechanisms are preferred which do not require the use of tools.

Figure 4 illustrates an embodiment of the binding 1 according to the present invention, viewed from above and from the side, where the detachable calf support 6 is now mounted on the outside of the binding's 1 receiver part 2. The outside of the loop 4 will then be provided with two recesses 5 formed opposite each other, where the recesses 5 are arranged for receiving and locking of the detachable calf support's 6 two locking elements 14. Recesses 5 and locking elements 14 may be de-

signed in a similar manner to that described in the embodiment illustrated in figure 3. In this embodiment, however, the detachable calf support 6 will not be provided with the tongues 13 and the loop 4 will not be provided with the recesses 5a.

5 However, the locking elements may also be formed to allow the calf support 6 to be adjusted through the locking elements 14. By moving the calf support's 6 locking elements 14 in the recesses 5, the calf support 6 will rotate about the loop (heel cup) 4, whereby it is achieved an adjustment of the calf support 6 (forward lean). The locking elements 14 will then be designed to be located on a straight or curved line, where this forms an angle between 40 to 70 degrees with the binding's 1 surface 3, 10 when the calf support 6 is inserted in the binding 1.

The right side of figure 4 illustrates details of the locking elements 14 and the recesses 5 in the loop. For the sake of simplicity, only left locking element 14 of the detachable calf support 6, viewed in the snowboard's normal direction of travel, is illustrated inserted in a recess 5 on the left side (on the outside) of the loop 4. In this 15 case the recess 5 will comprise an opening which can receive the locking element 14, and a slot 15 extending from the opening, where the slot 15 comprises a locking lip 15a. When the locking element 14 is guided into the opening in the recess 5, the locking element 14 has to be moved inwards in the slot 15, in order to be locked against the locking lip 15a. The locking element 14 then has a shape which together 20 with the locking lip 15a permits locking.

The insertion in the rotational point (the recesses 5) is conducted in such a manner that when the calf presses the detachable calf support 6 backwards, the detachable calf support 6 cannot come loose.

Figure 5 illustrates a further embodiment of the binding 1 according to the present 25 invention, viewed from above and from the side, where the detachable calf support 6 in this embodiment is mounted on the inside of the loop 4. For an explanation of how the detachable calf support 6, the loop 4, recesses 5 and locking elements 14 are designed, we refer to figure 4, as these are identically designed. In this embodiment, however, when the detachable calf support 6 is removed, there will be a gap 30 between the heel of the boot and the inside of the loop 4 (due to the fact that the detachable calf support 6 has a certain thickness), where this gap may cause the boot to be able to move in the binding 1. In order to compensate for this gap, an insert I, which insert I is also provided with locking elements 14, may be employed to replace the detachable calf support 6 when it is removed. In a similar manner to the 35 detachable calf support 6, the insert I will then be connected to the recesses 5 arranged on the inside of the loop 4. The insert I will further comprise a lip 16, where this lip 16 will abut against the loop's upper edge 9 when the insert I is correctly arranged in the loop 4.

In this case, as in all the other described embodiments, consideration must be given as to whether to be satisfied with a snap-in system without an extra locking mechanism, or whether to lock the detachable calf support 6 in or round the rotational point (the recesses 5). At all events locking mechanisms are preferred which do not
5 require the use of tools.

The recesses 5 which are described in connection with figures 4 and 5, could also be designed such that they allow the calf support 6 to be adjusted through the recesses 5. By moving the calf support's 6 locking elements 14 in the recesses 5, the calf support 6 will rotate about the loop (heel cup) 4, whereby it is obtained an adjust-
10 ment of the calf support (forward lean). The recesses 5 could then be designed to be located on a straight or curved line, where this forms an angle between 40 to 70 degrees with the binding's 1 surface 3.

Figures 6 and 7 illustrate alternative embodiments of the detachable calf support's 6 locking elements 14 and the loop's 4 recesses 5 which are described in connection
15 with figures 3, 4 and 5, where it should be understood that the detachable calf support 6 may be arranged on the outside or the inside of the loop 4, where the loop 4 may be provided with recesses 5a on the inside of the loop 4 and the detachable calf support 6 may be provided with downwardly extending tongues 13. In figure 6 the detachable calf support's 6 locking element 14 may be conical in shape, whereby
20 the loop's 4 recess will also be in conical form. The detachable calf support 6 and/or the insert will then be compressed, in order thereby to guide the locking elements 14 into engagement with the recesses 5, whereupon the locking elements 14 are moved in the recesses 5, in order to be locked thereto. Figure 7 illustrates an even simpler design of the detachable calf support's 6 locking elements 14, with
25 correspondingly simpler recesses 5, the locking elements 14 and the recesses 5 being in the form of complementary circles, square or polygonal openings, where locking of the locking elements 14 in the recesses 5 is accomplished by the detachable calf support 6 and the insert I being squeezed together and guided into engagement with the recesses 5. When the detachable calf support 6 or the insert I is
30 released, their resilient or elastic properties will cause the locking elements 14 to be retained in engagement with the recesses 14.

Figure 8 illustrates a similar embodiment of a binding according to the present invention to that depicted in figure 5, but where the loop 4 comprises a locking device for preventing the detachable calf support 6 from inadvertently falling off. Since
35 recesses 5 and locking elements 14 are designed in the same way as illustrated in figures 3, 4 and 5, we refer to the description of these figures. Only the locking device 20 will be explained here in greater detail. The locking device 20 is mounted on the outside of the loop 4, where a locking pin 21 in the locking device 20 extends through an opening 22 which is connected to the recess 5. When the detachable calf
40 support's 6 locking element 14 is guided into the recess 5 in the loop 4, the locking

pin 21 will be moved in the opening 22, whereby the locking element 14 is moved inwards in the slot 15, in order thereby to be locked against the locking lip 15a. In this position the locking element 14 will have been moved so far forward in the slot 15 that the locking pin 21, which is spring-loaded (not shown), will assume its
5 original position (illustrated in the top picture on the right side), with the result that the locking pin 21 will abut against an end of the locking element 14 which is opposite an end of the locking element 14 which abuts against the locking lip 15a. The locking device 20 also comprises a release pin 23, which is used to bring the locking pin 21 out of abutment with the end of the locking element 14 when the detach-
10 able calf support 6 has to be removed from the loop 4.

Figure 9 illustrates yet another embodiment of a binding according to the present invention, where the receiver part 2 can now be made with a thinner loop (heel cup) 4, in which case the thinner loop 4 is produced as a separate unit which can be connected in a suitable manner to the receiver part 2. The separate loop 4 may, for ex-
15 ample, be made of a metal. In addition, the recess 5 in the loop 4 here will not be connected to a slot 15, but the locking elements 14 will be of a similar design to that illustrated, for example, in figure 5.

20

25

30

CLAIMS

1. Binding (1) for mounting on a snowboard, where the binding (1) is attached to the snowboard by one or more known attachment devices, characterised in that the binding's (1) receiver part (2) comprises a loop (4) provided with recesses (5), which recesses (5) are formed to take up a detachable calf support (6), as the binding (1) will have approximately the same fit and position for a boot with or without the calf support (6), where this is achieved either with that it is sufficient support remaining for the boot in the loop (4) or by that the calf support (6) with a simple grip can be replaced with an insert (I) which will fill up as much on an inside of the loop (4) as the calf support (6) did.
2. Binding (1) for mounting on a snowboard according to claim 1, characterised in that the calf support (6) is positioned within the binding's loop (heel cup) (4), so that when the calf support (6) is removed, the insert (I) will have a same function to fill a gap in the loop (heel cup) (4), so that the boot fits equally well into the binding (1) even without the calf support (6).
3. Binding (1) for mounting on a snowboard according to claim 1, characterised in that the calf support (6) only extends piecemeal down on the inside of the loop (heel cup) (4), so that when the calf support (6) is removed, no insert (I) is required on the inside of the loop (heel cup) (4) in order to keep the boot in approximately the same place as it had while the calf support (6) was in position.
4. Binding (1) for mounting on a snowboard according to one or more of the preceding claims 1-3, characterised in that binding (1) comprises an own locking mechanism which prevents the calf support (6) from falling out.
5. Binding (1) for mounting on a snowboard according to one or more of the preceding claims 1-4, characterised in that the calf support (6) is attached by a snap-in system based on the principle that the calf support (6) is stiff enough to keep itself in position when it is inserted and soft enough to enable it to be removed and inserted by hand.
6. Binding (1) for mounting on a snowboard according to one or more of the preceding claims 1-5, characterised in that the calf support (6) can be removed and inserted without the use of tools.

7. Binding (1) for mounting on a snowboard according to one or more of preceding claims 1-6,
characterised in that the calf support (6) can be adjusted by a certain forward angle with rotation about the loop (heel cup) (4) by adjusting fastening point of the calf support (6) in the recesses (5), substantially radially on a rotation point.
8. Binding (1) for mounting on a snowboard according to claim 1 or 7, characterised in that the calf support (6) can be folded down forward in the binding (1).
9. Binding (1) for mounting on a snowboard according to claim 1, characterised in that the loop (heel cup) (4) can be adjusted in the shoe's longitudinal direction in the binding (1) before the shoe is inserted.
10. Binding (1) for mounting on a snowboard according to one or more of the preceding claims 1-9,
characterised in that the binding (1) is provided with an adjustable strap or cap over the toes to hold the boot in position.
11. Binding (1) for mounting on a snowboard according to one or more of the preceding claims 1-10,
characterised in that the binding (1) is provided with an adjustable strap or cap over the instep of the foot in order to hold the boot in position.

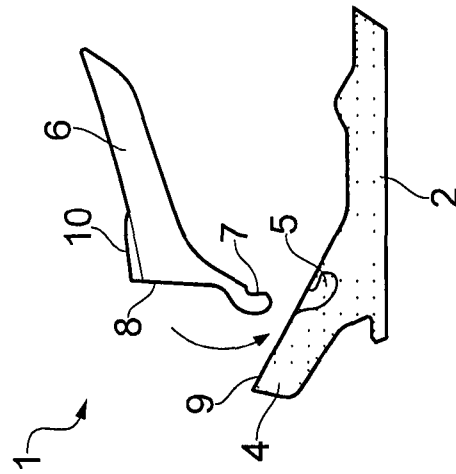
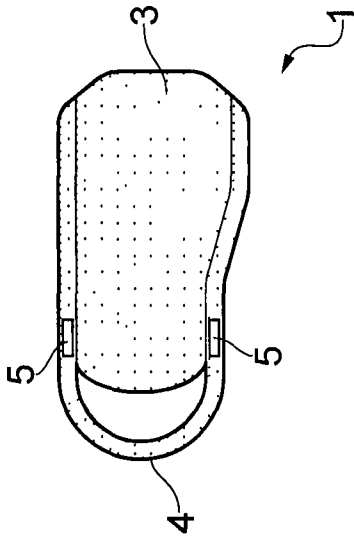
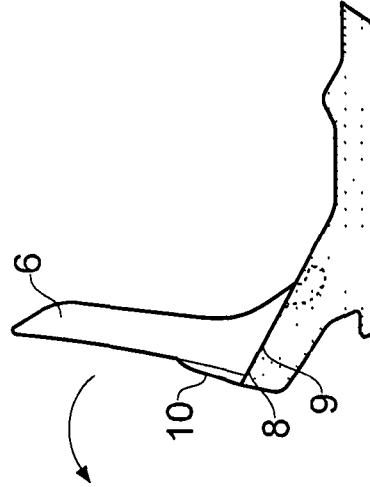
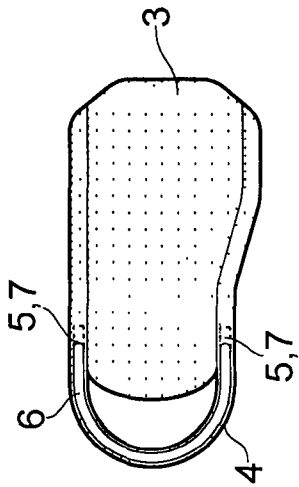

FIG. 1

2/10

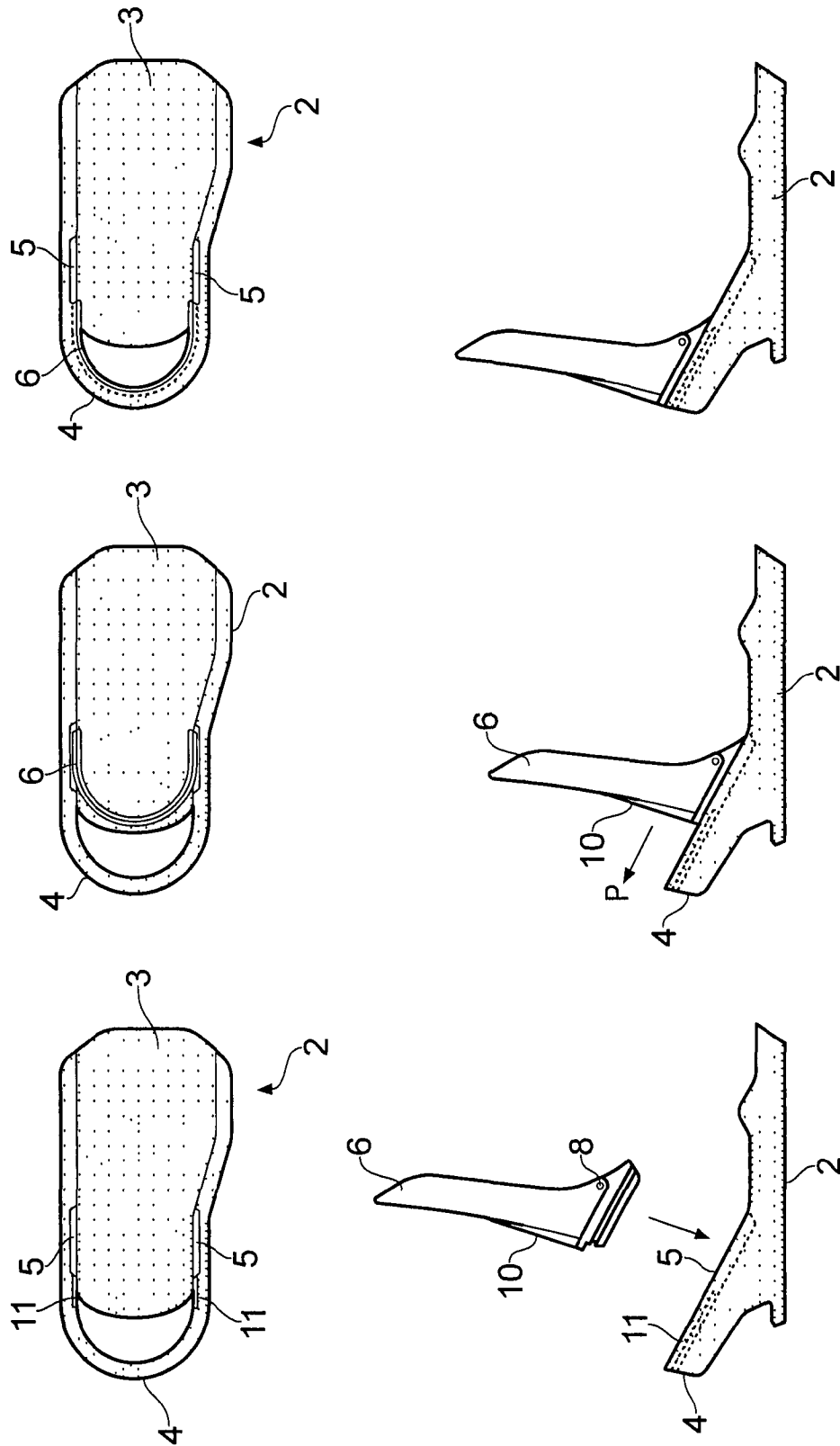

FIG. 2a

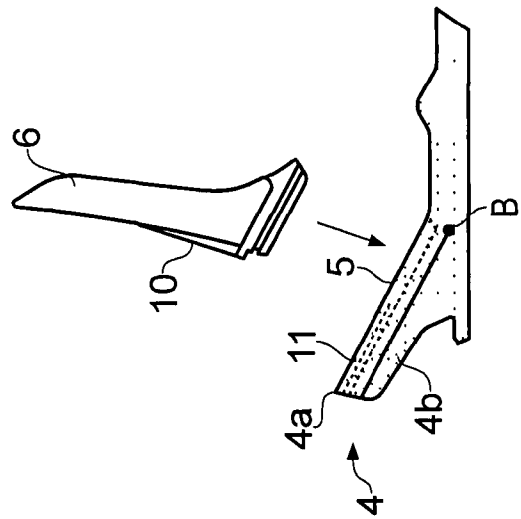
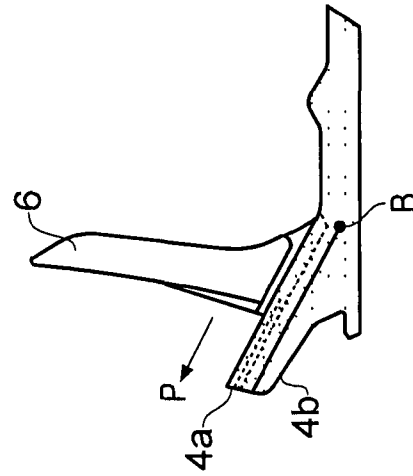
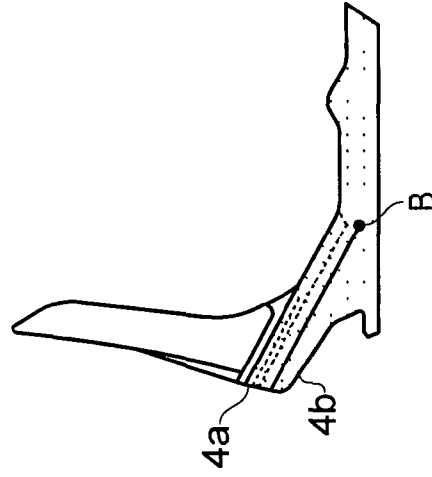
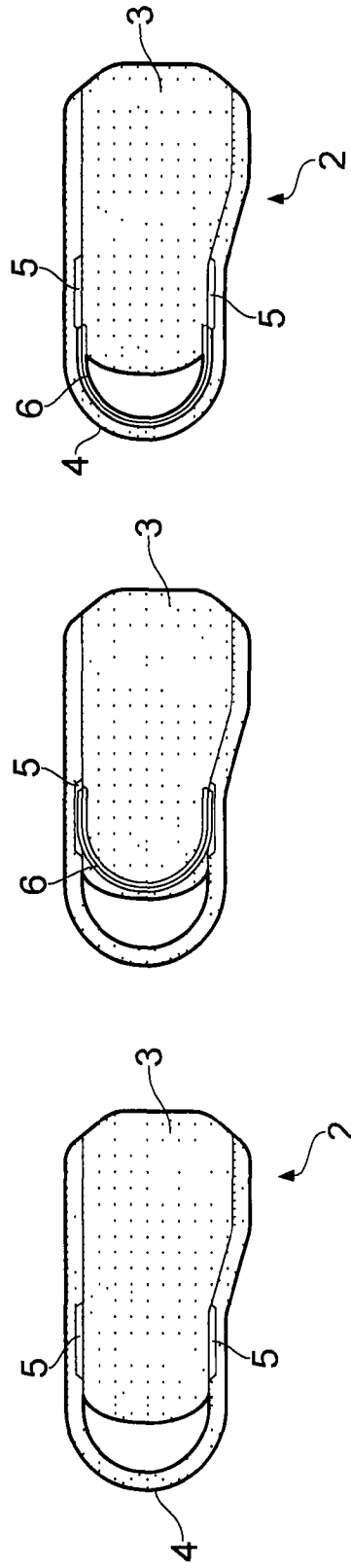

FIG. 2b

4/10

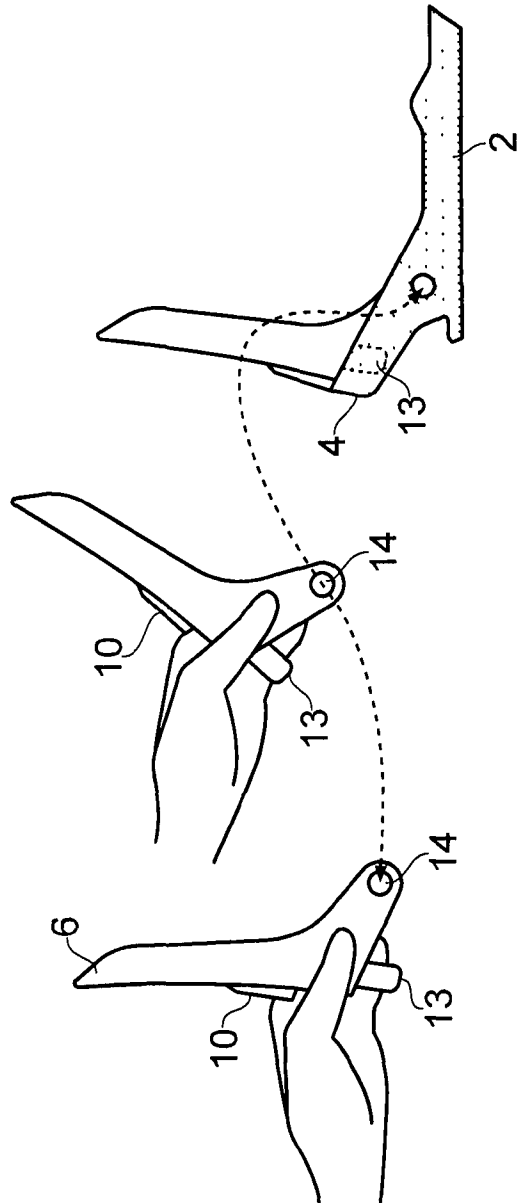
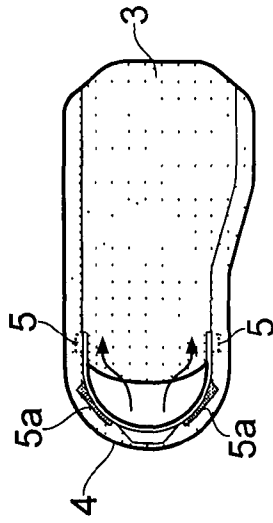
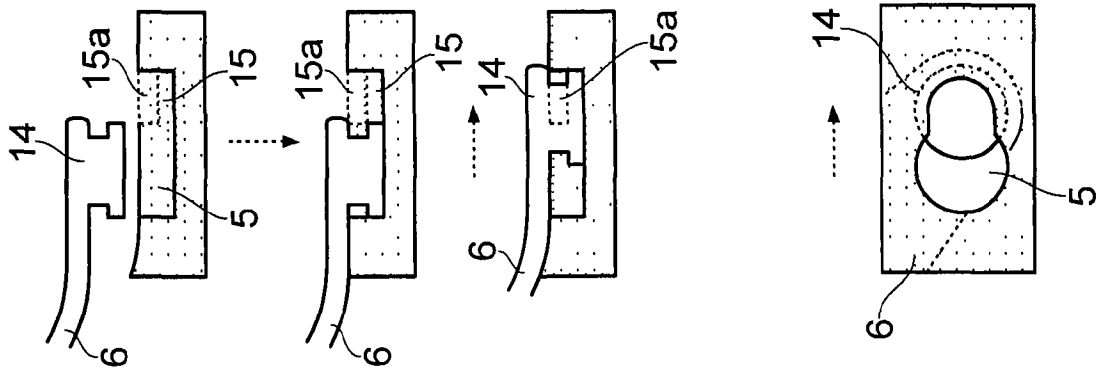

FIG. 3

5/10

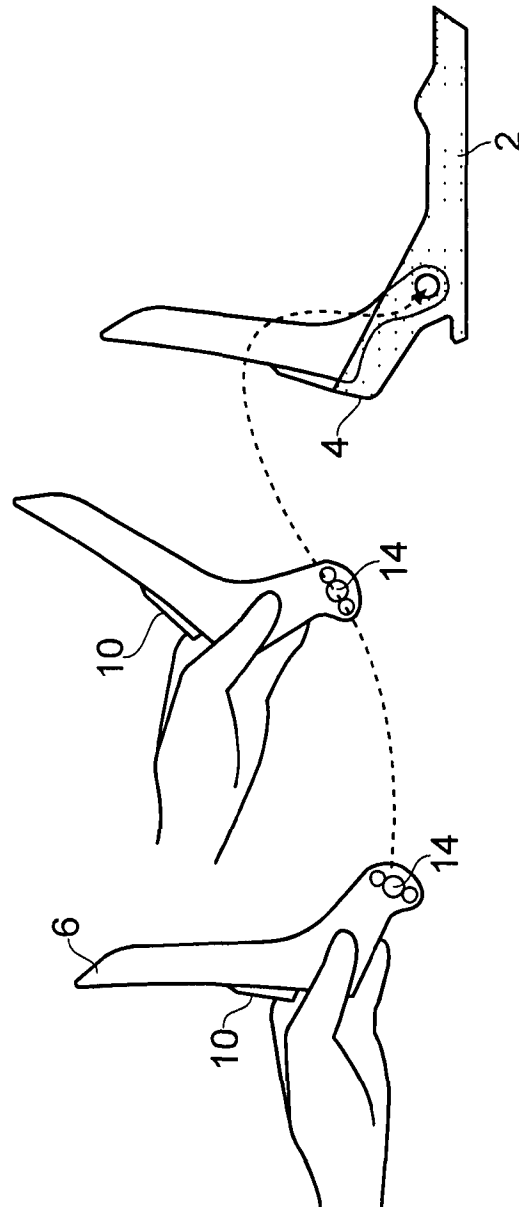
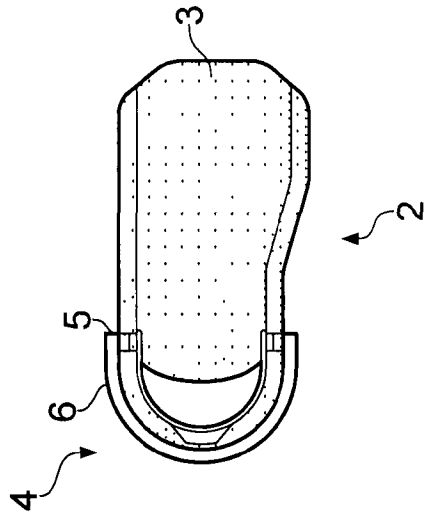
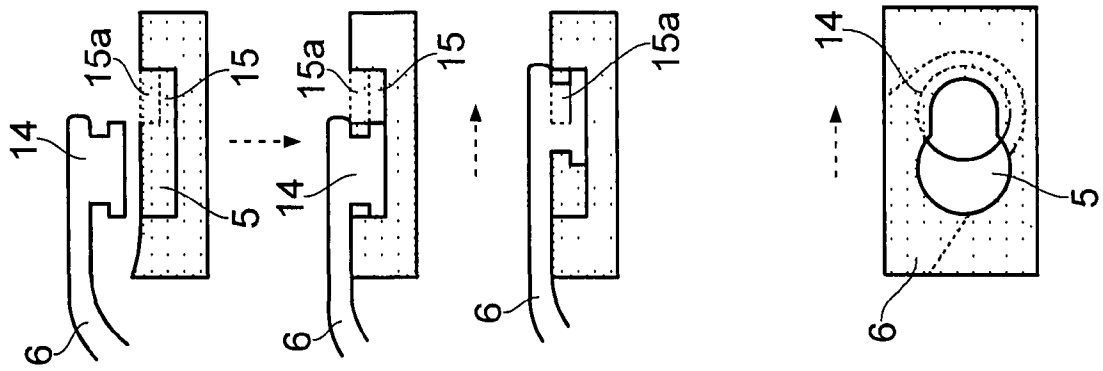

FIG. 4

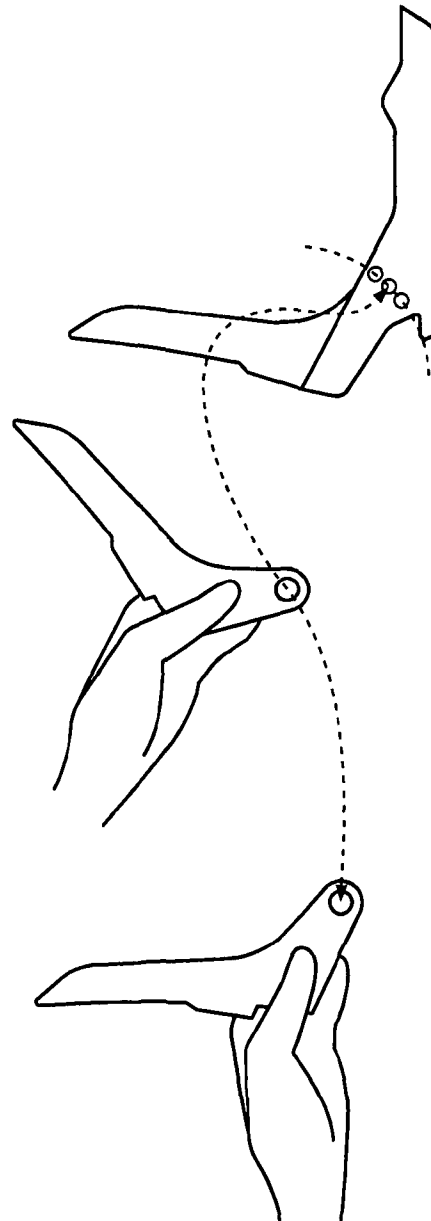
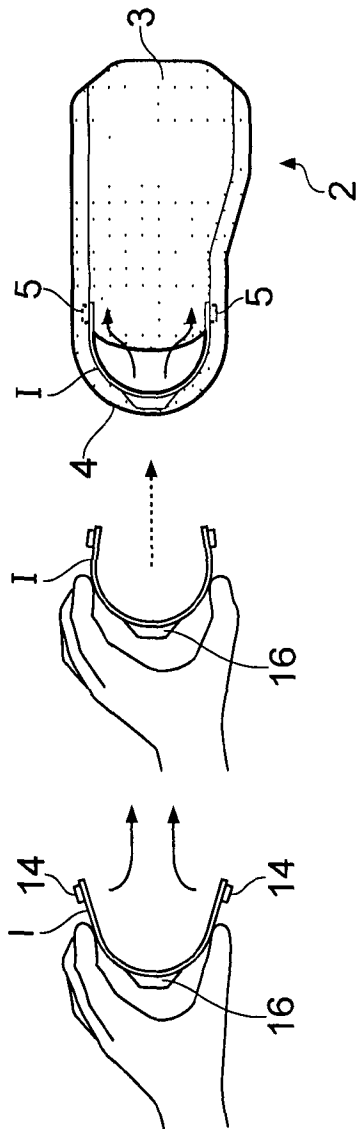
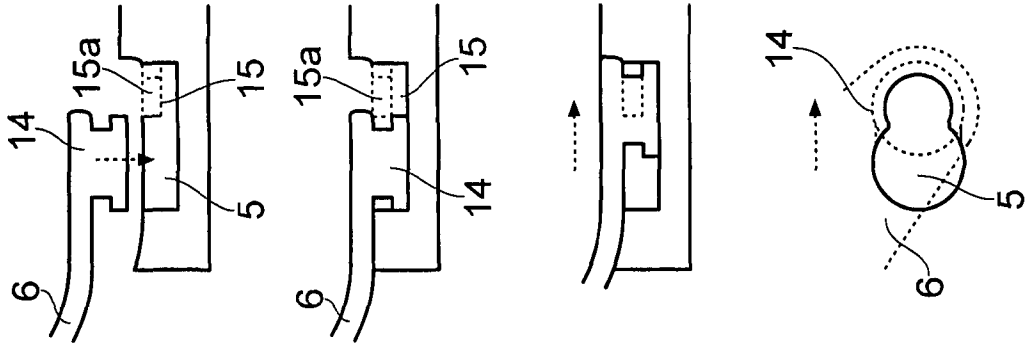

FIG. 5

7/10

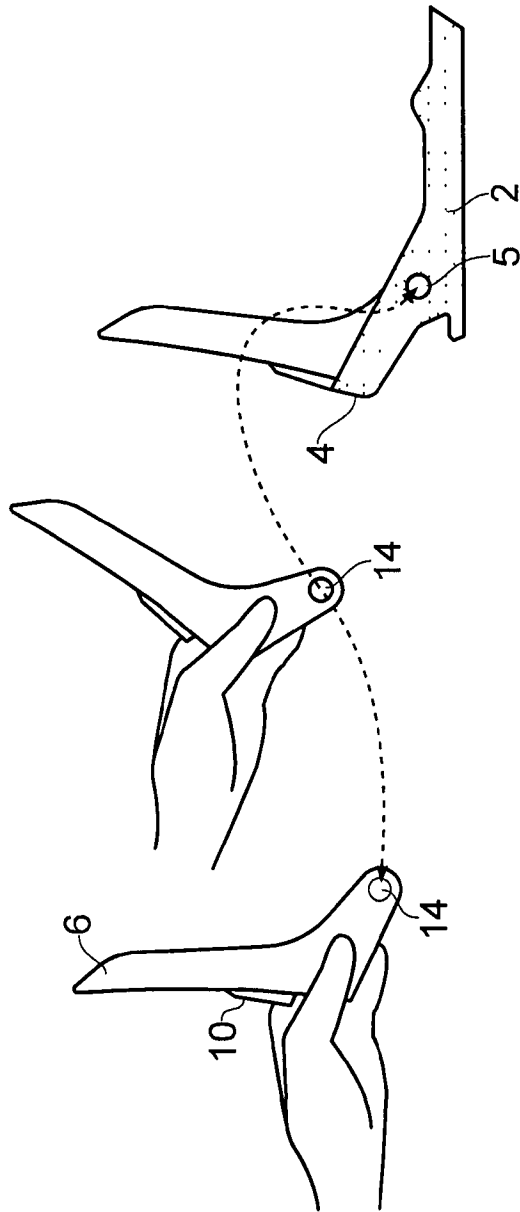
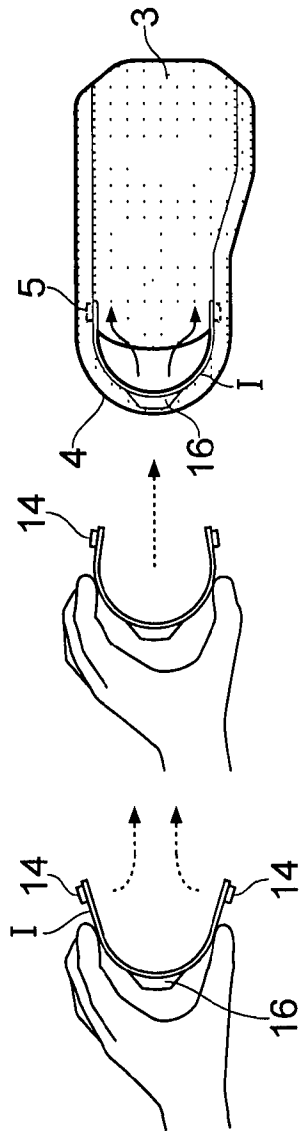
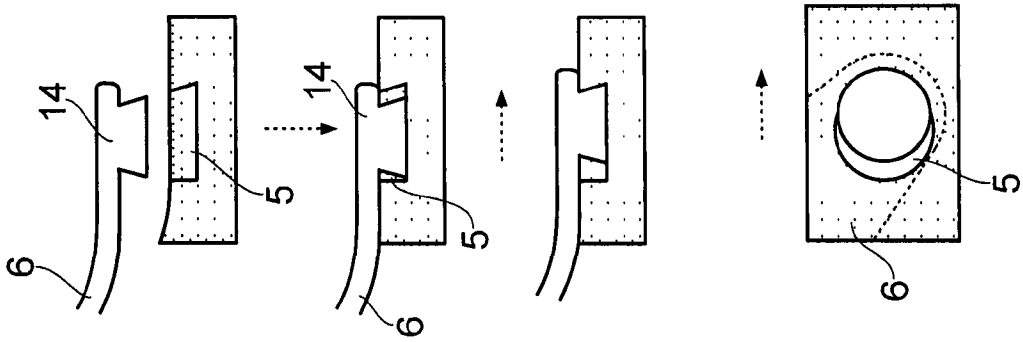

FIG. 6

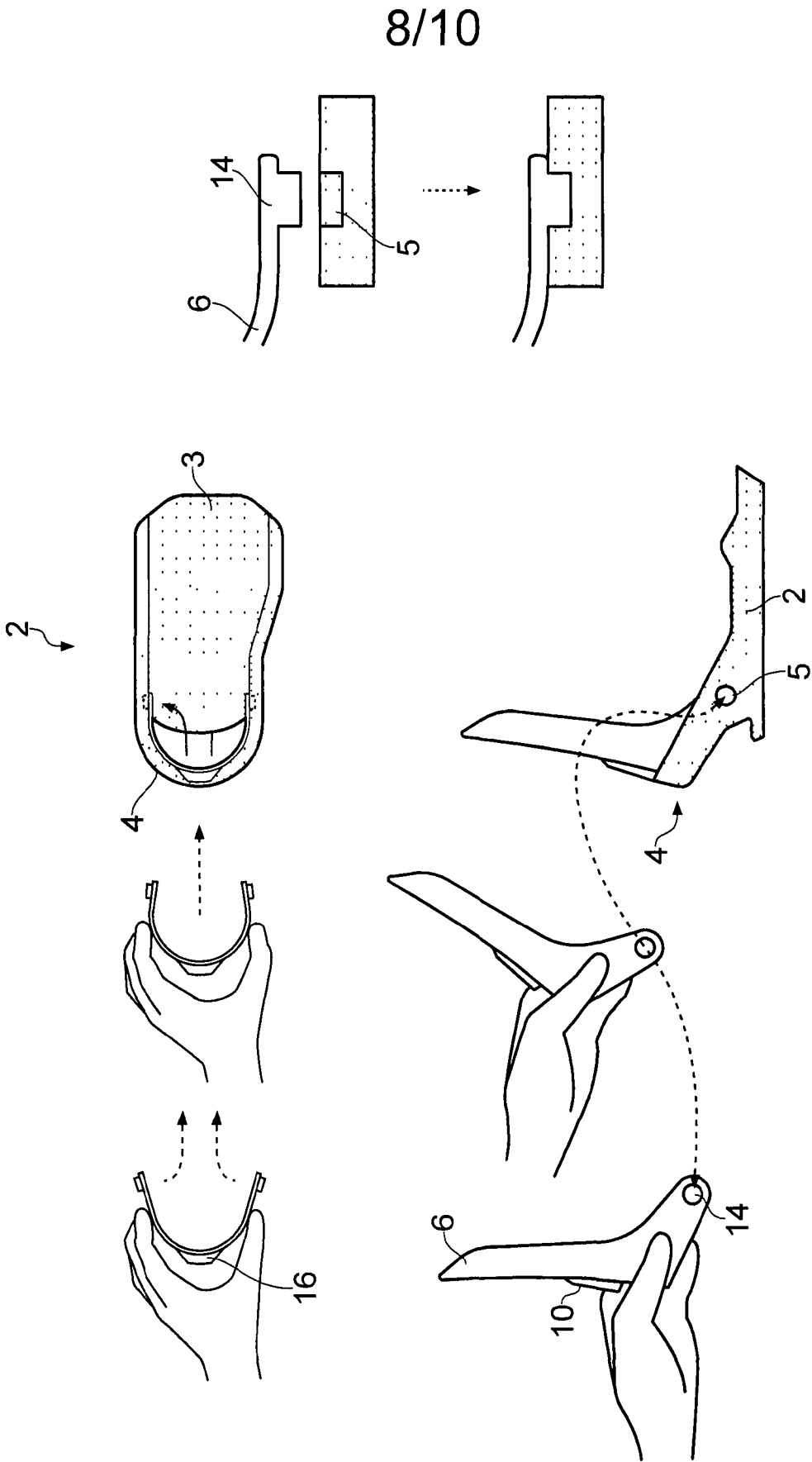

FIG. 7

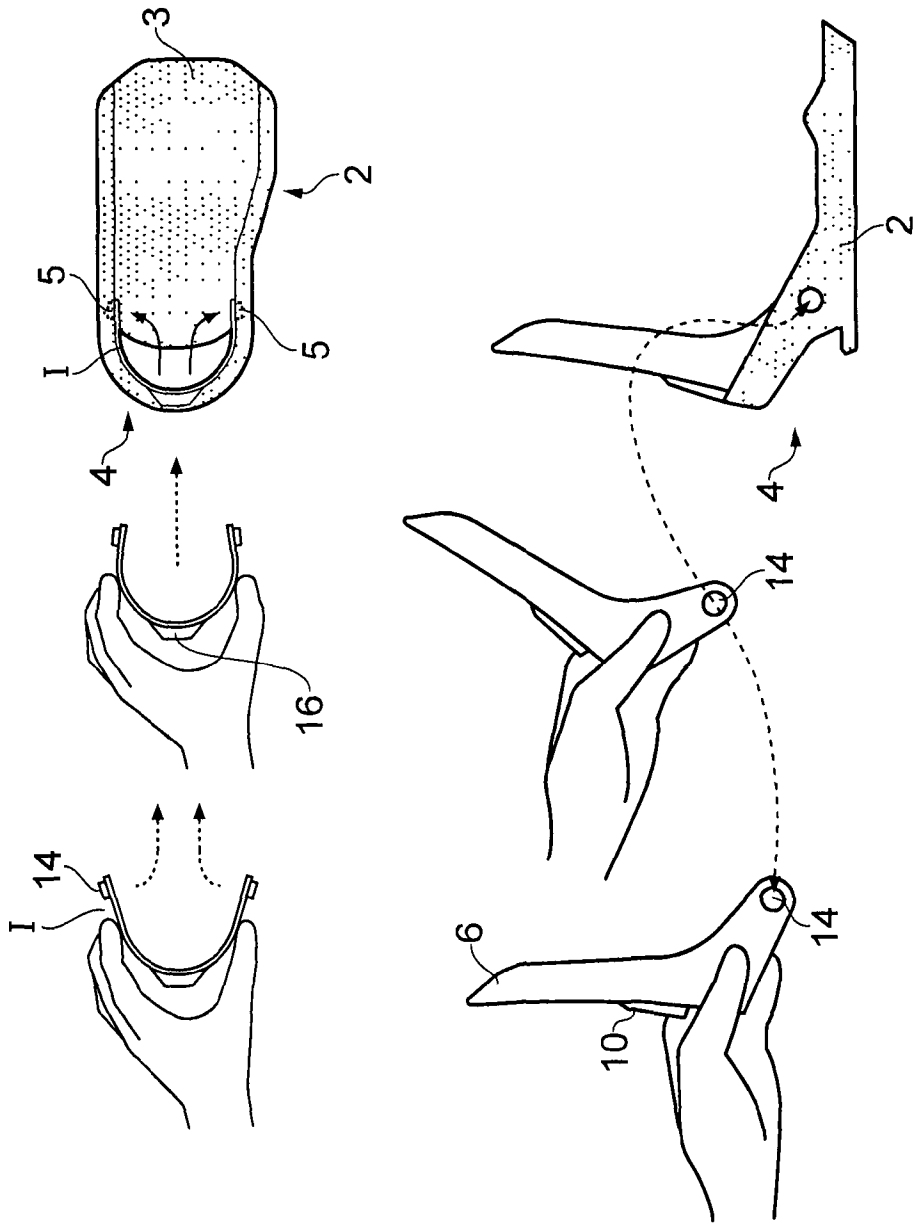
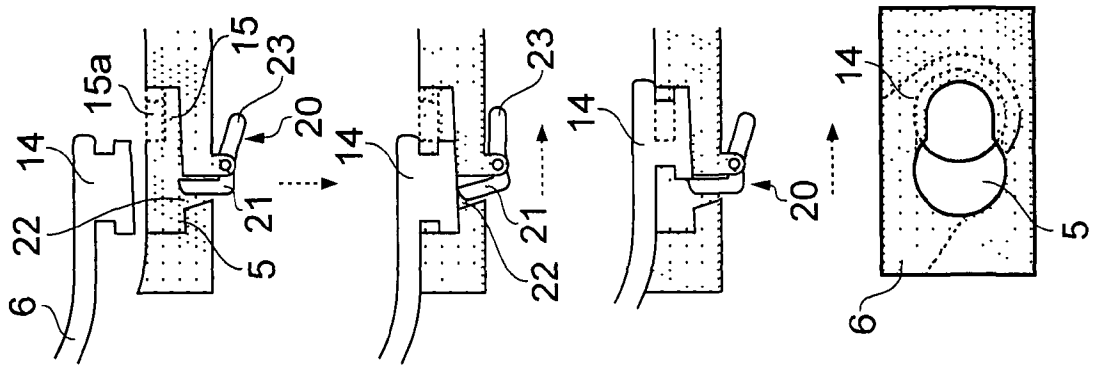

FIG. 8

10/10

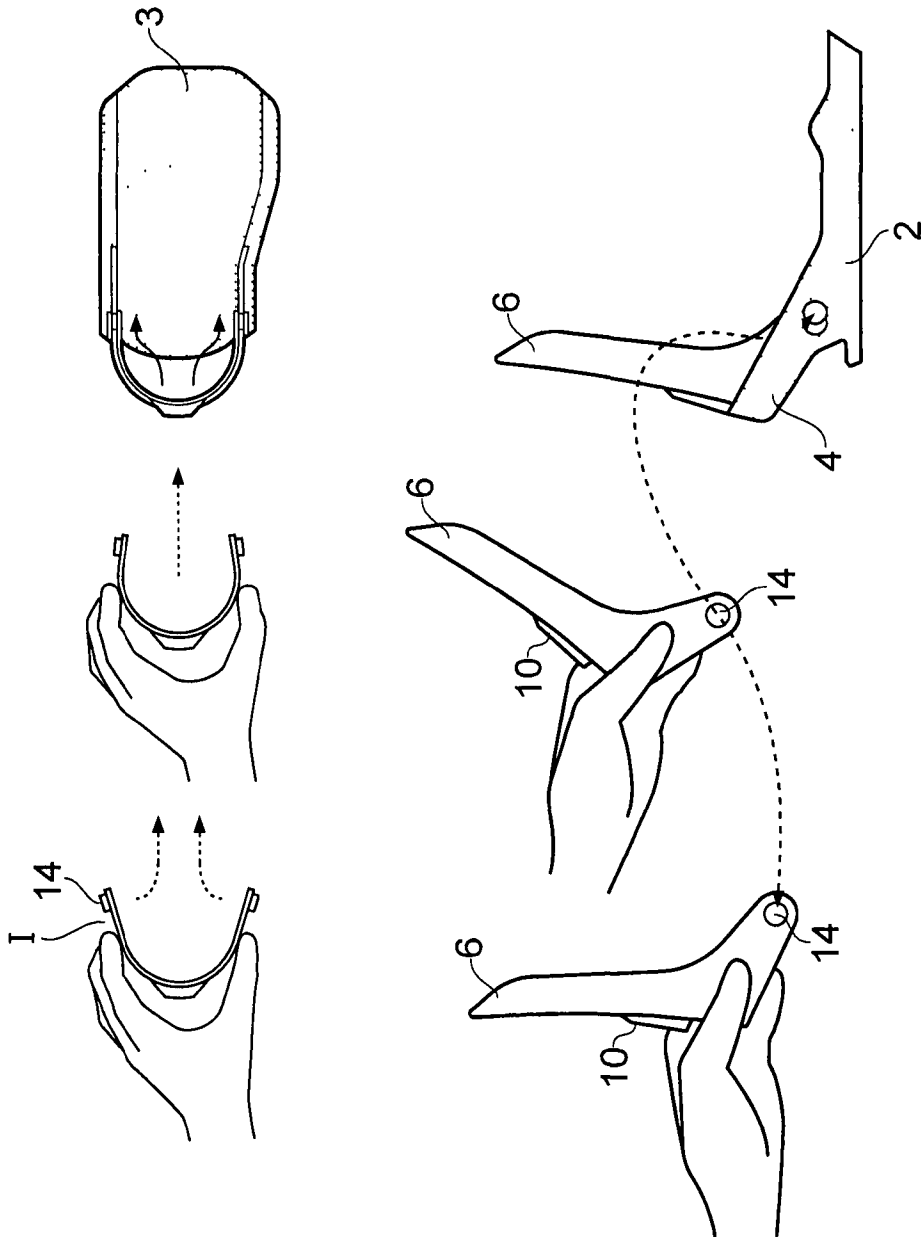
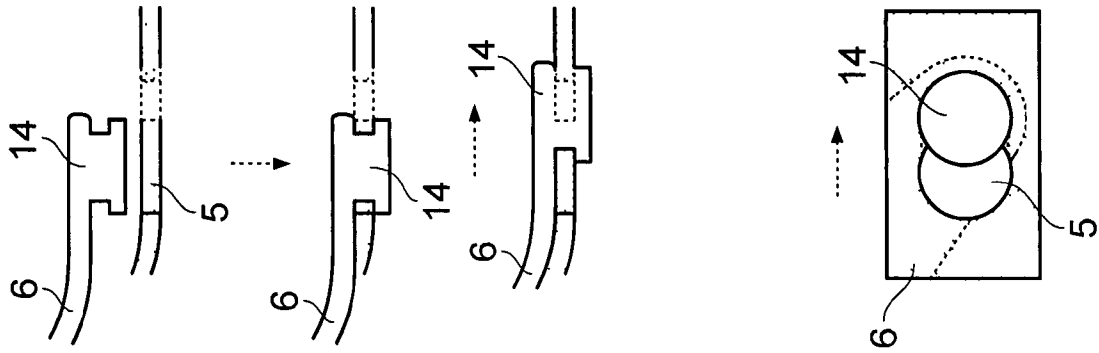

FIG. 9

INTERNATIONAL SEARCH REPORT

International application No PCT/N02012/000012

A. CLASSIFICATION OF SUBJECT MATTER
 INV. A63C10/24
 ADD.

According to International Patent Classification (IPC) or to both national classification and IPC

B. FIELDS SEARCHED

Minimum documentation searched (classification system followed by classification symbols)
 A63C

Documentation searched other than minimum documentation to the extent that such documents are included in the fields searched

Electronic data base consulted during the international search (name of data base and, where practicable, search terms used)

EPO-Internal, WPI Data

C. DOCUMENTS CONSIDERED TO BE RELEVANT

Category*	Citation of document, with indication, where appropriate, of the relevant passages	Relevant to claim No.
X	AT 409 937 B (INNOVATIONDESIGNCOMPANY PRODUK [AT]) 27 December 2002 (2002-12-27) pages 2-3; figure * -----	1-11
X	WO 2007/064889 A1 (DU PONT [US]; NIDECKER S A [CH]; NIDECKER S.A. [CH]) 7 June 2007 (2007-06-07) the whole document -----	1-11

Further documents are listed in the continuation of Box C.

See patent family annex.

* Special categories of cited documents :

"A" document defining the general state of the art which is not considered to be of particular relevance

"E" earlier application or patent but published on or after the international filing date

"L" document which may throw doubts on priority claim(s) or which is cited to establish the publication date of another citation or other special reason (as specified)

"O" document referring to an oral disclosure, use, exhibition or other means

"P" document published prior to the international filing date but later than the priority date claimed

"T" later document published after the international filing date or priority date and not in conflict with the application but cited to understand the principle or theory underlying the invention

"X" document of particular relevance; the claimed invention cannot be considered novel or cannot be considered to involve an inventive step when the document is taken alone

"Y" document of particular relevance; the claimed invention cannot be considered to involve an inventive step when the document is combined with one or more other such documents, such combination being obvious to a person skilled in the art

"&" document member of the same patent family

Date of the actual completion of the international search

20 September 2012

Date of mailing of the international search report

02/10/2012

Name and mailing address of the ISA/

European Patent Office, P.B. 5818 Patentlaan 2
 NL - 2280 HV Rijswijk
 Tel. (+31-70) 340-2040,
 Fax: (+31-70) 340-3016

Authorized officer

Haller, E

INTERNATIONAL SEARCH REPORT

Information on patent family members

International application No

PCT/N02012/000012

Patent document cited in search report	Publication date	Patent family member(s)	Publication date
AT 409937	B	27-12-2002	NONE

WO 2007064889	A1	07-06-2007	CN 101365519 A 11-02-2009
			EP 1957172 A1 20-08-2008
			JP 2009518067 A 07-05-2009
			KR 20090004843 A 12-01-2009
			US 2007187928 A1 16-08-2007
			WO 2007064889 A1 07-06-2007
