

(19) **DANMARK**

(10) **DK/EP 2929302 T3**



(12) **Oversættelse af
europæisk patentskrift**

Patent- og
Varemærkestyrelsen

-
- (51) Int.Cl.: **G 01 F 23/20 (2006.01)** *G 01 F 22/00 (2006.01)* *G 01 F 23/00 (2006.01)*
- (45) Oversættelsen bekendtgjort den: **2020-05-18**
- (80) Dato for Den Europæiske Patentmyndigheds bekendtgørelse om meddelelse af patentet: **2020-02-19**
- (86) Europæisk ansøgning nr.: **13861147.0**
- (86) Europæisk indleveringsdag: **2013-12-06**
- (87) Den europæiske ansøgnings publiceringsdag: **2015-10-14**
- (86) International ansøgning nr.: **US2013073653**
- (87) Internationalt publikationsnr.: **WO2014089477**
- (30) Prioritet: **2012-12-06 US 201261734225 P** **2013-12-05 US 201314098430**
- (84) Designerede stater: **AL AT BE BG CH CY CZ DE DK EE ES FI FR GB GR HR HU IE IS IT LI LT LU LV MC MK MT NL NO PL PT RO RS SE SI SK SM TR**
- (73) Patenthaver: **Osborne Industries, Inc., 120 N. Industrial Avenue, P.O. Box 388, Osborne, KS 67473, USA**
- (72) Opfinder: **EAKIN, George R., Osborne Industries, Inc., P.O. Box 388, Osborne, KS 67473, USA**
- (74) Fuldmægtig i Danmark: **Budde Schou A/S, Dronningens Tværgade 30, 1302 København K, Danmark**
- (54) Benævnelse: **System til måling af niveauet af tørt løsgodsmateriale i en beholder**
- (56) Fremdragne publikationer:
EP-A1- 1 041 369
DE-A1- 10 046 102
DE-A1- 10 305 716
RU-C1- 2 069 318
RU-C2- 2 273 003
US-A- 3 753 200
US-A- 4 043 199
US-A- 4 276 774
US-A- 5 493 903
US-A1- 2003 217 596
US-A1- 2006 142 974
US-A1- 2007 227 272
US-A1- 2011 025 512
US-B1- 6 217 752

DESCRIPTION

BACKGROUND OF THE INVENTION

Field of the Invention

[0001] The present invention relates generally to devices for measuring the depth of material in containers. In particular, the present invention relates to devices and methods for measuring the depth of dry bulk particulate materials, such as livestock feed, in a container, such as a bin.

Description of the Related Art

[0002] An ability to measure the level and amount of a dry bulk solid or a liquid or fluid level in a container is often needed to know the rate of use or disappearance of material from the container so that rate of material use can be accurately established to enable the user to monitor and control the use of the material being withdrawn from the container and to know when to restock the container with the material after it is predicted to be depleted. The inventory volume of a given container is also valuable in determining the value of material in the container. Such a measuring device also alerts an operator to avoid overfilling the container and can monitor the refilling operation to ensure that the container is totally filled, but not overfilled.

[0003] This requirement is particularly important for agricultural livestock feed bins which are frequently discharged and recharged with feed. Many ways have been developed for making this type of measurement, but all suffer from the problem of being inherently complicated and expensive to employ for low-added value applications like livestock feed, and even though expensive, are often unreliable in the harsh usage environments often found in rural locations where feed bins are employed. US 2003/0217596 discloses a system for measuring the level of dry bulk material inside the container according to the preamble of claim 1.

SUMMARY OF THE INVENTION

[0004] An object of the present invention is to provide a device and method for measuring the depth of dry bulk particulate materials in a container, which device and method are accurate, inexpensive, simple in operation, reliable in harsh usage environments, do not have moving parts subject to wear and damage, are not affected by temperature changes unrelated to material level, and are capable of a long operating life.

[0005] To accomplish these and other objects of the present invention, a system for measuring a level of dry bulk solids within a container is provided, which has a columnar device supported vertically within the container. The columnar device has a closed lower end and openings through a sidewall thereof for allowing dry bulk material within the container to flow into and out of the columnar device. A load cell is used to measure a weight of the dry bulk material within the columnar device, which is then correlated to the level of dry bulk solids within the container. The columnar device and the sidewall openings therein can be provided in various shapes and configurations.

[0006] According to one aspect of the present invention, a bin level monitoring system is provided comprising: a columnar device adapted to be supported vertically within a bin, the columnar device having a closed lower end and at least one opening through a sidewall thereof for allowing dry bulk material within the bin to flow into and out of the columnar device; and a load cell associated with the columnar device, the load cell being arranged to measure a weight of the dry bulk material within the columnar device.

[0007] Numerous other objects of the present invention will be apparent to those skilled in this art from the following description wherein there is shown and described embodiments of the present invention, simply by way of illustration of some of the modes best suited to carry out the invention. As will be realized, the invention is capable of other different embodiments, and its several details are capable of modification in various obvious aspects without departing from the invention. Accordingly, the drawings and description should be regarded as illustrative in nature and not restrictive.

BRIEF DESCRIPTION OF DRAWINGS

[0008] The present invention will become more clearly appreciated as the disclosure of the present invention is made with reference to the accompanying drawings. In the drawings:

Fig. 1 is an elevation view of a dry bulk container, such as a feed bin, equipped with a conventional bin level monitoring system in which a flat circular plate or cone-shaped hat are supported within the bin.

Fig. 2 is a line graph showing the poor relationship between a load cell weight measurement and feed level height using a conventional bin level monitoring system in which a flat circular plate or a cone shaped hat are suspended within the bin.

Figs. 3(a) through 3(d) are perspective views of various columnar devices that can be used in the bin level monitoring system of the present invention to create a column of material to be weighed within a dry bulk container.

Fig. 4 is another elevation view of the dry bulk container equipped with the bin level monitoring system of the present invention.

Fig. 5 is a detail elevation view of the top of the dry bulk container showing the columnar device of the bin level monitoring system suspended via a load cell from the roof of the dry bulk container.

Fig. 6 is a line graph showing the excellent relationship between a load cell weight measurement and feed level height using the bin level monitoring system of the present invention.

Fig. 7 is another elevation view of the dry bulk container equipped with the bin level monitoring system of the present invention, which illustrates three feed positions that occur during the emptying of feed from the bin.

DETAILED DESCRIPTION OF THE INVENTION

[0009] A bin level monitoring system according to the present invention will now be described with reference to Figs. 1 to 7 of the accompanying drawings.

[0010] The present invention provides a simple and low-cost method and device to measure and monitor the level of dry bulk solids in a bin, thereby solving the problems with the prior art systems described above.

[0011] The origin of the present invention is in understanding the inherent flow characteristics of dry bulk materials that are stored and removed from any type of dry bulk storage container 10, such as a silo, bin, or other storage structure (see Fig. 1). The internal flow characteristics of dry bulk materials can be determined by placing a flat circular plate 11 mounted on a load cell 12 at the bottom of the dry bulk storage container 10 near the outlet 13. Theoretically, the flat circular plate 11 should measure the weight of a cylindrical column 14 of dry bulk material lying directly on top of the plate 11. However, the actual geometry of the dry bulk storage container 10, the dry bulk material particulate size and shape, the moisture content of the dry bulk material, and the dry bulk material friction factor (angle of repose) all effect this measurement when the dry bulk material begins to flow.

[0012] Testing of the above described configuration reveals that as dry bulk material is removed from the storage container 10, the weight measurement recorded by the load cell becomes steady (as shown in Fig. 2 for feed level heights between approximately 36 inches and 102 inches). The steady weight measurement is maintained until the dry bulk material level reaches a height (approximately 36 inches in Fig. 2), which is consistent with the material's angle of repose and diameter of the flat circular plate 11. The weight measurement at this point will begin to decrease as material is removed until the only material remaining is a cone shaped pile lying on the flat circular plate 11. Placing a cone shaped hat (not shown) on top of the flat circular plate 11 demonstrates the same weight to material level characteristics, except the cone shaped pile of dry bulk material is removed. Thus, the configuration of a

circular plate 11 or a cone-shaped hat mounted on a load cell 12 near the outlet 13 of a container 10 was determined to provide a poor relationship between the feed level height and the load cell weight measurement.

[0013] These tests indicate that as dry bulk materials flow through a dry bulk storage container, such as a silo, bin, or other storage structure, the internal flow forces of the material equilibrate to a certain level dependent upon the storage structure geometry, particulate size and shape, moisture content, and angle of repose. The resulting internal forces are equalized to a level that allows the feed to cave off and flow down through the storage structure towards the outlet.

[0014] The present invention removes and/or minimizes these variables by constraining a portion of the dry bulk material in a columnar device 20 that creates a column of material that can be weighed without being influenced by the outside parameters described previously. The columnar device 20 can have various shapes and configurations, such as the columnar devices 20a-20e illustrated in Figs. 3(a) to 3(e). For example, the columnar device 20 can have a rectangular cross section, as shown for columnar devices 20a and 20c in Figs. 3(a) and 3(c), or a circular cross section, as shown for columnar devices 20b, 20d and 20e in Figs. 3(b), 3(d) and 3(e). The columnar device 20 will also have at least one opening 21 through a sidewall 22 thereof for allowing bulk material within the container 10 to flow into and out of the columnar device 20, and a closed lower end 23. The sidewall openings 21 allow dry bulk material to enter and exit the columnar device as material levels change.

[0015] Figs. 3(a) and 3(b) illustrate columnar devices 20a, 20b in which openings 21a, 21b extend longitudinally along a length of the device on opposite sides of the device. For example, the openings 21a can be formed at the corners of a columnar device 20a with a rectangular cross section, as shown in Fig. 3(a), or the openings 21b can be formed in opposite sides of a columnar device 20b with a circular cross section, as shown in Fig. 3(b).

[0016] Fig. 3(c) illustrates a columnar device 20c having a rectangular cross section with a plurality of rectangular openings 21c through sidewalls 22c on opposite sides of the columnar device 20c. The openings 21c in this embodiment are spaced along a length of the columnar device 20c.

[0017] Fig. 3(d) illustrates a columnar device 20d having a circular cross section with a plurality of circular openings 21d through the sidewall 22d on opposite sides of the columnar device 20d. The openings 21d in this embodiment are spaced along a length of the columnar device 20d. However, testing of the use of circular openings 21d placed along the pipe shows that there may be a hysteresis that occurs during the filling and emptying process, which may interfere with the weight measurements with this embodiment.

[0018] Fig. 3(e) illustrates a columnar device 20e having a circular cross section with a plurality of rectangular openings 21e through the sidewall 22e on opposite sides of the columnar device 20e. The rectangular openings 21e in this embodiment are spaced along a length of the

columnar device 20e. The rectangular openings 21e are perpendicular to the axis of the columnar device 20e and have a length that extends to the tangential edges of the pipe, and a height that is approximately one-half of the length. This configuration allows proper dry bulk material flow into and from the inner volume of the columnar device 20e without obstruction. The center-to-center spacing of the rectangular openings 21e is approximately twice the rectangle height. Testing of the columnar device 20e with rectangular openings 21e shown in Fig. 3(e) resulted in more consistent measurements when dry bulk material was added or removed from the storage structure, as compared to the embodiment with circular openings 21d shown in Fig. 3(d).

[0019] Other shapes and configurations for the columnar device 20 and sidewall openings 21 can also be used, as long as a substantially isolated column of dry bulk material is created and the dry bulk material is allowed to flow into and out of the columnar device 20 when material is respectively added or removed from the dry bulk storage container 10. The columnar device 20 must also have a closed lower end 23, such as a bottom cap, to prevent free flow of dry bulk material through the device 20.

[0020] The columnar device 20 can be assembled from linear subsections 120, as shown in Fig. 4, so that the final deployed device matches the total depth of a storage structure of any height. The system can also be combined as two or more level monitors connected together to sample and report depths as an average of a number of locally variable depths in a storage container 10. The system can also be combined in a triangular array to measure material level in three directions within a storage container and to measure a wider range of material levels for better accuracy.

[0021] One embodiment of the columnar device 20 will be a standard plastic pipe with holes or openings placed perpendicular to the pipe axis through the sidewalls of the pipe. A standard cap 23 can be used to close off the bottom end of the pipe. This is a cost effective solution to creating a device that allows dry bulk material to flow into the center of the pipe and out of the pipe as the storage container 10 is filled or emptied, respectively.

[0022] The diameter of the columnar device can be anywhere between 1% to 75% of the diameter or maximum wall-to-wall distance of the storage container 10. The openings 21 that are placed into the columnar device sidewalls 22 can be any shape and have a cross-sectional opening area of 5.0% to 5000% of the internal cross-sectional area of the columnar device 20. These openings 21 are placed along the sidewalls 22 in such spacing to allow the dry bulk material to enter and exit the internal cross-sectional area without obstruction.

[0023] The columnar device 20 can be supported from a load cell, either tension or compression, at the top or bottom of the device 20. For example, the device 20 can be hung from a tension load cell 25, as shown in Figs. 4 and 5, so that the load cell 25 is positioned outside of the dry bulk material, easily accessible for service from the fill access opening 26 of the storage container 10, and will be positioned close to any means of communicating the weight signal to the main interface computer or display. The communication means can be

achieved by wireless communication, hard wiring, or other techniques that enable the weight signal to be transmitted to the user.

[0024] Testing of the invention shows that there is a linear characteristic between the feed level in the storage container 10 and the weight measured by the load cell 25, as illustrated in Fig. 6. The testing demonstrates that there is good correlation of the data when feed is loaded and unloaded from the storage container 10. The invention removes the outside influences owing to the dry bulk material flow conditions, and provides an inexpensive means of correlating the weight of material inside of the columnar device 20 to the height level of material inside the storage container 10.

[0025] The dry bulk storage container 10, such as a feed bin in this explanation, is positioned in a location such that the dry bulk material contained inside can be transferred to the location where it will be used. This transferring of the dry bulk material is typically done by using a mechanical auger, pneumatic flow, or cable type conveying system 27. The level measuring system of the present invention can use a columnar device 20 having multiple sections 120 attached end-to-end to accommodate the height of the storage container 10. The columnar device 20 has a lower cap 23 that prevents the dry bulk material from exiting the center of the columnar device 20 prematurely during removal of the dry bulk material from the dry bulk material storage container 10. The lower cap 23 keeps the dry bulk material inside of the columnar device 20 until the material exits naturally through the openings 21 in the sidewalls 22 of the columnar device 20 as the material is removed from the dry bulk material storage container 10. The columnar device 20 is suspended by a load cell 25 that measures the weight of the columnar device 20 within the system throughout the entire process of filling and emptying of the dry bulk material. The load cell 25 is connected to a transmitter that sends the load cell's electronic information to a receiver that converts the information into something useful for the manager, operator, or producer. The load cell 25 is suspended by a hanging bracket 28 that is fastened to the top access opening 26 of the bulk storage container 10. Fastening the hanging bracket 28 at this location allows for the columnar device 20 to be mainly located in the center of the material flow, which will result in a better measurement of the material height within the container 10. The columnar device 20 can be mounted in other locations as needed.

IMPLEMENTATION OF INVENTION

[0026] The system of measuring a level of dry bulk materials in a container 10 according to the present invention can be implemented as follows. The container 10 can be, for example, a round cylindrical storage bin which is typically used in animal production facilities. The columnar device 20 can be a cylindrical pipe with a series of openings 21 spaced along the length of the pipe, which extend through the pipe sidewalls 22 perpendicular to the pipe axis, as described above. The dry bulk storage container 10 and the columnar device 20 can also have other configurations and geometries, as described above. The concept is the same with the other configurations and geometries, but the placement of the columnar device 20 and

numerical calculations may differ slightly.

[0027] The columnar device 20 is installed into the feed bin 10 by connecting the columnar device 20 to a tension load cell 25 that is suspended through the top access opening 26 on the feed bin 10. This placement allows the columnar device 20 to be located in the center of the feed bin 10 and directly above the feed bin outlet 13. The overall length of the columnar device 20 should be such that it extends from the feed bin top opening 26 down to approximately 1-foot (0.3 m) above the feed bin outlet 13. The buffer distance between the lower end of the columnar device 20 and the feed bin outlet 13 protects the columnar device 20 from any interference or agitation created by the auger 27 when feed is removed.

[0028] The final weight of the columnar device 20 including its closed lower end 23, without any feed placed in the feed bin 10, is measured and will be the tare weight of the level measuring system.

[0029] When the level measuring system is installed and properly configured for the feed bin 10, the type of dry bulk material or feed to be used is weighed to determine an average bulk density. This can be achieved with a measuring cup and scale using known techniques.

[0030] The static friction factor or static angle of repose of the feed can be determined by pouring a fixed amount of feed onto a flat surface and measuring the angle of repose of the pile. The static angle of repose is an approximate measurement and will vary throughout a sampling of feed. Therefore, multiple tests should be performed and the results averaged to establish a final static angle of repose value for the specific feed or dry bulk material being measured. The measured average static angle of repose value will be used to calculate the volume of feed in the bin when the feed begins to flow through the center of the storage bin.

[0031] The internal volume of the columnar device 20 is calculated and multiplied by the feed density to determine the weight of feed contained in the columnar device 20 at full capacity. The weight of feed contained in the columnar device 20 is added to the columnar device tare weight to determine the total weight measurement when the feed bin is filled to maximum capacity.

[0032] The total volume of the dry bulk storage structure or feed bin can be calculated using the storage structure geometry. When the feed bin 10 is filled to capacity, the columnar device 20 will fill completely with feed. However, the load cell 25 will likely measure a weight in excess of the maximum weight calculated by using the feed density and volume inside of the columnar device 20 due to the "packing" of the feed that occurs during the bin filling process. The excess weight value will decrease to a value closer to the calculated total weight when feed begins to be removed from the bin 10 and the columnar device 20 is allowed to equilibrate to the newly filled bin. If the measured weight value exceeds the maximum calculated weight value, then the maximum calculated value will be used until the columnar device equilibrates to the bin.

[0033] The load cell 25 will communicate with a computer programmed with User Interface

Software and an algorithm that performs calculations for correlating measured weights of the columnar device 20 with the level of material in the feed bin 10. The calculated level of material in the feed bin 10 can be displayed on a graphic display device associated with the computer or transmitted to other control systems or information gathering systems, such as an RFID (radio frequency identification) reader or the like. The communications between the level measuring system and the computer interface will continue on a periodic time frame set by the user.

[0034] The columnar device 20 will allow feed to flow out from the inside of the column as feed is removed from the feed bin 10. As this feed is removed from the bin, the level of feed inside of the columnar device 20 will decrease causing the measured load cell weight of the level measuring system to decrease.

[0035] The level of feed in the bin 10 along with the geometry of the bin can be used to determine the volume of feed remaining in the feed bin. The calculations performed by the computer algorithm take into account three different feed level positions that occur during the emptying of feed from the bin 10, as illustrated in Fig. 7. As feed is removed from the bin 10, an inverted empty cone 30 will be created owing to the feed being removed from the bottom center 13 of the bin. This condition is the opposite of effect that occurs when feed is piled on a flat surface. The feed's angle of repose will define this inverted empty cone 30.

[0036] The first feed level position 31 shown in Fig. 7 is where the feed is beginning to flow from the bin 10, but the base of the inverted empty cone 30 has not yet contacted the walls 32 of the cylindrical portion of the bin. The second position 33 is where the base of the inverted cone 30 has contacted the cylindrical walls 32, but has not contacted the bottom edge of the cylindrical wall 32 where the bin begins to taper down to the outlet 13. The third position 34 is when the inverted empty cone 30 begins to enter into the tapered section of the bin. The feed level in the bin 10, the bin geometry, and the position of the feed in the bin can be used to calculate the volume of feed in the bin at any given moment.

[0037] The user will be able to establish several parameters within the User Interface Software associated with the computer that will allow for the transmitted information to be useful. These parameters can be, but are not limited to, the maximum columnar device weight, the minimum columnar device weight, corresponding feed densities for each bin, any scheduled notices for feed changes that may be required when the feed bin reaches a certain level, a maximum disappearance value, a minimum disappearance value, bin level order notification, and individual bin identification, size, dimensions, and location. These parameters will provide the user notice for any issues or changes occurring in the feed storage and handling process. An example would be that if a defective feed delivery system is present, the level monitoring device will record a value that will be constant with previous values indicating that feed is not being consumed. A notice will be presented to the user to inspect the equipment for proper operation. The quick notice for non-moving feed is important owing to the fact that for every day a production animal is off feed, it adds several days to the time it takes for the animal to reach a marketable weight.

[0038] The opposite condition of feed disappearing too rapidly is equally important for animal production facilities. The rapid disappearance of feed can indicate that a faulty feed delivery system is occurring and excess feed is being delivered to the feeding equipment. This condition could also indicate that the feed within the storage bin is "bridging" or failing to flow out of the bin causing the center section of the bin to become hollow and as a result no feed flows out of the bin.

[0039] The level information from the bins located on the farm coupled with any phase-feeding (changes in feed composition during the animal growing cycle) can be managed automatically through the software and the user defined feed delivery cycles that are established. The user would be able to review or list the entire feed inventory, the respective feed type in each bin, and a projected replenishment date for each bin. This capability will allow the user to have an immediate view of the animal production inputs and know when feed is needed or scheduled to arrive.

[0040] The present invention can also be used to coordinate feed delivery trucks with unloading the feed into the correct feed bin. This is a reoccurring problem on animal production facilities and can be solved by connecting the truck's contents to each feed bin via RFID located on the feed bins. The feed delivery truck would approach the targeted feed bin and the RFID reader installed on the delivery truck would read the bin RFID. If the two RFID's corresponded, the truck's contents would be unlocked and allowed to be unloaded into the correct feed bin. If the truck's contents are not unlocked, the truck driver would need to locate the correct bin. This interlocking relationship between the feed bins and the delivery trucks will ensure that the correct feed is delivered to the correct feed bin at the correct time.

REFERENCES CITED IN THE DESCRIPTION

This list of references cited by the applicant is for the reader's convenience only. It does not form part of the European patent document. Even though great care has been taken in compiling the references, errors or omissions cannot be excluded and the EPO disclaims all liability in this regard.

Patent documents cited in the description

- [US20030217596A](#) **[0003]**

PATENTKRAV

1. System til måling af et niveau af tørt løsgodsmateriale i en beholder (10), hvilket system omfatter:
 - 5 en søjleformet indretning (20) indrettet til at blive understøttet lodret i beholderen (10); og
 - en lastcelle (25) knyttet til den søjleformede indretning (20), hvilken lastcelle (25) er indrettet til at måle en vægt af det tørre løsgodsmateriale i den søjleformede indretning (20), **kendetegnet ved, at den søjleformede indretning har en lukket nedre**
10 **ende (23) og i det mindste én åbning (21) igennem en sidevæg (22) i denne, til at tillade at tørt løsgodsmateriale i beholderen strømmer ind i og ud af den søjleformede indretning.**
- 15 2. System ifølge krav 1, som yderligere omfatter en computerindretning til at korrelere den målte vægt af det tørre løsgodsmateriale med et niveau af materiale i beholderen (10).
3. System ifølge krav 1, hvor lastcellen (25) er en træklastcelle, og hvor den søjleformede indretning (20) er nedhængt fra lastcellen (25).
20
4. System ifølge krav 1, hvor den søjleformede indretning (20) er et cylindrisk element (20b, 20d, 20e).
- 25 5. System ifølge krav 1, hvor den søjleformede indretning (20) er et rørformet element med et rektangulært tværsnit (20a, 20c).
6. System ifølge krav 1, hvor den i det mindste ene åbning (21) omfatter adskillige åbninger (21c, 21d, 21e) igennem sidevæggen (22), anbragt i indbyrdes afstand langs en
30 længde af den søjleformede indretning (20).
7. System ifølge krav 6, hvor de adskillige åbninger er generelt rektangulært formede åbninger (21c, 21e), udformede i sidevæggen.

8. System ifølge krav 7, hvor de rektangulært formede åbninger (21e) har en længde i en horisontal retning og en højde i en vertikal retning, og hvor højden er mindre end længden.
- 5 9. System ifølge krav 8, hvor højden er omtrent halvdelen af længden.
- 10 10. System ifølge krav 8, hvor en midte til midte afstand imellem tilstødende åbninger (21e) er omtrent to gange den nævnte højde.
- 10 11. System ifølge krav 6, hvor de adskillige åbninger er generelt cirkulært formede åbninger (21d) udformede i sidevæggen.
12. System ifølge krav 6, hvor de adskillige åbninger (21c, 21d, 21e) er tilvejebragt på modstående sider af den søjleformede indretning.
- 15 13. System ifølge krav 1, hvor den i de mindste ene åbning (21a, 21b) strækker sig langs en længde af den søjleformede indretning.
- 20 14. System ifølge krav 1, hvor den i det mindste ene åbning omfatter første og anden langsgående åbninger (21a, 21b) på modstående sider af den søjleformede indretning, som strækker sig langs en længde af den søjleformede indretning.
- 25 15. System ifølge krav 1, hvor den søjleformede indretning omfatter adskillige lineære delsektioner (120), som er sammensat ende mod ende for at stemme overens med en højde af beholderen (10).
- 30 16. System ifølge krav 1, hvor den i det mindste ene åbning (21) har et totalt tværsnitsåbningsareal på 5% til 5000% af et indvendigt tværsnitsareal af den søjleformede indretning (20).
17. I kombination, en beholder (10) og et system i overensstemmelse med ethvert af de foregående krav i beholderen (10).
- 35 18. Kombination ifølge krav 17, hvor en diameter af den søjleformede indretning er imellem 1% og 75% af en diameter af beholderen (10).

19. Kombination ifølge krav 17, hvor den søjleformede indretning (20) er nedhængt fra en topende af beholderen (10) med den lukkede nedre ende (23) placeret over et udløb (13) ved en bundende af beholderen (10).

DRAWINGS

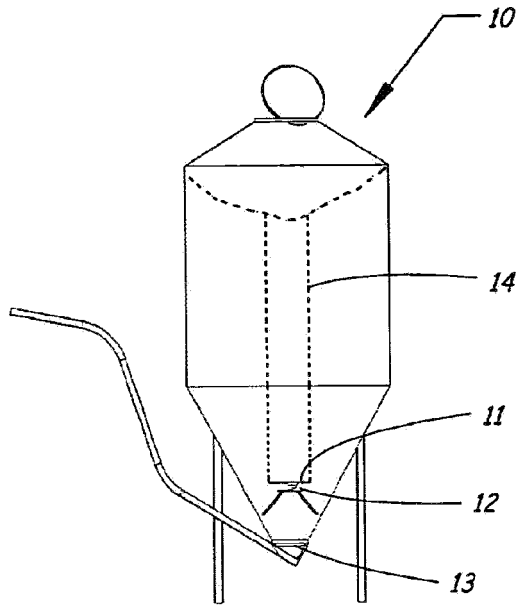

Fig. 1
(Prior Art)

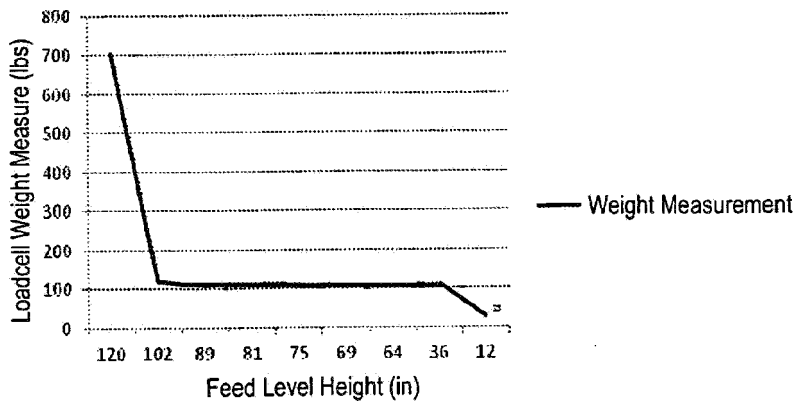

Fig. 2
(Prior Art)

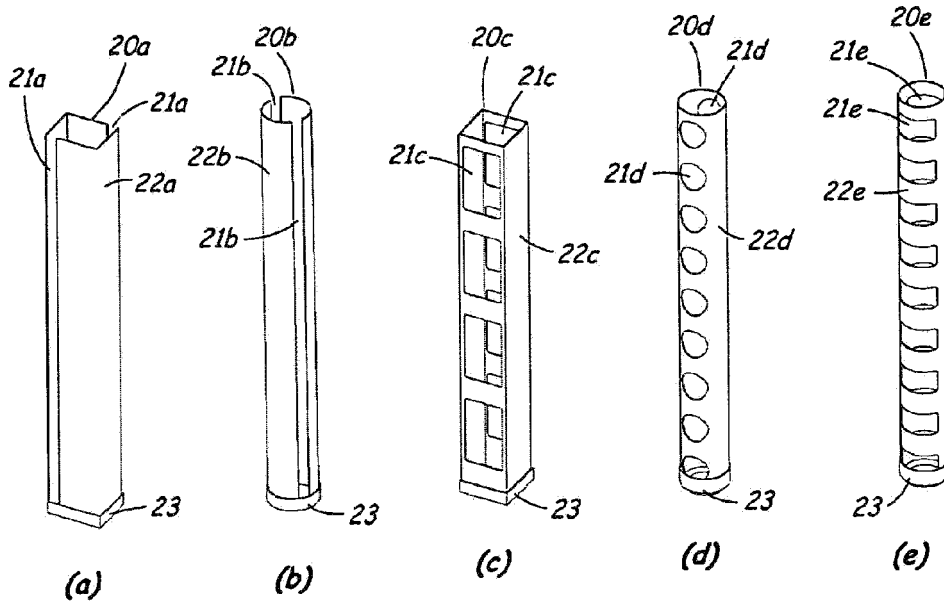

Fig. 3

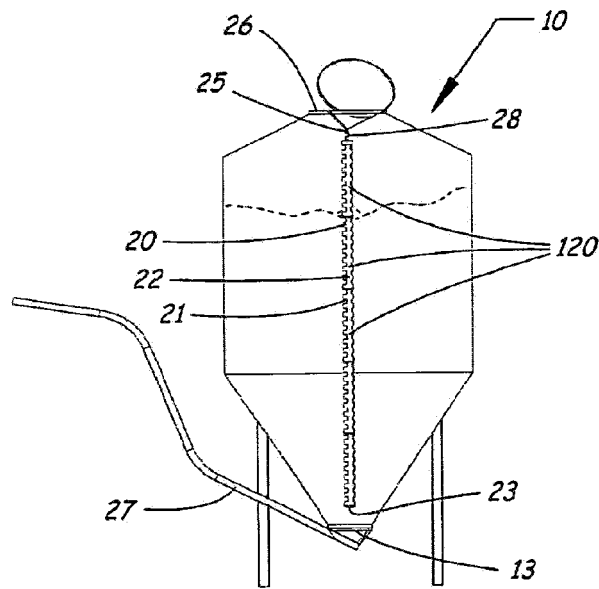

Fig. 4

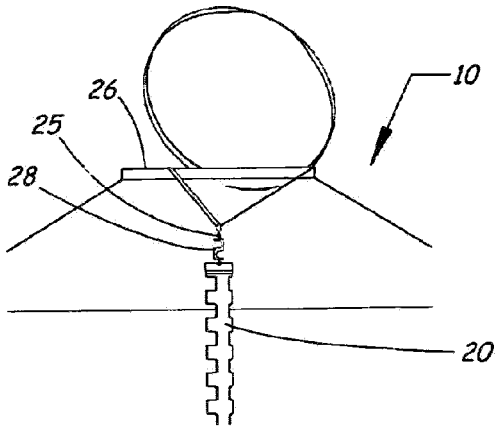

Fig. 5

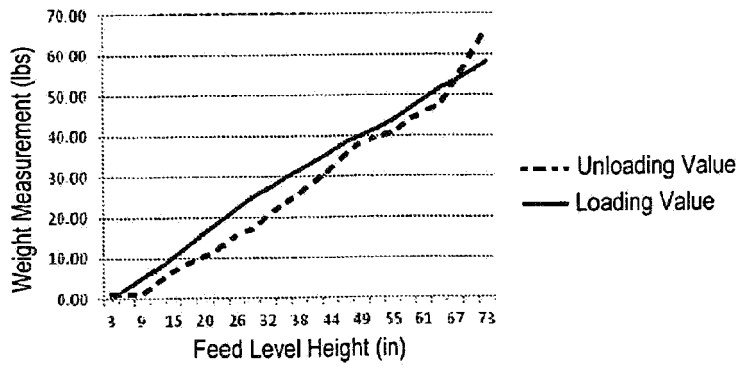

Fig. 6

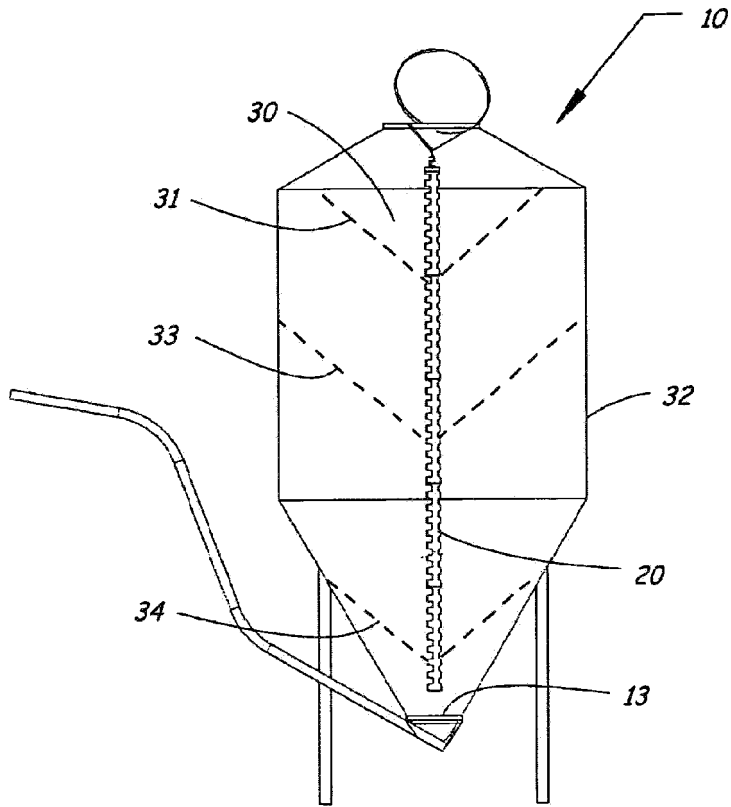

Fig. 7