

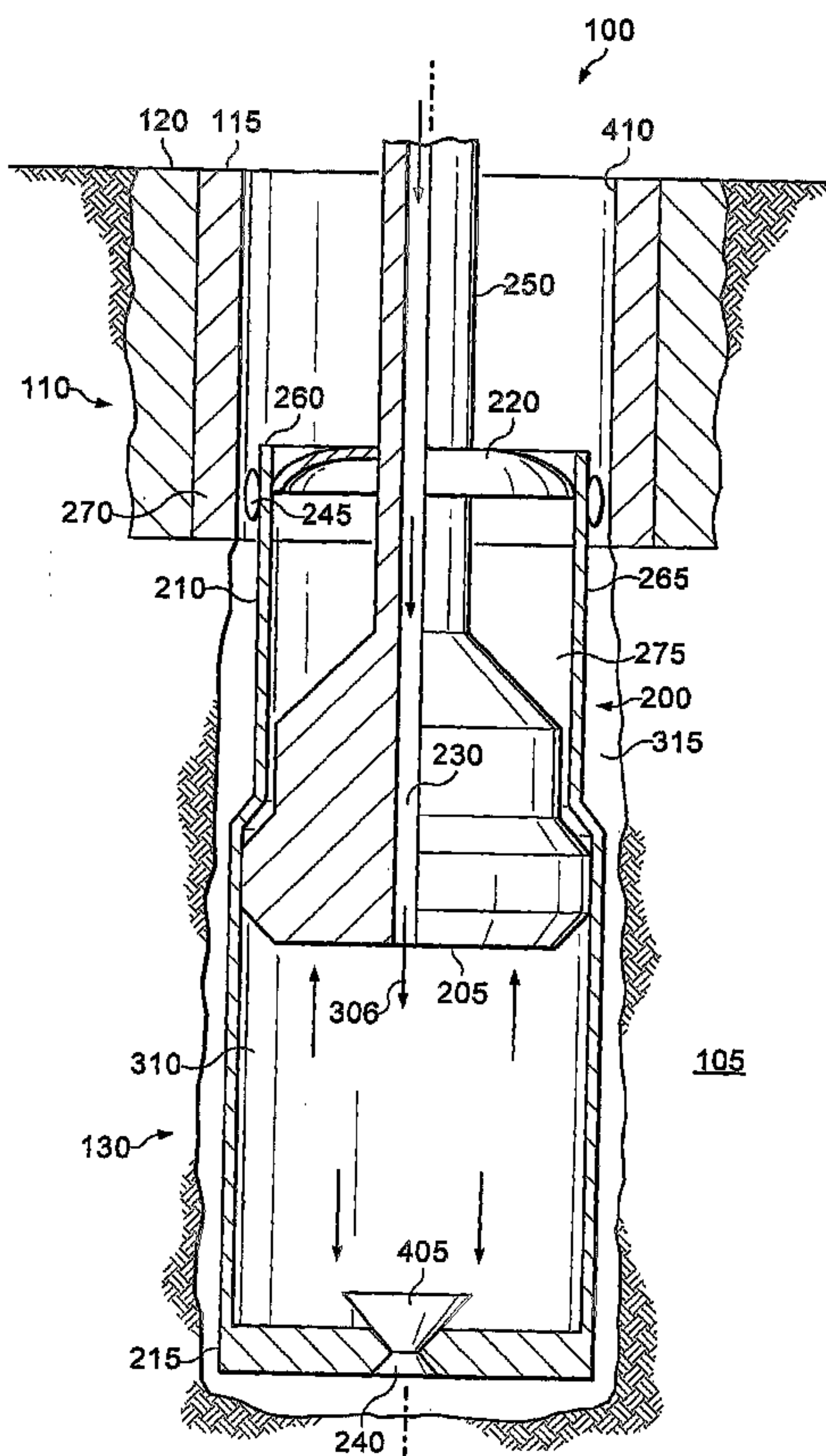

(86) Date de dépôt PCT/PCT Filing Date: 2003/08/18
 (87) Date publication PCT/PCT Publication Date: 2004/04/01
 (45) Date de délivrance/Issue Date: 2014/06/03
 (85) Entrée phase nationale/National Entry: 2005/03/14
 (86) N° demande PCT/PCT Application No.: US 2003/025675
 (87) N° publication PCT/PCT Publication No.: 2004/026500
 (30) Priorité/Priority: 2002/09/20 (US60/412,544)

(51) Cl.Int./Int.Cl. *E21B 23/00* (2006.01),
E21B 43/10 (2006.01)
 (72) Inventeurs/Inventors:
SHUSTER, MARK, US;
RING, LEV, US
 (73) Propriétaire/Owner:
ENVENTURE GLOBAL TECHNOLOGY, US
 (74) Agent: KIRBY EADES GALE BAKER

(54) Titre : MANDRIN D'EXTENSION AUTOLUBRIFIANT POUR ELEMENT TUBULAIRE EXTENSIBLE
 (54) Title: SELF-LUBRICATING EXPANSION MANDREL FOR EXPANDABLE TUBULAR



(57) **Abrégé/Abstract:**

A self-lubricating expansion mandrel includes a system for lubricating the interface between the self-lubricating expansion mandrel and a tubular member during the radial expansion of the tubular member.



Abstract

A self-lubricating expansion mandrel includes a system for lubricating the interface between the self-lubricating expansion mandrel and a tubular member during the radial expansion of the tubular member.

SELF-LUBRICATING EXPANSION MANDREL FOR EXPANDABLE TUBULAR

[002] The present application is related to the following: (1) U.S. patent application serial no. 09/454,139, issued as U.S. Patent No. 6,497,289, (2) U.S. patent application serial no. 09/510,913, issued as U.S. Patent No. 7,357,188, (3) U.S. patent application serial no. 09/502,350, issued as U.S. Patent No. 6,823,937, (4) U.S. Patent No. 6,328,113, (5) U.S. patent application serial no. 09/523,460, corresponding to WO 2001/037705, (6) U.S. patent application serial no. 09/512,895, issued as U.S. Patent No. 6,568,471, (7) U.S. patent application serial no. 09/511,941, issued as U.S. Patent No. 6,575,240, (8) U.S. patent application serial no. 09/588,946, issued as U.S. Patent No. 6,557,640, (9) U.S. patent application serial no. 09/559,122, issued as U.S. Patent No. 6,604,763, (10) PCT patent application serial no. PCT/US00/18635, published as WO 2001/004535, (11) U.S. provisional patent application serial no. 60/162,671, corresponding to U.S. Patent No. 7,048,067, (12) U.S. provisional patent application serial no. 60/159,082, corresponding to U.S. Patent No. 6,564,875, (13) U.S. provisional patent application serial no. 60/159,039, corresponding to U.S. Patent No. 6,695,012, (14) U.S. provisional patent application serial no. 60/159,033, corresponding to U.S. 2003/0107217, (15) U.S. provisional patent application serial no. 60/212,359, corresponding to WO 2001/098623, (16) U.S. provisional patent application serial no. 60/165,228, corresponding to WO 2001/026860, (17) U.S. provisional patent application serial no. 60/221,443, corresponding to WO 2002/010551, (18) U.S. provisional patent application serial no. 60/221,645, corresponding to U.S. Patent No. 7,100,684, (19) U.S. provisional patent application serial no. 60/233,638, corresponding to U.S. Patent No. 6,976,541, (20) U.S. provisional patent application serial no. 60/237,334, corresponding to WO 2002/029199, (21) U.S. provisional patent application serial no. 60/270,007, corresponding to U.S. Patent No. 7,195,064, (22) U.S. provisional patent application serial no. 60/262,434, corresponding to WO 2002/068792, (23) U.S. provisional patent application serial no. 60/259,486, corresponding to WO 2002/053867, (24) U.S. provisional patent application serial no. 60/303,740, corresponding to WO 2003/004819, (25) U.S. provisional patent application serial no. 60/313,453, corresponding to U.S. Patent No. 7,243,731, (26) U.S. provisional patent application serial no. 60/317,985 and U.S. provisional patent application serial no. 60/318,386, corresponding to WO 2003/023719, (27) U.S. utility patent application serial no. 09/969,922, issued as U.S. Patent No. 6,634,431, (28) U.S. utility patent application serial no. 10/016,467, issued as U.S. Patent No. 6,745,845, (29) U.S. provisional patent application serial no. 60/343,674, corresponding to U.S. Patent No. 7,290,605,

(30) U.S. provisional patent application serial no. 60/346,309, corresponding to U.S. Patent No. 8,047,281, (31) U.S. provisional patent application serial no. 60/372,048, corresponding to U.S. Patent No. 7,740,076, (32) U.S. provisional patent application serial no. 60/380,147, corresponding to WO 2003/093623, (33) U.S. provisional patent application serial no. 60/387,486, corresponding to U.S. Patent No. 7,398,832, (34) U.S. provisional patent application serial no. 60/387,961, corresponding to WO 2003/042486, WO 2003/042487 and WO 2003/106130, (35) U.S. provisional patent application serial no. 60/397,284, corresponding to U.S. 2006/0162937, (36) U.S. provisional patent application serial no. 60/398,061, corresponding to US 2006/0113085, (37) U.S. provisional patent application serial no. 60/405,610, corresponding to WO 2004/018824, (38) U.S. provisional patent application serial no. 60/405,394, corresponding to WO 2004/018823, (39) U.S. provisional patent application serial no. 60/412,542, corresponding to US 2006/0054330, (40) U.S. provisional patent application serial no. 60/412,487, corresponding to US 2006/0137877, (41) U.S. provisional patent application serial no. 60/412,488, corresponding to WO 2004/027200, (42) U.S. provisional patent application serial no. 60/412,653, corresponding to WO 2004/027392, (43) U.S. provisional patent application serial no. 60/412,544, corresponding to WO 2004/026500, (44) U.S. provisional patent application serial no. 60/412,196, corresponding to WO 2004/027786, and (45) U.S. provisional patent application serial no. 60/412,371, corresponding to WO 2004/023014.

Background of the Invention

[003] This invention relates generally to wellbore casings, and in particular to wellbore casings that are formed using expandable tubing.

[004] Conventionally, when a wellbore is created, a number of casings are installed in the borehole to prevent collapse of the borehole wall and to prevent undesired outflow of drilling fluid into the formation or inflow of fluid from the formation into the borehole. The borehole is drilled in intervals whereby a casing which is to be installed in a lower borehole interval is lowered through a previously installed casing of an upper borehole interval. As a consequence of this procedure the casing of the lower interval is of smaller diameter than the casing of the upper interval. Thus, the casings are in a nested arrangement with casing diameters decreasing in downward direction. Cement annuli are provided between the outer surfaces of the casings and the borehole wall to seal the casings from the borehole wall. As a consequence of this nested arrangement a relatively large borehole diameter is required at the upper part of the wellbore. Such a large borehole diameter involves increased costs due to heavy casing handling equipment, large drill bits and increased volumes of drilling fluid and

drill cuttings. Moreover, increased drilling rig time is involved due to required cement pumping, cement hardening, required equipment changes due to large variations in hole diameters drilled in the course of the well, and the large volume of cuttings drilled and removed.

[005] Conventionally, at the surface end of the wellbore, a wellhead is formed that typically includes a surface casing, a number of production and/or drilling spools, valving, and a Christmas tree. Typically the wellhead further includes a concentric arrangement of casings including a production casing and one or more intermediate casings. The casings are typically supported using load bearing slips positioned above the ground. The conventional design and construction of wellheads is expensive and complex.

[006] Conventionally, a wellbore casing cannot be formed during the drilling of a wellbore. Typically, the wellbore is drilled and then a wellbore casing is formed in the newly drilled section of the wellbore. This delays the completion of a well.

[007] The present invention is directed to overcoming one or more of the limitations of the existing procedures for forming wellbores and wellheads.

Summary of the Invention

[007a] Certain exemplary embodiments can provide a self-lubricating expansion mandrel for expanding a tubular member, comprising: a housing including a tapered outer surface; one or more grooves formed in the tapered outer surface; and solid lubricant retained in one or more of the grooves.

[007b] Certain exemplary embodiments can provide a self-lubricating expansion mandrel for expanding a tubular member, comprising: a housing including a tapered outer surface; one or more grooves formed in the tapered outer surface; and solid lubricant retained in a plurality of troughs formed in a textured pattern.

[007c] Certain exemplary embodiments can provide a self-lubricating expansion mandrel for expanding a tubular member, comprising: a housing including a tapered outer surface; one or more grooves formed in the tapered outer surface; and a grease supply chamber in the housing; a conduit from the grease supply chamber to one or more of the grooves; and means for forcing grease from the grease supply chamber through the conduit to one or more of the grooves.

[007d] Certain exemplary embodiments can provide a self-lubricating expansion mandrel for expanding a tubular member, comprising: a housing including a tapered outer surface; one or more grooves formed in the tapered outer surface; and solid lubricant retained in one or more of the grooves; wherein the grooves comprise circumferential grooves.

[007e] Certain exemplary embodiments can provide a self-lubricating expansion mandrel for expanding a tubular member, comprising: a housing including a tapered outer surface; one or more grooves formed in the tapered outer surface; and solid lubricant retained in one or more of the grooves; wherein the grooves comprise axial grooves.

[007f] Certain exemplary embodiments can provide a self-lubricating expansion mandrel for expanding a tubular member, comprising: a housing including a tapered outer surface; one or more grooves formed in the tapered outer surface; and solid lubricant retained in one or more of the grooves; wherein the grooves comprise a pattern of grooves with both an axial and a circumferential component.

[007g] Certain exemplary embodiments can provide a self-lubricating expansion mandrel for expanding a tubular member, comprising: a housing including a tapered outer surface; one or more grooves formed in the tapered outer surface; and solid lubricant retained in one or more of the grooves; wherein the pattern of grooves comprises a textured surface.

[007h] Certain exemplary embodiments can provide a self-lubricating expansion mandrel for expanding a tubular member, comprising: a housing including a tapered outer surface; one or more grooves formed in the tapered outer surface; and solid lubricant retained in one or more of the grooves; wherein the depth of the grooves is in a range of between about 1 and 4 microns.

[007i] Certain exemplary embodiments can provide a self-lubricating expansion mandrel for expanding a tubular member, comprising: a housing including a tapered outer surface; one or more grooves formed in the tapered outer surface; and solid lubricant retained in one or more of the grooves; wherein the depth of the grooves is in a range of between about 10 and 50 microns

[007j] Certain exemplary embodiments can provide a self-lubricating expansion mandrel for expanding a tubular member, comprising: a housing including a tapered outer surface; one or more grooves formed in the tapered outer surface; and solid lubricant retained in one or more of the grooves; wherein the solid lubricant retained in one or more of the grooves comprises a thermo-sprayed coating.

[007k] Certain exemplary embodiments can provide a self-lubricating expansion mandrel for expanding a tubular member, comprising: a housing including a tapered outer surface; one or more grooves formed in the tapered outer surface; and solid lubricant retained in one or more of the grooves; wherein the depth of the grooves is in a range of between about 50 and 150 microns.

[0071] Certain exemplary embodiments can provide a self-lubricating expansion device for expanding a tubular member, comprising: a housing including a tapered outer surface; one or more depressions formed in the tapered outer surface; and a lubricant supply chamber in the housing; a conduit from the lubricant supply chamber to one or more of the depressions; and means for forcing lubricant from the lubricant supply chamber through the conduit to one or more of the depressions.

[007m] Certain exemplary embodiments can provide a self-lubricating expansion device for expanding a tubular member, wherein the interface between the expansion device and the tubular member, during the expansion process, includes a leading edge portion and a trailing edge portion, comprising: a housing including a tapered outer surface; one or more first depressions formed in the leading edge portion of the tapered outer surface; and a lubricant supply chamber in the housing; a conduit from the lubricant supply chamber to one or more of the first depressions; means for forcing lubricant from the lubricant supply chamber through the conduit to one or more of the depressions; one or more second depressions formed in the trailing edge portion of the tapered outer surface; and a solid lubricant provided within one or more of the second depressions.

[008] According to one aspect of the present invention, a self-lubricating expansion mandrel for expanding a tubular member is provided that includes a housing having a tapered outer surface, one or more grooves formed in the tapered outer surface, and a solid lubricant deposited into one or more of the grooves.

[009] According to one aspect of the present invention, a self-lubricating expansion mandrel for expanding a tubular member is provided that includes a housing having a tapered outer surface, one or more grooves formed in the tapered outer surface, and a self-lubricating film deposited onto the surface and into one or more of the grooves.

[0010] According to one aspect of the present invention, a self-lubricating expansion mandrel for expanding a tubular member is provided that includes a housing having a tapered outer surface, one or more grooves formed in the tapered outer surface, and a fluoropolymer coating deposited onto the surface and into one or more of the grooves.

[0011] According to one aspect of the present invention, a self-lubricating expansion mandrel for expanding a tubular member is provided that includes a housing having a tapered outer surface, one or more grooves formed in the tapered outer surface, and a thermo-sprayed coating deposited onto the surface and into one or more of the grooves.

[0012] According to one aspect of the present invention, a self-lubricating expansion mandrel for expanding a tubular member is provided that includes a housing having a tapered outer surface, a pattern of grooves formed in the tapered outer surface, and a solid lubricant deposited into the pattern of grooves.

[0013] According to one aspect of the present invention, a self-lubricating expansion mandrel for expanding a tubular member is provided that includes a housing having a tapered outer surface, a pattern of grooves formed in the tapered outer surface, and a self-lubricating film deposited onto the surface and into the a pattern of grooves.

[0014] According to one aspect of the present invention, a self-lubricating expansion mandrel for expanding a tubular member is provided that includes a housing having a tapered outer surface, a pattern of grooves formed in the tapered outer surface, and a fluoropolymer coating deposited onto the surface and into the pattern of grooves.

[0015] According to one aspect of the present invention, a self-lubricating expansion mandrel for expanding a tubular member is provided that includes a housing having a tapered outer surface, a pattern of grooves formed in the tapered outer surface, and a thermo-sprayed coating deposited onto the surface and into the pattern of grooves.

[0016] According to one aspect of the present invention, a self-lubricating expansion mandrel for expanding a tubular member is provided that includes a housing having a tapered outer surface, a textured surface formed in the tapered outer surface, and a solid lubricant deposited into the textured surface.

[0017] According to one aspect of the present invention, a self-lubricating expansion mandrel for expanding a tubular member is provided that includes a housing having a tapered outer surface, a textured surface formed in the tapered outer surface, and a self-lubricating film deposited onto the textured surface.

[0018] According to one aspect of the present invention, a self-lubricating expansion mandrel for expanding a tubular member is provided that includes a housing having a tapered outer surface, a textured surface formed in the tapered outer surface, and a fluoropolymer coating deposited onto the textured surface.

[0019] According to one aspect of the present invention, a self-lubricating expansion mandrel for expanding a tubular member is provided that includes a housing having a tapered outer surface, a textured surface formed in the tapered outer surface, and a thermo-sprayed coating deposited onto the textured surface.

[0020] According to another aspect of the invention the grooves, pattern or textured surface comprises with troughs to having depths of between 1 and 4 microns deep and the thin film is deposited into the troughs.

[0021] According to another aspect of the invention the grooves, pattern or textured surface comprises troughs to having depths of between 10 and 50 microns deep and the flouropolymer coating is deposited into the troughs.

[0022] According to another aspect of the invention the grooves, pattern or textured surface comprises troughs to having depths of between 50 and 150 microns deep and the thermo-sprayed coating is deposited into the troughs.

[0023] According to another aspect of the present invention, a method of expanding a tubular member in a wellbore is provided that includes forcing a lubricating grease from inside the expansion mandrel to the interface between the tubular member and the mandrel while the tubular member is being expanded by the mandrel within the wellbore.

[0024] According to one aspect of the present invention, a self-lubricating expansion mandrel for expanding a tubular member is provided that includes a housing having a tapered outer surface one or more grooves formed in the tapered outer surface, and one or more grease flow passages connected through the housing to one or more of the grooves.

[0025] According to one aspect of the present invention, a self-lubricating expansion mandrel for expanding a tubular member is provided that includes a housing having a tapered outer surface one or more grooves formed in the tapered outer surface, and one or more grease flow passages connected through the housing to one or more of the grooves and means for forcing a lubricating grease through the grease flow passages into the grooves formed on the tapered outer surface of the mandrel.

[0026] According to another aspect of the present invention, a self-lubricating expansion mandrel for expanding a tubular member is provided that includes a housing having an outer tapered surface including, one or more circumferential grooves formed in the outer surface of the tapered first end, and one or more grease flow passages connected through the mandrel housing to the grooves, and means for forcing a lubricating grease through the grease flow passages into the one or more circumferential grooves formed on the surface of the mandrel.

[0027] According to another aspect of the present invention, a self-lubricating expansion mandrel for expanding a tubular member is provided that includes a housing including an outer surface having one or more axial grooves formed in the outer surface of the tapered middle, and one or more grease flow passages connected through the mandrel housing to the grooves, and means for forcing a lubricating grease through the grease flow passages into the one or more axial grooves formed on the surface of the mandrel.

[0028] According to another aspect of the present invention, a self-lubricating expansion mandrel for expanding a tubular member is provided that includes a housing having an outer surface including one or more grooves formed in the outer tapered surface and further having a textured pattern comprising axial and circumferential components, and one or more grease flow passages connected to the grooves, and means for forcing a lubricating grease through the grease flow passages into grooves formed on the surface of the mandrel.

Brief Description of the Drawings

[0029] FIG. 1 is a fragmentary cross-sectional view illustrating the placement of an embodiment of an apparatus for creating a casing within a new tubular member section of a well borehole, an expansion mandrel and the injection of a fluidic material into a new tubular section of the well borehole for hydraulically moving the expansion mandrel through and thereby expanding the tubular member.

[0030] FIG. 2 is a fragmentary cross-sectional view of one alternative embodiment of a self lubricating expansion mandrel having a horizontal or circumferential groove for retaining grease, a fluouopolymer, a thermo-sprayed coating, a thin self-lubricating film or another solid lubricant, according to certain aspects of the invention.

[0031] FIG. 3 is a fragmentary cross-sectional view of another alternative embodiment of a self-lubricating expansion mandrel according to certain aspects of the invention.

[0032] FIG. 4 is a fragmentary cross-sectional view of another alternative embodiment of a self-lubricating expansion mandrel according to certain aspects of the invention.

[0033] FIGS. 5A-E are examples of groove or texture patterns that may be used according to certain aspects of th present invention.

[0034] FIGS. 6A-E are examples of surface profiles that may be useful according to certain aspects of the present invention.

[0035] FIG. 7A-C is a schematic depiction a single exemplary trough or groove of a pattern or textured surface of a self-lubricating expansion mandrel subjected to a series of steps for: 7A forming the trough, 7B depositing a thin self-lubricating film, and 7C retaining the self-lubricating film in the trough for the self-lubricating expansion mandrel.

[0036] FIG. 8A-C is a schematic depiction a single exemplary trough or groove of a pattern or textured surface of a self-lubricating expansion mandrel subjected to a series of steps for: 8A forming the trough, 8B depositing a fluouopolymer coating, and 8C retaining the fluouopolymer coating in the trough for the self-lubricating expansion mandrel.

[0037] FIG. 9A-C is a schematic depiction a single exemplary trough or groove of a pattern or textured surface of a self-lubricating expansion mandrel subjected to a series of steps for: 9A forming the trough, 9B depositing a thermo-sprayed coating, and 9C retaining the thermo-sprayed coating in the trough for the self-lubricating expansion mandrel.

[0038] FIG. 10 is a fragmentary cross-sectional view of one alternative embodiment of a self lubricating expansion mandrel having a grease delivery mechanism, and a horizontal groove for receiving, retaining and providing grease to the surface of a self-lubricating expansion mandrel according to certain aspects of the invention.

[0039] FIG. 11 is a fragmentary cross-sectional view of one alternative embodiment of a self lubricating expansion mandrel having a grease delivery mechanism, and a groove pattern with circumferential and axial components for receiving, retaining and providing grease to the surface of a self-lubricating expansion mandrel according to certain aspects of the invention.

[0040] FIG. 12 is a fragmentary cross-sectional view of one alternative embodiment of a self lubricating expansion mandrel having a grease delivery mechanism, and a groove and a textured surface pattern for receiving, retaining and providing grease to the surface of a self-lubricating expansion mandrel according to certain aspects of the invention.

Detailed Description of the Illustrative Embodiments

[0041] A self-lubricating expansion mandrel is provided. In an exemplary implementation, the self-lubricating expansion mandrel is used in conjunction with one or more methods for expanding tubular members. In this manner, the expansion of a plurality of tubular members coupled to one another using the self-lubricating expansion mandrel may be optimized.

[0042] Alternative embodiments of a self-lubricating expansion mandrel is also provided to form a self-lubricating expansion mandrel. In illustrative implementations, the self-lubricating expansion mandrel includes one or more circumferential grooves, one or more axial grooves, both circumferential and axial grooves, one or more patterns of grooves having circumferential and axial components of length and width, and/or surface textures for holding and providing a supply of grease, solid lubricant, thermo-sprayed coatings, fluoropolymer coatings, and/or self-lubricating films to surface of the self-lubricating expansion mandrel and to the interface between the tapered outer surface of the self-lubricating expansion mandrel and a tubular member during the radial expansion process. In this manner, the frictional forces created during the radial expansion process are reduced which results in a reduction in the required operating pressures for radially expanding the tubular member. The depth of the grooves, patterns, or textured surface is selected to facilitate maintaining the supply of lubrication through a period of the expansion process depending in part upon the type of lubrication whether grease, solid lubricant, thermo-sprayed coating, fluoropolymer coating or thin self-lubricating film.

[0043] In several alternative embodiments, the apparatus and methods are used to form and/or repair wellbore casings, pipelines, and/or structural supports.

[0044] Referring initially to FIGS. 1-4, embodiments of improved apparatus and method using a self-lubricating expansion mandrel for forming a wellbore casing within a subterranean formation will now be described.

[0045] FIG. 1 is a fragmentary cross-sectional view illustrating the placement of an embodiment of an apparatus for creating a casing within a new tubular member section of a well borehole, an expansion mandrel and the injection of a fluidic material into a new tubular section of the well borehole for hydraulically moving the expansion mandrel through and thereby expanding the tubular member. As illustrated, a wellbore 100 is positioned in a subterranean formation 105. The wellbore 100 includes an existing cased section 110 having a tubular casing 115 and an annular outer layer of cement 120.

[0046] In order to extend the wellbore 100 into the subterranean formation 105, a drill string 125 is used in a well known manner to drill out material from the subterranean formation 105 to form a new section 130.

[0047] As illustrated, an apparatus 200 for forming a wellbore casing in a subterranean formation is then positioned in the new section 130 of the wellbore 100. The apparatus 200 includes an expansion mandrel 205, a tubular member 210, a shoe 215, a lower cup seal 220, an upper cup seal 225, a fluid passage 230, a fluid passage 235, a fluid passage 240, seals 245, and a support member 250.

[0048] The expansion mandrel 205 is coupled to and supported by the support member 250. The expansion mandrel 205 is preferably adapted to controllably expand in a radial direction. The expansion mandrel 205 may comprise any number of conventional commercially available expansion mandrels modified in accordance with the teachings of the present disclosure to form a self-lubricating expansion mandrel 205. In an illustrative embodiment, the expansion mandrel 205 comprises a hydraulic expansion tool as disclosed in U.S. Patent No. 5,348,095 modified in accordance with the teachings of the present disclosure.

[0049] The tubular member 210 is supported by the self-lubricating expansion mandrel 205. The tubular member 210 is expanded in the radial direction and extruded off of the self-lubricating expansion mandrel 205. The tubular member 210 may be fabricated from any number of conventional commercially available materials such as, for example, Oilfield Country Tubular Goods (OCTG), 13 chromium steel tubing/casing, or plastic tubing/casing. In a preferred embodiment, the tubular member 210 is fabricated from OCTG in order to maximize strength after expansion. The inner and outer diameters of the tubular member 210 may range, for example, from approximately 0.75 to 47 inches and 1.05 to 48 inches, respectively. In a preferred embodiment, the inner and outer diameters of the tubular member 210 range from about 3 to 15.5 inches and 3.5 to 16 inches, respectively in order to optimally provide minimal telescoping effect in the most commonly drilled wellbore sizes. The tubular member 210 preferably comprises a solid member.

[0050] In a preferred embodiment, the end portion 260 of the tubular member 210 is slotted, perforated, or otherwise modified to catch or slow down the mandrel 205 when it completes the extrusion of tubular member 210. In a preferred embodiment, the length of the tubular member 210 is limited to minimize the possibility of buckling. For typical tubular member 210 materials, the length of the tubular member 210 is preferably limited to between about 40 to 20,000 feet in length.

[0051] The shoe 215 is coupled to the self-lubricating expansion mandrel 205 and the tubular member 210. The shoe 215 includes fluid passage 240. The shoe 215 may comprise any number of conventional commercially available shoes such as, for example, Super Seal II float shoe, Super Seal II Down-Jet float shoe or a guide shoe with a sealing sleeve for a latch down plug modified in accordance with the teachings of the present disclosure. In a preferred embodiment, the shoe 215 comprises an aluminum down-jet guide shoe with a sealing sleeve for a latch-down plug available from Halliburton Energy Services in Dallas, TX, modified in accordance with the teachings of the present disclosure, in order to optimally guide the tubular member 210 in the wellbore, optimally provide an adequate seal between the interior and exterior diameters of the overlapping joint between the tubular members, and to optimally allow the complete drill out of the shoe and plug after the completion of the cementing and expansion operations.

[0052] The shoe 215 illustrated in Fig. 1, includes one or more through and side outlet ports in fluidic communication with the fluid passage 240. In this manner, the shoe 215 optimally injects hardenable fluidic sealing material into the region outside the shoe 215 and tubular member 210.

[0053] In the embodiments as depicted in FIGS. 2-4, the fluid passage 240 comprising an inlet geometry that can receive a dart and/or a ball sealing member. In this manner, the fluid passage 240 can be optimally sealed off by introducing a plug, dart and/or ball sealing elements into the fluid passage 230.

[0054] In the illustrative embodiment depicted, a lower cup seal 220 is coupled to and supported by a support member 250. The lower cup seal 220 prevents foreign materials from entering the interior region of the tubular member 210 adjacent to the self-lubricating expansion mandrel 205. The lower cup seal 220 may comprise any number of conventional commercially available cup seals such as, for example, TP cups, or Selective Injection Packer (SIP) cups modified in accordance with the teachings of the present disclosure. In a preferred embodiment, the lower cup seal 220 comprises a SIP cup seal, available from Halliburton Energy Services in Dallas, TX in order to optimally block foreign material and might also contain a body of lubricant adjacent to the expansion mandrel.

[0055] The upper cup seal 225 is coupled to and supported by the support member 250. The upper cup seal 225 prevents foreign materials from entering the interior region of the tubular member 210. The upper cup seal 225 may comprise any number of conventional commercially available cup seals such as, for example, TP cups or SIP cups modified in accordance with the teachings of the present disclosure. In a preferred embodiment, the upper cup seal 225 comprises a SIP cup, available from Halliburton Energy Services in Dallas, TX in order to optimally block the entry of foreign materials and contain a body of lubricant.

[0056] The fluid passage 230 permits fluidic materials to be transported to and from the interior region of the tubular member 210 below the self-lubricating expansion mandrel 205. The fluid passage 230 is coupled to and positioned within the support member 250 and the self-lubricating expansion mandrel 205. The fluid passage 230 preferably extends from a position adjacent to the surface to the bottom of the self-lubricating expansion mandrel 205. The fluid passage 230 is preferably positioned along a centerline of the apparatus 200.

[0057] The fluid passage 240 permits fluidic materials to be transported to and from the region exterior to the tubular member 210 and shoe 215. The fluid passage 240 is coupled to and positioned within the shoe 215 in fluidic communication with the interior region of the tubular member 210 below the self-lubricating expansion mandrel 205. The fluid passage 240 preferably has a cross-sectional shape that permits a plug, or other similar device, to be placed in fluid passage 240 to thereby block further passage of fluidic materials. In this manner, the interior region of the tubular member 210 below the self-lubricating expansion mandrel 205 can be fluidically isolated from the region exterior to the tubular member 210. This permits the interior region of the tubular member 210 below the self-lubricating expansion mandrel 205 to be pressurized. The fluid passage 240 is preferably positioned substantially along the centerline of the apparatus 200.

[0058] The fluid passage 240 is preferably selected to convey materials such as cement, drilling mud or epoxies at flow rates and pressures ranging from about 0 to 3,000 gallons/minute and 0 to 9,000 psi in

order to optimally fill the annular region between the self-lubricating expansion mandrel and the tubular section so that the tapered or expansion conical surface of the mandrel is forced against the inside diameter of the tubular section to thereby expand the tubular member to the size of the maximum diameter of the self-lubricating expansion mandrel.

[0059] Pumping the fluid hydraulically forces the exterior tapered or conical surface of the self-lubricating expansion mandrel into direct sliding contact with the ID of the tubular member as the material of the tubular member is plastically deformed beyond the elastic limit of the tubular member thereby permanently deforming the tubular member to a larger diameter. significant pressure and heat are generated at the interface between the tubular member and the surface of the self-lubricating expansion mandrel. The use of a self-lubricating expansion mandrel reduces the friction and facilitates the prevention of galling as a result of instantaneous surface to surface "welding" and subsequent relative movement that can occur when two metals slide under high pressure without lubrication.

[0060] The self-lubricating expansion mandrel provides grooves or troughs in a textured surface that are below the surface to surface interface contact area of the expansion mandrel. these troughs or grooves are filled with grease or with materials that are solid under normal heat and pressure conditions and that act as lubricants under high temperature and pressure conditions. Being solid or having a very high viscosity such as with grease, allows the lubricant to be retained within the groove or trough the relative motion and extreme pressure between the mandrel and the tubular member cause small quantities of the material to move between the interface contacting surfaces to act as a lubricant. The grooves or troughs act as relative low pressure areas on the interface surface so that a substantial quantity of the lubricant continues to be retained during the expansion. Only small quantities are required to avoid metal to metal contact at the solid lubricant until interface.

[0061] The self-lubricating expansion mandrel 205 preferably has a substantially annular cross section. The outside diameter of the self-lubricating expansion mandrel 205 is preferably tapered from a minimum diameter to a maximum diameter to provide a cone shape expansion surface. The wall thickness of the self-lubricating expansion mandrel 205 may range, for example, from about 0.125 to 3 inches. In a preferred embodiment, the wall thickness of the self-lubricating expansion mandrel 205 ranges from about 0.25 to 0.75 inches in order to optimally provide adequate compressive strength with minimal material. The maximum and minimum outside diameters of the expansion cone 928 may range, for example, from about 1 to 47 inches. In a preferred embodiment, the maximum and minimum outside diameters of the self-lubricating expansion mandrel range from about 3.5 to 19 in order to optimally provide expansion of generally available oilfield tubular members.

[0062] The self-lubricating expansion mandrel 205 may be fabricated from any number of conventional commercially available materials such as, for example, ceramic, tool steel, titanium or low alloy steel. In a preferred embodiment, the self-lubricating expansion mandrel 205 is fabricated from tool steel in order to optimally provide high strength and abrasion resistance. The surface hardness of the outer surface of the

self-lubricating expansion mandrel may range, for example, from about 50 Rockwell C to 70 Rockwell C.

In a preferred embodiment, the surface hardness of the outer surface of self-lubricating expansion mandrel 205 ranges from about 58 Rockwell C to 62 Rockwell C in order to optimally provide high yield strength. In a preferred embodiment, the self-lubricating expansion mandrel is heat treated to optimally provide a hard outer surface and a resilient interior body in order to optimally provide abrasion resistance and fracture toughness.

[0063] FIG. 2 is a fragmentary cross-sectional view of one alternative embodiment of a self lubricating expansion mandrel having one or more circumferential grooves 12 for retaining and distributing grease, or another solid lubricant, according to certain aspects of the invention. Large and deep grooves are desirable for retaining sufficient quantities of grease. Progressively smaller and more shallow grooves are desirable for retaining a fluoropolymer material, a thermo-sprayed coating, and a thin self-lubricating film.

[0064] FIG. 3 is a fragmentary cross-sectional view of another alternative embodiment of a self-lubricating expansion mandrel having one or more axially aligned grooves 14 for retaining and distributing grease, or another solid lubricant, according to certain aspects of the invention. Large and deep grooves are desirable for retaining sufficient quantities of grease. Progressively smaller and more shallow grooves are desirable for retaining a fluoropolymer material, a thermo-sprayed coating, and a thin self-lubricating film according to certain

[0065] FIG. 4 is a fragmentary cross-sectional view of another alternative embodiment of a self-lubricating expansion mandrel having a pattern of grooves 16 with circumferential and axial components for retaining and distributing grease, or another solid lubricant, according to certain aspects of the invention. Large and deep grooves are desirable for retaining sufficient quantities of grease. Progressively smaller and more shallow grooves are desirable for retaining a fluoropolymer material, a thermo-sprayed coating, and a thin self-lubricating film according to certain aspects of the invention.

[0066] FIGS. 5A-E are examples of groove or texture patterns 16A-16E that may be used according to certain aspects of the present invention.

[0067] FIGS. 6A and 6B are examples of surface profiles 18A and 18B that may be useful according to certain aspects of the present invention.

[0068] Fig 6A depicts a surface profile that comprises large and small troughs 20 and 22, respectively, that may be regularly repeated to provide one of the patterns 16A-16E as in FIGS 5A-E or other patterns.

[0069] Fig. 6B depicts a surface profile that comprises generally regular or uniform peaks 24 and troughs 26. The troughs 26 and peaks 24 are depicted as relatively equal in size and number, however it will be understood that many of the patterns 16 of grooves or troughs contemplated will provide significantly more contact surface area 28 than the total of all area covered by the troughs. The contact pressure is not significantly increased by the removal of metal contact area through the formation of grooves, a pattern or a textured surface.

[0070] FIGS. 7A-C schematically depict the formation of a single exemplary trough 30 or groove of a pattern 16 or textured surface comprising a plurality of such grooves or troughs to form the tapered outer expansion surface 32 of a self-lubricating expansion mandrel 205 where the solid lubrication is provided by the deposition of a thin self-lubricating film 34. Such films may comprise Balinic C or other diamond-like-coating (DLC) preferably deposited as a tightly bonding surface coating having a thicknesses of less than about 5 microns. The grooves or troughs 30 of FIGS 7A-C are preferably in the range of from about 1 micron to 4 microns deep 36 and from about 1 micron to about 4 microns wide 38 to facilitate holding a quantity of the deposited thin self-lubricating film 34 within the grooves or troughs 30. A portion will be retained even with and below the metal contacting tapered surface 32. FIG. 7A depicts forming the trough 30 into the tapered surface 32. FIG. 7B depicts depositing a thin self-lubricating film 34 between about 1 and 4 microns thick 35 and in an exemplary embodiment are of even thickness with or slightly thicker than the trough 30 is deep 36. FIG. 7C depicts a quantity of the self-lubricating film 34 retained in the trough 30, after final machining of the tapered surface 32, for providing both the metal contacting areas 32 and a retained quantity of self-lubricating film material 34. During expansion of a tubular member 210, the lubrication is provided from the trough 30 to the tapered expansion surface 32 of the self-lubricating expansion mandrel 205.

[0071] FIG. 8A-C schematically depict the formation of a single exemplary trough 40 or groove of a pattern 16 or textured surface comprising a plurality of such grooves or troughs form into a tapered expansion surface 42 of a self-lubricating expansion mandrel 205 where the solid lubrication is provided by the deposition of a fluoropolymer coating 44. Fluoropolymer materials such as PTFE, molybdenum disulfide, or graphite, that are solid at ambient temperatures and soft relative to the metal tapered surface 42 of the self-lubricating expansion mandrel 205, may be used for this purpose. The deposit thickness 45 of such coatings 44 may be in the range of from 10 to 50 microns and in an exemplary embodiment are at least as thick as the grooves or troughs are deep 46. The grooves or troughs 40 of FIGS 8A-C are preferably in the range of from about 10 micron to 50 microns deep 46 and from about 10 micron to about 50 microns wide 48 and thus designed for the deposition and retention of a fluoropolymer coating 44. FIG. 8A depicts forming the trough 40 into the tapered surface 42. FIG. 8B depicts depositing a fluoropolymer coating 44 between about 10 and 50 microns thick 45 and in an exemplary embodiment are at least as thick or thicker than the trough is deep 46. FIG. 8C depicts a quantity the fluoropolymer coating 44 retained in the trough 40, after final machining of the tapered surface 42, for providing both the metal contacting areas 42 and a retained quantity of fluoropolymer coating material 44. During expansion of a tubular member 210, the lubrication is provided from the trough 40 to the tapered expansion surface 42 of the self-lubricating expansion mandrel 205.

[0072] FIG. 9A-C schematically depict the formation of a single exemplary trough 50 or groove of a pattern 16 or textured surface comprising a plurality of such grooves or troughs formed into a tapered expansion surface 52 of a self-lubricating expansion mandrel 205 where the solid lubrication is provided

by the deposition of a fluoropolymer coating 54. The grooves or troughs 50 of FIGS. 9A-C are, in an exemplary embodiment, in the range of from about 50 micron to 150 microns deep 56 and from about 50 micron to about 150 microns wide 58 thus designed for the deposition and retention of a thermo-sprayed coating 54. FIG. 9A depict forming the trough 50 into the tapered surface 52. FIG. 9B depicts depositing a thermo-sprayed coating (as by detonation spray) between about 50 and 150 microns thick and, in an exemplary embodiment, are at least as thick or thicker than the trough is deep. FIG. 9C depicts a quantity the thermo-sprayed coating 54 retained in the trough 50, after final machining of the tapered surface 52, for providing both the metal contacting areas 52 and a retained quantity of the thermo-sprayed coating material 54. During expansion of a tubular member 210, the lubrication is provided from the trough 50 or groove to the tapered expansion surface 52 of the self-lubricating expansion mandrel 205.

[0073] FIG. 10 is a fragmentary cross-sectional view of one alternative embodiment of a self lubricating expansion mandrel having a grease delivery mechanism, and a circumferential groove 12 for receiving, retaining and providing grease 61 to the surface 62 of a self-lubricating expansion mandrel 205 according to certain aspects of the invention. The grease delivery mechanism 60 comprises a grease supply chamber 64 within the housing of the self lubricating expansion mandrel and one or more grease passages 68 from the grease supply chamber 64 to the outer tapered surface 62 of the self lubricating expansion mandrel 205. Pressure within passage 230 may communicate with the grease supply chamber 64 to force grease into the grooves 12 when the self lubricating expansion mandrel 205 is acting, by the hydraulic forces as described with regard to Fig 1 above, to expand the tubular member 210.

[0074] FIG. 11 is a fragmentary cross-sectional view of one alternative embodiment of a self lubricating expansion mandrel 205 having a grease delivery mechanism 70, and a groove pattern 16 with circumferential and axial components for receiving, retaining and providing grease to the surface 72 of a self-lubricating expansion mandrel 205 according to certain aspects of the invention. The grease delivery mechanism 70 comprises a grease supply chamber 74 within the housing of the self lubricating expansion mandrel and one or more grease passages 78 from the grease supply chamber 74 to the pattern of grooves 16 formed in the outer tapered surface 72 of the self lubricating expansion mandrel 205. In this alternative embodiment, pressure 86 may be separately supplied through a separate pressure line 80 to actuate a mechanism 84 such as a piston within the grease supply chamber 74 and to force grease through the one or more grease passages 78 into the grooves 16. The pressure 84 in the separate pressure line may be controlled to increase or decrease the amount of grease 71 delivered to the tapered surface 72 and to overcome pressures as might be created at the interface of the tapered surface 72 of the mandrel and the tubular member 210 when the self lubricating expansion mandrel 205 is acting to expand the tubular members 210.

[0075] FIG. 12 is a fragmentary cross-sectional view of one alternative embodiment of a self lubricating expansion mandrel having a grease delivery mechanism 90, and a groove 12 and a textured surface pattern 16 for receiving, retaining and providing grease to the tapered surface 92 of a self-lubricating expansion

mandrel 205 according to certain aspects of the invention. The combination of grease delivery mechanism 90, groove 12 at the leading edge 94 of the tapered surface 92 and the textured pattern 16 extending from the groove 12 toward the trailing edge 96 of the tapered surface of the self-lubricating expansion mandrel 205 facilitates movement of lubrication to the area on the tapered surface where the clearance between tubular and mandrel is minimum and expansion contact forces are found to be the greatest, thereby reducing friction and reducing seizing or galling.

[0076] The lubrication of the interface between an self-lubricating expansion mandrel and a tubular member during the radial expansion process will now be described. During the radial expansion process, a self-lubricating expansion mandrel radially expands a tubular member by moving in an axial direction relative to the tubular member. The interface between the outer surface of the tapered portion of the expansion cone and the inner surface of the tubular member includes a leading edge portion and a trailing edge portion.

[0077] During the radial expansion process, the leading edge portion is lubricated by the presence of lubrication provided on the surface of the expansion cone. However, because the radial clearance between the expansion cone and the tubular member in the trailing edge portion during the radial expansion process is typically extremely small, and the operating contact pressures between the tubular member and the self-lubricating expansion mandrel are extremely high, the quantity of lubricating fluid provided to the trailing edge portion is typically greatly reduced. In typical radial expansion operations, this reduction in lubrication in the trailing edge portion increases the forces required to radially expand the tubular member. However the retained solid lubrication continues to provide a small quantity of lubrication to keep the metal to metal interface separated and to reduce the friction.

[0078] An improved self-lubricating expansion mandrel may be useful for permitting a wellbore casing to be formed in a subterranean formation by placing a tubular member and a self-lubricating expansion mandrel in a new section of a wellbore, and then extruding the tubular member off of the self-lubricating expansion mandrel by pressurizing an interior portion of the tubular member. The apparatus and method further permits adjacent tubular members in the wellbore to be joined using an overlapping joint that prevents fluid and or gas passage. The apparatus and method further permits a new tubular member to be supported by an existing tubular member by expanding the new tubular member into engagement with the existing tubular member. The apparatus and method further minimizes the reduction in the hole size of the wellbore casing necessitated by the addition of new sections of wellbore casing.

[0079] An improved self-lubricating expansion mandrel may be useful for permitting a tie-back liner to be created by extruding a tubular member off of a mandrel by pressurizing an interior portion of the tubular member. In this manner, a tie-back liner is produced. The apparatus and method further permits adjacent tubular members in the wellbore to be joined using an overlapping joint that prevents fluid and/or gas passage. The apparatus and method further permits a new tubular member to be supported by an existing tubular member by expanding the new tubular member into engagement with the existing tubular member.

[0080] An apparatus and method for expanding a tubular member is also provided that includes an expandable tubular member, self-lubricating expansion mandrel and a shoe. In one embodiment, the interior portions of the apparatus is composed of materials that permit the interior portions to be removed using a conventional drilling apparatus. In this manner, in the event of a malfunction in a downhole region, the apparatus may be easily removed.

[0081] An improved self-lubricating expansion mandrel may be useful for permitting a tubular liner to be attached to an existing section of casing. The apparatus and method further have application to the joining of tubular members in general.

[0082] An improved self-lubricating expansion mandrel may be useful for permitting a wellhead to be formed including a number of expandable tubular members positioned in a concentric arrangement. The wellhead preferably includes an outer casing that supports a plurality of concentric casings using contact pressure between the inner casings and the outer casing.

[0083] An improved self-lubricating expansion mandrel may be useful for permitting for forming a mono-diameter well casing. The apparatus and method permit the creation of a well casing in a wellbore having a substantially constant internal diameter. In this manner, the operation of an oil or gas well is greatly simplified.

[0084] An improved self-lubricating expansion mandrel may be useful for isolating one or more subterranean zones from one or more other subterranean zones is also provided. The apparatus and method permits a producing zone to be isolated from a nonproducing zone using a combination of solid and slotted tubulars. In the production mode, the teachings of the present disclosure may be used in combination with conventional, well known, production completion equipment and methods using a series of packers, solid tubing, perforated tubing, and sliding sleeves, which will be inserted into the disclosed apparatus to permit the commingling and/or isolation of the subterranean zones from each other.

[0085] An improved self-lubricating expansion mandrel may be useful for forming a wellbore casing while the wellbore is drilled is also provided. In this manner, a wellbore casing can be formed simultaneous with the drilling out of a new section of the wellbore. Such an apparatus and method may be used in combination with one or more of the apparatus and methods disclosed in the present disclosure for forming wellbore casings using expandable tubulars. Alternatively, the method and apparatus can be used to create a pipeline or tunnel in a time efficient manner.

[0086] Although illustrative embodiments of the invention have been shown and described, a wide range of modification, changes and substitution is contemplated in the foregoing disclosure. In some instances, some features of the present invention may be employed without a corresponding use of the other features. Accordingly, it is appropriate that the appended claims be construed broadly and in a manner consistent with the scope of the invention.

Claims

1. A self-lubricating expansion mandrel for expanding a tubular member, comprising:
a housing including a tapered outer surface;
one or more grooves formed in the tapered outer surface; and
a grease supply chamber in the housing;
a conduit from the grease supply chamber to one or more of the grooves; and
means for forcing grease from the grease supply chamber through the conduit to one or more of the grooves.
2. The self-lubricating expansion mandrel of claim 1, wherein the one or more grooves comprise circumferential grooves.
3. The self-lubricating expansion mandrel of claim 1, wherein the grooves comprise axial grooves.
4. The self-lubricating expansion mandrel of claim 1, wherein the grooves comprise a pattern of grooves with both an axial and a circumferential component.
5. The self-lubricating expansion mandrel of claim 4, wherein the pattern of grooves comprises a textured surface.
6. A self-lubricating expansion device for expanding a tubular member, comprising:
a housing including a tapered outer surface;
one or more depressions formed in the tapered outer surface; and
a lubricant supply chamber in the housing;
a conduit from the lubricant supply chamber to one or more of the depressions; and
means for forcing lubricant from the lubricant supply chamber through the conduit to one or more of the depressions.
7. The self-lubricating expansion mandrel of claim 6, wherein the one or more depressions comprise circumferential grooves.

8. The self-lubricating expansion mandrel of claim 6, wherein the depressions comprise axial grooves.
9. The self-lubricating expansion mandrel of claim 6, wherein the depressions comprise a pattern of grooves with both an axial and a circumferential component.
10. The self-lubricating expansion mandrel of claim 9, wherein the pattern of grooves comprises a textured surface.
11. A self-lubricating expansion device for expanding a tubular member, wherein the interface between the expansion device and the tubular member, during the expansion process, includes a leading edge portion and a trailing edge portion, comprising:
 - a housing including a tapered outer surface;
 - one or more first depressions formed in the leading edge portion of the tapered outer surface; and
 - a lubricant supply chamber in the housing;
 - a conduit from the lubricant supply chamber to one or more of the first depressions;
 - means for forcing lubricant from the lubricant supply chamber through the conduit to one or more of the depressions;
 - one or more second depressions formed in the trailing edge portion of the tapered outer surface; and
 - a solid lubricant provided within one or more of the second depressions.
12. The self-lubricating expansion mandrel of claim 11, wherein one or more of the first and second depressions comprise circumferential grooves.
13. The self-lubricating expansion mandrel of claim 11, wherein one or more of the first and second depressions comprise axial grooves.
14. The self-lubricating expansion mandrel of claim 11, wherein one or more of the first and second depressions comprise a pattern of grooves with both an axial and a circumferential component.

15. The self-lubricating expansion mandrel of claim 14, wherein the pattern of grooves comprises a textured surface.

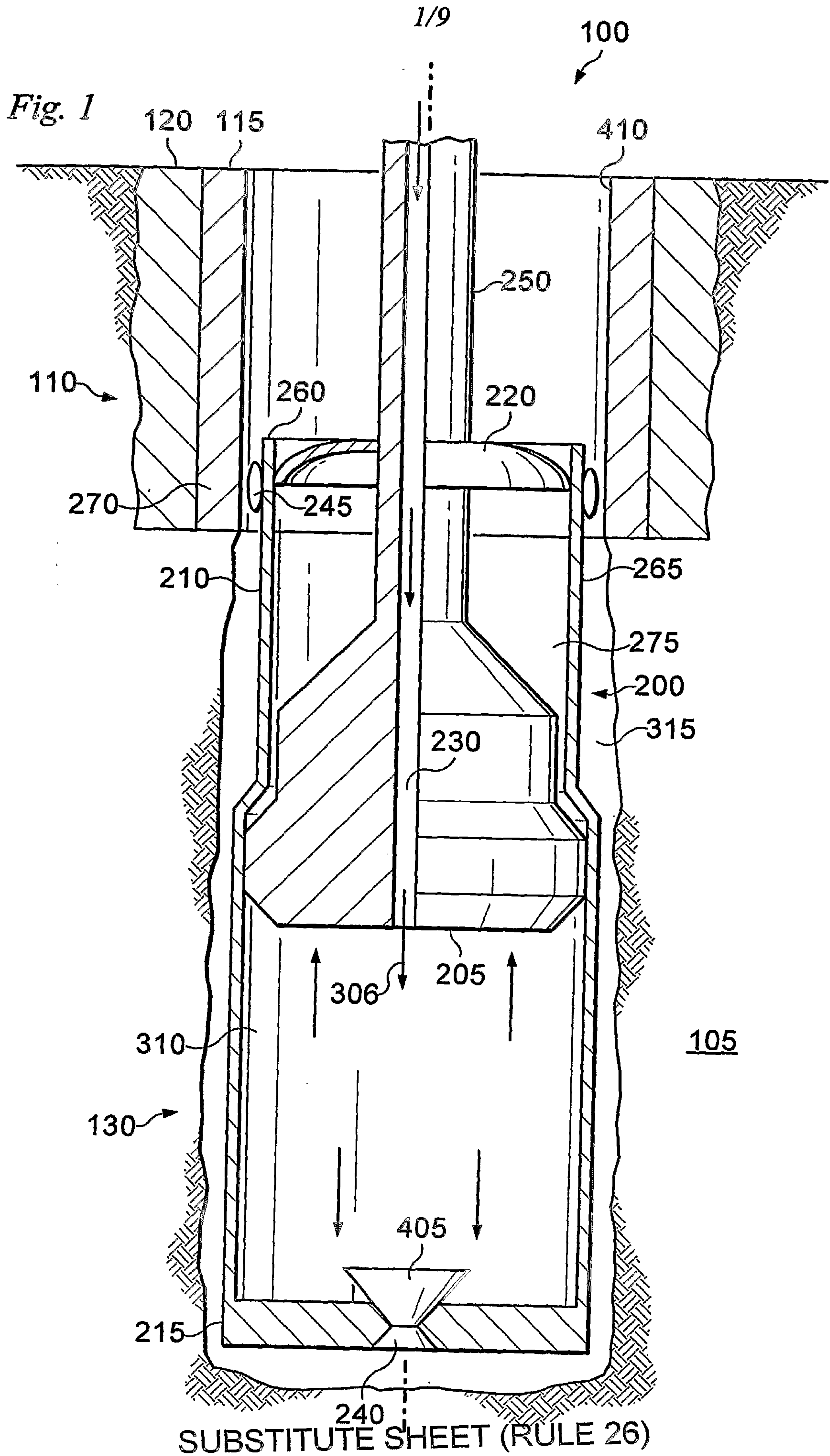

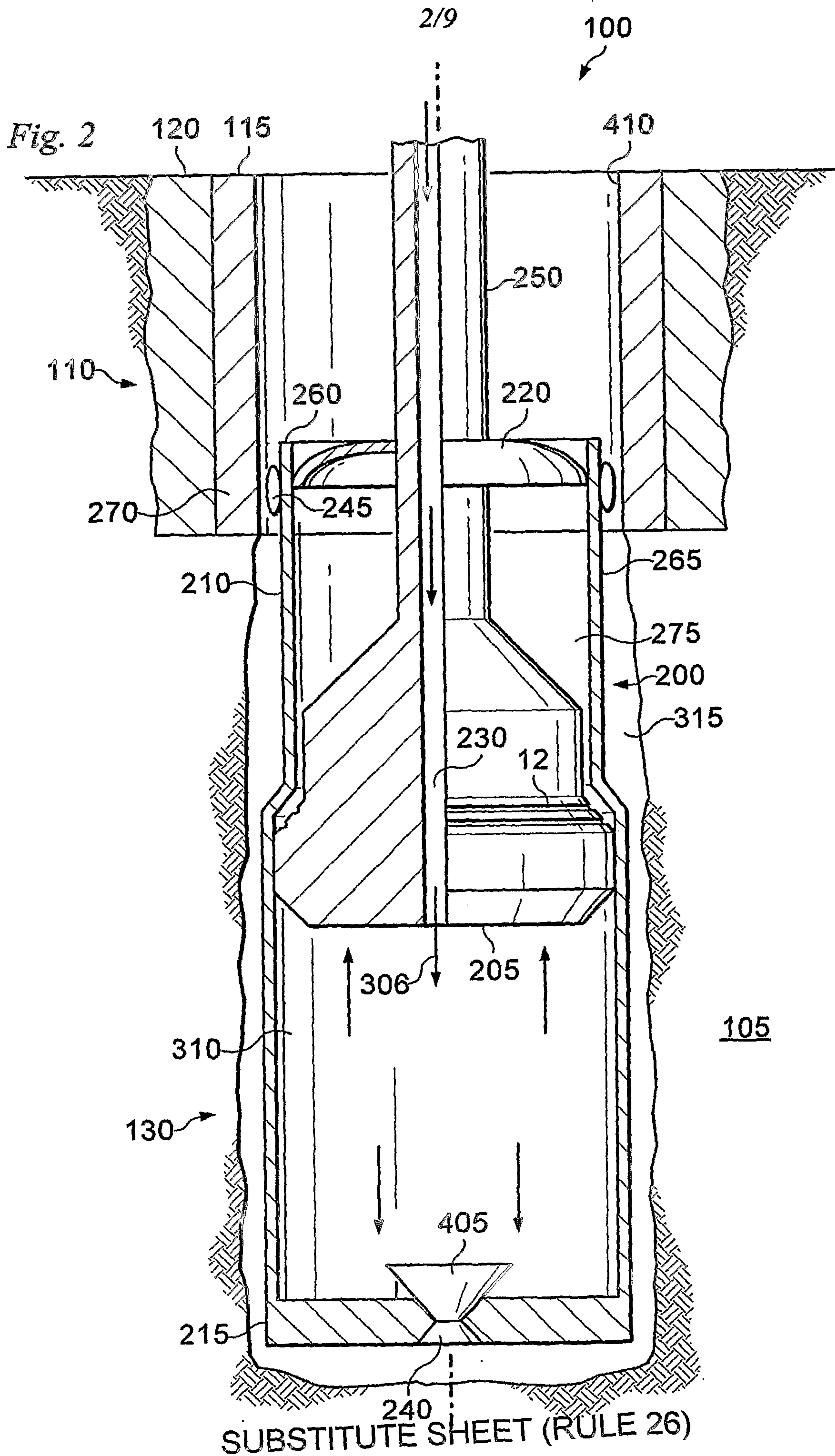

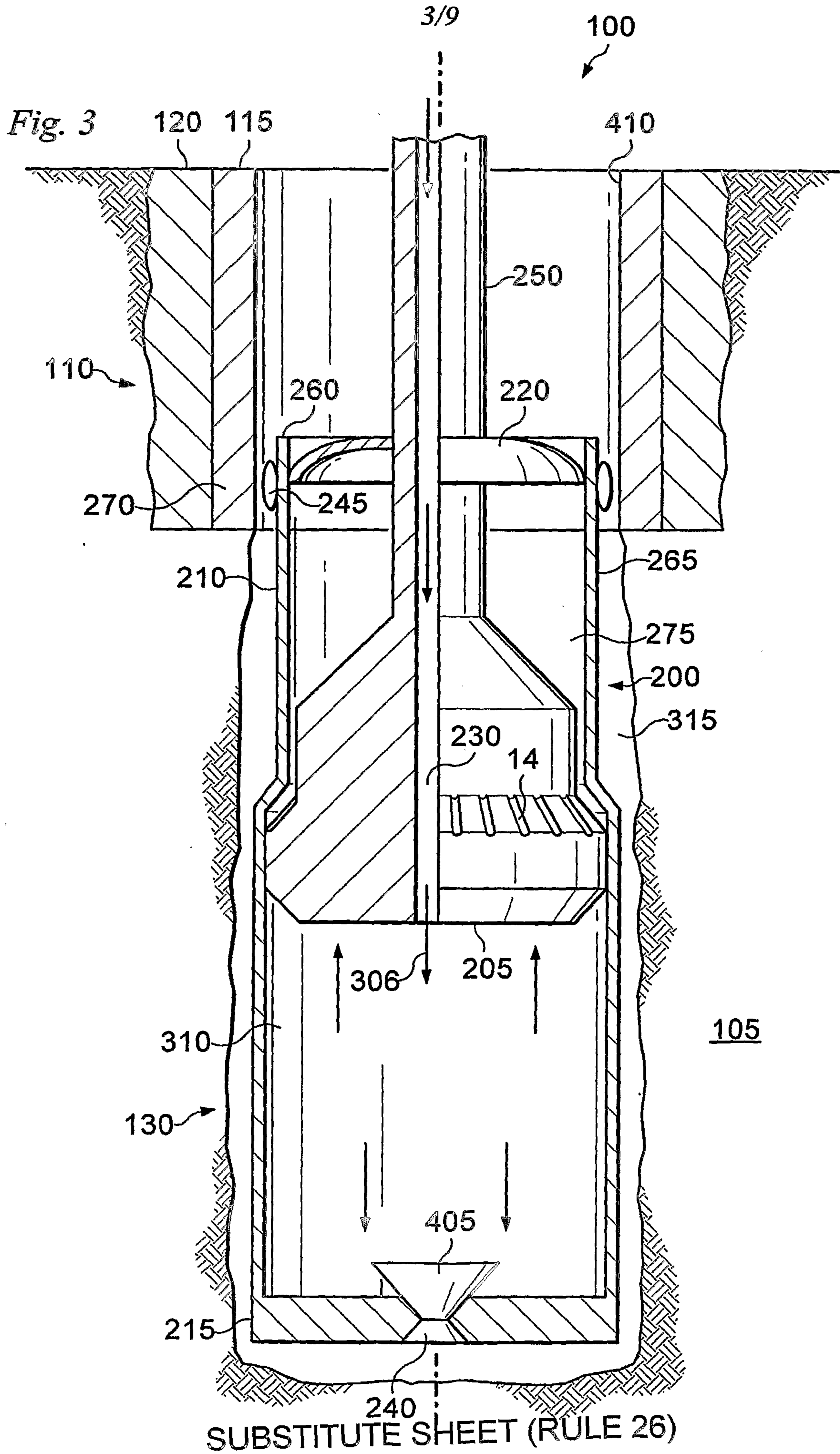

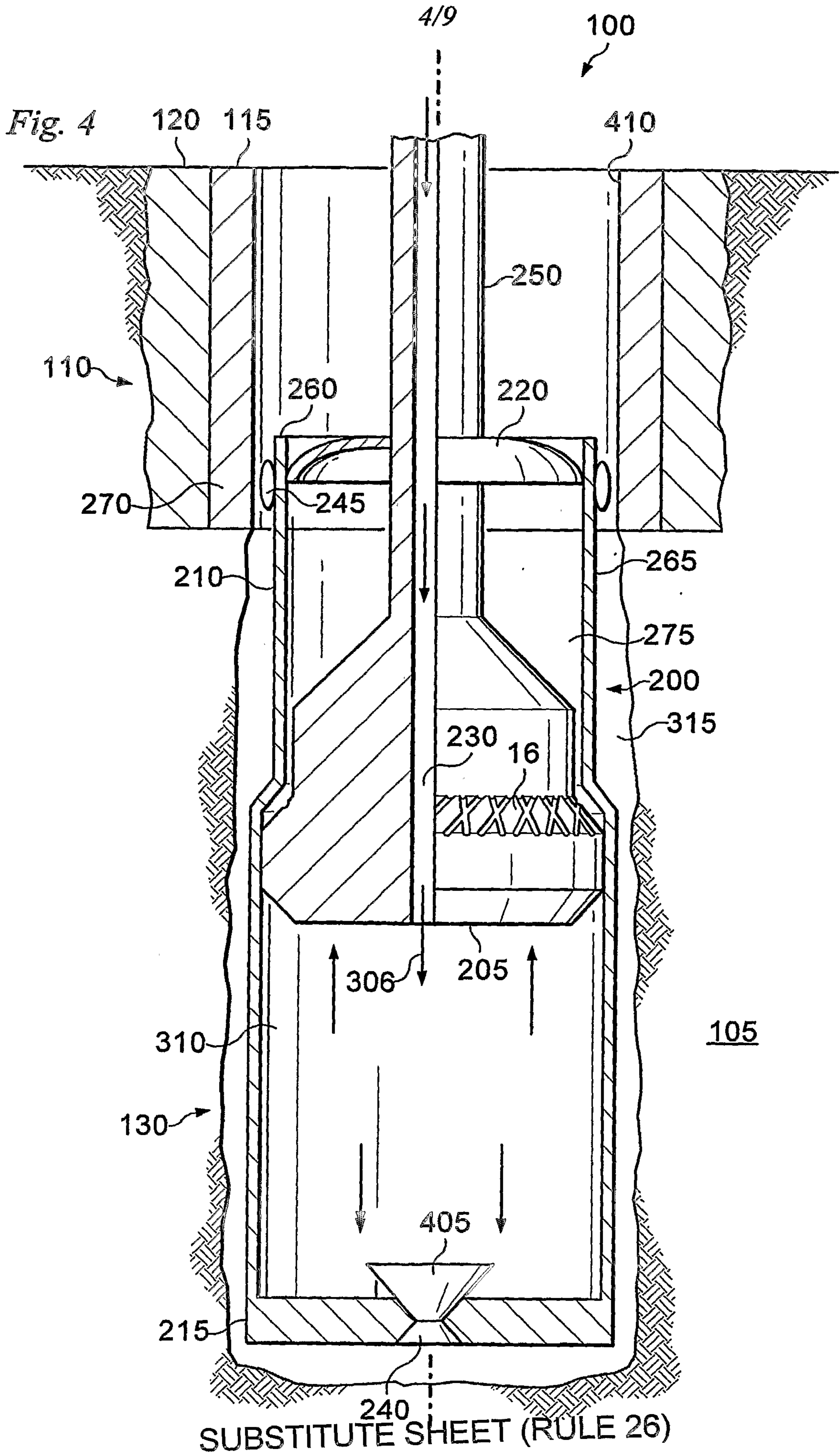
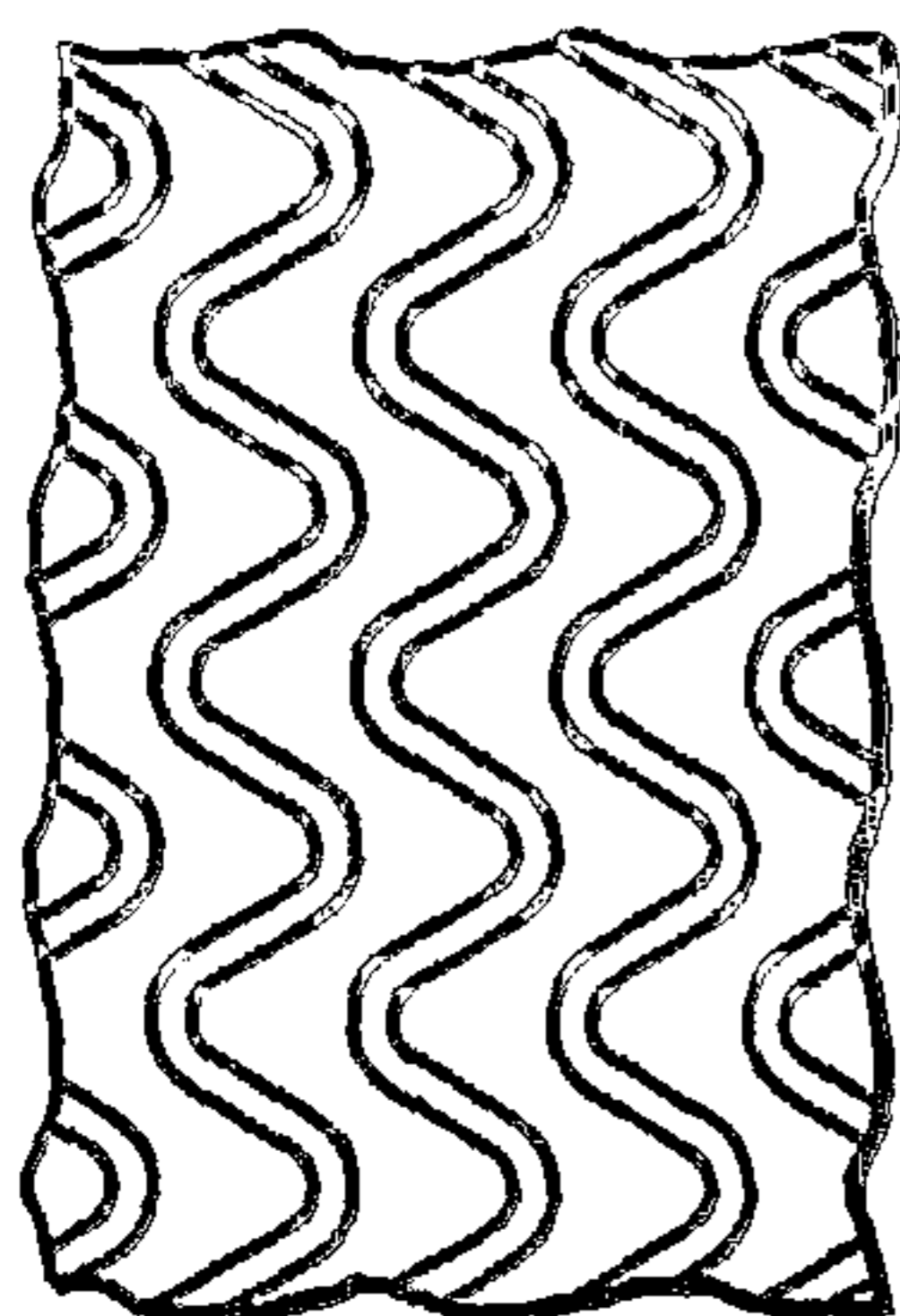
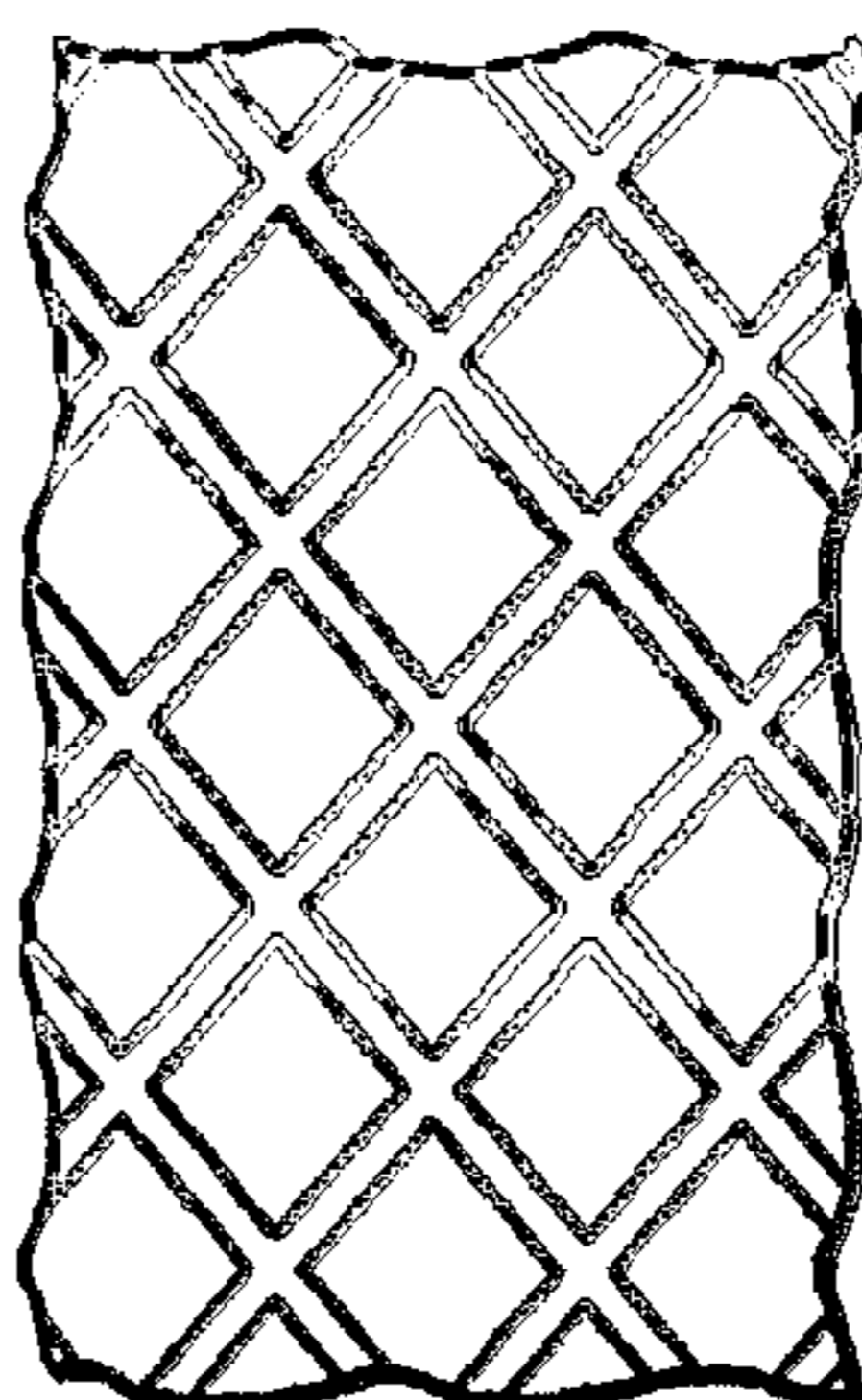

Fig. 5A



16A

Fig. 5B



16B

Fig. 5C

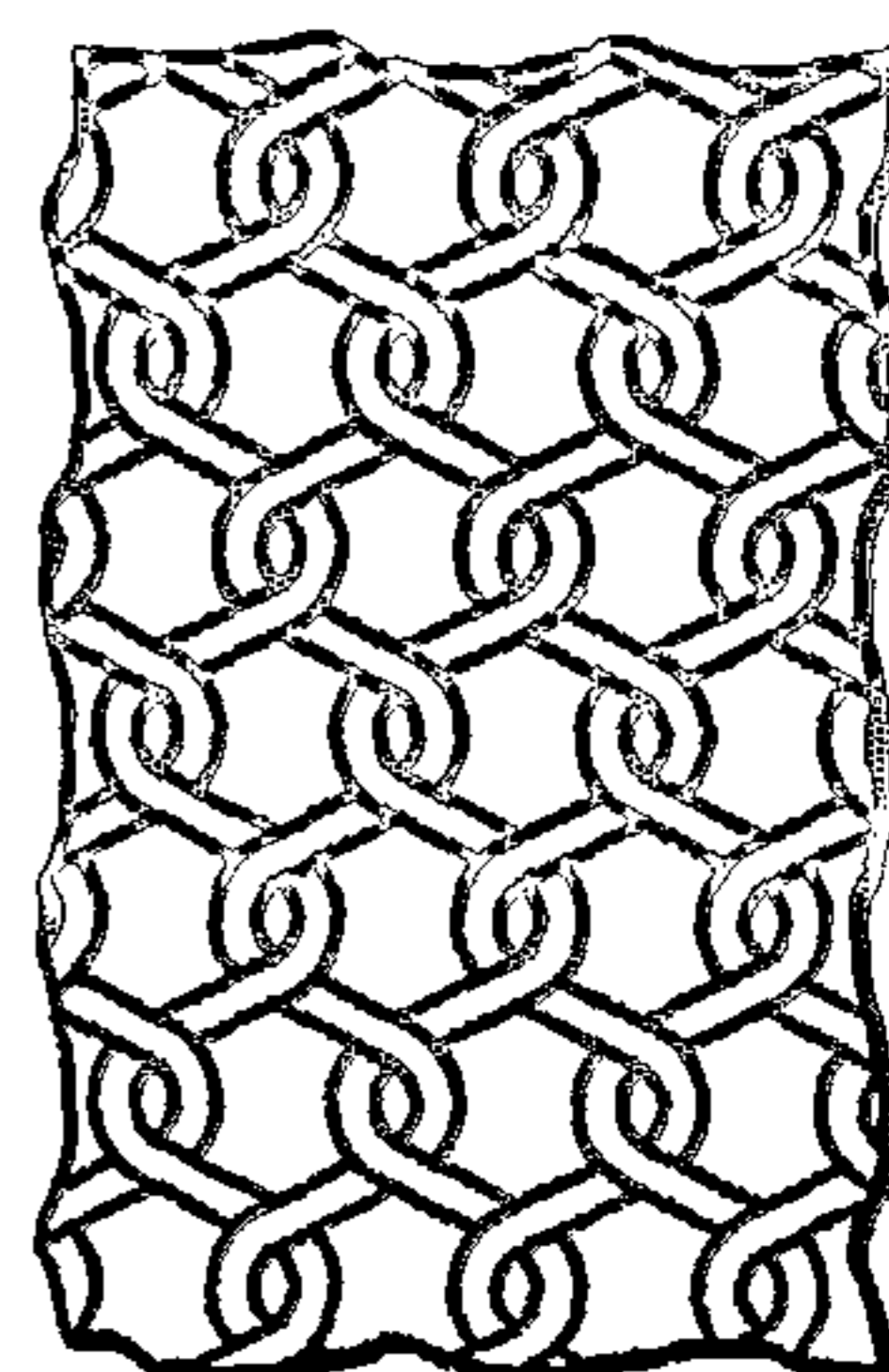

16C

Fig. 5D

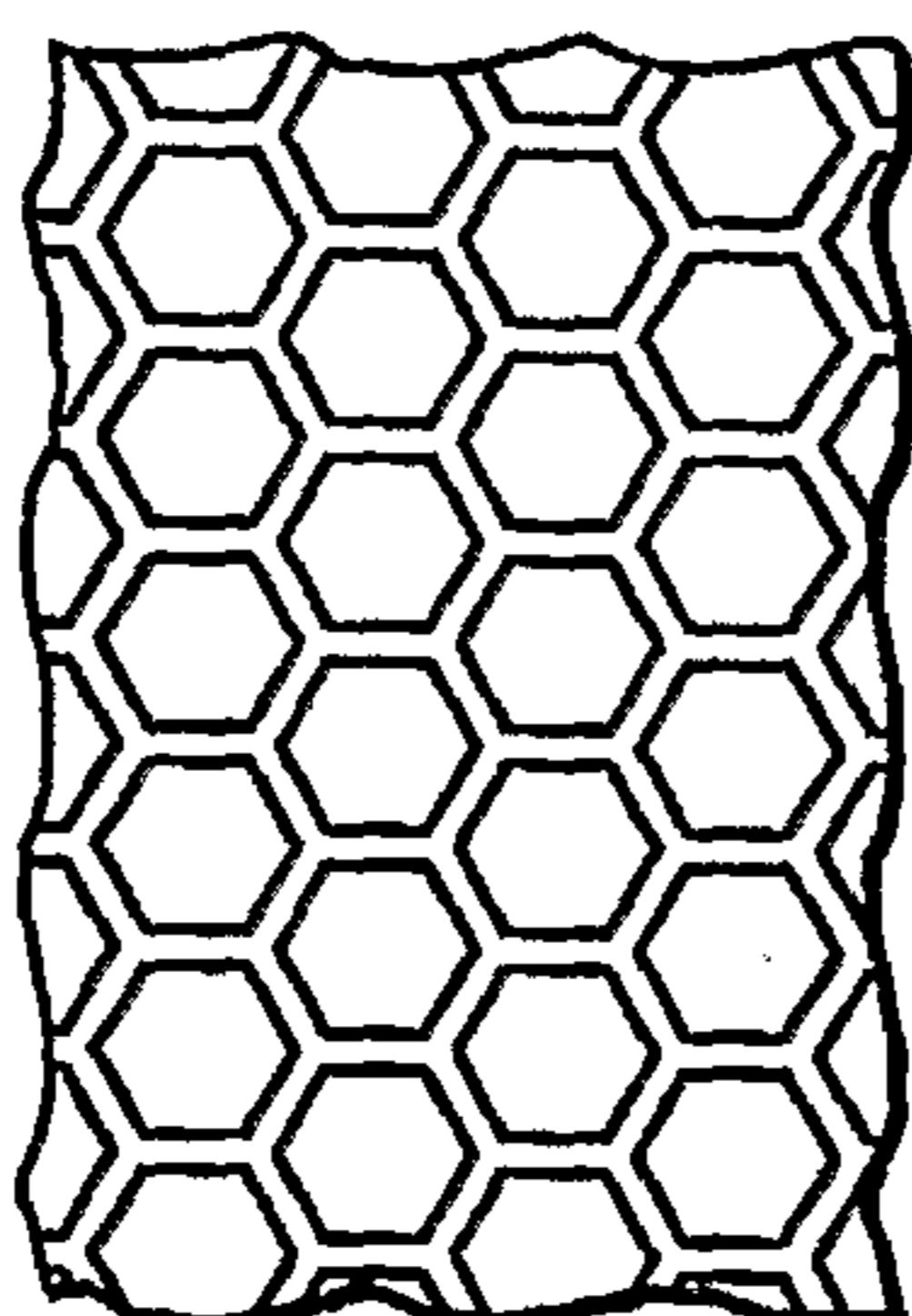

16D

Fig. 5E

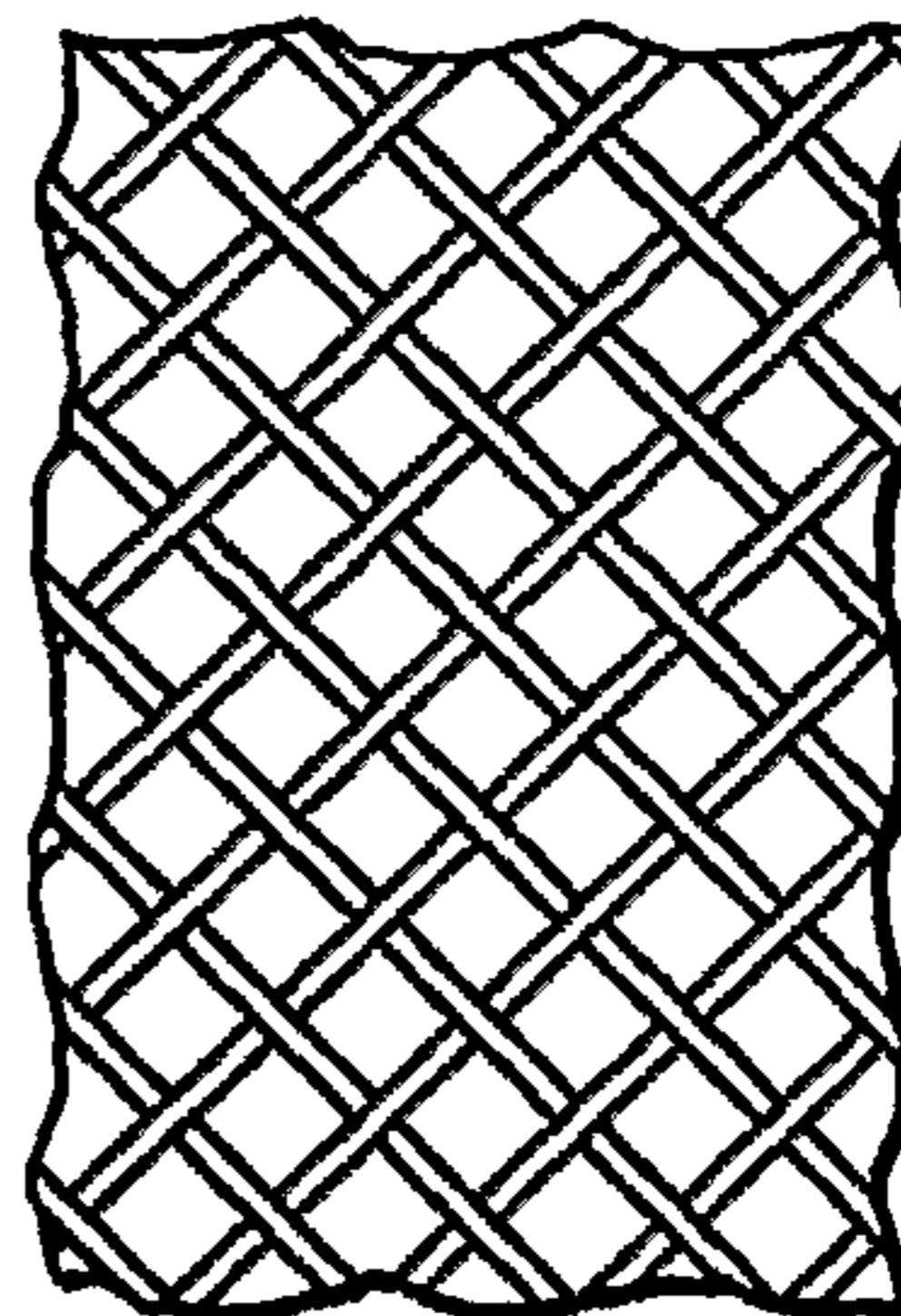

16E

Fig. 6A

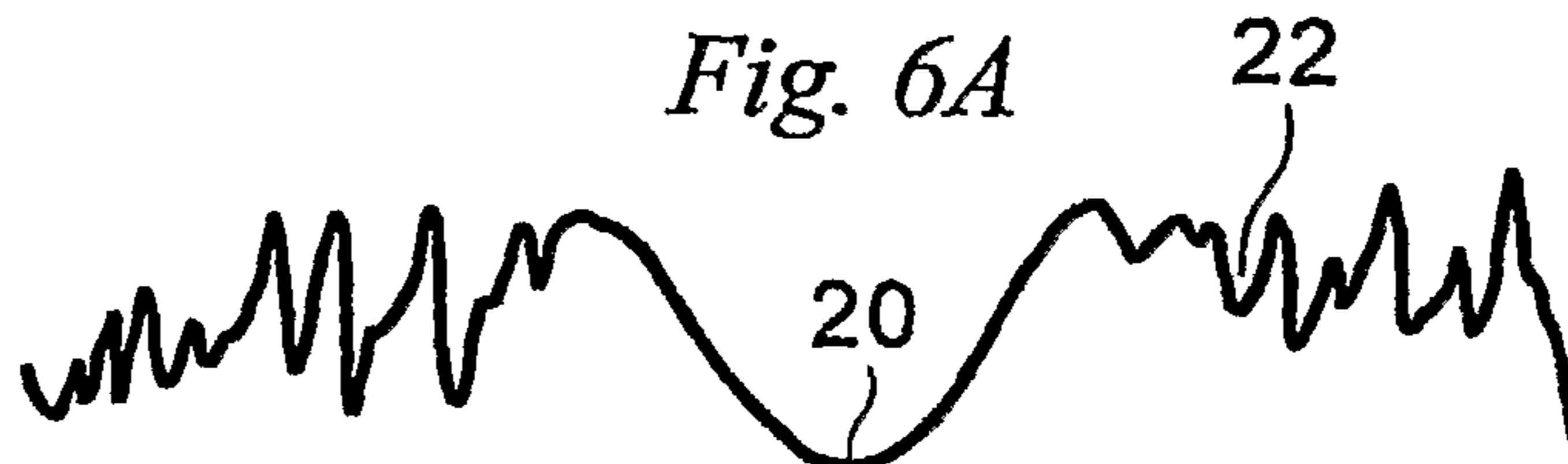
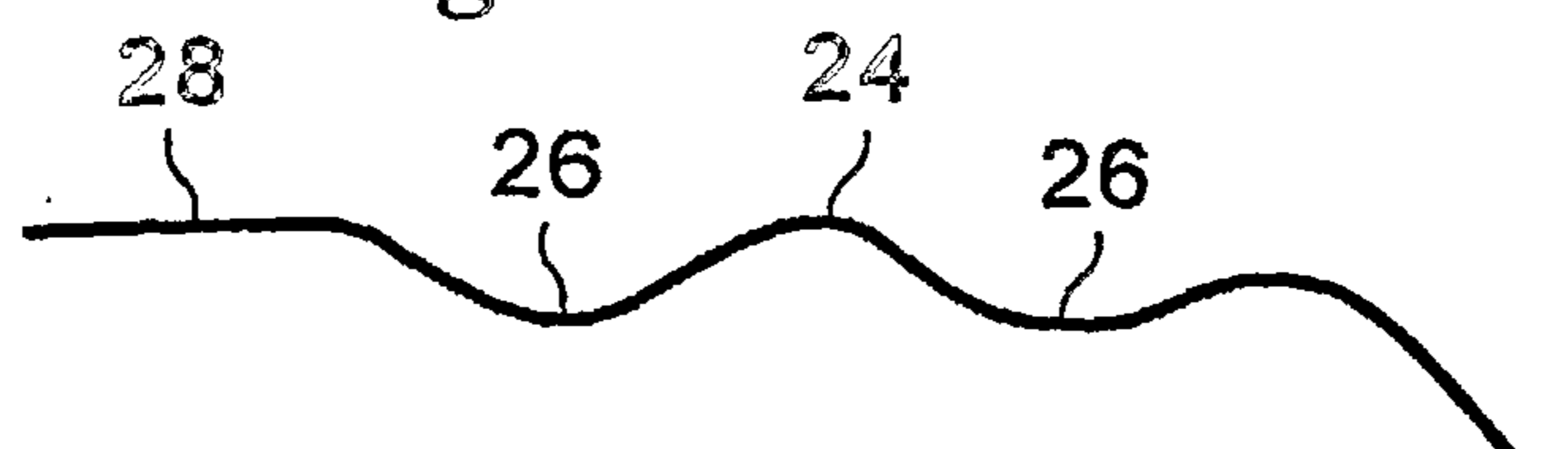

Fig. 6B



SUBSTITUTE SHEET (RULE 26)

Fig. 7A

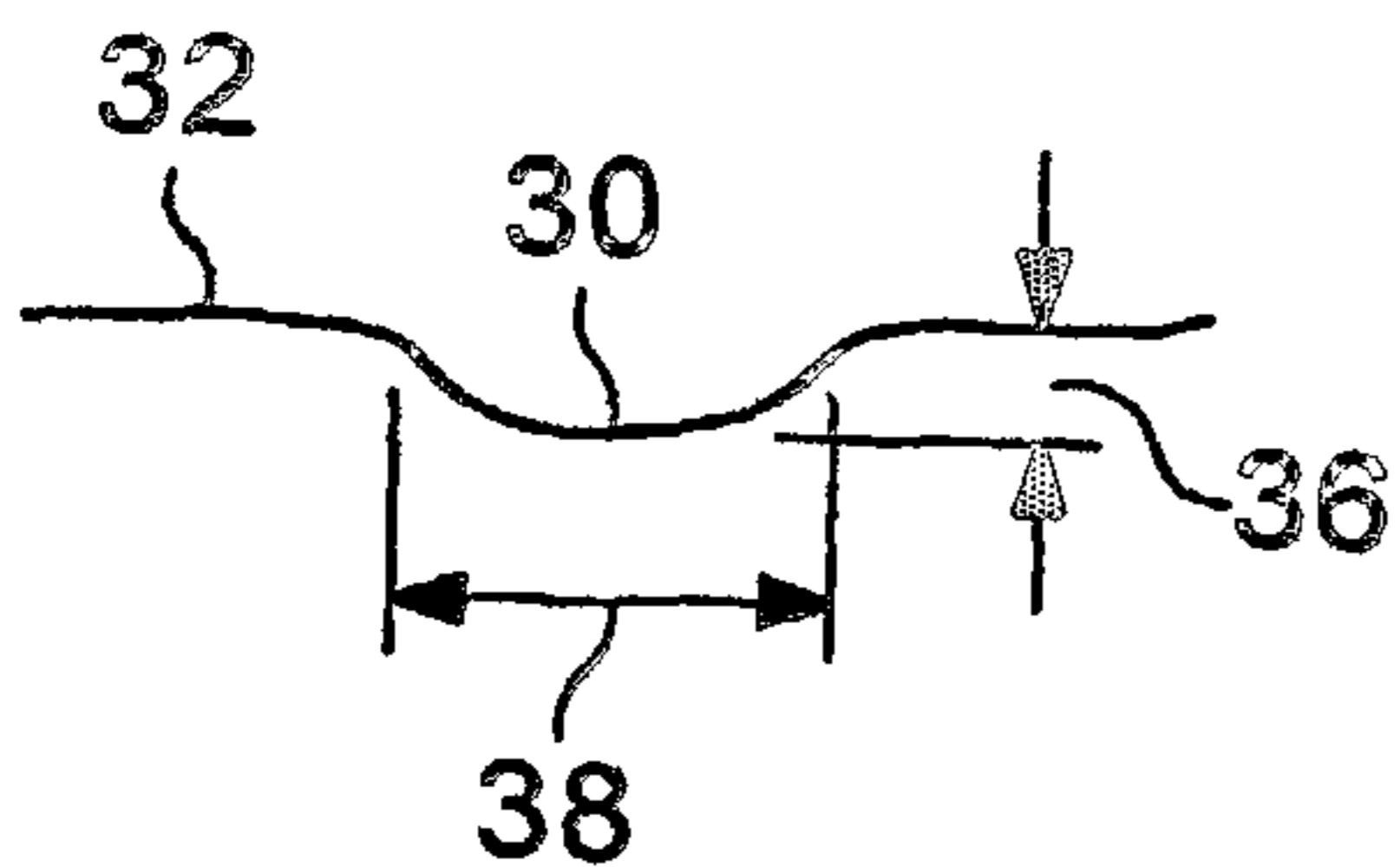

Fig. 7B

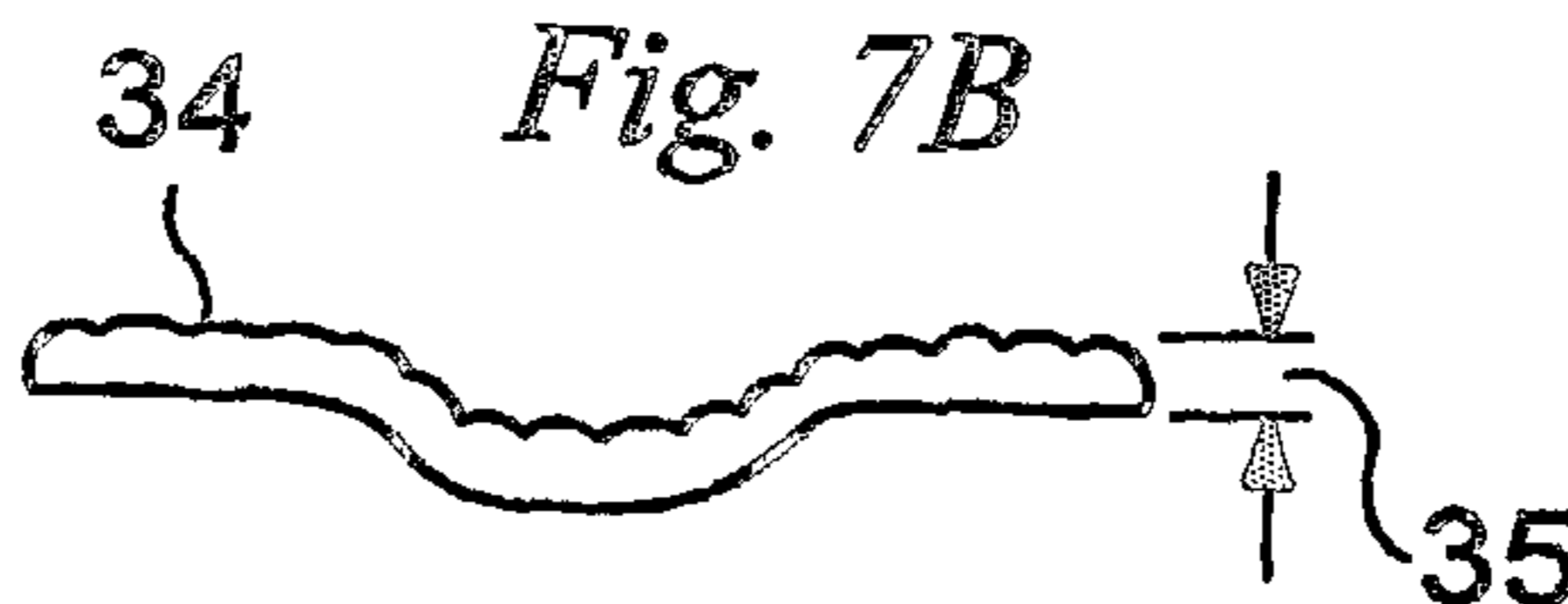

Fig. 7C

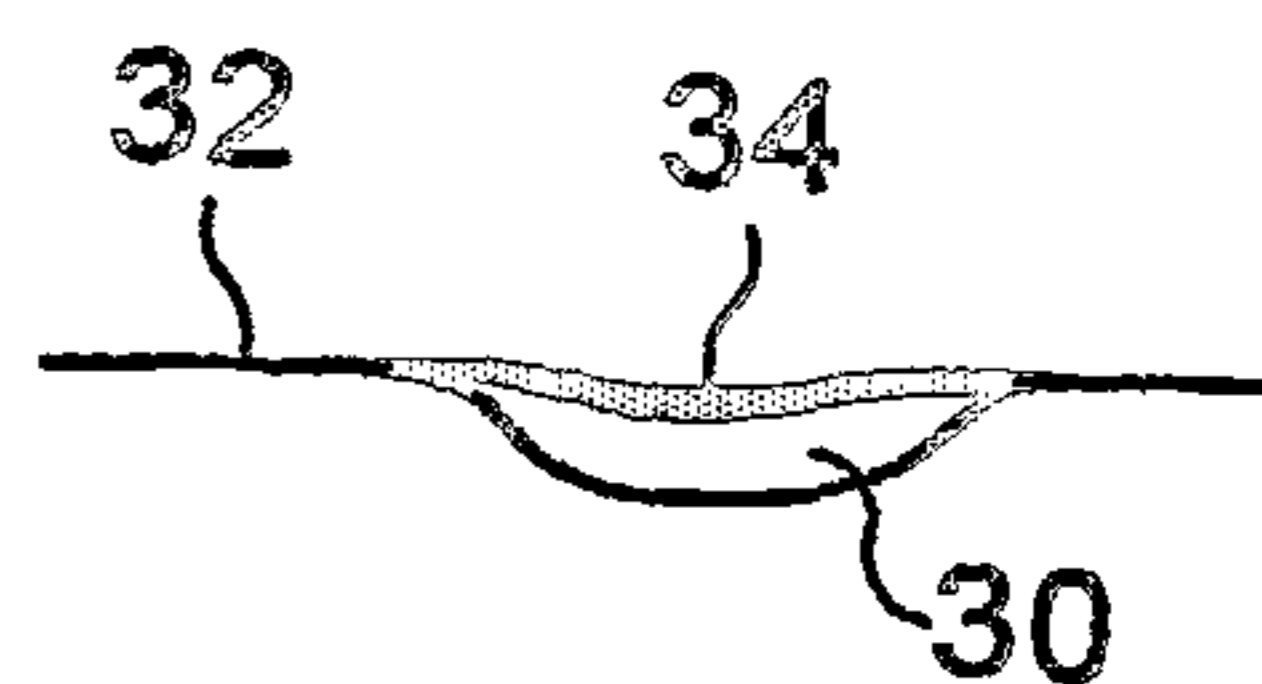

Fig. 8A

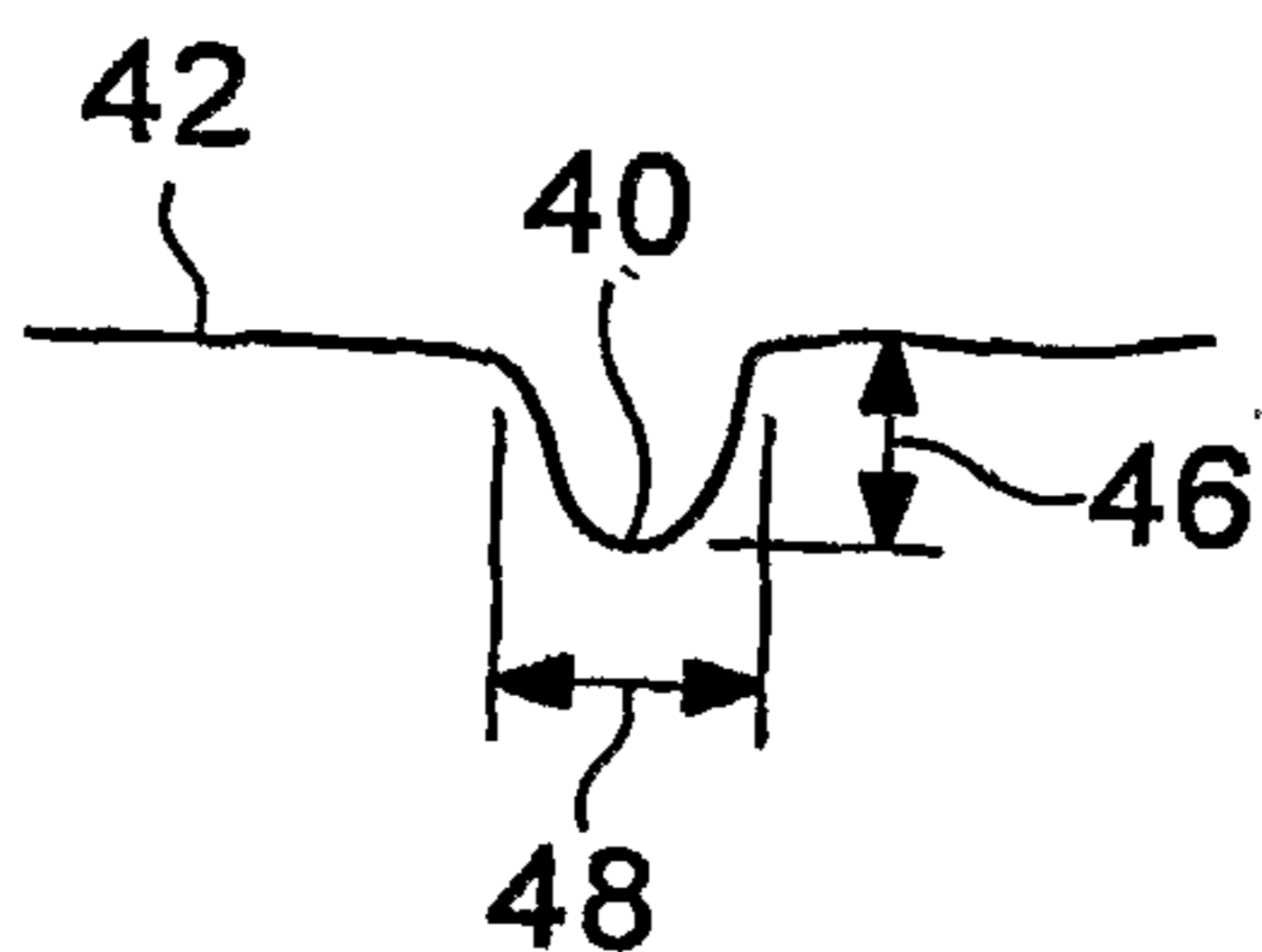

Fig. 8B

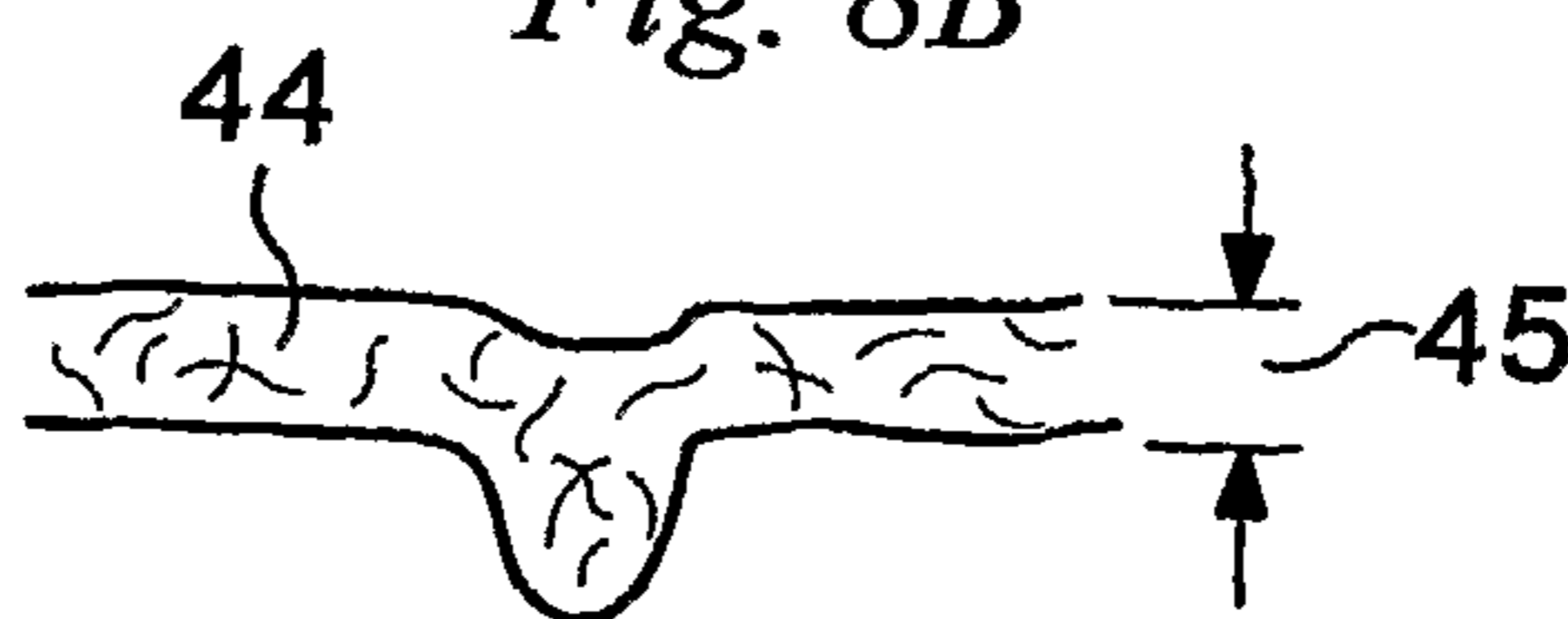

Fig. 8C

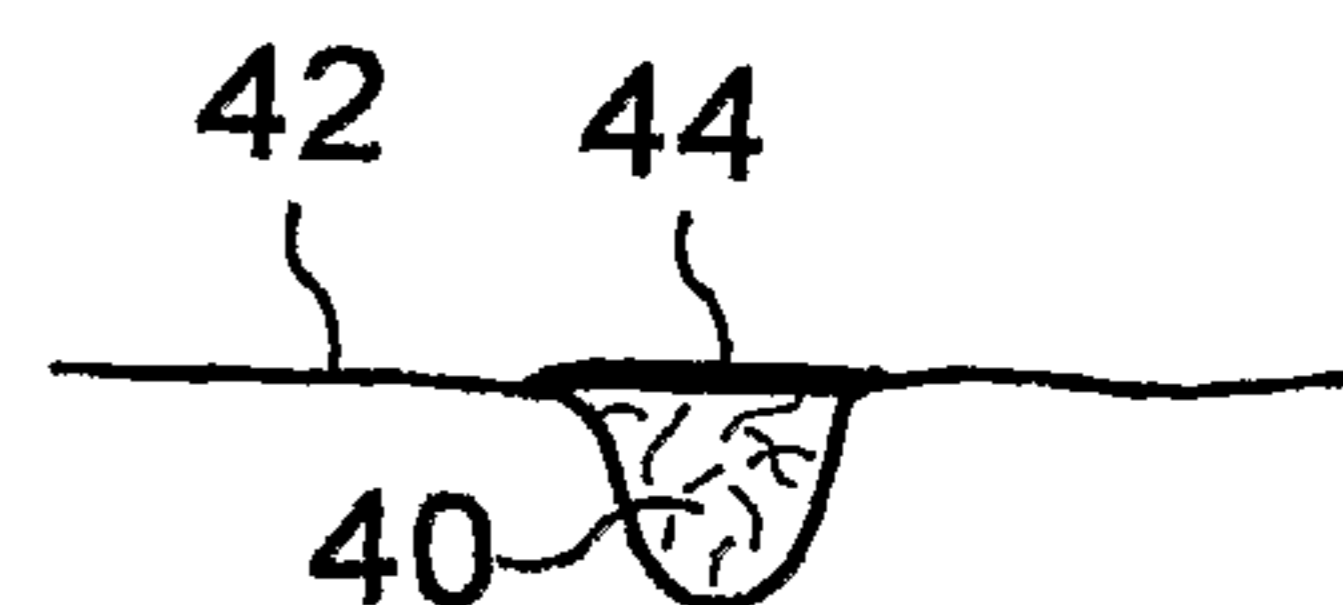

Fig. 9A

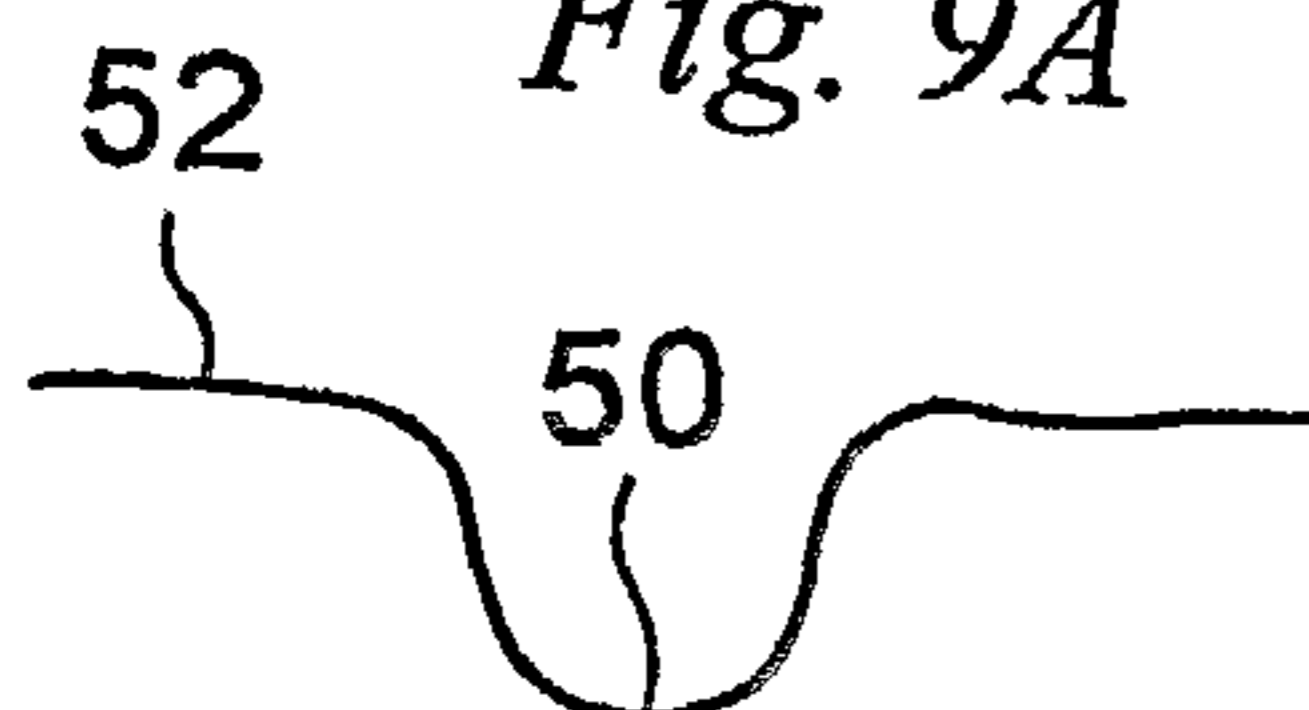

Fig. 9B

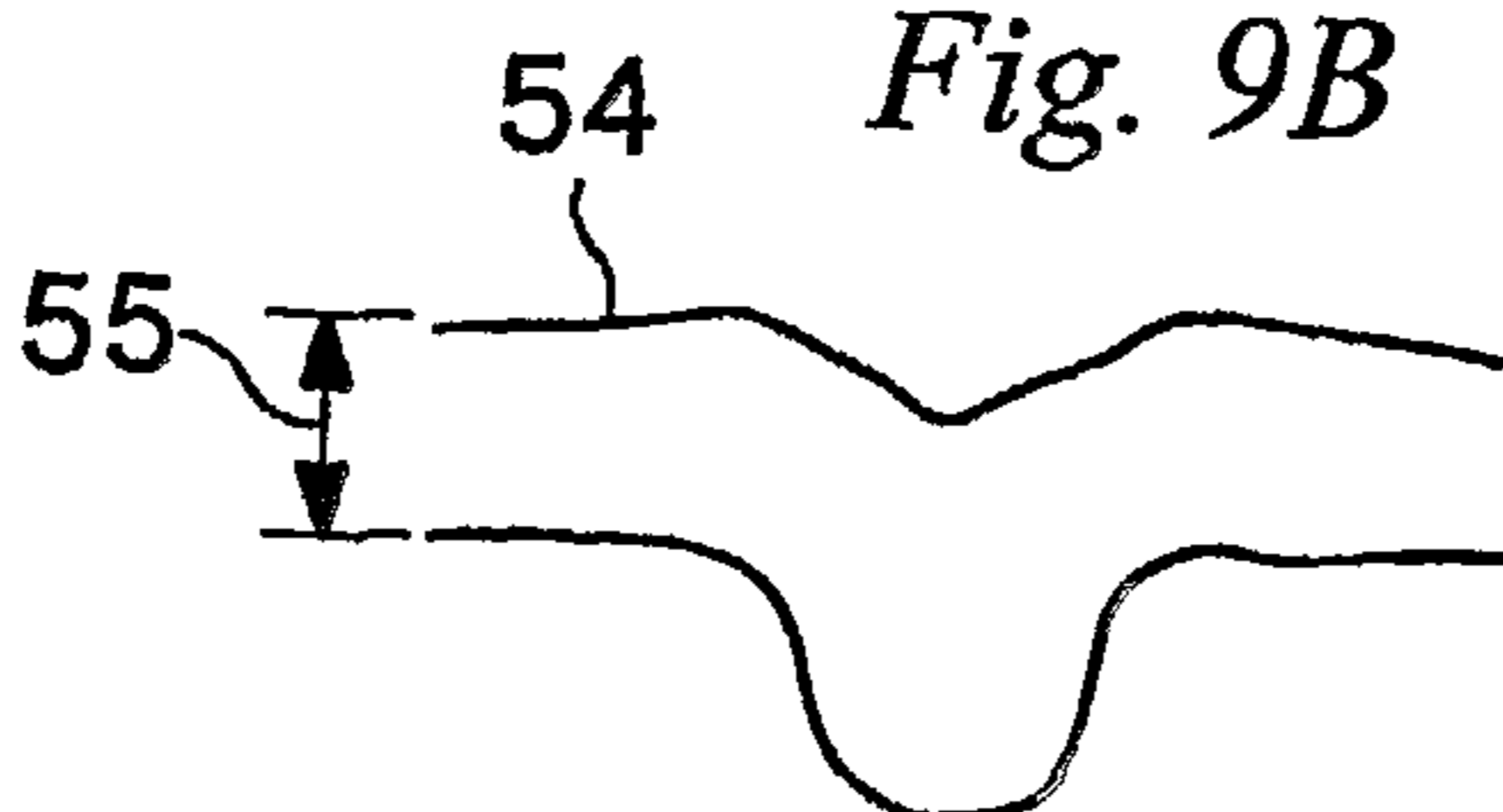
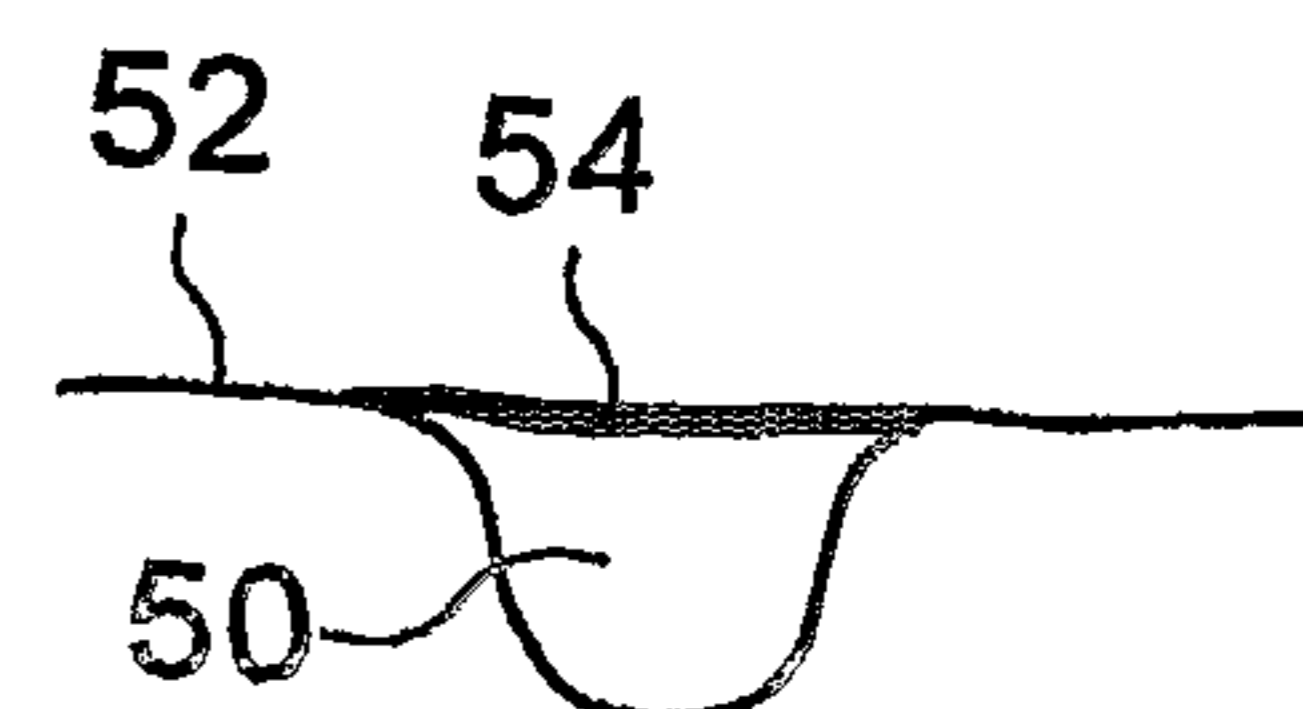
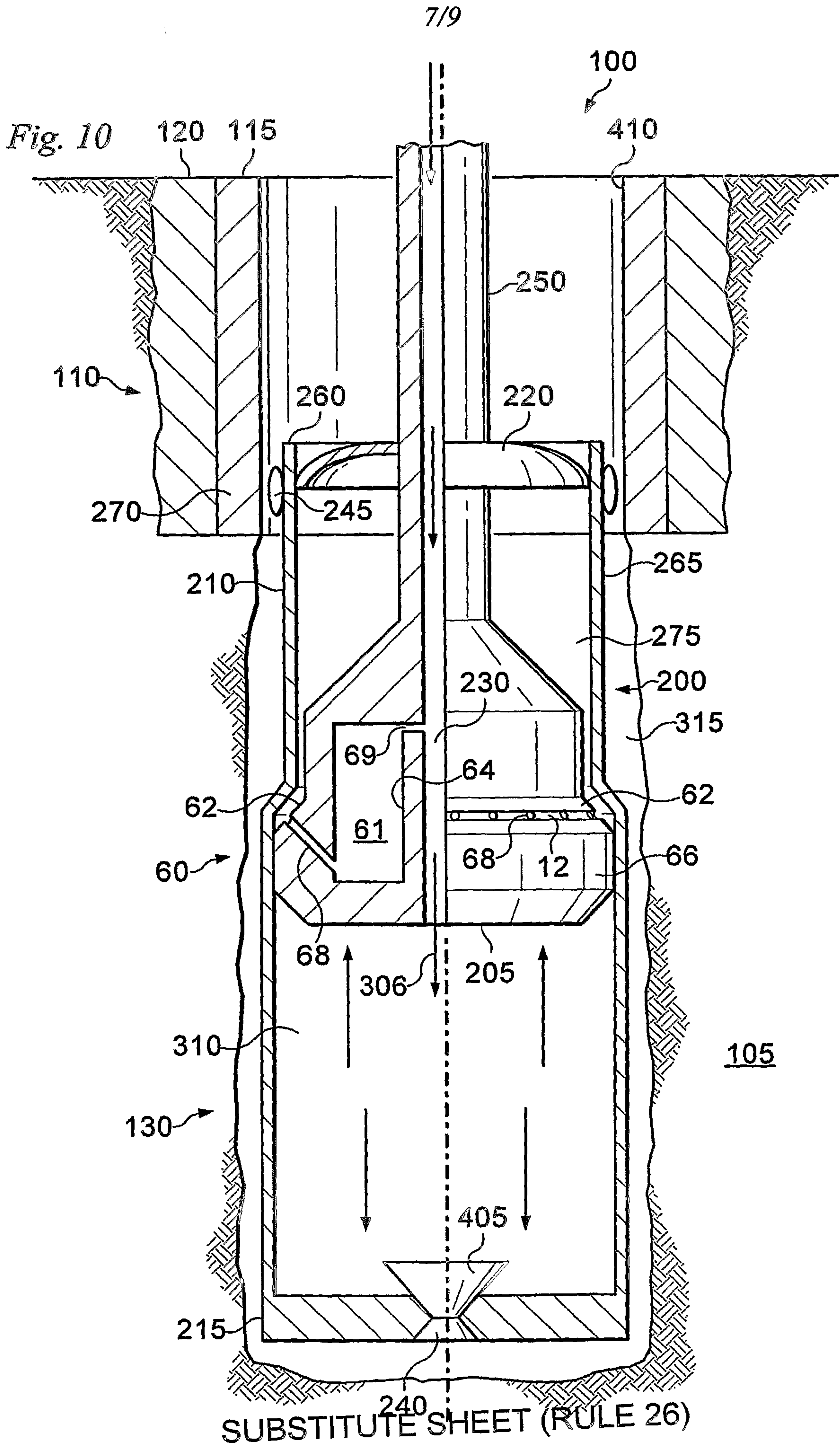
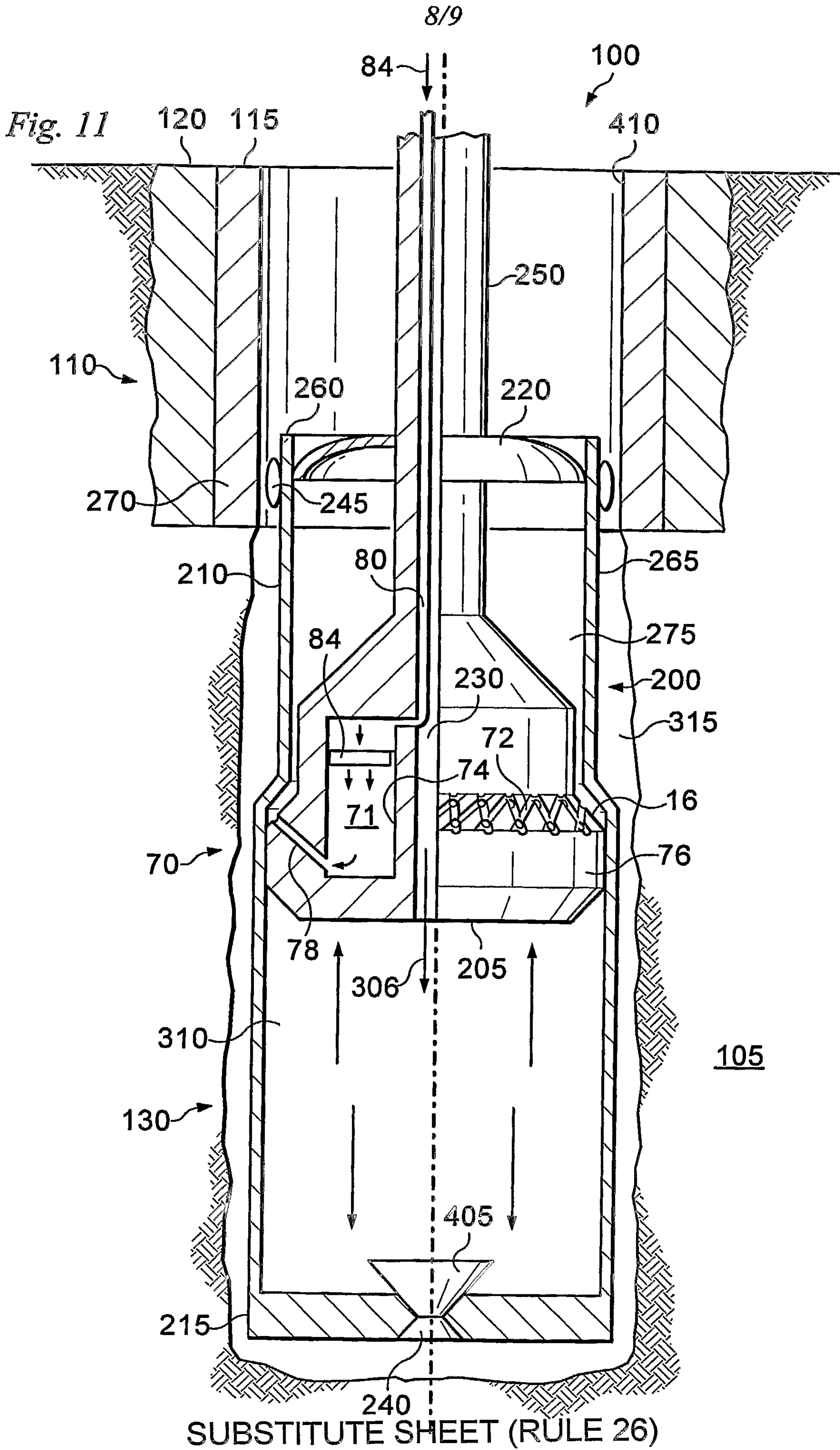

Fig. 9C







90

Fig. 12

