

S.P.M. Taster,

Tubing Mach.

No. 111,015.

Patented Jan. 17. 1871.

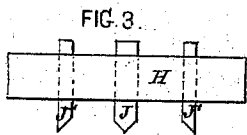
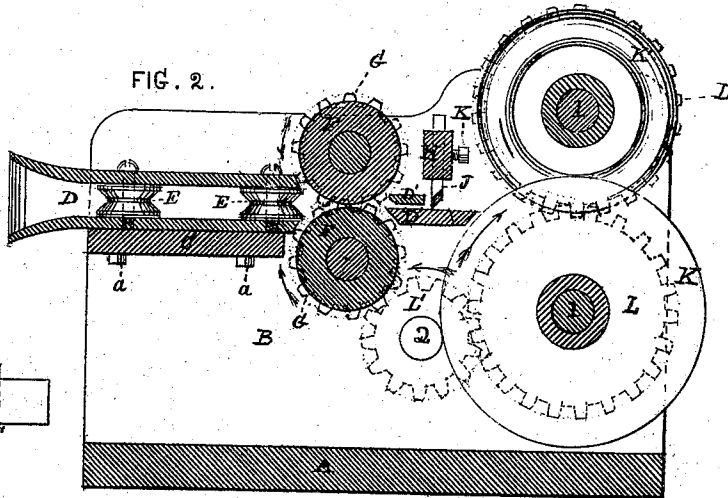
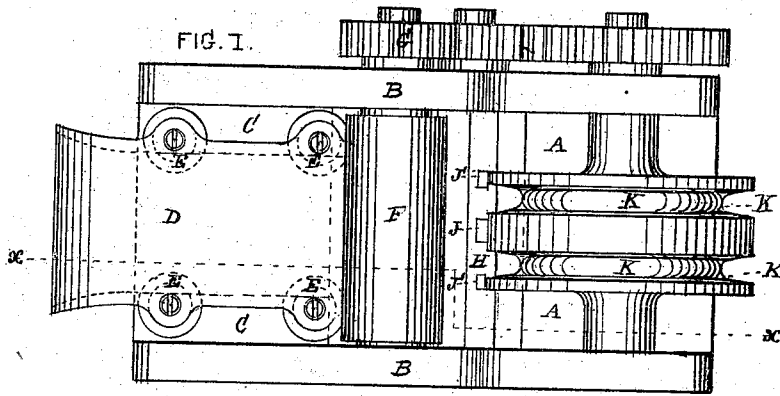

FIG. 4. FIG. 5.

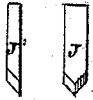

FIG. 8

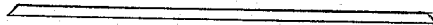

FIG. 9.

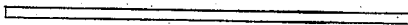
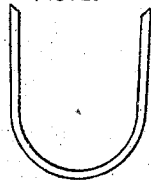

FIG. 10



WITNESSES.

Thomas J. Dudley
H. Nelson Henry

INVENTOR.

Stephen P. M. Taster
By his Attorney
Step. Untch

UNITED STATES PATENT OFFICE.

STEPHEN P. M. TASKER, OF PHILADELPHIA, PENNSYLVANIA.

IMPROVEMENT IN MACHINES FOR SLITTING, BEVELING, AND BENDING METAL-TUBE SKELPS.

Specification forming part of Letters Patent No. **111,015**, dated January 17, 1871.

To all whom it may concern:

Be it known that I, STEPHEN P. M. TASKER, of the city of Philadelphia, and State of Pennsylvania, have invented certain Improvements in Machines for Slitting, Beveling, and Bending Metal-Tube Skelps, of which the following is a specification.

The nature of my invention consists in the combination of stationary cutters of suitable form to slit the sheets and bevel the edges of the skelps at one operation with the feed-rolls and the first pair of bending-rolls. By this means the operation of making the tubes is greatly simplified and expedited.

To enable others skilled in the art to which my improvement appertains to make and use my invention, I will now give a detailed description thereof.

In the accompanying drawings, which make a part of this specification, Figure 1 is a plan view of the improved machine. Fig. 2 is a vertical section at the line *x x* of Fig. 1. Fig. 3 is a side view of the cutter-bar H and cutters J J' J' detached from the machine. Fig. 4 is a back view of the middle cutter, J, detached from the cutter-bar H. Fig. 5 is a like view of one of the outside cutters, J'. Fig. 6 is an end view of a flat skelp for forming a lap-joint tube. Fig. 7 is a like view of a butt-joint skelp. Fig. 8 represents an end view of a skelp when passed through the rolls K K'.

Like letters in all the figures indicate the same parts.

A is the bed-plate of the machine, and B B the housings connected therewith. To the latter the several parts of the machine are connected. I confine by means of bolts *a* on the horizontal plate C, connected at each end of the housings B B, a mouth, D, which is provided with grooved carrying-wheels E E E E, that convey the sheets to the feed-rolls F F. These rolls are geared together by means of wheels G G, and pass the sheet to the bending-rolls. As the sheet passes the feed-rolls it comes in contact with the vertical cutters J J' J' in the cross-bar H. The said cutters slit the sheets into the right widths for the skelps, and bevel the edges of the latter at the same time. The cutters are situated in slots of the bar H, and are confined in their adjusted position by

means of set-screws *k*. The middle cutter, J, has a double angle, *b b*, as seen in Figs. 3 and 4, so as to bevel the contiguous edges of both skelps; but the outer cutters, J' J', have each a single angular cutting-edge, as shown in Figs. 3 and 5.

To prevent the buckling of the sheets of metal as they pass from the feed-rolls to the bending-rolls, I confine between the housings B B guide-plates D' D', the upper plate being slotted for the passage of the cutters. After the skelps pass the cutters they are caught by the double bending roll K K', situated on the shafts 1 1', which bend them into the form represented in Fig. 8.

The feed-rolls F F and shafts 1 1', on which the bending-rolls K K' are situated, are geared together by means of the wheels L L on the said shafts 1 1' and wheel L' on the short shaft 2, the latter gearing into the wheel G of the lower roll, F, as seen in Fig. 2. Power being applied to either shaft of the series, the feed and bending rolls are caused to revolve in the direction of the arrows, whereby the sheets are slit into skelps, and the latter beveled on their edges and bent into the form represented in Fig. 8 as they pass through the machine.

Other rolls may be added as may be desired to give the finishing bend to the skelps.

What I claim as my invention, and desire to secure by Letters Patent, is—

1. The adjustable beveled cutters J J' J', in combination with the guide-plates D' D' and feed-rolls F F or their equivalent, substantially as described.

2. The combination and arrangement of the feed-rolls F F, guides D' D', beveled cutters J J' J', and bending-rolls K K', for slitting, beveling, and bending the skelps at one operation, substantially as described.

In testimony that the above is my invention I have hereunto set my hand and affixed my seal this 30th day of August, 1870.

STEPHEN P. M. TASKER. [L. S.]

Witnesses:

THOMAS J. BEWLEY,
STEPHEN USTICK.